



# TS7900 series

## 3-Terminal Fixed Negative Output Voltage Regulator

TO-220



ITO-220



Pin assignment:  
 1. Ground  
 2. Input  
 3. Output  
 (Heatsink surface connected to Pin 2)

**Voltage Range - 5V to - 24V**  
**Output Current up to 1A**

### General Description

The TS7900 series of fixed output negative voltage regulators are intended as complements to the popular TS7800 series device. These negative regulators are available in the same seven-voltage options as the TS7800 devices. In addition, one extra voltage option commonly employed in MECL systems is also available in the negative TS7900 Series. Available in fixed output voltage options from -5.0 to -24 volts, these regulators employ current limiting, thermal shutdown, and safe-area compensation--making them remarkably rugged under most operating conditions. With adequate heatsinking they can deliver output currents in excess of 1 ampere. This series is offered in 3-pin TO-220, ITO-220 package.

### Features

- ✧ Output current up to 1A
- ✧ No external components required
- ✧ Internal thermal overload protection
- ✧ Internal short-circuit current limiting
- ✧ Output transistor safe-area compensation
- ✧ Output voltage offered in 4% tolerance

### Standard Application

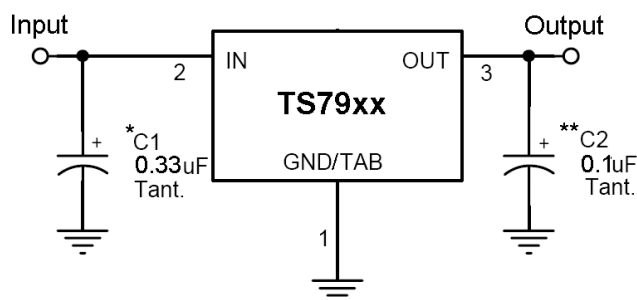

A common ground is required between the input and the output voltages. The input voltage must remain typically 2.0V above the output voltage even during the low point on the Input ripple voltage.

XX = these two digits of the type number indicate voltage.

\* = C<sub>in</sub> is required if regulator is located an appreciable distance from power supply filter.

\*\* = C<sub>o</sub> is not needed for stability; however, it does improve transient response.

### Ordering Information

Part No.	Operating Temp.	Package
TS79xxCZ	0 ~ +125°C	TO-220
TS79xxCI		ITO-220

Note: Where xx denotes voltage option.

### Absolute Maximum Rating

Input Voltage	V <sub>in</sub> *	- 35	V
Input Voltage	V <sub>in</sub> **	- 40	V
Power Dissipation	TO-220	Without heatsink	2
	TO-220	P <sub>t</sub> ***	15
	ITO-220	Without heatsink	10
Operating Junction Temperature Range	T <sub>J</sub>	0 ~ +125	°C
Storage Temperature Range	T <sub>STG</sub>	-65 ~ +150	°C

Note : \* TS7905 to TS7918

\*\* TS7924

\*\*\* Follow the derating curve



### TS7905 Electrical Characteristics

( $V_{in} = -10V$ ,  $I_{out} = 500mA$ ,  $0^{\circ}C \leq T_j \leq 125^{\circ}C$ ,  $C_{in} = 0.33\mu F$ ,  $C_{out} = 0.1\mu F$ ; unless otherwise specified.)

Parameter	Symbol	Test Conditions	Min	Typ	Max	Unit	
Output voltage	Vout	$T_j = 25^{\circ}C$	-4.80	-5	-5.20	V	
		$-7.5V \leq V_{in} \leq -20V$ , $10mA \leq I_{out} \leq 1A$ , $PD \leq 15W$	-4.75	-5	-5.25		
Line Regulation	REGline	$T_j = 25^{\circ}C$	$-7.5V \leq V_{in} \leq -25V$	--	3	100	mV
			$-8V \leq V_{in} \leq -12V$	--	1	50	
Load Regulation	REGload	$T_j = 25^{\circ}C$	$10mA \leq I_{out} \leq 1A$	--	15	100	
			$250mA \leq I_{out} \leq 750mA$	--	5	50	
Quiescent Current	Iq	$I_{out} = 0$ , $T_j = 25^{\circ}C$	--	4	8	mA	
Quiescent Current Change	$\Delta Iq$	$-7.5V \leq V_{in} \leq -25V$	--	--	1.3		
		$10mA \leq I_{out} \leq 1A$	--	--	0.5		
Output Noise Voltage	Vn	$10Hz \leq f \leq 100KHz$ , $T_j = 25^{\circ}C$	--	40	--	$\mu V$	
Ripple Rejection Ratio	RR	$f = 120Hz$ , $-8V \leq V_{in} \leq -18V$	62	74	--	dB	
Voltage Drop	Vdrop	$I_{out} = 1.0A$ , $T_j = 25^{\circ}C$	--	2	--	V	
Peak Output Current	I <sub>o peak</sub>	$T_j = 25^{\circ}C$	--	2.1	--	A	
Temperature Coefficient of Output Voltage	$\Delta V_{out}/\Delta T_j$	$I_{out} = 10mA$ , $0^{\circ}C \leq T_j \leq 125^{\circ}C$	--	-1	--	mV/ $^{\circ}C$	

### TS7906 Electrical Characteristics

( $V_{in} = -11V$ ,  $I_{out} = 500mA$ ,  $0^{\circ}C \leq T_j \leq 125^{\circ}C$ ,  $C_{in} = 0.33\mu F$ ,  $C_{out} = 0.1\mu F$ ; unless otherwise specified.)

Parameter	Symbol	Test Conditions	Min	Typ	Max	Unit	
Output Voltage	Vout	$T_j = 25^{\circ}C$	-5.75	-6	-6.25	V	
		$-8.5V \leq V_{in} \leq -21V$ , $10mA \leq I_{out} \leq 1A$ , $PD \leq 15W$	-6.3	-6	-6.3		
Line Regulation	REGline	$T_j = 25^{\circ}C$	$-8.5V \leq V_{in} \leq -25V$	--	5	120	mV
			$-9V \leq V_{in} \leq -13V$	--	1.5	60	
Load Regulation	REGload	$T_j = 25^{\circ}C$	$10mA \leq I_{out} \leq 1A$	--	14	120	
			$250mA \leq I_{out} \leq 750mA$	--	4	60	
Quiescent Current	Iq	$I_{out} = 0$ , $T_j = 25^{\circ}C$	--	4	8	mA	
Quiescent Current Change	$\Delta Iq$	$-8.5V \leq V_{in} \leq -25V$	--	--	1.3		
		$10mA \leq I_{out} \leq 1A$	--	--	0.5		
Output Noise Voltage	Vn	$10Hz \leq f \leq 100KHz$ , $T_j = 25^{\circ}C$	--	44	--	$\mu V$	
Ripple Rejection Ratio	RR	$f = 120Hz$ , $-9V \leq V_{in} \leq -19V$	60	73	--	dB	
Voltage Drop	Vdrop	$I_{out} = 1.0A$ , $T_j = 25^{\circ}C$	--	2	--	V	
Peak Output Current	I <sub>o peak</sub>	$T_j = 25^{\circ}C$	--	2.1	--	A	
Temperature Coefficient of Output Voltage	$\Delta V_{out}/\Delta T_j$	$I_{out} = 10mA$ , $0^{\circ}C \leq T_j \leq 125^{\circ}C$	--	-1	--	mV/ $^{\circ}C$	

- Pulse testing techniques are used to maintain the junction temperature as close to the ambient temperature as possible, and thermal effects must be taken into account separately.
- This specification applies only for DC power dissipation permitted by absolute maximum ratings.



### TS7908 Electrical Characteristics

( $V_{in} = -14V$ ,  $I_{out} = 500mA$ ,  $0^{\circ}C \leq T_j \leq 125^{\circ}C$ ,  $C_{in} = 0.33\mu F$ ,  $C_{out} = 0.1\mu F$ ; unless otherwise specified.)

Parameter	Symbol	Test Conditions	Min	Typ	Max	Unit	
Output Voltage	Vout	$T_j = 25^{\circ}C$	-7.69	-8	-8.32	V	
		$-10.5V \leq V_{in} \leq -23V$ , $10mA \leq I_{out} \leq 1A$ , $PD \leq 15W$	-7.61	-8	-8.40		
Line Regulation	REGline	$T_j = 25^{\circ}C$	$-10.5V \leq V_{in} \leq -25V$	--	6	160	mV
			$-11V \leq V_{in} \leq -17V$	--	2	80	
Load Regulation	REGload	$T_j = 25^{\circ}C$	$10mA \leq I_{out} \leq 1A$	--	12	160	mV
			$250mA \leq I_{out} \leq 750mA$	--	4	80	
Quiescent Current	Iq	$I_{out} = 0$ , $T_j = 25^{\circ}C$	--	4	8	mA	
Quiescent Current Change	$\Delta Iq$	$-10.5V \leq V_{in} \leq -25V$	--	--	1		
		$10mA \leq I_{out} \leq 1A$	--	--	0.5		
Output Noise Voltage	Vn	$10Hz \leq f \leq 100KHz$ , $T_j = 25^{\circ}C$	--	52	--	$\mu V$	
Ripple Rejection Ratio	RR	$f = 120Hz$ , $-11V \leq V_{in} \leq -21V$	56	72	--	dB	
Voltage Drop	Vdrop	$I_{out} = 1.0A$ , $T_j = 25^{\circ}C$	--	2	--	V	
Peak Output Current	I <sub>o peak</sub>	$T_j = 25^{\circ}C$	--	2.1	--	A	
Temperature Coefficient of Output Voltage	$\Delta V_{out}/\Delta T_j$	$I_{out} = 10mA$ , $0^{\circ}C \leq T_j \leq 125^{\circ}C$	--	-1	--	$mV/^{\circ}C$	

### TS7909 Electrical Characteristics

( $V_{in} = -15V$ ,  $I_{out} = 500mA$ ,  $0^{\circ}C \leq T_j \leq 125^{\circ}C$ ,  $C_{in} = 0.33\mu F$ ,  $C_{out} = 0.1\mu F$ ; unless otherwise specified.)

Parameter	Symbol	Test Conditions	Min	Typ	Max	Unit	
Output Voltage	Vout	$T_j = 25^{\circ}C$	-8.65	-9	-9.36	V	
		$-11.5V \leq V_{in} \leq -23V$ , $10mA \leq I_{out} \leq 1A$ , $PD \leq 15W$	-8.57	-9	-9.45		
Line Regulation	REGline	$T_j = 25^{\circ}C$	$-11.5V \leq V_{in} \leq -26V$	--	6	180	mV
			$-12V \leq V_{in} \leq -17V$	--	2	90	
Load Regulation	REGload	$T_j = 25^{\circ}C$	$10mA \leq I_{out} \leq 1A$	--	12	180	mV
			$250mA \leq I_{out} \leq 750mA$	--	4	90	
Quiescent Current	Iq	$I_{out} = 0$ , $T_j = 25^{\circ}C$	--	4	8	mA	
Quiescent Current Change	$\Delta Iq$	$-11.5V \leq V_{in} \leq -26V$	--	--	1		
		$10mA \leq I_{out} \leq 1A$	--	--	0.5		
Output Noise Voltage	Vn	$10Hz \leq f \leq 100KHz$ , $T_j = 25^{\circ}C$	--	58	--	$\mu V$	
Ripple Rejection Ratio	RR	$f = 120Hz$ , $-12V \leq V_{in} \leq -22V$	56	71	--	dB	
Voltage Drop	Vdrop	$I_{out} = 1.0A$ , $T_j = 25^{\circ}C$	--	2	--	V	
Peak Output Current	I <sub>o peak</sub>	$T_j = 25^{\circ}C$	--	2.1	--	A	
Temperature Coefficient of Output Voltage	$\Delta V_{out}/\Delta T_j$	$I_{out} = 10mA$ , $0^{\circ}C \leq T_j \leq 125^{\circ}C$	--	-1	--	$mV/^{\circ}C$	

- Pulse testing techniques are used to maintain the junction temperature as close to the ambient temperature as possible, and thermal effects must be taken into account separately.
- This specification applies only for DC power dissipation permitted by absolute maximum ratings.



### TS7912 Electrical Characteristics

( $V_{in}=-19V$ ,  $I_{out}=500mA$ ,  $0^{\circ}C \leq T_j \leq 125^{\circ}C$ ,  $C_{in}=0.33\mu F$ ,  $C_{out}=0.1\mu F$ ; unless otherwise specified.)

Parameter	Symbol	Test Conditions	Min	Typ	Max	Unit	
Output Voltage	Vout	$T_j=25^{\circ}C$	-11.53	-12	-12.48	V	
		$-14.5V \leq V_{in} \leq -27V$ , $10mA \leq I_{out} \leq 1A$ , $PD \leq 15W$	-11.42	-12	-12.60		
Line Regulation	REGline	$T_j=25^{\circ}C$	$-14.5V \leq V_{in} \leq -30V$	--	10	240	mV
			$-15V \leq V_{in} \leq -19V$	--	3	120	
Load Regulation	REGload	$T_j=25^{\circ}C$	$10mA \leq I_{out} \leq 1A$	--	12	240	mV
			$250mA \leq I_{out} \leq 750mA$	--	4	120	
Quiescent Current	Iq	$T_j=25^{\circ}C$ , $I_{out}=0$	--	4	8	mA	
Quiescent Current Change	$\Delta Iq$	$-14.5V \leq V_{in} \leq -30V$	--	--	1		
		$10mA \leq I_{out} \leq 1A$	--	--	0.5		
Output Noise Voltage	Vn	$10Hz \leq f \leq 100KHz$ , $T_j=25^{\circ}C$	--	75	--	$\mu V$	
Ripple Rejection Ratio	RR	$f=120Hz$ , $15V \leq V_{in} \leq 25V$	55	70	--	dB	
Voltage Drop	Vdrop	$I_{out}=1.0A$ , $T_j=25^{\circ}C$	--	2	--	V	
Peak Output Current	I <sub>o peak</sub>	$T_j=25^{\circ}C$	--	2.1	--	A	
Temperature Coefficient of Output Voltage	$\Delta V_{out}/\Delta T_j$	$I_{out}=10mA$ , $0^{\circ}C \leq T_j \leq 125^{\circ}C$	--	-1	--	$mV/^{\circ}C$	

### TS7915 Electrical Characteristics

( $V_{in}=-23V$ ,  $I_{out}=500mA$ ,  $0^{\circ}C \leq T_j \leq 125^{\circ}C$ ,  $C_{in}=0.33\mu F$ ,  $C_{out}=0.1\mu F$ ; unless otherwise specified.)

Parameter	Symbol	Test Conditions	Min	Typ	Max	Unit	
Output Voltage	Vout	$T_j=25^{\circ}C$	-14.42	-15	-15.60	V	
		$-17.5V \leq V_{in} \leq -30V$ , $10mA \leq I_{out} \leq 1A$ , $PD \leq 15W$	-14.28	-15	-15.75		
Line Regulation	REGline	$T_j=25^{\circ}C$	$-17.5V \leq V_{in} \leq -30V$	--	12	300	mV
			$-18V \leq V_{in} \leq -22V$	--	3	150	
Load Regulation	REGload	$T_j=25^{\circ}C$	$10mA \leq I_{out} \leq 1A$	--	12	300	mV
			$250mA \leq I_{out} \leq 750mA$	--	4	150	
Quiescent Current	Iq	$T_j=25^{\circ}C$ , $I_{out}=0$	--	4	8	mA	
Quiescent Current Change	$\Delta Iq$	$-17.5V \leq V_{in} \leq -30V$	--	--	1		
		$10mA \leq I_{out} \leq 1A$	--	--	0.5		
Output Noise Voltage	Vn	$10Hz \leq f \leq 100KHz$ , $T_j=25^{\circ}C$	--	90	--	$\mu V$	
Ripple Rejection Ratio	RR	$f=120Hz$ , $-18V \leq V_{in} \leq -28V$	54	69	--	dB	
Voltage Drop	Vdrop	$I_{out}=1.0A$ , $T_j=25^{\circ}C$	--	2	--	V	
Peak Output Current	I <sub>o peak</sub>	$T_j=25^{\circ}C$	--	2.1	--	A	
Temperature Coefficient of Output Voltage	$\Delta V_{out}/\Delta T_j$	$I_{out}=10mA$ , $0^{\circ}C \leq T_j \leq 125^{\circ}C$	--	-1	--	$mV/^{\circ}C$	

- Pulse testing techniques are used to maintain the junction temperature as close to the ambient temperature as possible, and thermal effects must be taken into account separately.
- This specification applies only for DC power dissipation permitted by absolute maximum ratings.



### TS79818 Electrical Characteristics

( $V_{in}=-27V$ ,  $I_{out}=500mA$ ,  $0^{\circ}C \leq T_j \leq 125^{\circ}C$ ,  $C_{in}=0.33\mu F$ ,  $C_{out}=0.1\mu F$ ; unless otherwise specified.)

Parameter	Symbol	Test Conditions	Min	Typ	Max	Unit	
Output Voltage	$V_{out}$	$T_j=25^{\circ}C$	-17.30	-18	-18.72	V	
		$-21V \leq V_{in} \leq -33V$ , $10mA \leq I_{out} \leq 1A$ , $PD \leq 15W$	-17.14	-18	-18.90		
Line Regulation	REGline	$T_j=25^{\circ}C$	$-21V \leq V_{in} \leq -33V$	--	15	360	mV
			$-22V \leq V_{in} \leq -26V$	--	5	180	
Load Regulation	REGload	$T_j=25^{\circ}C$	$10mA \leq I_{out} \leq 1A$	--	12	360	mV
			$250mA \leq I_{out} \leq 750mA$	--	4	180	
Quiescent Current	$I_q$	$T_j=25^{\circ}C$ , $I_{out}=0$	--	4	8	mA	
Quiescent Current Change	$\Delta I_q$	$-21V \leq V_{in} \leq -33V$	--	--	1		
		$10mA \leq I_{out} \leq 1A$	--	--	0.5		
Output Noise Voltage	$V_n$	$10Hz \leq f \leq 100KHz$ , $T_j=25^{\circ}C$	--	110	--	$\mu V$	
Ripple Rejection Ratio	RR	$f=120Hz$ , $-21V \leq V_{in} \leq -31V$	53	68	--	dB	
Voltage Drop	$V_{drop}$	$I_{out}=1.0A$ , $T_j=25^{\circ}C$	--	2	--	V	
Peak Output Current	$I_{o\ peak}$	$T_j=25^{\circ}C$	--	2.1	--	A	
Temperature Coefficient of Output Voltage	$\Delta V_{out}/\Delta T_j$	$I_{out}=10mA$ , $0^{\circ}C \leq T_j \leq 125^{\circ}C$	--	-1	--	$mV/^{\circ}C$	

### TS7824 Electrical Characteristics

( $V_{in}=-33V$ ,  $I_{out}=500mA$ ,  $0^{\circ}C \leq T_j \leq 125^{\circ}C$ ,  $C_{in}=0.33\mu F$ ,  $C_{out}=0.1\mu F$ ; unless otherwise specified.)

Parameter	Symbol	Test Conditions	Min	Typ	Max	Unit	
Output Voltage	$V_{out}$	$T_j=25^{\circ}C$	-23.07	-24	-24.96	V	
		$-27V \leq V_{in} \leq -38V$ , $10mA \leq I_{out} \leq 1A$ , $PD \leq 15W$	-22.85	-24	-25.20		
Line Regulation	REGline	$T_j=25^{\circ}C$	$-27V \leq V_{in} \leq -38V$	--	18	480	mV
			$-28V \leq V_{in} \leq -32V$	--	6	240	
Load Regulation	REGload	$T_j=25^{\circ}C$	$10mA \leq I_{out} \leq 1A$	--	12	480	mV
			$250mA \leq I_{out} \leq 750mA$	--	4	240	
Quiescent Current	$I_q$	$I_{out}=0$ , $T_j=25^{\circ}C$	--	4	8	mA	
Quiescent Current Change	$\Delta I_q$	$-27V \leq V_{in} \leq -38V$	--	--	1		
		$10mA \leq I_{out} \leq 1A$	--	--	0.5		
Output Noise Voltage	$V_n$	$10Hz \leq f \leq 100KHz$ , $T_j=25^{\circ}C$	--	170	--	$\mu V$	
Ripple Rejection Ratio	RR	$f=120Hz$ , $-27V \leq V_{in} \leq -37V$	50	65	--	dB	
Voltage Drop	$V_{drop}$	$I_{out}=1.0A$ , $T_j=25^{\circ}C$	--	2	--	V	
Peak Output Current	$I_{o\ peak}$	$T_j=25^{\circ}C$	--	2.1	--	A	
Temperature Coefficient of Output Voltage	$\Delta V_{out}/\Delta T_j$	$I_{out}=10mA$ , $0^{\circ}C \leq T_j \leq 125^{\circ}C$	--	-1	--	$mV/^{\circ}C$	

- Pulse testing techniques are used to maintain the junction temperature as close to the ambient temperature as possible, and thermal effects must be taken into account separately.
- This specification applies only for DC power dissipation permitted by absolute maximum ratings.

## Electrical Characteristics Curve

**FIGURE 1 - Worst Case Power Dissipation v.s. Ambient Temperature**

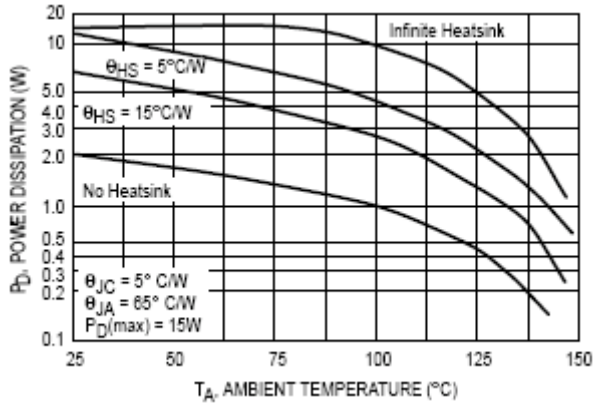

**FIGURE 2 - Peak Output Current v.s. Input-Output Differential Voltage**

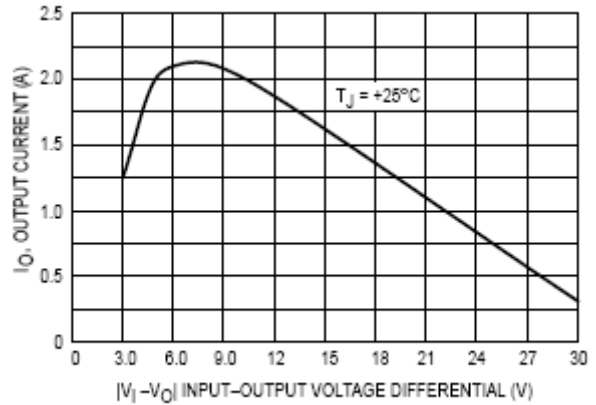

**FIGURE 3 - Ripple Rejection v.s. Frequency**

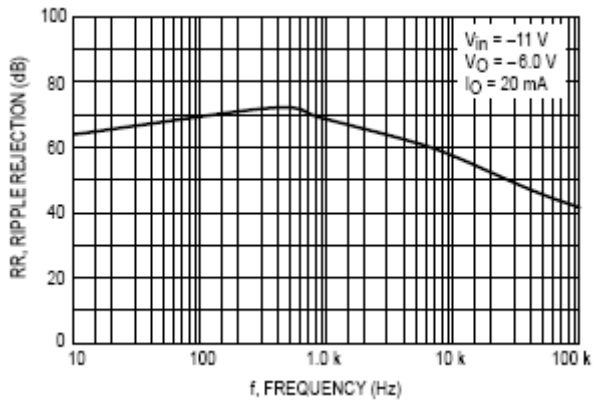

**FIGURE 4 - Ripple Rejection v.s. Output Voltage**

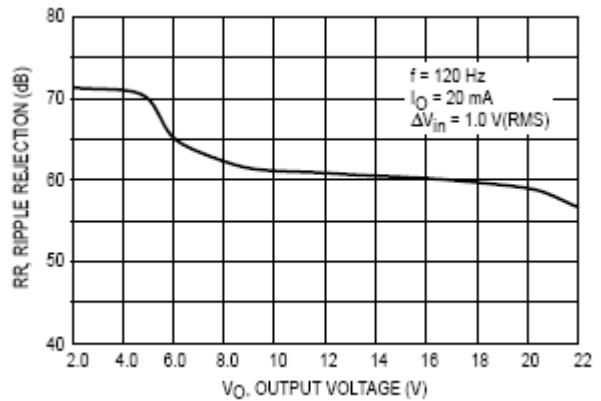

**FIGURE 5 - Output Voltage v.s. Junction Temperature**

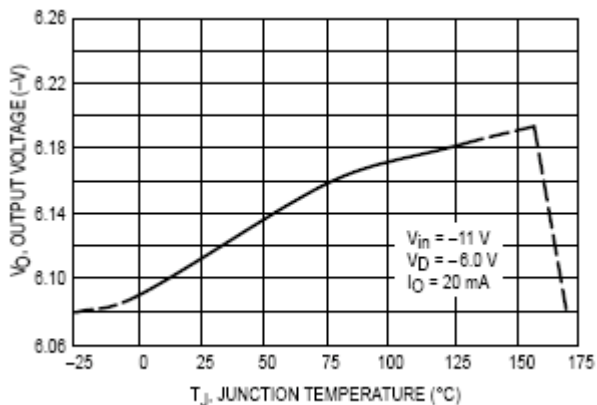

**FIGURE 6 - Quiescent Current v.s. Temperature**

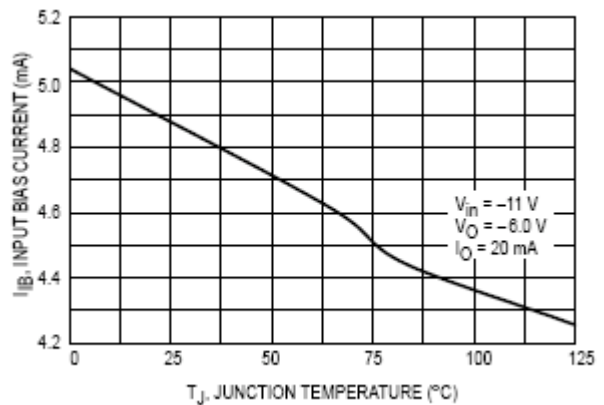

## TO-220 Mechanical Drawing

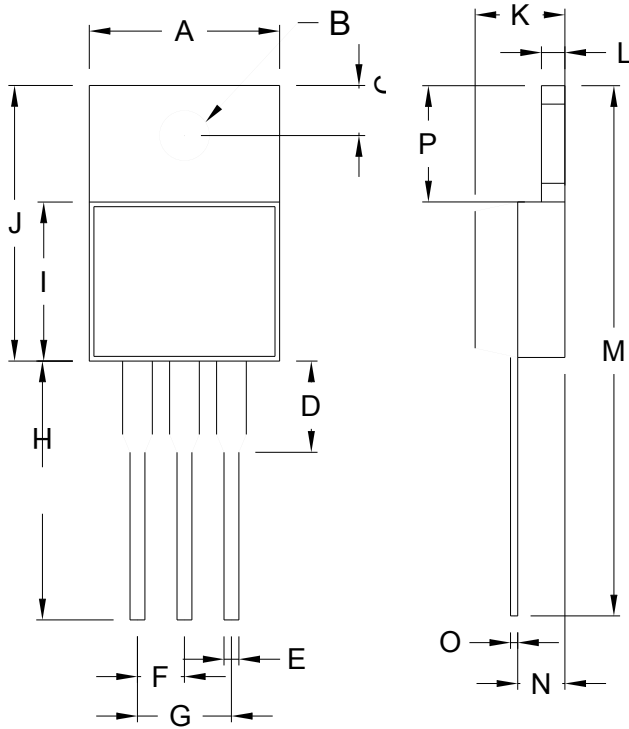

TO-220 DIMENSION				
DIM	MILLIMETERS		INCHES	
	MIN	MAX	MIN	MAX
A	10.000	10.500	0.394	0.413
B	3.240	4.440	0.128	0.175
C	2.440	2.940	0.096	0.116
D	-	6.350	-	0.250
E	0.381	1.106	0.015	0.040
F	2.345	2.715	0.092	0.058
G	4.690	5.430	0.092	0.107
H	12.700	14.732	0.500	0.581
I	8.382	9.017	0.330	0.355
J	14.224	16.510	0.560	0.650
K	3.556	4.826	0.140	0.190
L	0.508	1.397	0.020	0.055
M	27.700	29.620	1.060	1.230
N	2.032	2.921	0.080	0.115
O	0.255	0.610	0.010	0.024
P	5.842	6.858	0.230	0.270

## ITO-220 Mechanical Drawing

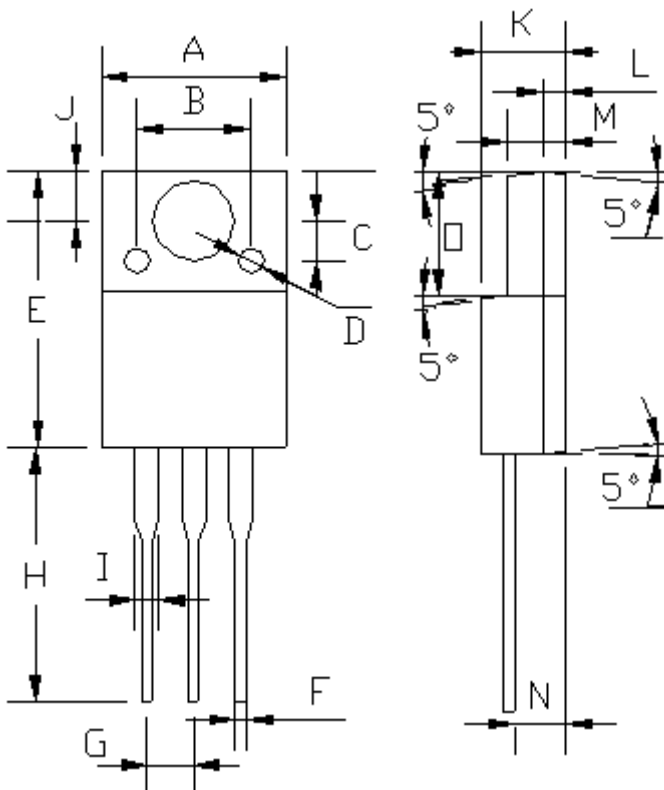

ITO-220 DIMENSION				
DIM	MILLIMETERS		INCHES	
	MIN	MAX	MIN	MAX
A	10.04	10.07	0.395	0.396
B	6.20 (typ.)		0.244 (typ.)	
C	2.20 (typ.)		0.087 (typ.)	
D	§ 1.40 (typ.)		§ 0.055 (typ.)	
E	15.0	15.20	0.591	0.598
F	0.52	0.54	0.020	0.021
G	2.35	2.73	0.093	0.107
H	13.50	13.55	0.531	0.533
I	1.11	1.49	0.044	0.058
J	2.60	2.80	0.102	0.110
K	4.49	4.50	0.176	0.177
L	1.15 (typ.)		0.045 (typ.)	
M	3.03	3.05	0.119	0.120
N	2.60	2.80	0.102	0.110
O	6.55	6.65	0.258	0.262