



MBS2 THRU MBS10

Single Phase 0.8 AMPS. Glass Passivated Bridge Rectifiers



Voltage Range
200 to 1000 Volts
Current
0.8 Amperes

Features

- ✧ Ideal for printed circuit board
- ✧ Reliable low cost construction utilizing molded plastic technique
- ✧ High surge current capability
- ✧ High temperature soldering guaranteed: 260°C / 10 seconds at 5 lbs., (2.3 kg) tension
- ✧ Small size, simple installation
- ✧ Leads solderable per MIL-STD-202 Method 208

MBS

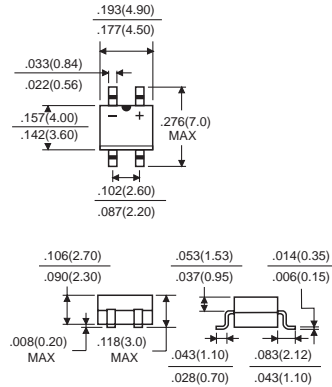

Dimensions in inches and (millimeters)

Maximum Ratings and Electrical Characteristics

Rating at 25°C ambient temperature unless otherwise specified.

Single phase, half wave, 60 Hz, resistive or inductive load.

For capacitive load, derate current by 20%

Type Number	Symbol	MBS2	MBS4	MBS6	MBS8	MBS10	Units
Maximum Recurrent Peak Reverse Voltage	V_{RRM}	200	400	600	800	1000	V
Maximum RMS Voltage	V_{RMS}	140	280	420	560	700	V
Maximum DC Blocking Voltage	V_{DC}	200	400	600	800	1000	V
Maximum Average Forward Rectified Current On glass-epoxy P.C.B. On aluminum substrate	$I_{(AV)}$			0.5 0.8			A
Peak Forward Surge Current, 8.3 ms Single Half Sine-wave Superimposed on Rated Load (JEDEC method)	I_{FSM}			35			A
Maximum Instantaneous Forward Voltage @ 0.4A	V_F			1.0			V
Maximum DC Reverse Current @ $T_A=25^\circ\text{C}$ at Rated DC Blocking Voltage @ $T_A=125^\circ\text{C}$	I_R			5.0 100			μA μA
Typical Junction Capacitance Per Leg (Note1)	C_j			13			pF
Typical Thermal Resistance Per Leg	$R_{\theta JA}$			85			$^\circ\text{C}/\text{W}$
Operating Temperature Range	T_J			-55 to +150			$^\circ\text{C}$
Storage Temperature Range	T_{STG}			-55 to +150			$^\circ\text{C}$

Note: 1. Measured at 1.0 MHZ and Applied Reverse Voltage of 4.0 Volts D.C.

RATINGS AND CHARACTERISTIC CURVES (MBS2 THRU MBS10)

