

10/100 BASE FILTER WITH CONNECTOR MODEL NO. : RJLD-043TC1

Features:

- ⊙ RoHS Compliant
- ⊙ Fully shielded magnetics protect data from internally generated digital noise
- ⊙ Reduces the overall length of the signal path for improved common mode performance
- ⊙ Implements full common mode termination scheme with used and unused twisted pairs
- ⊙ Meets IEEE802.3 Baseline Wander Compensation specification
- ⊙ Integrates high voltage capacitor to chassis ground
- ⊙ Supports all major transceivers with matched turns ration and complete integration of specified termination
- ⊙ Design for 100base-tx transmission over UTP-5 cable
- ⊙ Operating TEMP. range : -40°C to +85°C
- ⊙ Storage TEMP. range : -55°C to +125°C
- ⊙ Primary OCL inductance : 350μH MIN. at 100KHz/100mV with 8mA DC bias
- ⊙ With the LED lamp

Typical Performance Characteristics@ 25°C

Insertion Loss (dB MAX)	Return Loss (dB Min @100±15Ω)				Differential to Common Mode Rejection (dB MIN)	Cross talk (dB MIN)					CMRR (dB MIN)	Isolation Voltage (Vrms min)
MHz	MHz				MHz	MHz					MHz	1500
1~100	1~30	40	50	60~80	1~100	20	40	60	80	100	1~100	
-1.0	-16	-14	-12	-10	-33	-47	-40	-37	-35	-33	-30	

Schematic Design on MDI Interface Circuitry

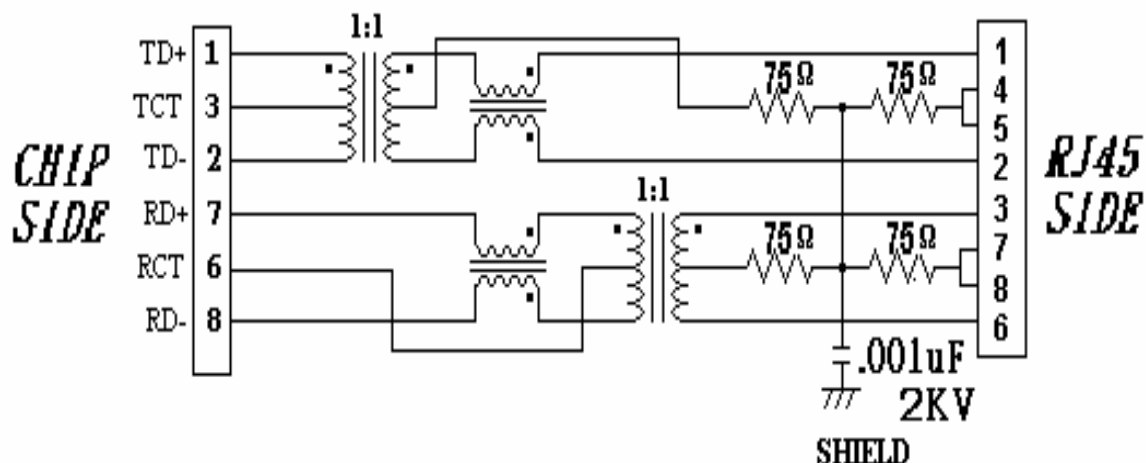

MODEL NO. : RJLD-043TC1

Dimension: mm

TOLERANCE:±0.15 (Unless otherwise specified)

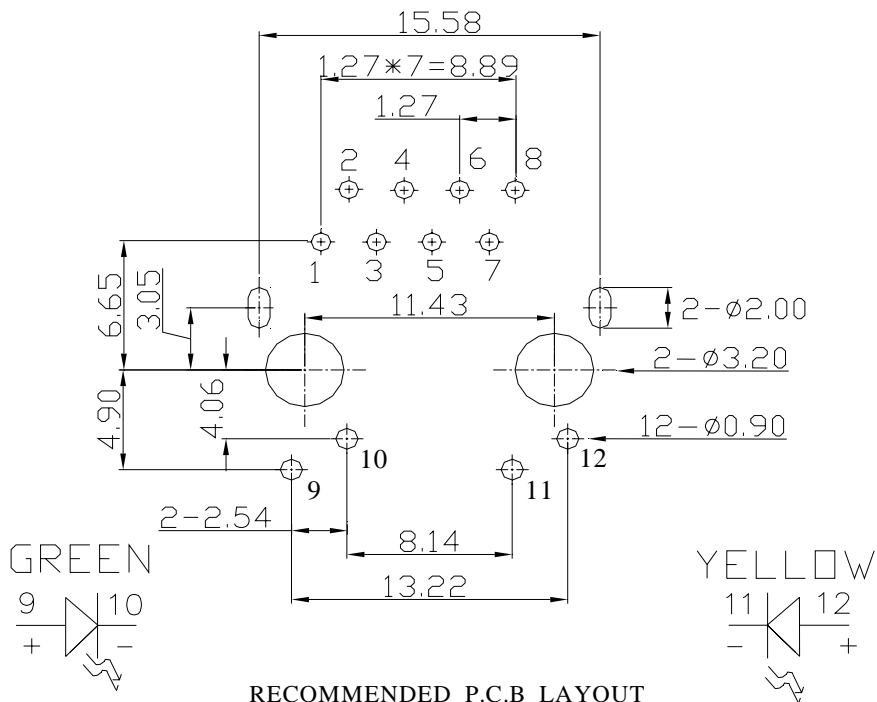
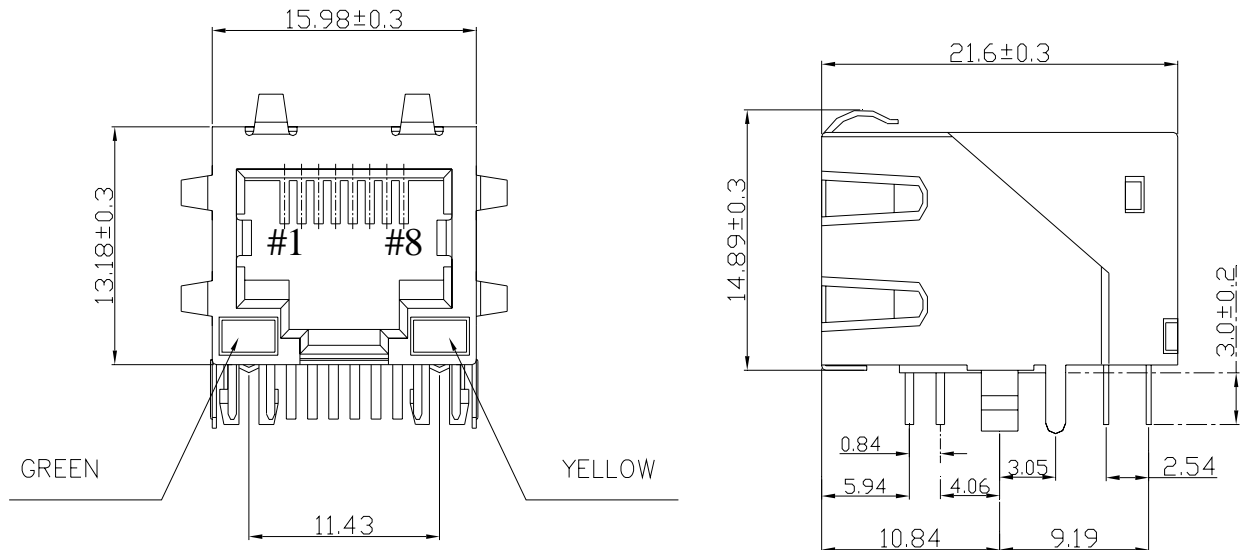

RECOMMENDED P.C.B LAYOUT
COMPONENT SIDE OF BOARD



NUMBER:RD-SDRJLD-043TC1
DATE :2006/02/20 S(REV:A1)

MODEL NO. : RJLD-043TC1

Ordering Information

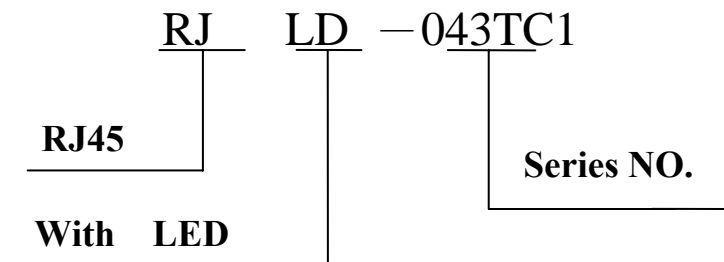

Requirements :

1. Design and Construction

Product shall be of design, construction and physical dimensions specified on applicable product drawing.

2. Materials and Finish

A. Contact:

RJ Contact : Phosphor Bronze, Thickness=0.30mm

Finish : Contact Area : 6 μ "min. Gold over 50 μ "min. Nickel

RJ Joint Contact : Brass, Thickness=0.30mm

Finish : 80 μ "min. Sn over 50 μ "min. Nickel

LED Joint Contact : Brass, Thickness=0.50mm

Finish : 80 μ "min. Sn over 50 μ "min. Nickel

B. Plastic Part :

(1) Set Housing : Thermoplastic, PBT, Black

UL FILE NO. : E107536

Manufacturer : SHIKONG SYNTHETIC FIBERS CORP.

Grade : E202G30BK

Flame Class : UL 94V-0

(2) Insert : Thermoplastic, PBT, Black

UL FILE NO. : E107536

Manufacturer : SHIKONG SYNTHETIC FIBERS CORP.

Grade : E202G30BK

Flame Class : UL 94V-0

(3) Spacer : Thermoplastic, PBT, Black

UL FILE NO. : E107536

Manufacturer : SHIKONG SYNTHETIC FIBERS CORP.

Grade : E202G30BK

Flame Class : UL 94V-0

C. Shield Material :

Cartridge t=0.25mm

10 μ "-20 μ " Thick Nickel over Brass



NUMBER:RD-SDRJLD-043TC1
DATE :2006/02/20 S(REV:A1)

MODEL NO. : RJLD-043TC1

D. LED Lamp

- (a) Lens Color : Transparent with color
- (b) Emitted Color : Green & Yellow
- (c) View Angle : 65°
- (d) Wave Length : Green 565nm ; Yellow 585nm
- (e) Recommended operation current (IF) : 20 mA

3. Ratings

- (1) Voltage rating : 125 VAC
- (2) Current rating : 1.5A

Durability :

- (1) 1000 cycles with no function damage for RJ-45 . Abnormalities shall be present after the test.
- (2) Low Level Contact Resistance : $\Delta R=30m\Omega$ maximum (final)
- (3) The sample should be mounted in the tester and fully mated and unmated 500 times per hour at the rate of 25mm/min.EIA-364-09C.



NUMBER:RD-SDRJLD-043TC1
DATE :2006/02/20 S(REV:A1)

MODEL NO. : RJLD-043TC1

1. Unit weight :5.7 grams
2. package : 100 pcs / tray / 0.61 kgms
3. Carton : 1000 pcs / 10 layers of tray
4. Gross weight : 6.6455 kgms

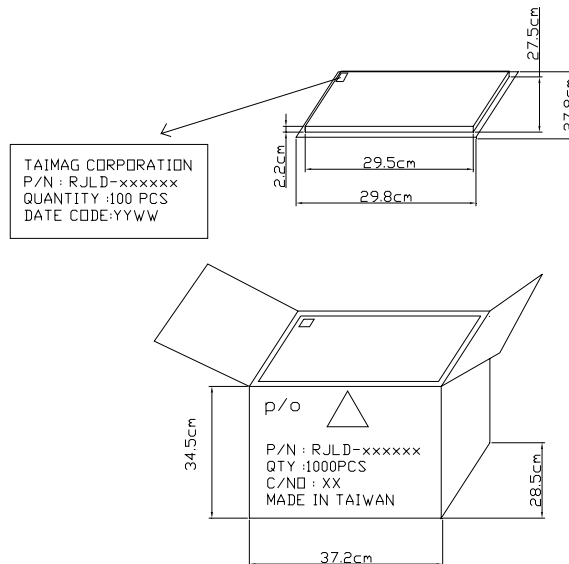



NUMBER:RD-SDRJLD-043TC1
DATE :2006/02/20 S(REV:A1)

MODEL NO. : RJLD-043TC1

REV.	Revision Description	DATE
A1	First Release	2006/02/20