

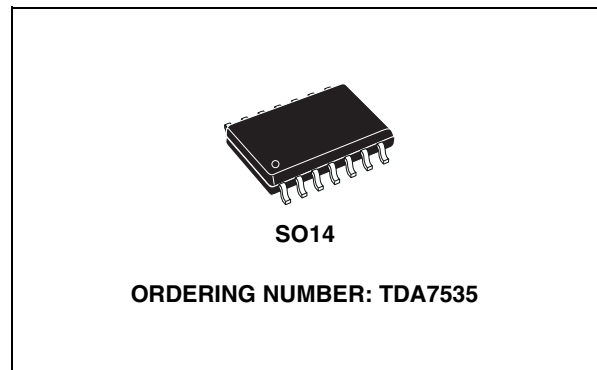

DELTA/SIGMA CASCADE 20 BIT STEREO DAC

- 20-bit resolution single ended output
- Analog reconstruction third order Chebyshev filter
- I²S input data format
- On chip PLL
- System clock: 64 F_s
- 2 output channels
- 0.9 VRMS single ended output dynamic
- 3.3V power supply
- Reset
- Sampling rate 36KHz to 48KHz



DESCRIPTION

The TDA7535 is a stereo, digital-to-analog converter designed for audio application, including digital interpolation filter, a third order multibit Delta-Sigma DAC, a third order Chebyshev's reconstruction filter and a differential to single ended output converter. This device is fabricated in highly advanced CMOS, where high speed precision analog circuits are combined with high density logic circuits. The TDA7535, according to standard audio converters, can accept any I²S data format.

The TDA7535 is available in SO14 package. The total power consumption is less than 75mW.

TDA7535 is suitable for a wide variety of applications where high performance are required. Its low cost and single 3.3V power supply make it ideal for several applications, such as CD players, MPEG audio, MIDI applications, CD-ROM drives, CD-Interactive, digital radio applications and so on. An evaluation board is available to perform measurement and to make listening tests.

BLOCK DIAGRAM

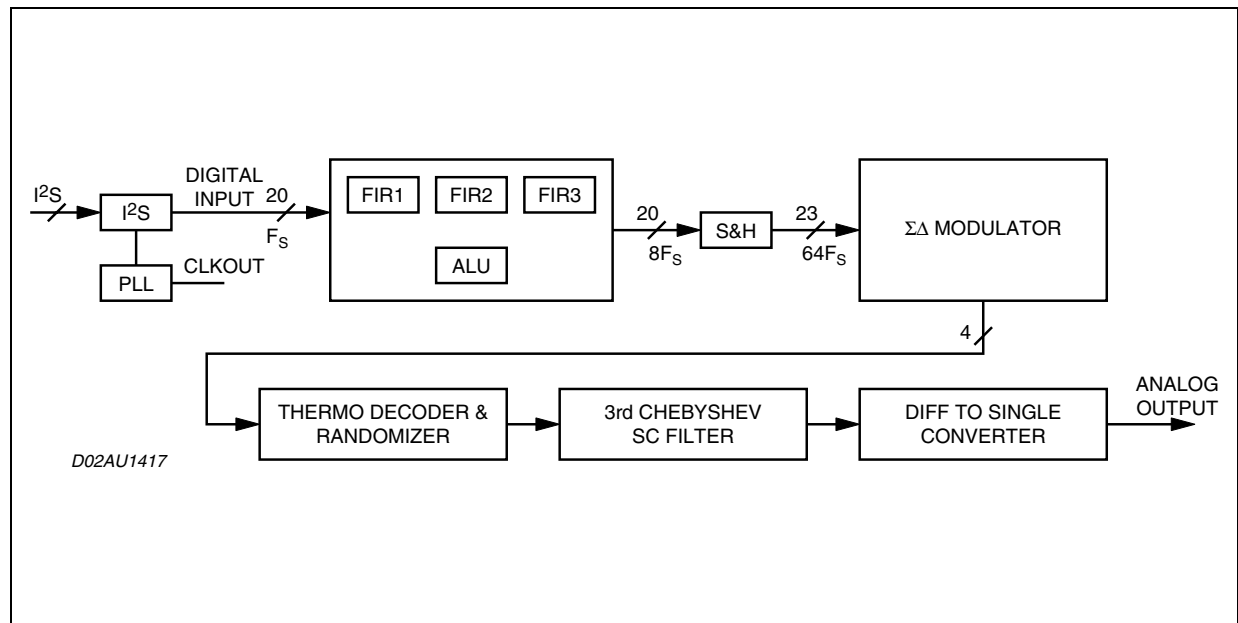

TDA7535

ABSOLUTE MAXIMUM RATINGS

Symbol	Parameter	Value	Unit
V _{DD}	Power supplies	Digital	-0.5 to +4.6
V _{CC}		Analog	-0.5 to +4.6
V _{aio}	Analog Input and Output Voltage	-0.5 to (V _{CC} +0.5)	V
V _{dio}	Digital Input and Output Voltage	-0.5 to (V _{DD} +0.5)	V
V _{di5}	Digital Input Voltage (5V tolerant)	-0.5 to 6.5	V
T _j	Operating Junction Temperature Range	-40 to 125	°C
T _{stg}	Storage Temperature	-55 to 150	°C

Warning: Operation at or beyond these limit may result in permanent damage to the device. Normal operation is not guaranteed at these extremes.

THERMAL DATA

Symbol	Parameter	Value	Unit
R _{th j-amb}	Thermal resistance junction to ambient ⁽¹⁾	85	°C/W

Note: 1. In still air

PIN CONNECTIONS (Top view)

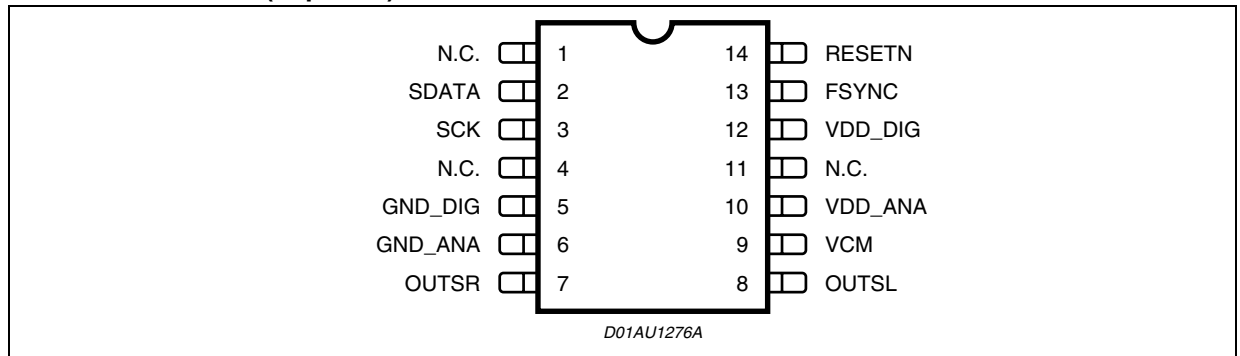

PIN FUNCTION

Pin Number	Pin Name	Input/Output Power	Description
1	N.C.	-	-
2	SDATA	I	I2S Digital Data Input
3	SCK	I	I2S Clock Input
4	N.C.	-	-
5	GND_DIG	P	Digital Ground
6	GND_ANA	P	Analog Ground
7	OUTSR	O	Right Channel single ended Output
8	OUTSL	O	Left Channel single ended Output
9	VCM	P	Reference 1.65V externally filtered
10	VDD_ANA	P	Analog 3.3V-Supply
11	N.C.	-	-
12	VDD_DIG	P	Digital 3.3V-Supply
13	FSYNC	I	I2S Left-Right Channel selector
14	RESETN	I	Reset (active low)

RECOMMENDED DC OPERATING CONDITIONS

Symbol	Parameter	Test Condition	Min.	Typ.	Max.	Unit
V _{DD}	3.3V Digital Power Supply Voltage		3.15	3.3	3.45	V
V _{CC}	3.3V Analog Power Supply Voltage		3.15	3.3	3.45	V

POWER CONSUMPTION

Symbol	Parameter	Test Condition	Min.	Typ.	Max.	Unit
I _{dd}	Total Maximum Current	power supply @ 3.3V and T _j = 125°C		21.5	25	mA

GENERAL INTERFACE ELECTRICAL CHARACTERISTICS

Symbol	Parameter	Test Condition	Min.	Typ.	Max.	Unit
I _{ij}	Low Level Input Current without pullup device	V _i = 0V (note 1)			1	μA
I _{ih}	High Level Input Current without pullup device	V _i = V _{dd} (note 1)			1	μA
I _{latchup}	I/O latch-up current	V < 0V, V > V _{dd}	200			mA
V _{esd}	Electrostatic Protection	Leakage , 1μA (note 2)	2000			V

Note: 1. The leakage currents are generally very small, <1nA. The value given here, 1mA, is the maximum that can occur after an Electrostatic Stress on the pin.
2. Human Body Model.

LOW VOLTAGE CMOS INTERFACE DC ELECTRICAL CHARACTERISTICS

Symbol	Parameter	Test Condition	Min.	Typ.	Max.	Unit
V _{il}	Low Level Input Voltage				0.2*V _{dd}	V
V _{ih}	High Level Input Voltage		0.8*V _{dd}			V
V _{hyst}	Schmitt trigger hysteresis		0.8			V

DAC ELECTRICAL CHARACTERISTICS

V_{dd} = 3.3V; T_{amb} = 25°C; Input signal frequency = sinus wave generated by Audio Precision Sys.2; Input Signal Amplitude = see notes; Noise Integration Bandwidth = 20Hz to 22KHz (A- weighted)

Parameter	Test Condition	Min.	Typ.	Max.	Unit
Noise + Distortion (see note 1)	@0dB @-6dBb @-40dB @-60dB		89 94 96 96		dB dB dB dB
Total Harmonic Distortion	see note 2	70 ⁽⁵⁾	94		dB
Dynamic range	see note 3	84 ⁽⁶⁾	96		dB
Crosstalk	see note 4		-95		dB
Full Scale Output Voltage	V _{dd} = 3.15 to 3.45V Full scale input	0.8	0.9	1.0	V _{rms}
Input Sampling Rate		36		48	kHz
Passband Ripple			0.12		dB

DAC ELECTRICAL CHARACTERISTICS (continued)

Vdd = 3.3V; Tamb = 25°C; Input signal frequency = sinus wave generated by Audio Precision Sys.2; Input Signal Amplitude = see notes; Noise Integration Bandwidth = 20Hz to 22KHz (A- weighted)

Parameter	Test Condition	Min.	Typ.	Max.	Unit
Stopband	@ 3dB @ 90dB 44.1kHz Sampling Rate	21.53		24.80	kHz
Interchannel Gain Mismatch			0.05	0.1	dB

Note1: It is the ratio between the maximum input signal and the integration of the in-band noise after deducing the power of signal fundamental. It depends on the input signal amplitude. In this case 0dB means full scale digital, 1kHz frequency used.

Note 2: It is the ratio of the rms value of the signal fundamental component at 0dB (full scale digital) to the rms value of all of the harmonic components in the band.

Note 3: measured using the SNR at -60dB input signal, with 60dB added to compensate for small input signal.

Note 4: Left channel on with 0dB/1kHz input signal, Right channel on with DC input signal.

Note 5 by correlation to beuch results. ATE limits are 60dB

Note 6 by correlation to beuch results. ATE limits are 80dB

Figure 1. I²S interface Diagram

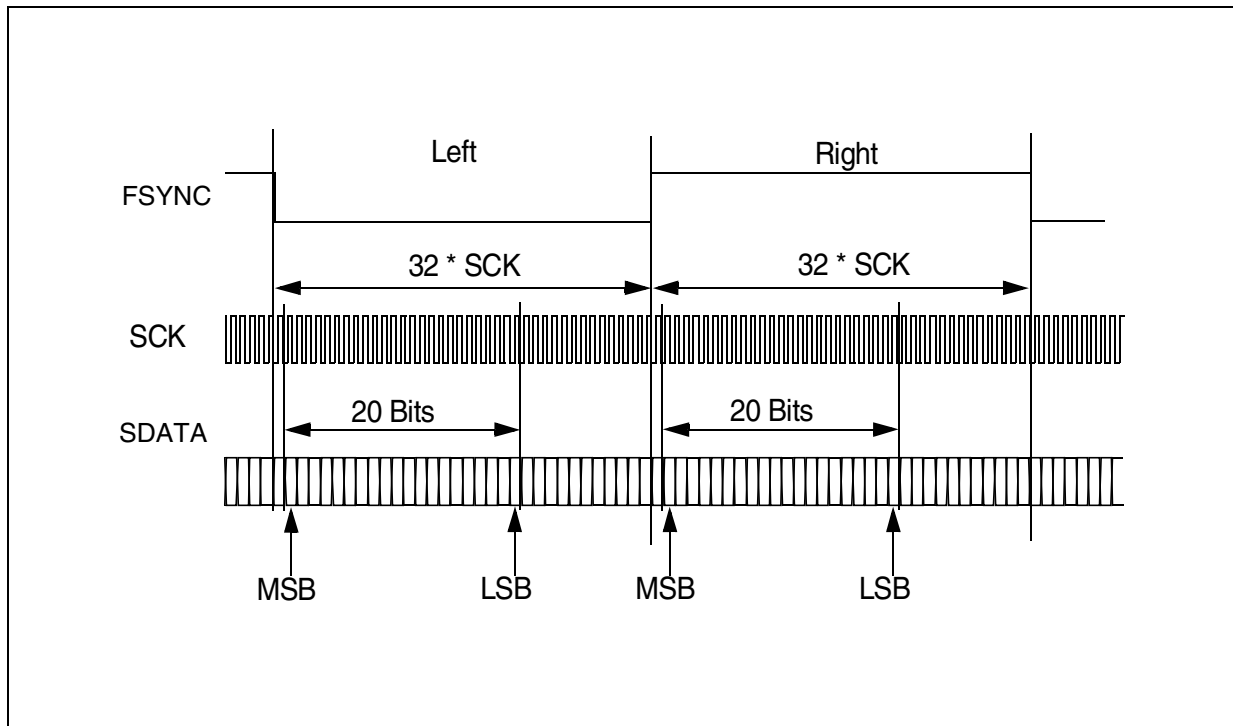
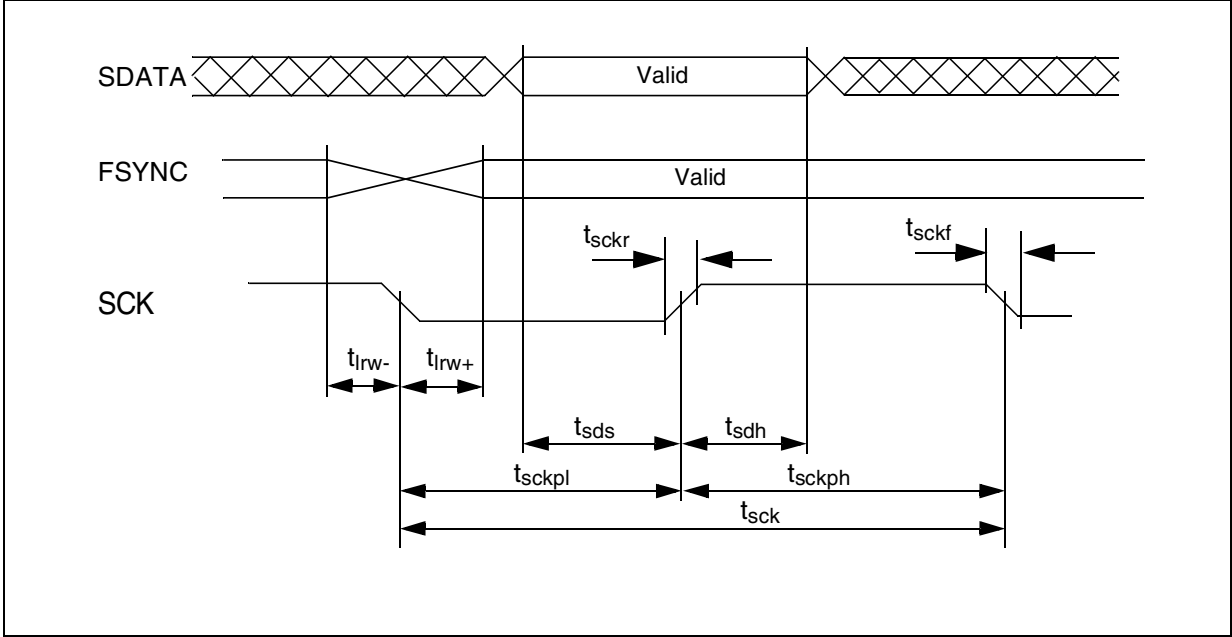

Figure 2. I²S Timings



Timing	Description	Minimum	Maximum	Unit
t_{sck}	Clock Cycle ⁽¹⁾	$1/(64 \cdot F_s) - 150\text{ps}_{\text{RMS}}$	$1/(64 \cdot F_s) + 150\text{ps}_{\text{RMS}}$	ns
t_{sckpl}	SCK Phase Low	$0.5 \cdot t_{sck} - 1\%$	$0.5 \cdot t_{sck} + 1\%$	ns
t_{sckph}	SCK Phase High	$0.5 \cdot t_{sck} - 1\%$	$0.5 \cdot t_{sck} + 1\%$	ns
t_{lrw-}	FSYNC switching time window before SCK falling edge ⁽²⁾	0	$0.125 \cdot t_{sck} - 10$	ns
t_{lrw+}	FSYNC switching time window after SCK falling edge ⁽²⁾	0	$0.125 \cdot t_{sck} - 10$	ns
t_{sds}	SDATA setup time	60		ns
t_{sdh}	SDATA hold time	30		ns
t_{sckr}	SCK rise time		22	ns
t_{sckf}	SCK fall time		20	ns

⁽¹⁾ SCK clock defines the F_s , being the Sample Rate. This input clock needs a jitter below $\sim 212\text{ps}_{\text{RMS}}$

⁽²⁾ FSYNC switches inside the time window as specified w.r.t. to falling edge of SCK

Figure 3. Power Up & Reset Sequence

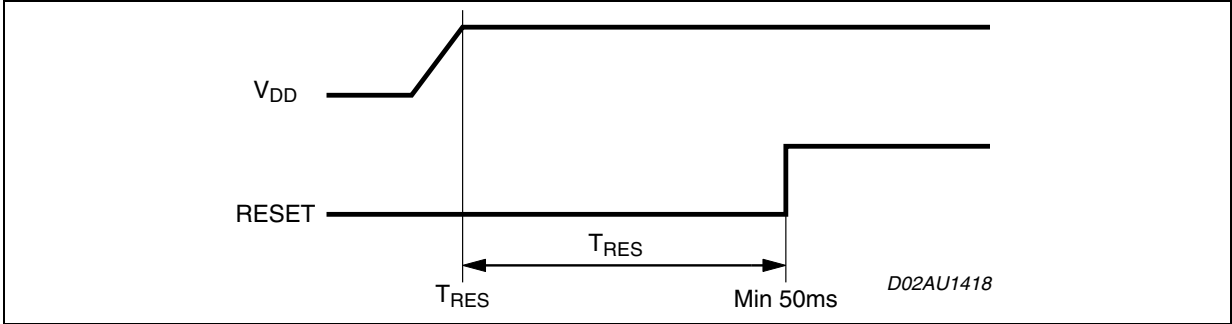

Figure 4. Frequency response

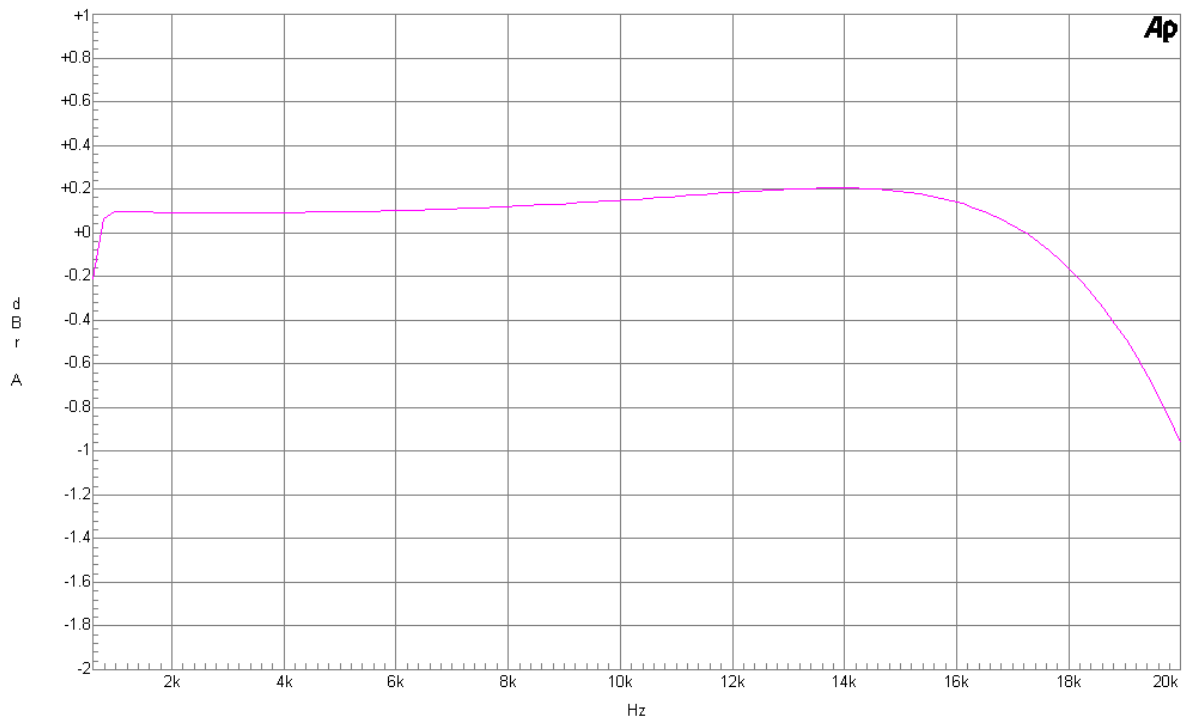

Figure 5.

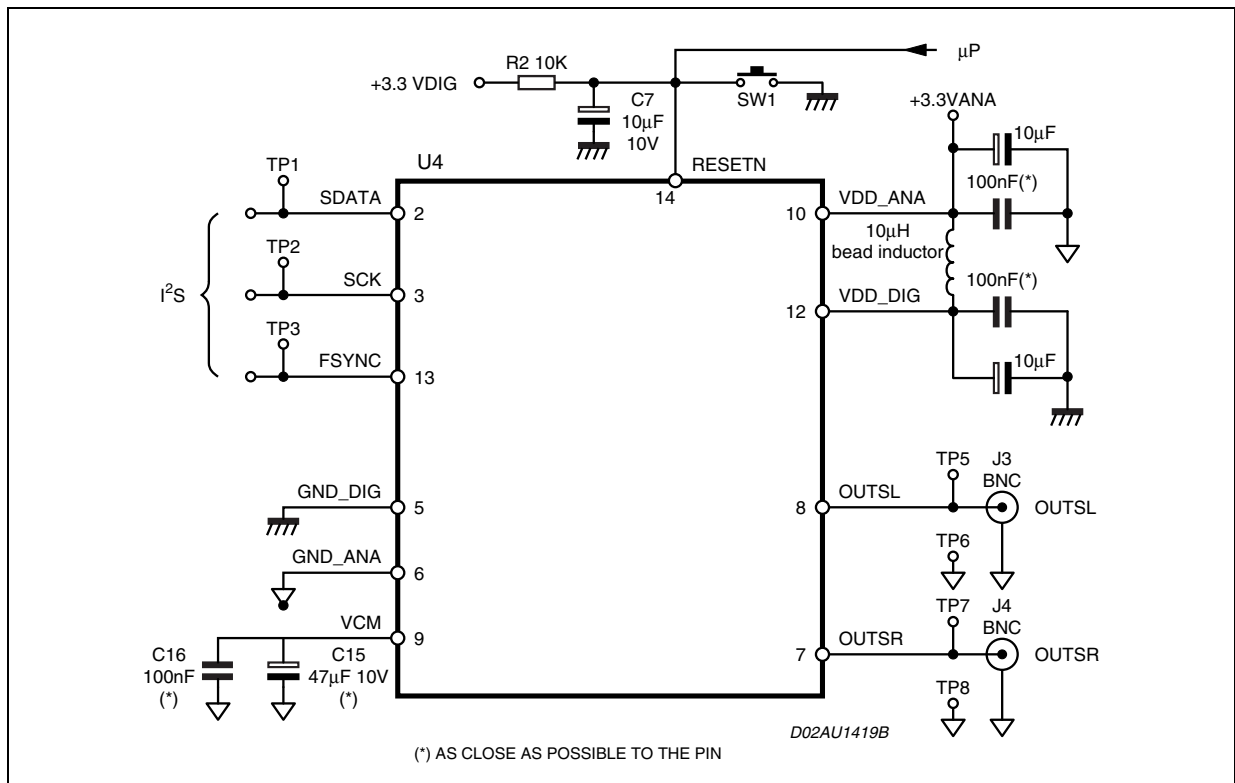
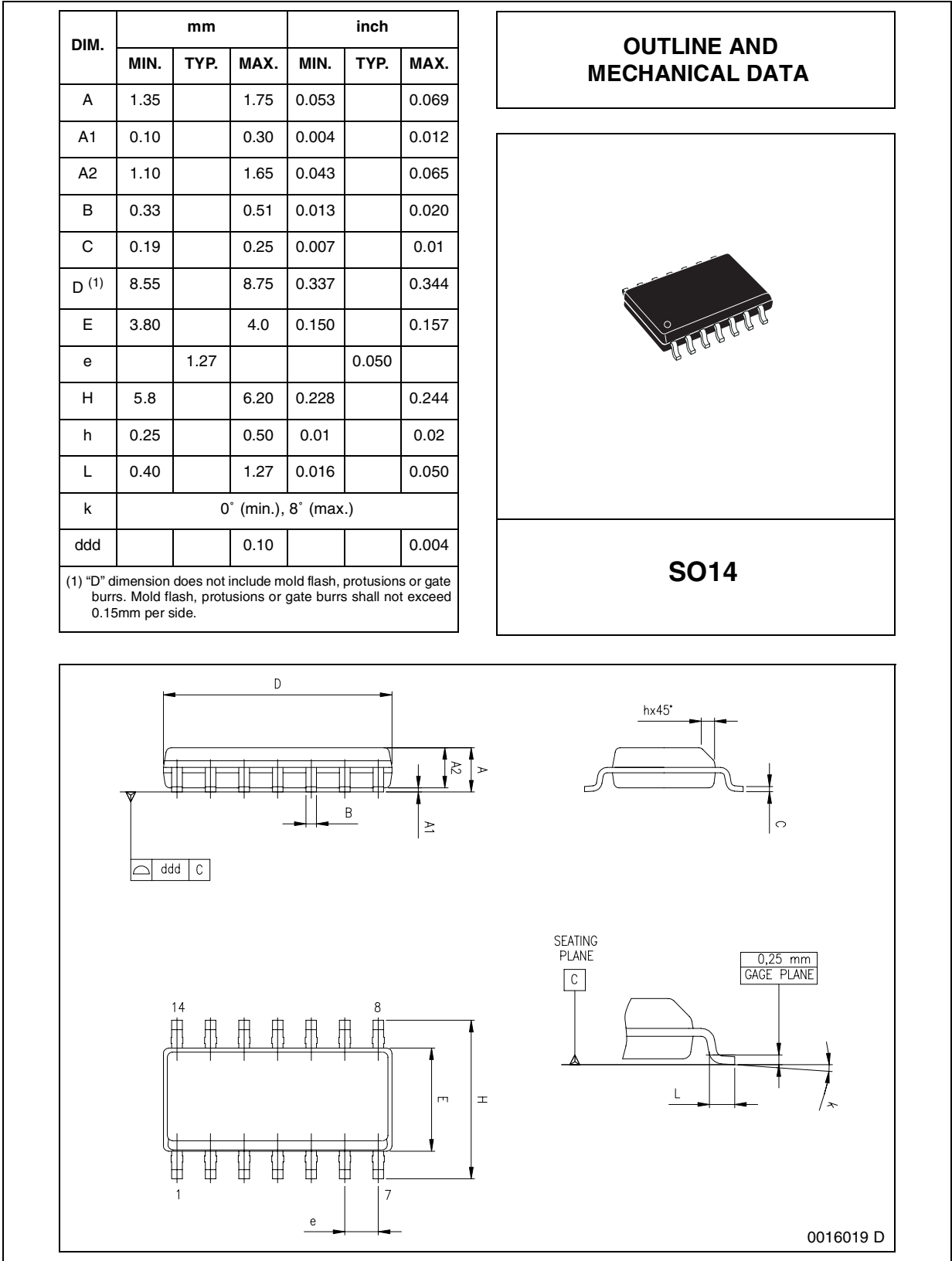

Figure 6. SO14 Mechanical Data & Package Dimensions



REVISION HISTORY

Date	Revision	Changes
December 2003	5	Initial release in EDOCS.
December 2005	6	Update Electrical Characteristics. Add Revision History
February 2006	7	Updated max. value of t_{sckr} and t_{sckt} parameter on page 5/9.

Information furnished is believed to be accurate and reliable. However, STMicroelectronics assumes no responsibility for the consequences of use of such information nor for any infringement of patents or other rights of third parties which may result from its use. No license is granted by implication or otherwise under any patent or patent rights of STMicroelectronics. Specifications mentioned in this publication are subject to change without notice. This publication supersedes and replaces all information previously supplied. STMicroelectronics products are not authorized for use as critical components in life support devices or systems without express written approval of STMicroelectronics.

The ST logo is a registered trademark of STMicroelectronics.
All other names are the property of their respective owners

© 2006 STMicroelectronics - All rights reserved

STMicroelectronics group of companies

Australia - Belgium - Brazil - Canada - China - Czech Republic - Finland - France - Germany - Hong Kong - India - Israel - Italy - Japan -
Malaysia - Malta - Morocco - Singapore - Spain - Sweden - Switzerland - United Kingdom - United States of America

www.st.com

