



STS8DNH3LL

DUAL N-CHANNEL 30V - 0.018 Ω - 8A SO-8 LOW GATE CHARGE STripFET™ III POWER MOSFET

TYPE	V _{DSS}	R _{DS(on)}	I _D
STS8DNH3LL	30 V	<0.022 Ω	8 A

- TYPICAL R_{DS(on)} = 0.018Ω
- OPTIMAL R_{DS(on)} x Q_g TRADE-OFF @ 4.5V
- CONDUCTION LOSSES REDUCED
- SWITCHING LOSSES REDUCED

DESCRIPTION

This application specific MOSFET is the Third generation of STMicroelectronics unique "Single Feature Size™" strip-based process. The resulting transistor shows the best trade-off between on-resistance and gate charge. When used as high and low side in buck regulators, it gives the best performance in terms of both conduction and switching losses. This is extremely important for motherboards where fast switching and high efficiency are of paramount importance.

APPLICATIONS

- SPECIFICALLY DESIGNED AND OPTIMISED FOR HIGH EFFICIENCY CPU CORE DC/DC CONVERTERS FOR MOBILE PC_S

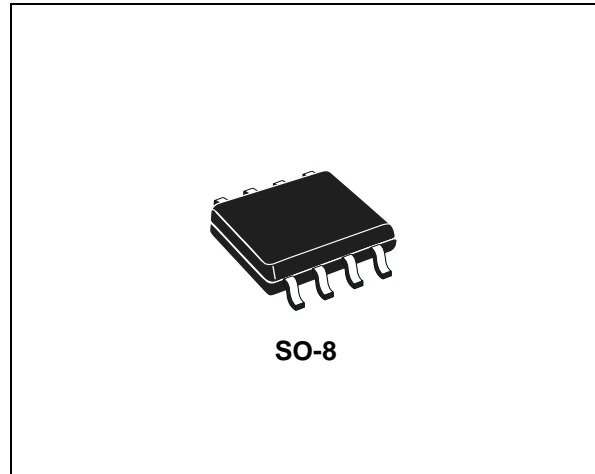

INTERNAL SCHEMATIC DIAGRAM

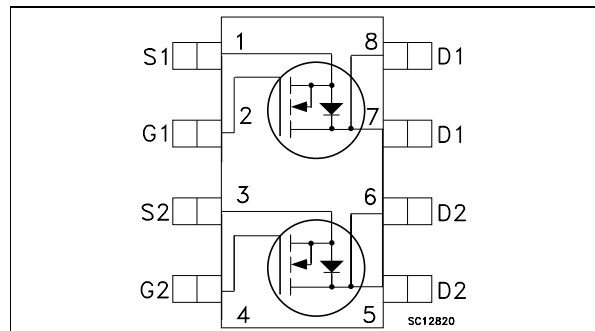

Ordering Information

SALES TYPE	MARKING	PACKAGE	PACKAGING
STS8DNH3LL	S8DNH3LL	SO-8	TAPE & REEL

ABSOLUTE MAXIMUM RATINGS

Symbol	Parameter	Value	Unit
V _{DS}	Drain-source Voltage (V _{GS} = 0)	30	V
V _{DGR}	Drain-gate Voltage (R _{GS} = 20 kΩ)	30	V
V _{GS}	Gate- source Voltage	± 16	V
I _D	Drain Current (continuous) at T _C = 25°C	8	A
I _D	Drain Current (continuous) at T _C = 100°C	5	A
I _{DM} (●)	Drain Current (pulsed)	32	A
P _{tot}	Total Dissipation at T _C = 25°C	2	W

(●) Pulse width limited by safe operating area.

STS8DNH3LL

TAB.1 THERMAL DATA

Rthj-amb T _j T _{stg}	(*)Thermal Resistance Junction-ambient Maximum Operating Junction Temperature Storage Temperature	Max	62.5 150 -55 to 150	°C/W °C °C
--	---	-----	---------------------------	------------------

(*) When mounted on 1 inch² FR-4 board, 2 oz of Cu, t ≤ 10s

ELECTRICAL CHARACTERISTICS (T_j = 25 °C unless otherwise specified)

TAB.2 OFF

Symbol	Parameter	Test Conditions	Min.	Typ.	Max.	Unit
V _{(BR)DSS}	Drain-source Breakdown Voltage	I _D = 250 μA, V _{GS} = 0	30			V
I _{DSS}	Zero Gate Voltage Drain Current (V _{GS} = 0)	V _{DS} = Max Rating V _{DS} = Max Rating T _C = 125°C			1 10	μA μA
I _{GSS}	Gate-body Leakage Current (V _{DS} = 0)	V _{GS} = ± 16 V			±100	nA

TAB.3 ON (*)

Symbol	Parameter	Test Conditions	Min.	Typ.	Max.	Unit
V _{GS(th)}	Gate Threshold Voltage	V _{DS} = V _{GS} I _D = 250 μA	1			V
R _{DS(on)}	Static Drain-source On Resistance	V _{GS} = 10 V I _D = 4 A V _{GS} = 4.5 V I _D = 4 A		0.018 0.020	0.022 0.025	Ω Ω

TAB.4 DYNAMIC

Symbol	Parameter	Test Conditions	Min.	Typ.	Max.	Unit
g _{fs} (*)	Forward Transconductance	V _{DS} =15 V I _D = 4 A		8.5		S
C _{iss} C _{oss} C _{rss}	Input Capacitance Output Capacitance Reverse Transfer Capacitance	V _{DS} = 25V, f = 1 MHz, V _{GS} = 0		857 147 20		pF pF pF

ELECTRICAL CHARACTERISTICS (continued)

TAB.5 SWITCHING ON

Symbol	Parameter	Test Conditions	Min.	Typ.	Max.	Unit
$t_{d(on)}$ t_r	Turn-on Delay Time Rise Time	$V_{DD} = 15\text{ V}$ $I_D = 4\text{ A}$ $R_G = 4.7\ \Omega$ $V_{GS} = 10\text{ V}$ (Resistive Load, Figure 1)		12 14.5		ns ns
Q_g Q_{gs} Q_{gd}	Total Gate Charge Gate-Source Charge Gate-Drain Charge	$V_{DD} = 15\text{ V}$ $I_D = 8\text{ A}$ $V_{GS} = 4.5\text{ V}$ (see test circuit, Figure 2)		7.0 2.5 2.3	10	nC nC nC

TAB.6 SWITCHING OFF

Symbol	Parameter	Test Conditions	Min.	Typ.	Max.	Unit
$t_{d(off)}$ t_f	Turn-off Delay Time Fall Time	$V_{DD} = 15\text{ V}$ $I_D = 4\text{ A}$ $R_G = 4.7\ \Omega$, $V_{GS} = 10\text{ V}$ (Resistive Load, Figure 1)		23 8		ns ns

TAB.7 SOURCE DRAIN DIODE

Symbol	Parameter	Test Conditions	Min.	Typ.	Max.	Unit
I_{SD} $I_{SDM} (\bullet)$	Source-drain Current Source-drain Current (pulsed)				8 32	A A
$V_{SD} (*)$	Forward On Voltage	$I_{SD} = 4\text{ A}$ $V_{GS} = 0$			1.5	V
t_{rr} Q_{rr} I_{RRM}	Reverse Recovery Time Reverse Recovery Charge Reverse Recovery Current	$I_{SD} = 8\text{ A}$ $di/dt = 100\text{ A}/\mu\text{s}$ $V_{DD} = 15\text{ V}$ $T_j = 150^\circ\text{C}$ (see test circuit, Figure 3)		15 5.7 0.76		ns nC A

(*)Pulsed: Pulse duration = 300 μs , duty cycle 1.5 %.

(\bullet)Pulse width limited by safe operating area.

Safe Operating Area

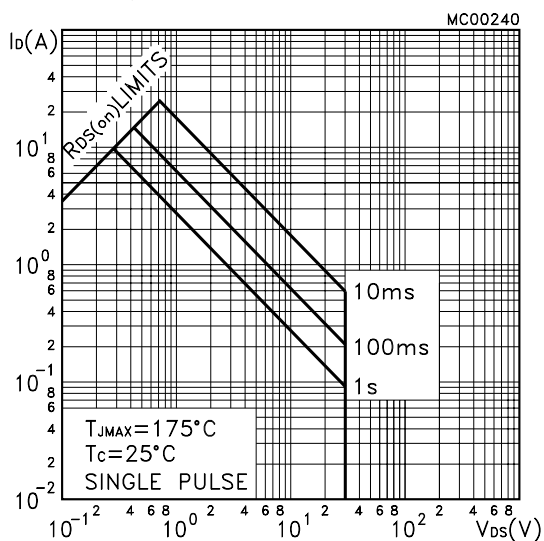

Thermal Impedance

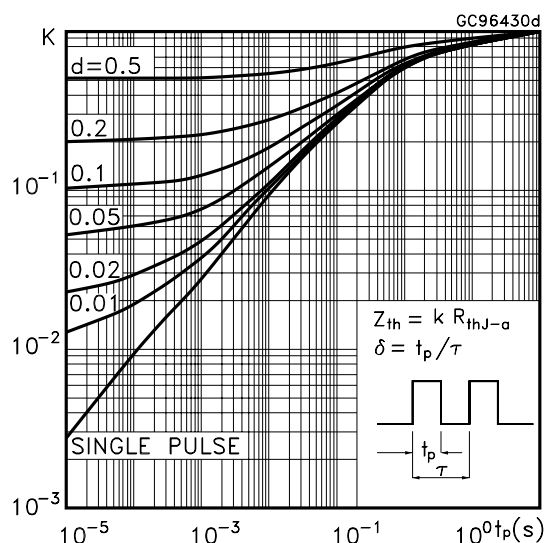

STS8DNH3LL

Output Characteristics

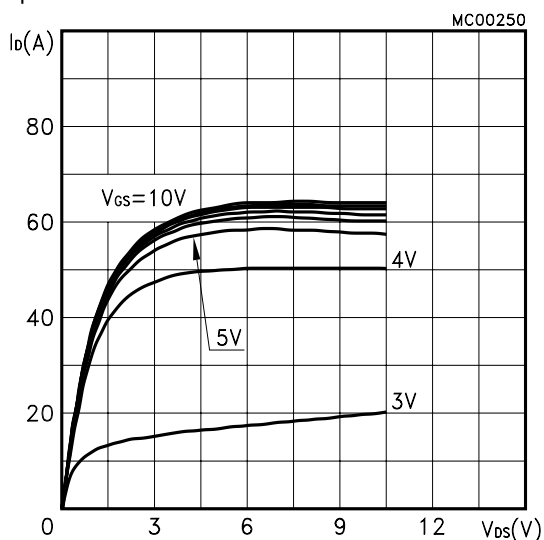

Transfer Characteristics

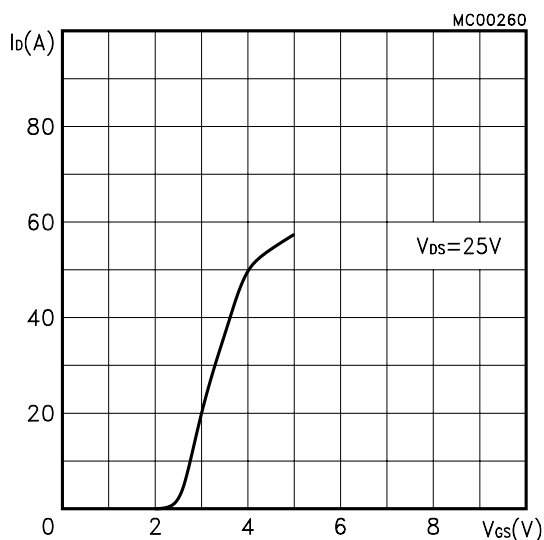

Transconductance

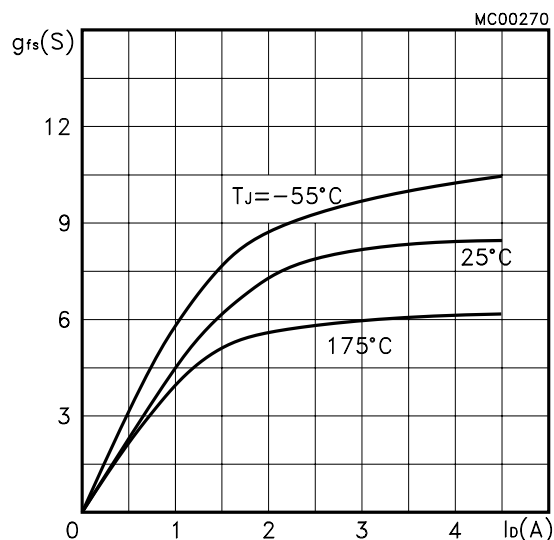

Static Drain-source On Resistance

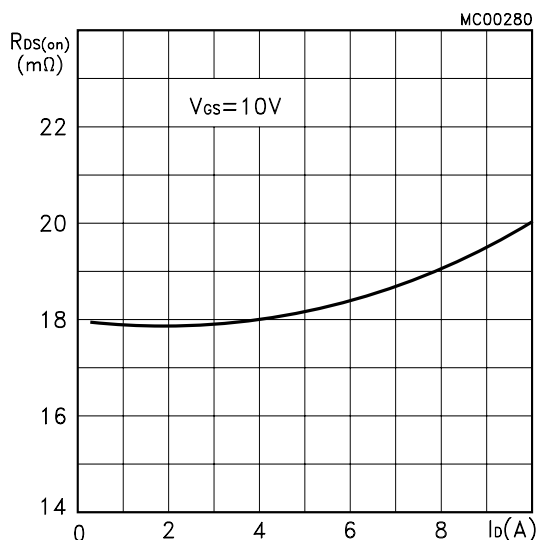

Gate Charge vs Gate-source Voltage

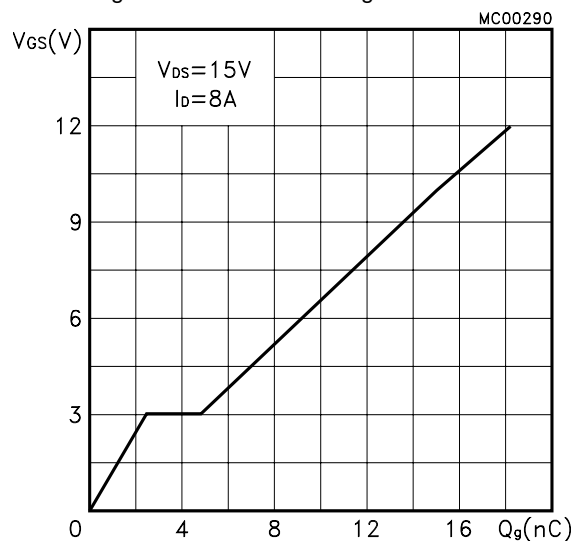

Capacitance Variations

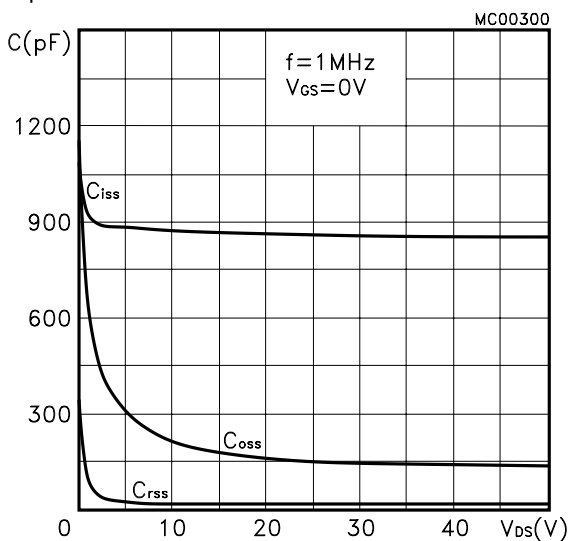

Normalized Gate Threshold Voltage vs Temperature

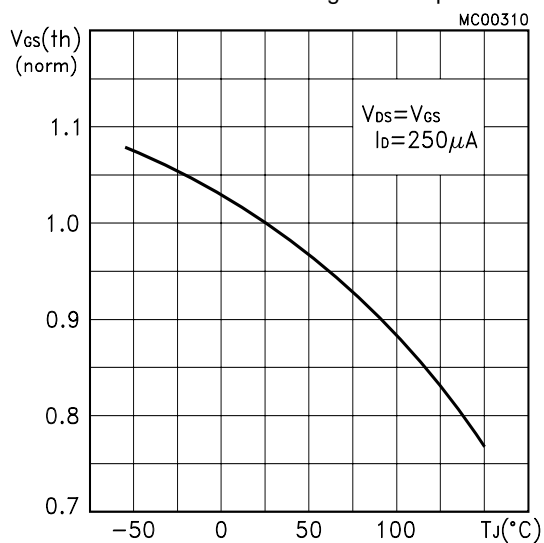

Normalized on Resistance vs Temperature

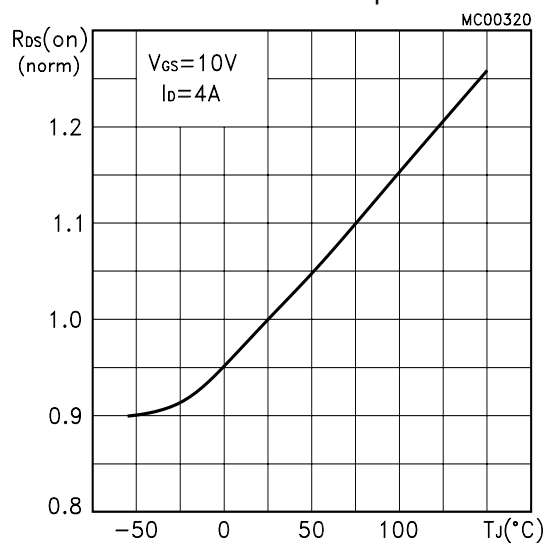

Source-drain Diode Forward Characteristics

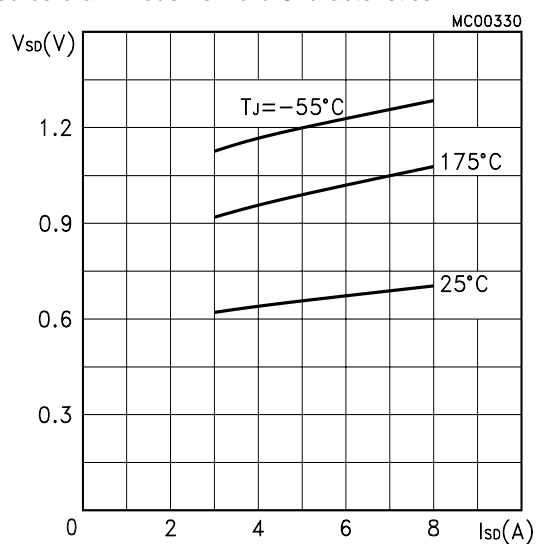

Normalized Breakdown Voltage Temperature.

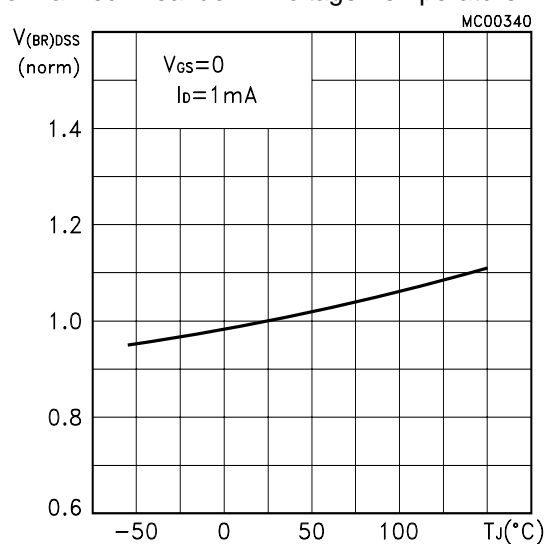

Fig. 1: Switching Times Test Circuits For Resistive Load

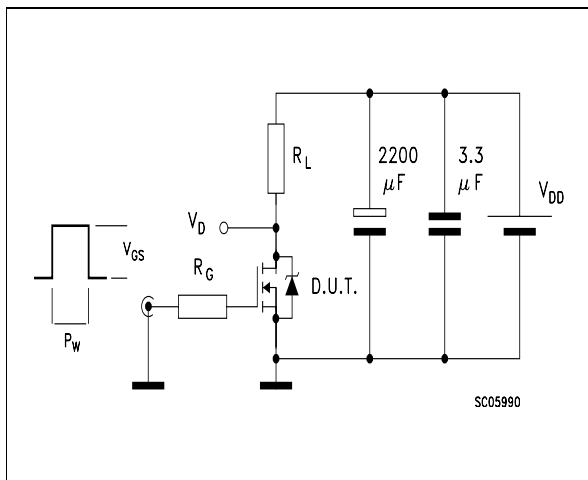

Fig. 2: Gate Charge test Circuit

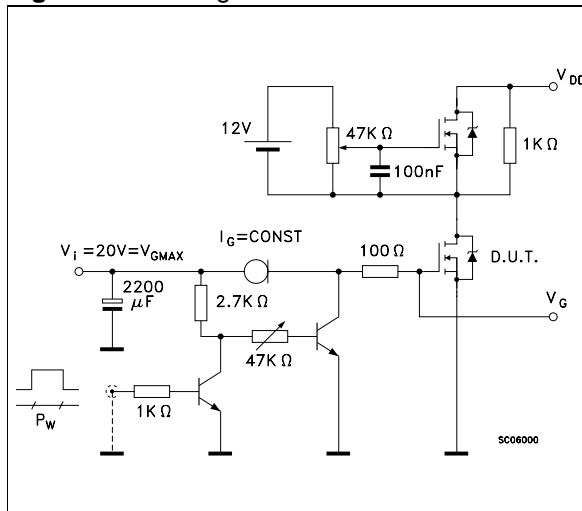
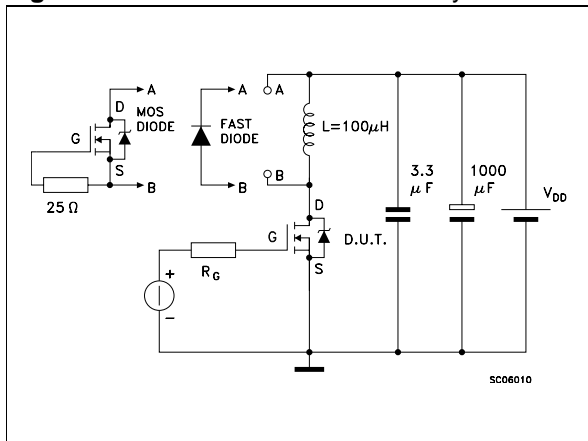
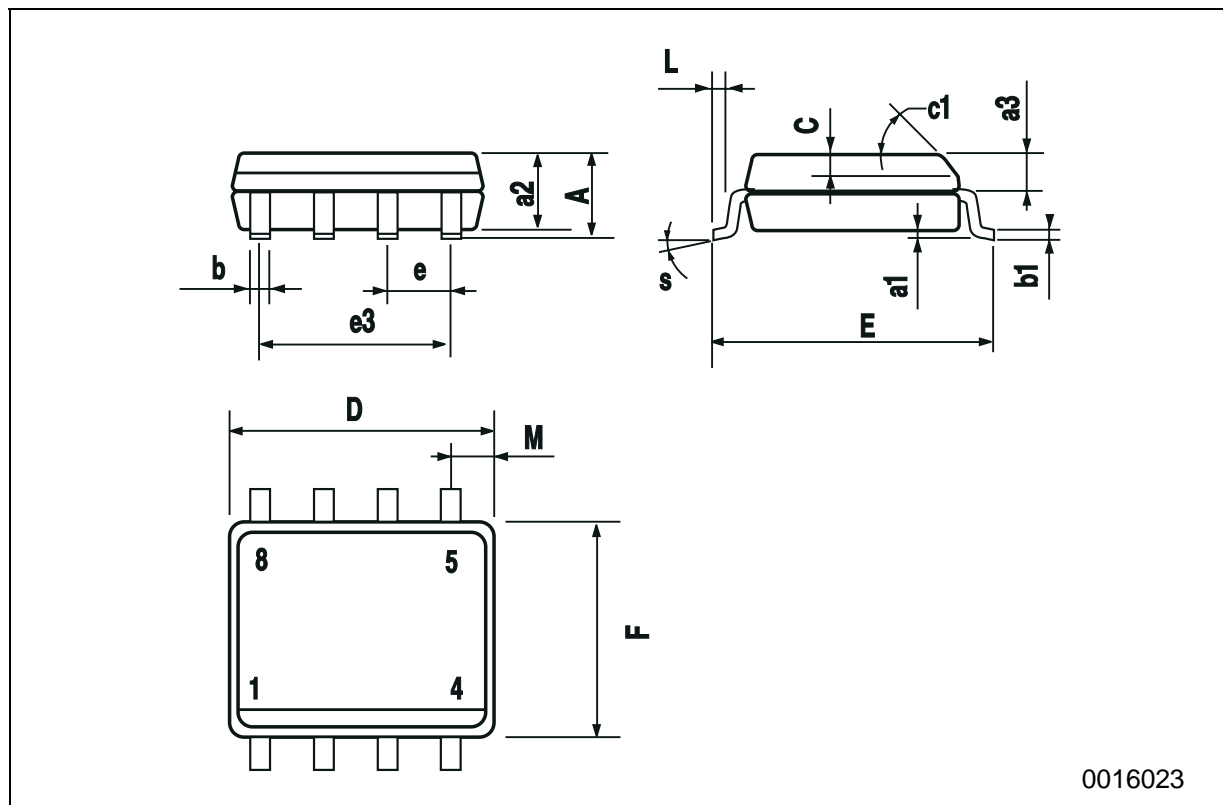

Fig. 3: Test Circuit For Diode Recovery Behaviour



SO-8 MECHANICAL DATA

DIM.	mm			inch		
	MIN.	TYP.	MAX.	MIN.	TYP.	MAX.
A			1.75			0.068
a1	0.1		0.25	0.003		0.009
a2			1.65			0.064
a3	0.65		0.85	0.025		0.033
b	0.35		0.48	0.013		0.018
b1	0.19		0.25	0.007		0.010
C	0.25		0.5	0.010		0.019
c1	45 (typ.)					
D	4.8		5.0	0.188		0.196
E	5.8		6.2	0.228		0.244
e		1.27			0.050	
e3		3.81			0.150	
F	3.8		4.0	0.14		0.157
L	0.4		1.27	0.015		0.050
M			0.6			0.023
S	8 (max.)					



Revision History

Date	Revision	Description of Changes
Tuesday 15 June 2004	0.2	FIRST ISSUE

Information furnished is believed to be accurate and reliable. However, STMicroelectronics assumes no responsibility for the consequences of use of such information nor for any infringement of patents or other rights of third parties which may result from its use. No license is granted by implication or otherwise under any patent or patent rights of STMicroelectronics. Specifications mentioned in this publication are subject to change without notice. This publication supersedes and replaces all information previously supplied. STMicroelectronics products are not authorized for use as critical components in life support devices or systems without express written approval of STMicroelectronics.

The ST logo is registered trademark of STMicroelectronics
All other names are the property of their respective owners.

© 2004 STMicroelectronics - All Rights Reserved

STMicroelectronics GROUP OF COMPANIES

Australia - Belgium - Brazil - Canada - China - Czech Republic - Finland - France - Germany - Hong Kong - India - Israel - Italy - Japan -
Malaysia - Malta - Morocco - Singapore - Spain - Sweden - Switzerland - United Kingdom - United States.

www.st.com