



STS5PF20V

P-CHANNEL 20V - 0.065Ω - 5A SO-8
2.5V-DRIVE STripFET™ II POWER MOSFET

TYPE	V _{DSS}	R _{DS(on)}	I _D
STS5PF20V	20 V	< 0.080 Ω (@4.5V) < 0.10 Ω (@2.5V)	5 A

- TYPICAL R_{DS(on)} = 0.065Ω (@4.5V)
- TYPICAL R_{DS(on)} = 0.085Ω (@2.5V)
- ULTRA LOW THRESHOLD GATE DRIVE (2.5V)
- STANDARD OUTLINE FOR EASY AUTOMATED SURFACE MOUNT ASSEMBLY

DESCRIPTION

This Power MOSFET is the latest development of STMicroelectronics unique "Single Feature Size™" strip-based process. The resulting transistor shows extremely extremely low on-resistance when driven at 2.5V.

APPLICATIONS

- POWER MANAGEMENT IN CELLULAR PHONES
- DC-DC CONVERTERS
- BATTERY MANAGEMENT IN NOMADIC EQUIPMENT

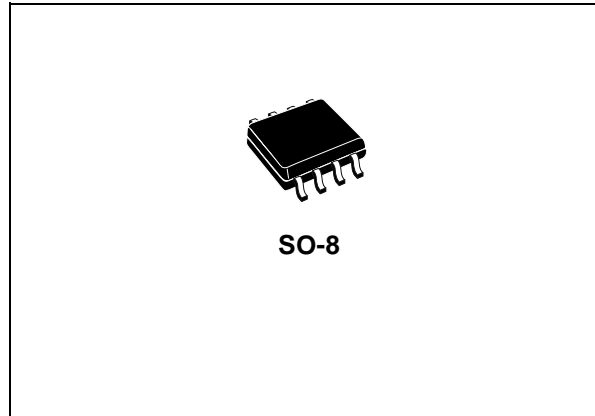

SO-8

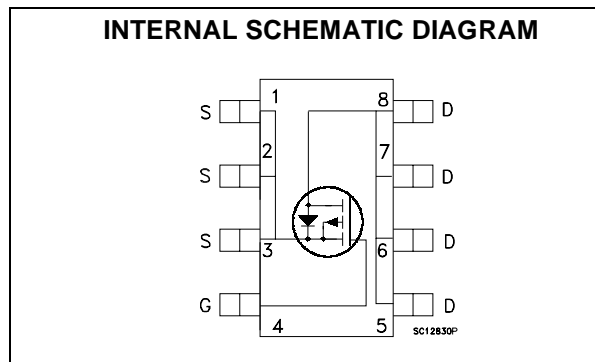

ORDER CODES

PART NUMBER	MARKING	PACKAGE	PACKAGING
STS5PF20V	S5PF20V	SO-8	TAPE & REEL

STS5PF20V

ABSOLUTE MAXIMUM RATINGS

Symbol	Parameter	Value	Unit
V _{DS}	Drain-source Voltage (V _{GS} = 0)	20	V
V _{DGR}	Drain-gate Voltage (R _{GS} = 20 kΩ)	20	V
V _{GS}	Gate- source Voltage	± 8	V
I _D	Drain Current (continuous) at T _C = 25°C	5	A
I _D	Drain Current (continuous) at T _C = 100°C	3.1	A
I _{DM} (•)	Drain Current (pulsed)	20	A
P _{TOT}	Total Dissipation at T _C = 25°C	2.5	W

(•) Pulse width limited by safe operating area

Note: For the P-CHANNEL MOSFET actual polarity of voltages and current has to be reversed

THERMAL DATA

R _{thj-amb}	Thermal Resistance Junction-ambient Max	50	°C/W
T _j	Max. Operating Junction Temperature	-55 to 150	°C
T _{stg}	Storage Temperature	-55 to 150	°C

ELECTRICAL CHARACTERISTICS (T_J = 25 °C UNLESS OTHERWISE SPECIFIED)

OFF

Symbol	Parameter	Test Conditions	Min.	Typ.	Max.	Unit
V _{(BR)DSS}	Drain-source Breakdown Voltage	I _D = 250 μA, V _{GS} = 0	20			V
I _{DSS}	Zero Gate Voltage Drain Current (V _{GS} = 0)	V _{DS} = Max Rating V _{DS} = Max Rating, T _C = 125 °C			1 10	μA μA
I _{GSS}	Gate-body Leakage Current (V _{DS} = 0)	V _{GS} = ± 8V			±100	nA

ON (1)

Symbol	Parameter	Test Conditions	Min.	Typ.	Max.	Unit
V _{GS(th)}	Gate Threshold Voltage	V _{DS} = V _{GS} , I _D = 250μA	0.45			V
R _{DS(on)}	Static Drain-source On Resistance	V _{GS} = 4.5V, I _D = 2.5 A V _{GS} = 2.5V, I _D = 2.5 A		0.065 0.085	0.080 0.10	Ω Ω

DYNAMIC

Symbol	Parameter	Test Conditions	Min.	Typ.	Max.	Unit
g _{fs} (1)	Forward Transconductance	V _{DS} = 15 V, I _D = 2.5 A		6.6		S
C _{iss}	Input Capacitance	V _{DS} = 15 V, f = 1 MHz, V _{GS} = 0		412		pF
C _{oss}	Output Capacitance			179		pF
C _{rss}	Reverse Transfer Capacitance			42.5		pF

ELECTRICAL CHARACTERISTICS (CONTINUED)
SWITCHING ON

Symbol	Parameter	Test Conditions	Min.	Typ.	Max.	Unit
$t_{d(on)}$	Turn-on Delay Time	$V_{DD} = 10\text{ V}$, $I_D = 2.5\text{ A}$		11		ns
t_r	Rise Time	$R_G = 4.7\Omega$, $V_{GS} = 2.5\text{ V}$ (see test circuit, Figure 1)		47		ns
Q_g Q_{gs} Q_{gd}	Total Gate Charge Gate-Source Charge Gate-Drain Charge	$V_{DD} = 10\text{ V}$, $I_D = 5\text{ A}$, $V_{GS} = 2.5\text{ V}$ (see test circuit, Figure 2)		4.5 0.73 1.75	6	nC nC nC

SWITCHING OFF

Symbol	Parameter	Test Conditions	Min.	Typ.	Max.	Unit
$t_{d(off)}$	Turn-off-Delay Time	$V_{DD} = 10\text{ V}$, $I_D = 2.5\text{ A}$,		39		ns
t_f	Fall Time	$R_G = 4.7\Omega$, $V_{GS} = 2.5\text{ V}$ (see test circuit, Figure 1)		20		ns

SOURCE DRAIN DIODE

Symbol	Parameter	Test Conditions	Min.	Typ.	Max.	Unit
I_{SD}	Source-drain Current				5	A
I_{SDM}	Source-drain Current (pulsed)				20	A
$V_{SD(1)}$	Forward On Voltage	$I_{SD} = 5\text{ A}$, $V_{GS} = 0$			1.2	V
t_{rr} Q_{rr} I_{RRM}	Reverse Recovery Time Reverse Recovery Charge Reverse Recovery Current	$I_{SD} = 5\text{ A}$, $di/dt = 100\text{ A}/\mu\text{s}$, $V_{DD} = 16\text{ V}$, $T_j = 150^\circ\text{C}$ (see test circuit, Figure 3)		32 12.8 0.8		ns nC A

Note: 1. Pulsed: Pulse duration = 300 μs , duty cycle 1.5 %.

Safe Operating Area

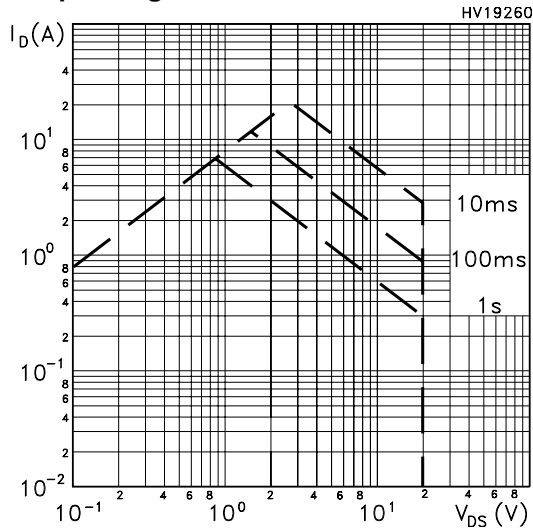

Thermal Impedance

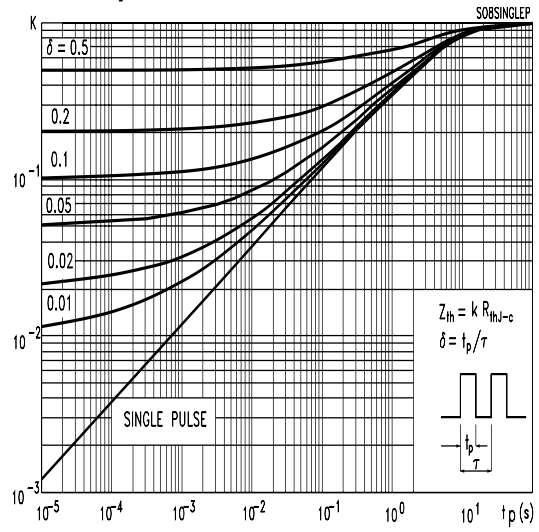

Output Characteristics

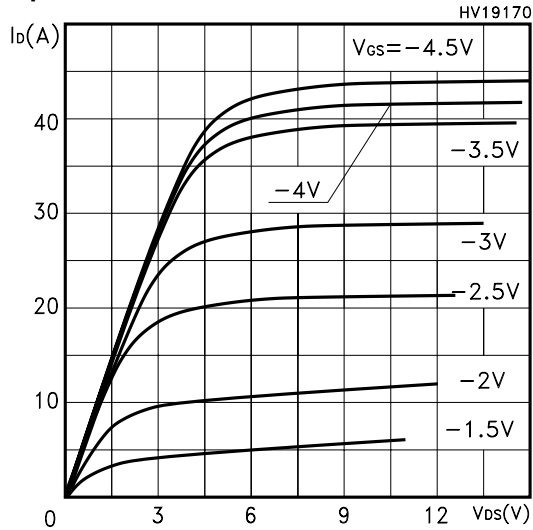

Transfer Characteristics

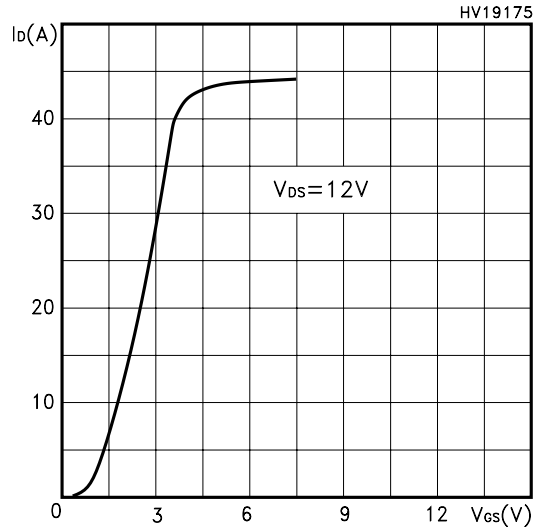

Transconductance

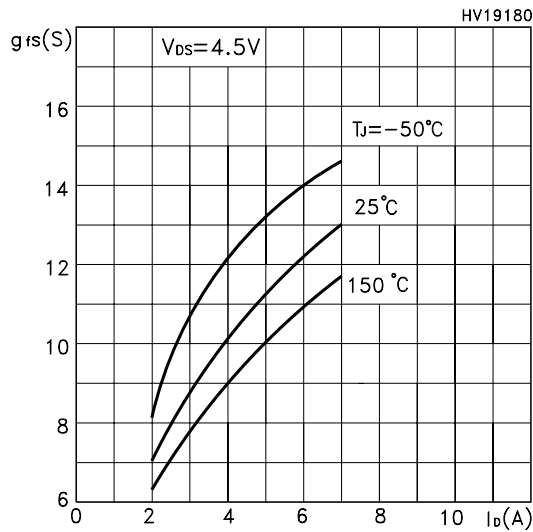

Static Drain-source On Resistance

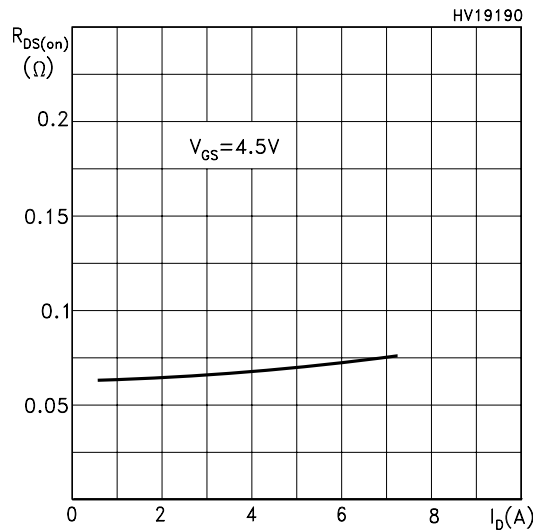

Gate Charge vs Gate-source Voltage

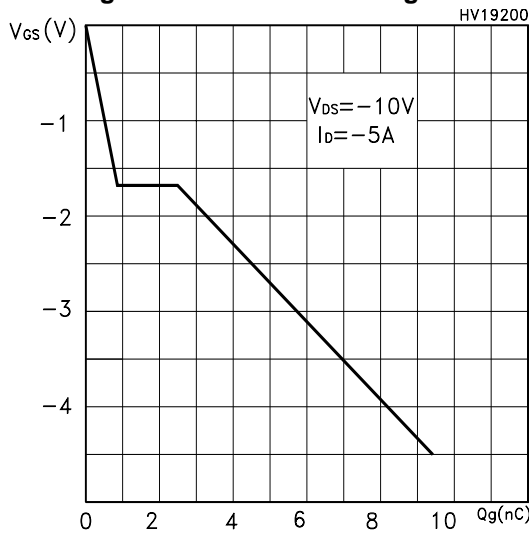

Normalized Gate Threshold Voltage vs Temp.

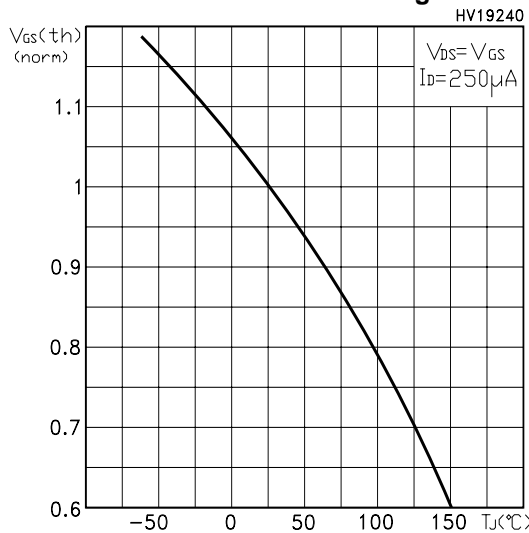

Capacitance Variations

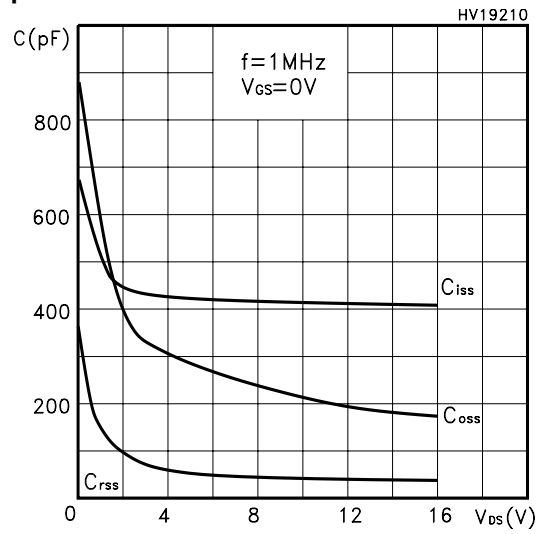

Normalized On Resistance vs Temperature

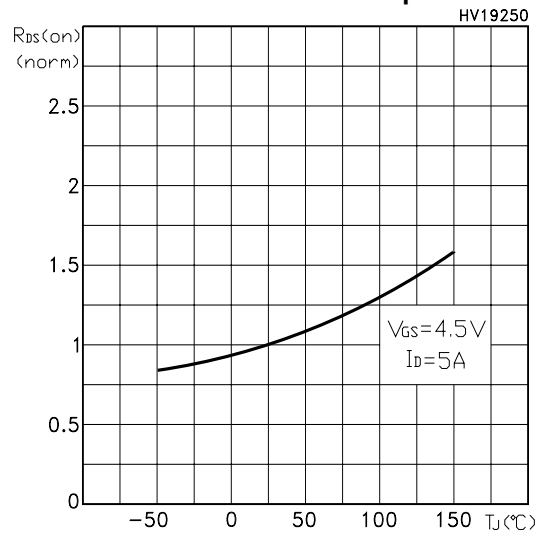

Source-drain Diode Forward Characteristics

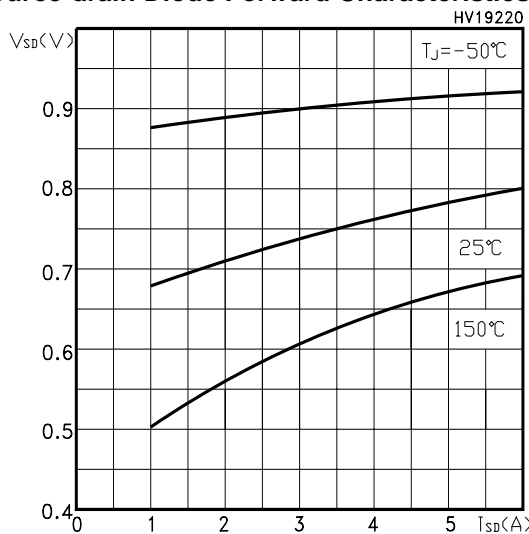

Fig. 1: Switching Times Test Circuit For Resistive Load

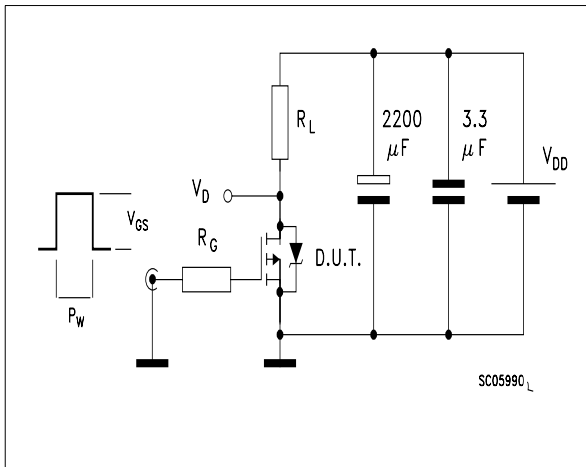

Fig. 2: Gate Charge test Circuit

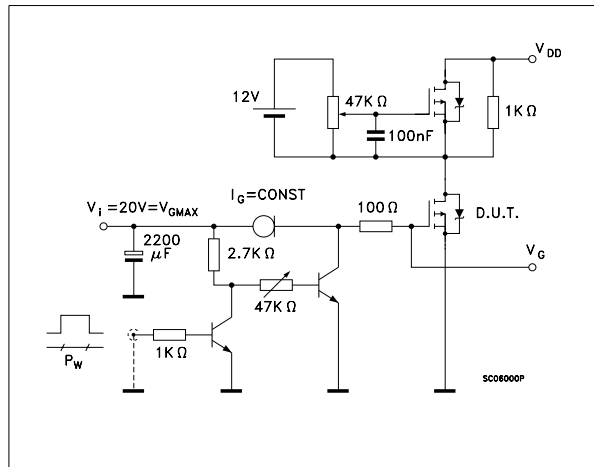
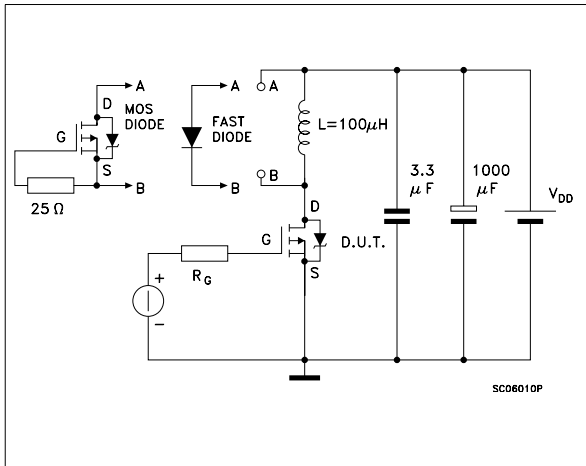
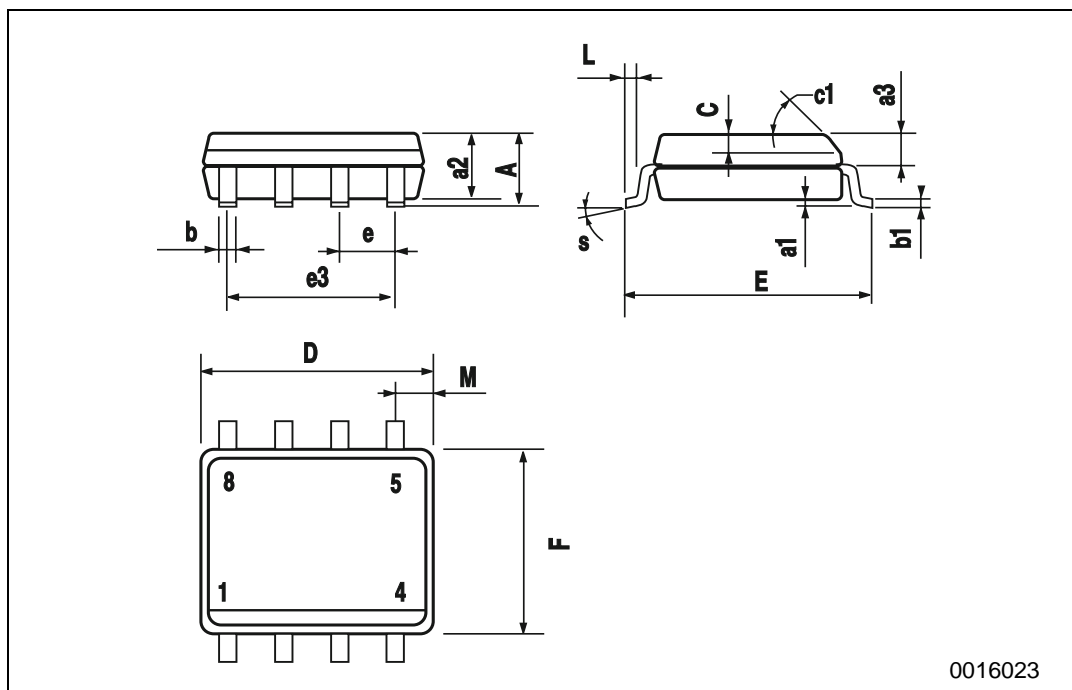

Fig. 3: Test Circuit For Diode Recovery Behaviour



SO-8 MECHANICAL DATA

DIM.	mm			inch		
	MIN.	TYP.	MAX.	MIN.	TYP.	MAX.
A			1.75			0.068
a1	0.1		0.25	0.003		0.009
a2			1.65			0.064
a3	0.65		0.85	0.025		0.033
b	0.35		0.48	0.013		0.018
b1	0.19		0.25	0.007		0.010
C	0.25		0.5	0.010		0.019
c1	45 (typ.)					
D	4.8		5.0	0.188		0.196
E	5.8		6.2	0.228		0.244
e		1.27			0.050	
e3		3.81			0.150	
F	3.8		4.0	0.14		0.157
L	0.4		1.27	0.015		0.050
M			0.6			0.023
S	8 (max.)					



Information furnished is believed to be accurate and reliable. However, STMicroelectronics assumes no responsibility for the consequences of use of such information nor for any infringement of patents or other rights of third parties which may result from its use. No license is granted by implication or otherwise under any patent or patent rights of STMicroelectronics. Specifications mentioned in this publication are subject to change without notice. This publication supersedes and replaces all information previously supplied. STMicroelectronics products are not authorized for use as critical components in life support devices or systems without express written approval of STMicroelectronics.

The ST logo is a registered trademark of STMicroelectronics
All other names are the property of their respective owners

© 2004 STMicroelectronics - All Rights Reserved
STMicroelectronics GROUP OF COMPANIES

Australia - Belgium - Brazil - Canada - China - Czech Republic - Finland - France - Germany - Hong Kong - India - Israel - Italy - Japan -
Malaysia - Malta - Morocco - Singapore - Spain - Sweden - Switzerland - United Kingdom - United States.

<http://www.st.com>