



STB11NK40Z - STP11NK40ZFP STP11NK40Z

N-CHANNEL 400V - 0.49Ω - 9A - TO220-TO220FP-D²PAK
Zener-Protected SuperMESH™ MOSFET

General features

Type	V _{DSS}	R _{DS(on)}	I _D	P _w
STB11NK40Z	400 V	<0.55 Ω	9 A	110 W
STP11NK40Z	400 V	<0.55 Ω	9 A	110 W
STP11NK40ZFP	400 V	<0.55 Ω	9 A	30 W

- EXTREMELY HIGH dv/dt CAPABILITY
- 100% AVALANCHE TESTED
- GATE CHARGE MINIMIZED
- VERY LOW INTRINSIC CAPACITANCES
- VERY GOOD MANUFACTURING REPEATABILITY

Description

The SuperMESH™ series is obtained through an extreme optimization of ST's well established strip-based PowerMESH™ layout. In addition to pushing on-resistance significantly down, special care is taken to ensure a very good dv/dt capability for the most demanding applications.

Applications

- HIGH CURRENT, HIGH SPEED SWITCHING
- IDEAL FOR OFF-LINE POWER SUPPLIES, ADAPTOR AND PFC
- LIGHTING

Order codes

Sales Type	Marking	Package	Packaging
STB11NK40ZT4	B11NK40Z	D ² PAK	TAPE & REEL
STP11NK40Z	P11NK40Z	TO-220	TUBE
STP11NK40ZFP	P11NK40ZFP	TO-220FP	TUBE

Package

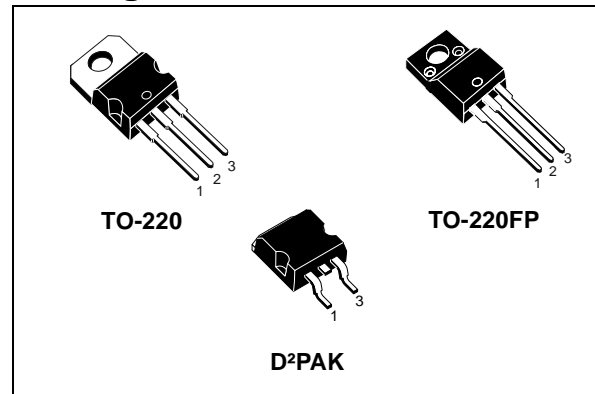

Internal schematic diagram

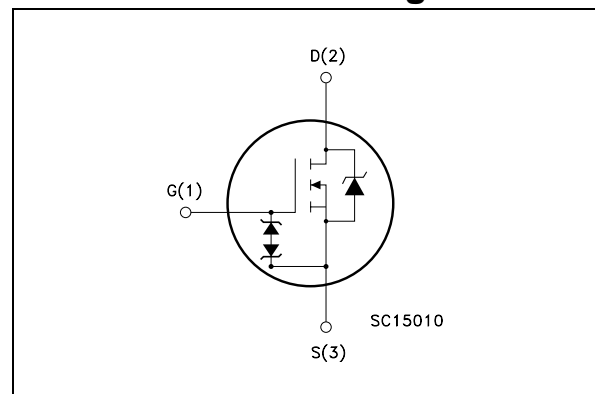

1 Electrical ratings

Table 1. Absolute maximum ratings

Symbol	Parameter	Value		Unit
		TO-220/D ² PAK	TO-220FP	
V _{DS}	Drain-Source Voltage (V _{GS} = 0)	400		V
V _{DGR}	Drain-gate Voltage (R _{GS} = 20kΩ)	400		V
V _{GS}	Gate-Source Voltage	± 30		V
I _D	Drain Current (continuous) at T _C = 25°C	9	9 (Note 3)	A
I _D	Drain Current (continuous) at T _C = 100°C	5.67	5.67 (Note 3)	A
I _{DM} Note 2	Drain Current (pulsed)	36	36 (Note 3)	A
P _{TOT}	Total Dissipation at T _C = 25°C	110	30	W
	Derating Factor	0.88	0.24	W/°C
Vesd(G-S)	G-S ESD (HBM C=100pF, R=1.5kΩ)	3500		V
dv/dt Note 1	Peak Diode Recovery voltage slope	4.5		V/ns
V _{ISO}	Insulation Withstand Voltage (DC)	--	2500	V
T _j T _{stg}	Operating Junction Temperature Storage Temperature	-55 to 150		°C

Table 2. Thermal data

		TO-220/D ² PAK	TO-220FP	Unit
R _{thj-case}	Thermal Resistance Junction-case Max	1.14	4.2	°C/W
R _{thj-amb}	Thermal Resistance Junction-amb Max	62.5		°C/W
T _l	Maximum Lead Temperature For Soldering Purpose	300		°C

Table 3. Avalanche characteristics

Symbol	Parameter	Max Value	Unit
I _{AR}	Avalanche Current, repetitive or Not-Repetitive (pulse width limited by T _j max)	9	A
E _{AS}	Single Pulse Avalanche Energy (starting T _j =25°C, I _D =I _{AR} , V _{DD} = 50V)	190	mJ

2 Electrical characteristics

($T_{CASE} = 25\text{ °C}$ unless otherwise specified)

Table 4. On/off states

Symbol	Parameter	Test Conditions	Min.	Typ.	Max.	Unit
$V_{(BR)DSS}$	Drain-Source Breakdown Voltage	$I_D = 1\text{ mA}, V_{GS} = 0$	400			V
I_{DSS}	Zero Gate Voltage Drain Current ($V_{GS} = 0$)	$V_{DS} = \text{Max Rating},$ $V_{DS} = \text{Max Rating}, T_c = 125\text{ °C}$			1 50	μA μA
I_{GSS}	Gate Body Leakage Current ($V_{DS} = 0$)	$V_{GS} = \pm 20\text{ V}, V_{DS} = 0$			± 10	μA
$V_{GS(th)}$	Gate Threshold Voltage	$V_{DS} = V_{GS}, I_D = 100\ \mu\text{A}$	3	3.75	4.5	V
$R_{DS(on)}$	Static Drain-Source On Resistance	$V_{GS} = 10\ \text{V}, I_D = 4.5\ \text{A}$		0.49	0.55	Ω

Table 5. Dynamic

Symbol	Parameter	Test Conditions	Min.	Typ.	Max.	Unit
g_{fs} <i>Note 4</i>	Forward Transconductance	$V_{DS} = 15\text{ V}, I_D = 4.5\text{ A}$		5.8		S
C_{iss}	Input Capacitance	$V_{DS} = 25\text{ V}, f = 1\ \text{MHz}, V_{GS} = 0$		930		pF
C_{oss}	Output Capacitance			140		pF
C_{rss}	Reverse Transfer Capacitance			30		pF
$C_{oss\ eq.}$ <i>Note 5</i>	Equivalent Output Capacitance	$V_{GS} = 0, V_{DS} = 0\text{ V to } 400\text{ V}$		78		pF
Q_g	Total Gate Charge	$V_{DD} = 320\text{ V}, I_D = 9\text{ A}$		32	45	nC
Q_{gs}	Gate-Source Charge	$V_{GS} = 10\text{ V}$		6		nC
Q_{gd}	Gate-Drain Charge	(see Figure 17)		18.5		nC

Table 6. Switching times

Symbol	Parameter	Test Conditions	Min.	Typ.	Max.	Unit
$t_{d(on)}$ t_r	Turn-on Delay Time Rise Time	$V_{DD} = 200\ \text{V}, I_D = 4.5\ \text{A},$ $R_G = 4.7\ \Omega, V_{GS} = 10\ \text{V}$ (see Figure 18)		20 20		ns ns
$t_{d(off)}$ t_f	Turn-off Delay Time Fall Time	$V_{DD} = 200\ \text{V}, I_D = 4.5\ \text{A},$ $R_G = 4.7\ \Omega, V_{GS} = 10\ \text{V}$ (see Figure 18)		40 18		ns ns
$t_{r(Voff)}$ t_f t_c	Off-voltage Rise Time Fall Time Cross-over Time	$V_{DD} = 320\ \text{V}, I_D = 9\ \text{A},$ $R_G = 4.7\ \Omega, V_{GS} = 10\ \text{V}$ (see Figure 18)		15 17 30		ns ns ns

Table 7. Source drain diode

Symbol	Parameter	Test Conditions	Min.	Typ.	Max.	Unit
I_{SD}	Source-drain Current				9	A
I_{SDM} <i>Note 2</i>	Source-drain Current (pulsed)				36	A
V_{SD} <i>Note 4</i>	Forward on Voltage	$I_{SD}=9A, V_{GS}=0$			1.6	V
t_{rr}	Reverse Recovery Time	$I_{SD}=9A, di/dt = 100A/\mu s,$ $V_{DD}=45 V, T_j=150^\circ C$		225		ns
Q_{rr}	Reverse Recovery Charge			1.6		μC
I_{RRM}	Reverse Recovery Current			14		A

Table 8. Gate-source zener diode

Symbol	Parameter	Test Conditions	Min.	Typ.	Max.	Unit
BV_{GSO} <i>Note 6</i>	Gate-Source Breakdown Voltage	$I_{GS}=\pm 1mA$ (Open Drain)	30			V

(1) $I_{SD} \leq 9A, di/dt \leq 200A/\mu s, V_{DD} \leq V_{(BR)DSS}, T_j \leq T_{JMAX}$

(2) Pulse width limited by safe operating area

(3) Limited only by maximum temperature allowed

(4) Pulsed: pulse duration = 300 μs , duty cycle 1.5%

(5) $C_{OSS\ eq}$ is defined as a constant equivalent capacitance giving the same charging time as C_{OSS} when V_{DS} increases from 0 to 80%

(6) The built-in back-to-back Zener diodes have specifically been designed to enhance not only the device's ESD capability, but also to make them safely absorb possible voltage transients that may occasionally be applied from gate to source. In this respect the Zener voltage is appropriate to achieve an efficient and cost-effective intervention to protect the device's integrity. These integrated Zener diodes thus avoid the usage of external components.

2.1 Electrical Characteristics (curves)

Figure 1. Safe Operating Area for TO-220/D²PAK

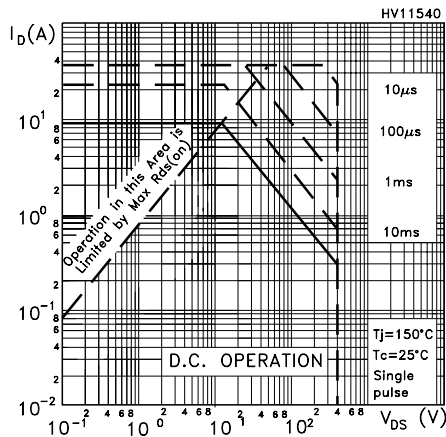

Figure 2. Thermal Impedance for TO-220/D²PAK

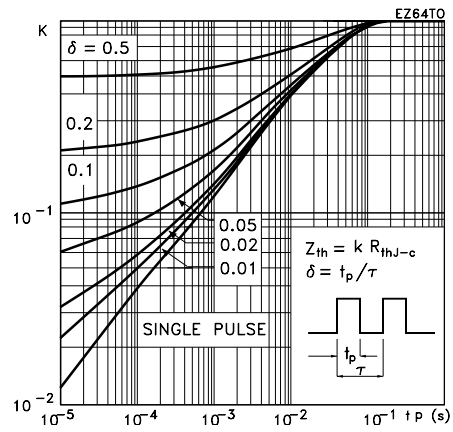

Figure 3. Safe Operating Area for TO-220FP

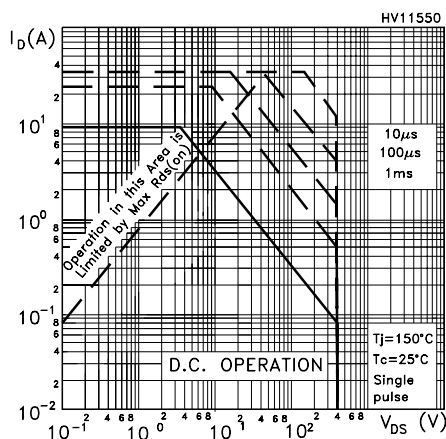

Figure 4. Thermal Impedance for TO-220FP

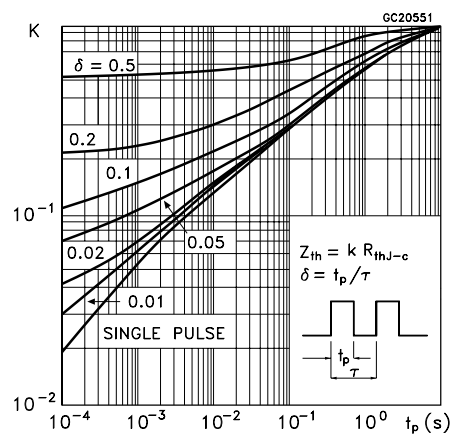

Figure 5. Output Characteristics

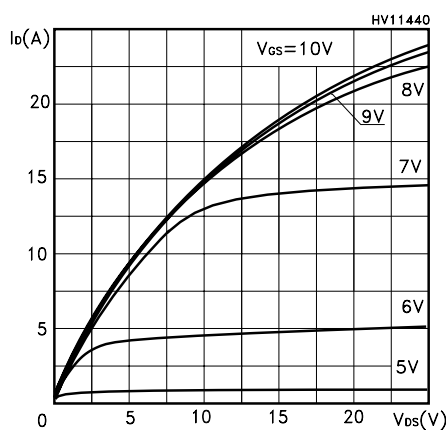

Figure 6. Transfer Characteristics



Figure 7. Transconductance

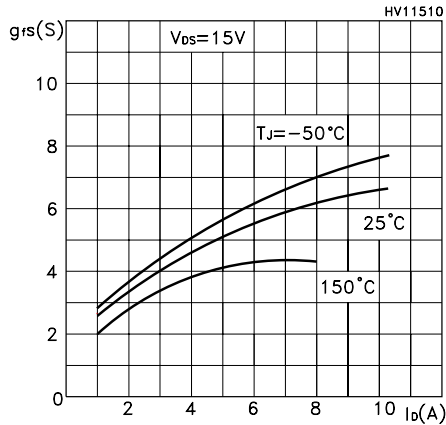

Figure 8. Static Drain-Source on Resistance

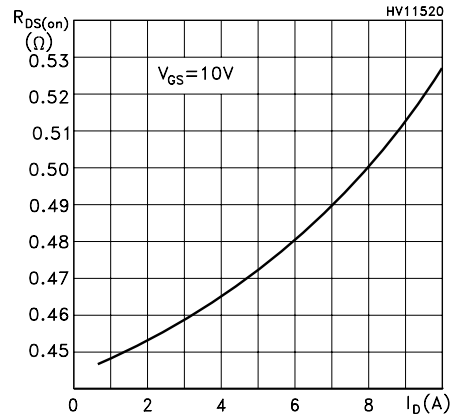

Figure 9. Gate Charge vs Gate -Source Voltage

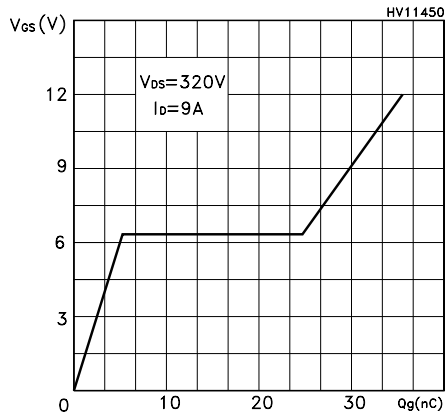

Figure 11. Capacitance Variations

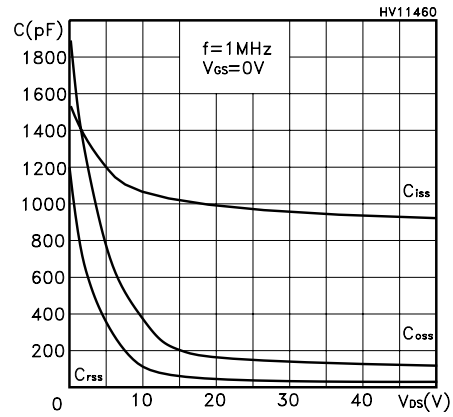

Figure 10. Normalized Gate Threshold Voltage vs Temperature

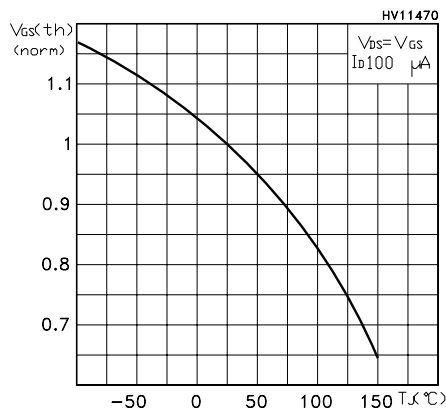

Figure 12. Normalized on Resistance vs Temperature

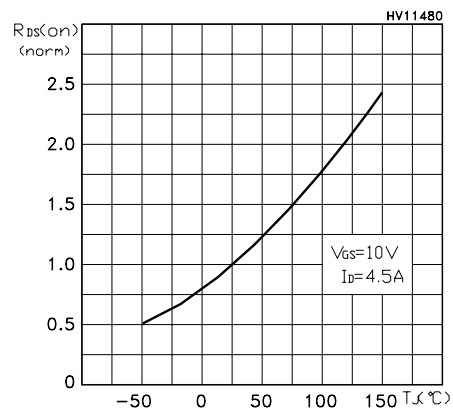

Figure 13. Source-drain Diode Forward Characteristics

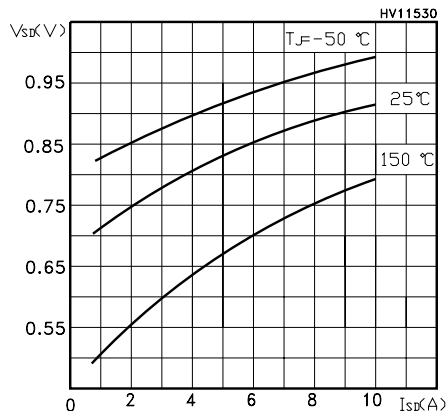

Figure 14. Normalized BVDSS vs Temperature

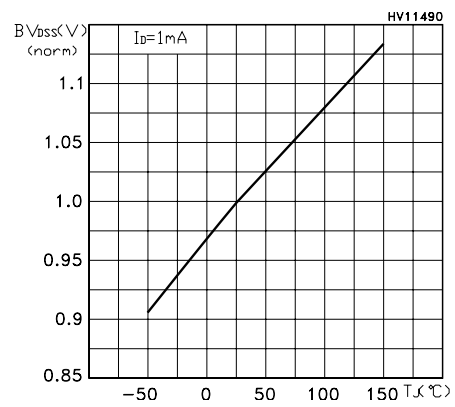
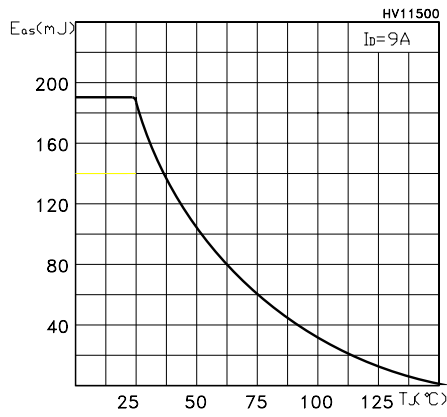

Figure 15. Maximum Avalanche Energy vs Temperature



3 Test circuits

Figure 16. Switching Times Test Circuit For Resistive Load

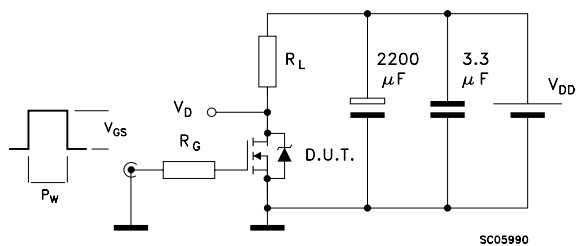

Figure 17. Gate Charge Test Circuit

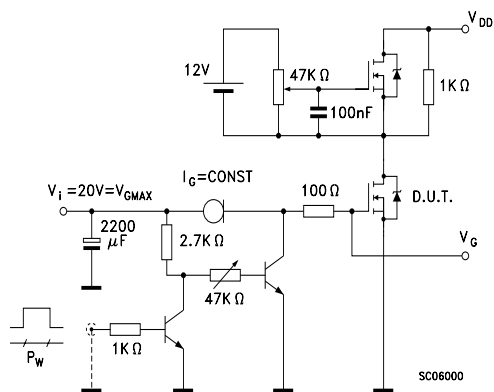

Figure 18. Test Circuit For Inductive Load Switching and Diode Recovery Times

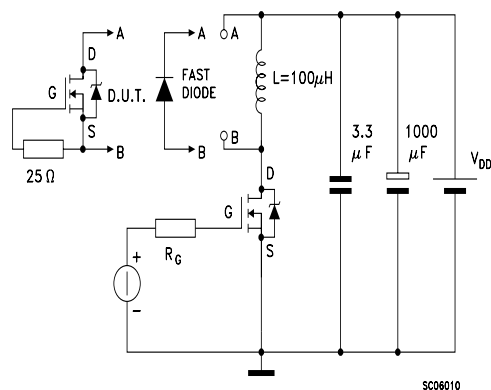

Figure 20. Unclamped Inductive Load Test Circuit

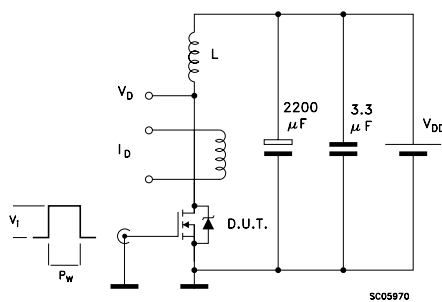
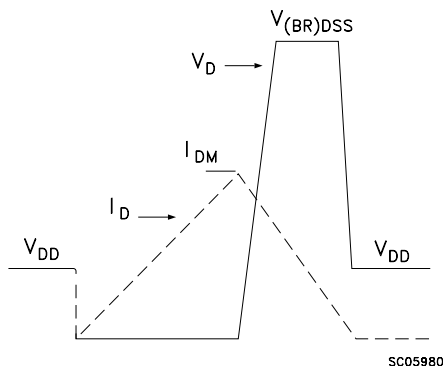

Figure 19. Unclamped Inductive Waveform



4 Package mechanical data

In order to meet environmental requirements, ST offers these devices in ECOPACK® packages. These packages have a Lead-free second level interconnect . The category of second level interconnect is marked on the package and on the inner box label, in compliance with JEDEC Standard JESD97. The maximum ratings related to soldering conditions are also marked on the inner box label. ECOPACK is an ST trademark. ECOPACK specifications are available at: www.st.com

TO-220 MECHANICAL DATA

DIM.	mm.			inch		
	MIN.	TYP.	MAX.	MIN.	TYP.	MAX.
A	4.40		4.60	0.173		0.181
b	0.61		0.88	0.024		0.034
b1	1.15		1.70	0.045		0.066
c	0.49		0.70	0.019		0.027
D	15.25		15.75	0.60		0.620
E	10		10.40	0.393		0.409
e	2.40		2.70	0.094		0.106
e1	4.95		5.15	0.194		0.202
F	1.23		1.32	0.048		0.052
H1	6.20		6.60	0.244		0.256
J1	2.40		2.72	0.094		0.107
L	13		14	0.511		0.551
L1	3.50		3.93	0.137		0.154
L20		16.40			0.645	
L30		28.90			1.137	
øP	3.75		3.85	0.147		0.151
Q	2.65		2.95	0.104		0.116

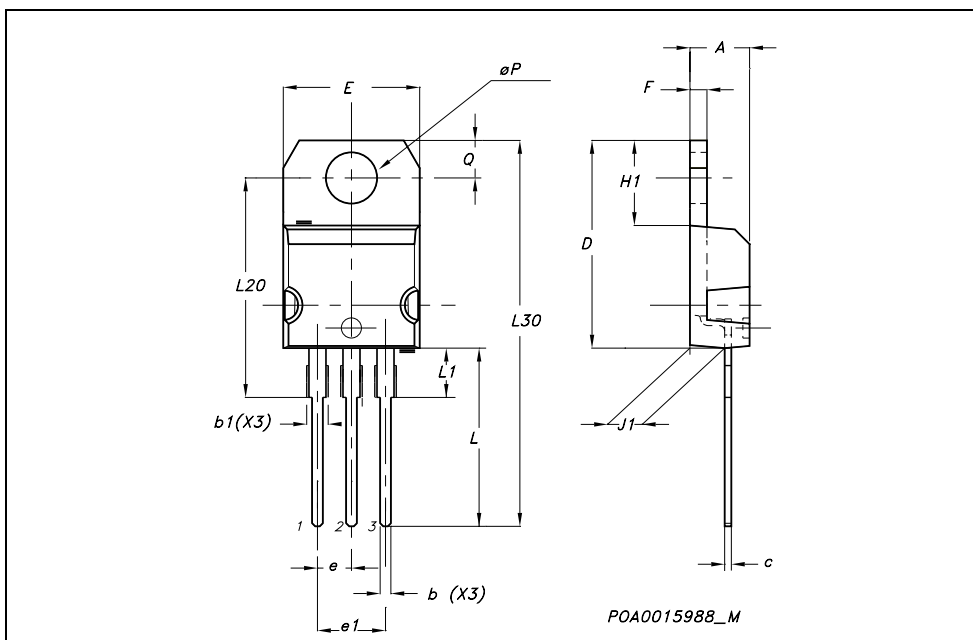

TO-220FP MECHANICAL DATA

DIM.	mm.			inch		
	MIN.	TYP	MAX.	MIN.	TYP.	MAX.
A	4.4		4.6	0.173		0.181
B	2.5		2.7	0.098		0.106
D	2.5		2.75	0.098		0.108
E	0.45		0.7	0.017		0.027
F	0.75		1	0.030		0.039
F1	1.15		1.7	0.045		0.067
F2	1.15		1.7	0.045		0.067
G	4.95		5.2	0.195		0.204
G1	2.4		2.7	0.094		0.106
H	10		10.4	0.393		0.409
L2		16			0.630	
L3	28.6		30.6	1.126		1.204
L4	9.8		10.6	.0385		0.417
L5	2.9		3.6	0.114		0.141
L6	15.9		16.4	0.626		0.645
L7	9		9.3	0.354		0.366
∅	3		3.2	0.118		0.126

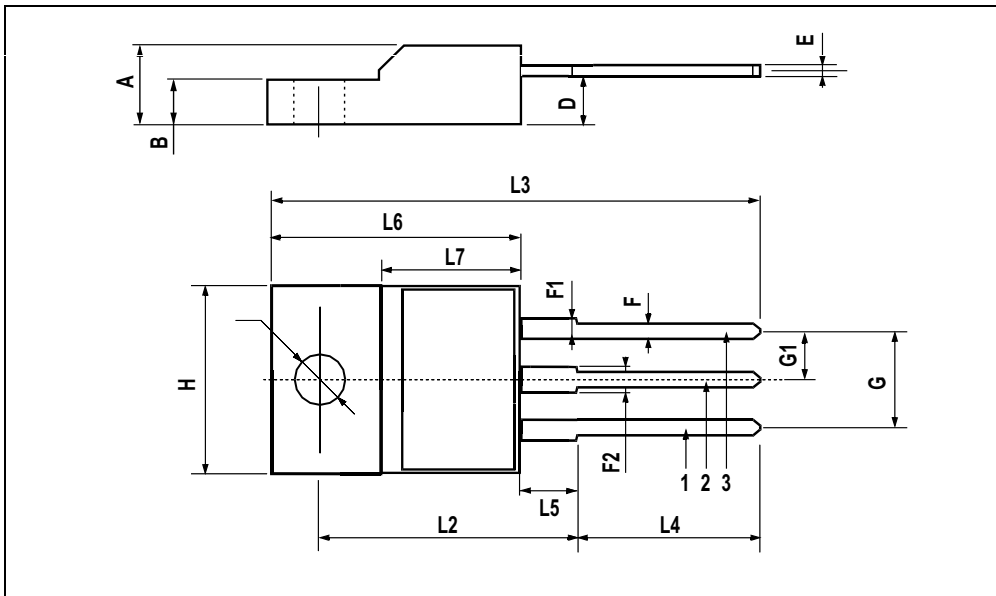

D²PAK MECHANICAL DATA

DIM.	mm.			inch		
	MIN.	TYP	MAX.	MIN.	TYP.	MAX.
A	4.4		4.6	0.173		0.181
A1	2.49		2.69	0.098		0.106
A2	0.03		0.23	0.001		0.009
B	0.7		0.93	0.027		0.036
B2	1.14		1.7	0.044		0.067
C	0.45		0.6	0.017		0.023
C2	1.23		1.36	0.048		0.053
D	8.95		9.35	0.352		0.368
D1		8			0.315	
E	10		10.4	0.393		
E1		8.5			0.334	
G	4.88		5.28	0.192		0.208
L	15		15.85	0.590		0.625
L2	1.27		1.4	0.050		0.055
L3	1.4		1.75	0.055		0.068
M	2.4		3.2	0.094		0.126
R		0.4			0.015	
V2	0°		4°			

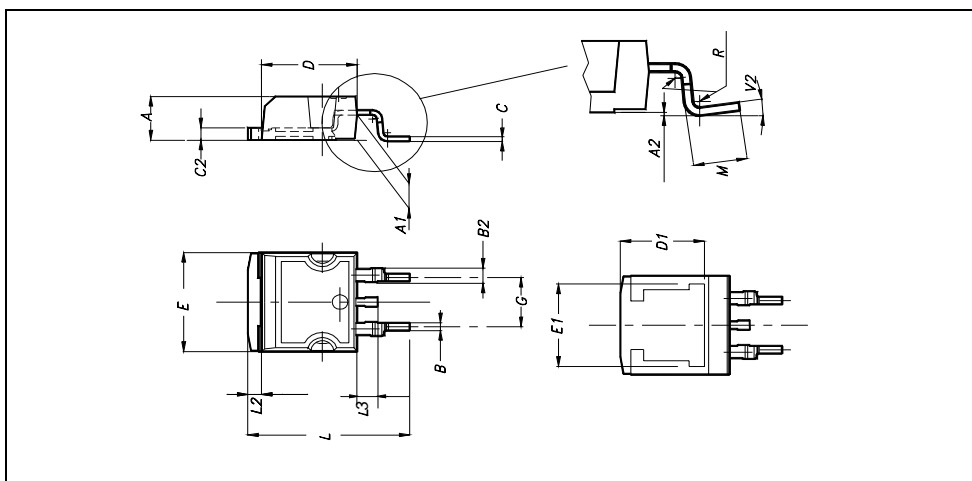

5 Packing mechanical data

D²PAK FOOTPRINT

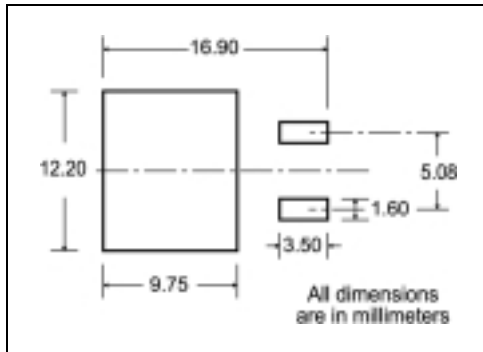

TAPE AND REEL SHIPMENT

TAPE MECHANICAL DATA

DIM.	mm		inch	
	MIN.	MAX.	MIN.	MAX.
A0	10.5	10.7	0.413	0.421
B0	15.7	15.9	0.618	0.626
D	1.5	1.6	0.059	0.063
D1	1.59	1.61	0.062	0.063
E	1.65	1.85	0.065	0.073
F	11.4	11.6	0.449	0.456
K0	4.8	5.0	0.189	0.197
P0	3.9	4.1	0.153	0.161
P1	11.9	12.1	0.468	0.476
P2	1.9	2.1	0.075	0.082
R	50		1.574	
T	0.25	0.35	0.0098	0.0137
W	23.7	24.3	0.933	0.956

REEL MECHANICAL DATA

DIM.	mm		inch	
	MIN.	MAX.	MIN.	MAX.
A		330		12.992
B	1.5		0.059	
C	12.8	13.2	0.504	0.520
D	20.2		0.795	
G	24.4	26.4	0.960	1.039
N	100		3.937	
T		30.4		1.197

BASE QTY	BULK QTY
1000	1000

* on sales type

6 Revision History

Date	Revision	Changes
22-Aug-2005	2	Inserted Ecopack indication

Information furnished is believed to be accurate and reliable. However, STMicroelectronics assumes no responsibility for the consequences of use of such information nor for any infringement of patents or other rights of third parties which may result from its use. No license is granted by implication or otherwise under any patent or patent rights of STMicroelectronics. Specifications mentioned in this publication are subject to change without notice. This publication supersedes and replaces all information previously supplied. STMicroelectronics products are not authorized for use as critical components in life support devices or systems without express written approval of STMicroelectronics.

The ST logo is a registered trademark of STMicroelectronics.
All other names are the property of their respective owners

© 2005 STMicroelectronics - All rights reserved

STMicroelectronics group of companies

Australia - Belgium - Brazil - Canada - China - Czech Republic - Finland - France - Germany - Hong Kong - India - Israel - Italy - Japan -
Malaysia - Malta - Morocco - Singapore - Spain - Sweden - Switzerland - United Kingdom - United States of America

www.st.com

