



# STM32F101x6 STM32F101x8 STM32F101xB

Medium-density access line, ARM-based 32-bit MCU with 32 to 128 KB Flash, six timers, ADC and 7 communication interfaces

## Features

- Core: ARM 32-bit Cortex™-M3 CPU
  - 36 MHz maximum frequency, 1.25 DMIPS/MHz (Dhrystone 2.1) performance at 0 wait state memory access
  - Single-cycle multiplication and hardware division
- Memories
  - 32 to 128 Kbytes of Flash memory
  - 6 to 16 Kbytes of SRAM
- Clock, reset and supply management
  - 2.0 to 3.6 V application supply and I/Os
  - POR, PDR and programmable voltage detector (PVD)
  - 4-to-16 MHz crystal oscillator
  - Internal 8 MHz factory-trimmed RC
  - Internal 40 kHz RC
  - PLL for CPU clock
  - 32 kHz oscillator for RTC with calibration
- Low power
  - Sleep, Stop and Standby modes
  - V<sub>BAT</sub> supply for RTC and backup registers
- Debug mode
  - Serial wire debug (SWD) and JTAG interfaces
- DMA
  - 7-channel DMA controller
  - Peripherals supported: timers, ADC, SPIs, I<sup>2</sup>Cs and USARTs
- 1 × 12-bit, 1 μs A/D converter (up to 16 channels)
  - Conversion range: 0 to 3.6 V
  - Temperature sensor
- Up to 80 fast I/O ports
  - 26/37/51/80 I/Os, all mappable on 16 external interrupt vectors, all 5 V-tolerant except for analog inputs

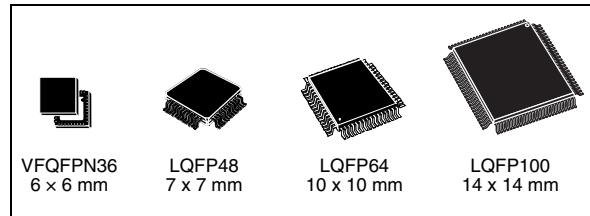

- Up to 6 timers
  - Up to three 16-bit timers, each with up to 4 IC/OC/PWM or pulse counter
  - 2 watchdog timers (Independent and Window)
  - SysTick timer: 24-bit downcounter
- Up to 7 communication interfaces
  - Up to 2 × I<sup>2</sup>C interfaces (SMBus/PMBus)
  - Up to 3 USARTs (ISO 7816 interface, LIN, IrDA capability, modem control)
  - Up to 2 SPIs (18 Mbit/s)
- CRC calculation unit, 96-bit unique ID
- ECOPACK® packages

Table 1. Device summary

Reference	Root part number
STM32F101x6	STM32F101C6, STM32F101R6, STM32F101T6
STM32F101x8	STM32F101C8, STM32F101R8, STM32F101V8, STM32F101T8
STM32F101xB	STM32F101RB, STM32F101VB, STM32F101CB

# Contents

<b>1</b>	<b>Introduction</b>	<b>7</b>
<b>2</b>	<b>Description</b>	<b>7</b>
2.1	Device overview	8
2.2	Full compatibility throughout the family	9
2.3	Overview	10
<b>3</b>	<b>Pin descriptions</b>	<b>17</b>
<b>4</b>	<b>Memory mapping</b>	<b>24</b>
<b>5</b>	<b>Electrical characteristics</b>	<b>25</b>
5.1	Test conditions	25
5.1.1	Minimum and maximum values	25
5.1.2	Typical values	25
5.1.3	Typical curves	25
5.1.4	Loading capacitor	25
5.1.5	Pin input voltage	25
5.1.6	Power supply scheme	26
5.1.7	Current consumption measurement	27
5.2	Absolute maximum ratings	27
5.3	Operating conditions	28
5.3.1	General operating conditions	28
5.3.2	Operating conditions at power-up / power-down	29
5.3.3	Embedded reset and power control block characteristics	29
5.3.4	Embedded reference voltage	31
5.3.5	Supply current characteristics	31
5.3.6	External clock source characteristics	38
5.3.7	Internal clock source characteristics	43
5.3.8	PLL characteristics	44
5.3.9	Memory characteristics	45
5.3.10	EMC characteristics	46
5.3.11	Absolute maximum ratings (electrical sensitivity)	47
5.3.12	I/O port characteristics	48

---

5.3.13	NRST pin characteristics .....	51
5.3.14	TIM timer characteristics .....	52
5.3.15	Communications interfaces .....	52
5.3.16	12-bit ADC characteristics .....	58
5.3.17	Temperature sensor characteristics .....	62
<b>6</b>	<b>Package characteristics .....</b>	<b>63</b>
6.1	Package mechanical data .....	63
6.2	Thermal characteristics .....	68
6.2.1	Reference document .....	68
6.2.2	Evaluating the maximum junction temperature for an application .....	69
<b>7</b>	<b>Ordering information scheme .....</b>	<b>70</b>
7.1	Future family enhancements .....	70
<b>8</b>	<b>Revision history .....</b>	<b>71</b>

## List of tables

Table 1.	Device summary . . . . .	1
Table 2.	Device features and peripheral counts (STM32F101xx Medium-density access line) . . . . .	8
Table 3.	STM32F101xx family . . . . .	9
Table 4.	Medium-density STM32F101xx pin definitions . . . . .	20
Table 5.	Voltage characteristics . . . . .	27
Table 6.	Current characteristics . . . . .	28
Table 7.	Thermal characteristics . . . . .	28
Table 8.	General operating conditions . . . . .	28
Table 9.	Operating conditions at power-up / power-down . . . . .	29
Table 10.	Embedded reset and power control block characteristics . . . . .	30
Table 11.	Embedded internal reference voltage . . . . .	31
Table 12.	Maximum current consumption in Run mode, code with data processing running from Flash . . . . .	31
Table 13.	Maximum current consumption in Run mode, code with data processing running from RAM . . . . .	32
Table 14.	Maximum current consumption in Sleep mode, code running from Flash or RAM . . . . .	33
Table 15.	Typical and maximum current consumptions in Stop and Standby modes . . . . .	34
Table 16.	Typical current consumption in Run mode, code with data processing running from Flash . . . . .	36
Table 17.	Typical current consumption in Sleep mode, code with data processing code running from Flash or RAM . . . . .	37
Table 18.	Peripheral current consumption . . . . .	38
Table 19.	High-speed external user clock characteristics . . . . .	39
Table 20.	Low-speed external user clock characteristics . . . . .	39
Table 21.	HSE 4-16 MHz oscillator characteristics . . . . .	41
Table 22.	LSE oscillator characteristics ( $f_{LSE} = 32.768$ kHz) . . . . .	42
Table 23.	HSI oscillator characteristics . . . . .	43
Table 24.	LSI oscillator characteristics . . . . .	43
Table 25.	Low-power mode wakeup timings . . . . .	44
Table 26.	PLL characteristics . . . . .	44
Table 27.	Flash memory characteristics . . . . .	45
Table 28.	Flash memory endurance and data retention . . . . .	45
Table 29.	EMS characteristics . . . . .	46
Table 30.	EMI characteristics . . . . .	47
Table 31.	ESD absolute maximum ratings . . . . .	47
Table 32.	Electrical sensitivities . . . . .	47
Table 33.	I/O static characteristics . . . . .	48
Table 34.	Output voltage characteristics . . . . .	49
Table 35.	I/O AC characteristics . . . . .	50
Table 36.	NRST pin characteristics . . . . .	51
Table 37.	TIMx characteristics . . . . .	52
Table 38.	I <sup>2</sup> C characteristics . . . . .	53
Table 39.	SCL frequency ( $f_{PCLK1} = 36$ MHz, $V_{DD} = 3.3$ V) . . . . .	54
Table 40.	SPI characteristics . . . . .	55
Table 41.	ADC characteristics . . . . .	58
Table 42.	$R_{AIN}$ max for $f_{ADC} = 14$ MHz . . . . .	59

---

Table 43.	ADC accuracy - limited test conditions	59
Table 44.	ADC accuracy	60
Table 45.	TS characteristics	62
Table 46.	VFQFPN36 6 x 6 mm, 0.5 mm pitch, package mechanical data	64
Table 47.	LQPF100 – 100-pin low-profile quad flat package mechanical data	65
Table 48.	LQFP64 – 64-pin low-profile quad flat package mechanical data	66
Table 49.	LQFP48 – 48-pin low-profile quad flat package mechanical data	67
Table 50.	Thermal characteristics	68
Table 51.	Ordering information scheme	70
Table 52.	Document revision history	71

## List of figures

Figure 1.	STM32F101xx Medium-density access line block diagram . . . . .	15
Figure 2.	Clock tree . . . . .	16
Figure 3.	STM32F101xx Medium-density access line LQFP100 pinout . . . . .	17
Figure 4.	STM32F101xx Medium-density access line LQFP64 pinout . . . . .	18
Figure 5.	STM32F101xx Medium-density access line LQFP48 pinout . . . . .	18
Figure 6.	STM32F101xx Medium-density access line VFQFPN36 pinout. . . . .	19
Figure 7.	Memory map . . . . .	24
Figure 8.	Pin loading conditions . . . . .	26
Figure 9.	Pin input voltage . . . . .	26
Figure 10.	Power supply scheme . . . . .	26
Figure 11.	Current consumption measurement scheme . . . . .	27
Figure 12.	Typical current consumption in Run mode versus frequency (at 3.6 V) - code with data processing running from RAM, peripherals enabled. . . . .	32
Figure 13.	Typical current consumption in Run mode versus frequency (at 3.6 V) - code with data processing running from RAM, peripherals disabled . . . . .	33
Figure 14.	Current consumption in Stop mode with regulator in Run mode versus temperature at $V_{DD} = 3.3\text{ V}$ and $3.6\text{ V}$ . . . . .	34
Figure 15.	Current consumption in Stop mode with regulator in Low-power mode versus temperature at $V_{DD} = 3.3\text{ V}$ and $3.6\text{ V}$ . . . . .	35
Figure 16.	Current consumption in Standby mode versus temperature at $V_{DD} = 3.3\text{ V}$ and $3.6\text{ V}$ . . .	35
Figure 17.	High-speed external clock source AC timing diagram . . . . .	40
Figure 18.	Low-speed external clock source AC timing diagram . . . . .	40
Figure 19.	Typical application with an 8 MHz crystal . . . . .	41
Figure 20.	Typical application with a 32.768 kHz crystal . . . . .	42
Figure 21.	I/O AC characteristics definition . . . . .	51
Figure 22.	Recommended NRST pin protection . . . . .	51
Figure 23.	I <sup>2</sup> C bus AC waveforms and measurement circuit <sup>(1)</sup> . . . . .	54
Figure 24.	SPI timing diagram - slave mode and CPHA = 0 . . . . .	56
Figure 25.	SPI timing diagram - slave mode and CPHA = 1 <sup>(1)</sup> . . . . .	56
Figure 26.	SPI timing diagram - master mode <sup>(1)</sup> . . . . .	57
Figure 27.	ADC accuracy characteristics . . . . .	60
Figure 28.	Typical connection diagram using the ADC . . . . .	61
Figure 29.	Power supply and reference decoupling ( $V_{REF+}$ not connected to $V_{DDA}$ ) . . . . .	61
Figure 30.	Power supply and reference decoupling ( $V_{REF+}$ connected to $V_{DDA}$ ) . . . . .	62
Figure 31.	VFQFPN36 6 x 6 mm, 0.5 mm pitch, package outline <sup>(1)</sup> . . . . .	64
Figure 32.	Recommended footprint (dimensions in mm) <sup>(1)(2)(3)</sup> . . . . .	64
Figure 33.	LQFP100, 100-pin low-profile quad flat package outline . . . . .	65
Figure 34.	Recommended footprint <sup>(1)</sup> . . . . .	65
Figure 35.	LQFP64 – 64 pin low-profile quad flat package outline . . . . .	66
Figure 36.	Recommended footprint <sup>(1)</sup> . . . . .	66
Figure 37.	LQFP48 – 48-pin low-profile quad flat package outline. . . . .	67
Figure 38.	Recommended footprint <sup>(1)</sup> . . . . .	67
Figure 39.	LQFP64 $P_D$ max vs. $T_A$ . . . . .	69

# 1 Introduction

This datasheet provides the ordering information and mechanical device characteristics of the STM32F101x6, STM32F101x8 and STM32F101xB Medium-density Access line microcontrollers. For more details on the whole STMicroelectronics STM32F101xx family, please refer to [Section 2.2: Full compatibility throughout the family](#).

The Medium-density STM32F101xx datasheet should be read in conjunction with the Medium- and High-density STM32F10xxx reference manual.

For information on programming, erasing and protection of the internal Flash memory please refer to the *STM32F10xxx Flash programming manual*.

The reference and Flash programming manuals are both available from the STMicroelectronics website [www.st.com](http://www.st.com).

For information on the Cortex™-M3 core please refer to the Cortex™-M3 Technical Reference Manual, available from the [www.arm.com](http://www.arm.com) website at the following address: <http://infocenter.arm.com/help/index.jsp?topic=/com.arm.doc.ddi0337e/>.

# 2 Description

The STM32F101x6, STM32F101xB and STM32F101x8 Medium-density access line family incorporates the high-performance ARM Cortex™-M3 32-bit RISC core operating at a 36 MHz frequency, high-speed embedded memories (Flash memory up to 128 Kbytes and SRAM up to 16 Kbytes), and an extensive range of enhanced peripherals and I/Os connected to two APB buses. All devices offer standard communication interfaces (two I<sup>2</sup>Cs, two SPIs, and up to three USARTs), one 12-bit ADC and three general-purpose 16-bit timers.

The STM32F101xx Medium-density Access line family operates in the –40 to +85 °C temperature range, from a 2.0 to 3.6 V power supply. A comprehensive set of power-saving mode allows the design of low-power applications.

The STM32F101xx Medium-density access line family includes devices in four different packages ranging from 36 pins to 100 pins. Depending on the device chosen, different sets of peripherals are included, the description below gives an overview of the complete range of peripherals proposed in this family.

These features make the STM32F101xx Medium-density Access line microcontroller family suitable for a wide range of applications:

- Application control and user interface
- Medical and handheld equipment
- PC peripherals, gaming and GPS platforms
- Industrial applications: PLC, inverters, printers, and scanners
- Alarm systems, Video intercom, and HVAC

[Figure 1](#) shows the general block diagram of the device family.

## 2.1 Device overview

Table 2. Device features and peripheral counts (STM32F101xx Medium-density access line)

Peripheral		STM32F101Tx		STM32F101Cx			STM32F101Rx			STM32F101Vx	
Flash - Kbytes		32	64	32	64	128	32	64	128	64	128
SRAM - Kbytes		6	10	6	10	16	6	10	16	10	16
Timers	General purpose	2	3	2	3	3	2	3	3	3	3
	Communication										
	SPI	1	1	1	2	2	1	2	2	2	2
	I <sup>2</sup> C	1	1	1	2	2	1	2	2	2	2
	USART	2	2	2	3	3	2	3	3	3	3
12-bit synchronized ADC number of channels		1 10 channels		1 10 channels			1 16 channels			1 16 channels	
GPIOs		26		37			51			80	
CPU frequency		36 MHz									
Operating voltage		2.0 to 3.6 V									
Operating temperatures		Ambient temperature: -40 to +85 °C (see <a href="#">Table 8</a> ) Junction temperature: -40 to +105 °C (see <a href="#">Table 8</a> )									
Packages		VFQFPN36		LQFP48			LQFP64			LQFP100	



## 2.2 Full compatibility throughout the family

The STM32F101xx is a complete family whose members are fully pin-to-pin, software and feature compatible. In the reference manual, the STM32F101x6, STM32F101x8 and STM32F101xB are referred to as Medium-density devices, while the STM32F101xC, STM32F101xD and STM32F101xE are referred to as High-density devices.

High-density devices are an extension of the STM32F101x6/8/B devices, they are specified in the STM32F101xC/D/E datasheet. They feature higher Flash memory and RAM densities, and additional peripherals like FSMC and DAC, while remaining fully compatible with the other members of the family.

The STM32F101xC, STM32F101xD and STM32F101xE are a drop-in replacement for the STM32F101x6/8/B devices, allowing the user to try different memory densities and providing a greater degree of freedom during the development cycle.

**Table 3. STM32F101xx family**

Pinout	Memory size					
	Medium-density STM32F101xx devices			High-density STM32F101xx devices		
	32 KB Flash	64 KB Flash	128 KB Flash	256 KB Flash	384 KB Flash	512 KB Flash
	6 KB RAM	10 KB RAM	16 KB RAM	32 KB RAM	48 KB RAM	48 KB RAM
144				5 × USARTs		
100		3 × USARTs			4 × 16-bit timers, 2 × basic timers	
64	2 × USARTs	3 × 16-bit timers			3 × SPIs, 2 × I <sup>2</sup> Cs, 1 × ADC, 1 × DAC	
48	2 × 16-bit timers	2 × SPIs, 2 × I2Cs, 1 × ADC			FSMC (100 and 144 pins)	
	1 × SPI, 1 × I <sup>2</sup> C					
36	1 × ADC					

## 2.3 Overview

### ARM® Cortex™-M3 core with embedded Flash and SRAM

The ARM Cortex™-M3 processor is the latest generation of ARM processors for embedded systems. It has been developed to provide a low-cost platform that meets the needs of MCU implementation, with a reduced pin count and low-power consumption, while delivering outstanding computational performance and an advanced system response to interrupts.

The ARM Cortex™-M3 32-bit RISC processor features exceptional code-efficiency, delivering the high-performance expected from an ARM core in the memory size usually associated with 8- and 16-bit devices.

The STM32F101xx Medium-density access line family having an embedded ARM core, is therefore compatible with all ARM tools and software.

### Embedded Flash memory

Up to 128 Kbytes of embedded Flash is available for storing programs and data.

### CRC (cyclic redundancy check) calculation unit

The CRC (cyclic redundancy check) calculation unit is used to get a CRC code from a 32-bit data word and a fixed generator polynomial.

Among other applications, CRC-based techniques are used to verify data transmission or storage integrity. In the scope of the EN/IEC 60335-1 standard, they offer a means of verifying the Flash memory integrity. The CRC calculation unit helps compute a signature of the software during runtime, to be compared with a reference signature generated at link-time and stored at a given memory location.

### Embedded SRAM

Up to 16 Kbytes of embedded SRAM accessed (read/write) at CPU clock speed with 0 wait states.

### Nested vectored interrupt controller (NVIC)

The STM32F101xx Medium-density access line embeds a nested vectored interrupt controller able to handle up to 43 maskable interrupt channels (not including the 16 interrupt lines of Cortex™-M3) and 16 priority levels.

- Closely coupled NVIC gives low latency interrupt processing
- Interrupt entry vector table address passed directly to the core
- Closely coupled NVIC core interface
- Allows early processing of interrupts
- Processing of *late arriving* higher priority interrupts
- Support for tail-chaining
- Processor state automatically saved
- Interrupt entry restored on interrupt exit with no instruction overhead

This hardware block provides flexible interrupt management features with minimal interrupt latency.

## External interrupt/event controller (EXTI)

The external interrupt/event controller consists of 19 edge detector lines used to generate interrupt/event requests. Each line can be independently configured to select the trigger event (rising edge, falling edge, both) and can be masked independently. A pending register maintains the status of the interrupt requests. The EXTI can detect an external line with a pulse width shorter than the Internal APB2 clock period. Up to 80 GPIOs can be connected to the 16 external interrupt lines.

## Clocks and startup

System clock selection is performed on startup, however the internal RC 8 MHz oscillator is selected as default CPU clock on reset. An external 4-16 MHz clock can be selected, in which case it is monitored for failure. If failure is detected, the system automatically switches back to the internal RC oscillator. A software interrupt is generated if enabled. Similarly, full interrupt management of the PLL clock entry is available when necessary (for example on failure of an indirectly used external crystal, resonator or oscillator).

Several prescalers allow the configuration of the AHB frequency, the high-speed APB (APB2) and the low-speed APB (APB1) domains. The maximum frequency of the AHB and the APB domains is 36 MHz. See [Figure 2](#) for details on the clock tree.

## Boot modes

At startup, boot pins are used to select one of three boot options:

- Boot from User Flash
- Boot from System Memory
- Boot from embedded SRAM

The boot loader is located in System Memory. It is used to reprogram the Flash memory by using USART1. For further details please refer to AN2606.

## Power supply schemes

- $V_{DD} = 2.0$  to  $3.6$  V: External power supply for I/Os and the internal regulator. Provided externally through  $V_{DD}$  pins.
- $V_{SSA}$ ,  $V_{DDA} = 2.0$  to  $3.6$  V: External analog power supplies for ADC, Reset blocks, RCs and PLL (minimum voltage to be applied to  $V_{DDA}$  is 2.4 V when the ADC is used).  $V_{DDA}$  and  $V_{SSA}$  must be connected to  $V_{DD}$  and  $V_{SS}$ , respectively.
- $V_{BAT} = 1.8$  to  $3.6$  V: Power supply for RTC, external clock 32 kHz oscillator and backup registers (through power switch) when  $V_{DD}$  is not present.

For more details on how to connect power pins, refer to [Figure 10: Power supply scheme](#).

## Power supply supervisor

The device has an integrated power on reset (POR)/power down reset (PDR) circuitry. It is always active, and ensures proper operation starting from/down to 2 V. The device remains in reset mode when  $V_{DD}$  is below a specified threshold,  $V_{POR/PDR}$ , without the need for an external reset circuit.

The device features an embedded programmable voltage detector (PVD) that monitors the  $V_{DD}/V_{DDA}$  power supply and compares it to the  $V_{PVD}$  threshold. An interrupt can be generated when  $V_{DD}/V_{DDA}$  drops below the  $V_{PVD}$  threshold and/or when  $V_{DD}/V_{DDA}$  is higher

than the  $V_{PVD}$  threshold. The interrupt service routine can then generate a warning message and/or put the MCU into a safe state. The PVD is enabled by software.

Refer to [Table 10: Embedded reset and power control block characteristics](#) for the values of  $V_{POR/PDR}$  and  $V_{PVD}$ .

### Voltage regulator

The regulator has three operation modes: main (MR), low power (LPR) and power down.

- MR is used in the nominal regulation mode (Run)
- LPR is used in the Stop mode
- Power down is used in Standby mode: the regulator output is in high impedance: the kernel circuitry is powered down, inducing zero consumption (but the contents of the registers and SRAM are lost)

This regulator is always enabled after reset. It is disabled in Standby mode, providing high impedance output.

### Low-power modes

The STM32F101xx Medium-density access line supports three low-power modes to achieve the best compromise between low power consumption, short startup time and available wakeup sources:

- **Sleep mode**  
In Sleep mode, only the CPU is stopped. All peripherals continue to operate and can wake up the CPU when an interrupt/event occurs.
- **Stop mode**  
Stop mode achieves the lowest power consumption while retaining the content of SRAM and registers. All clocks in the 1.8 V domain are stopped, the PLL, the HSI RC and the HSE crystal oscillators are disabled. The voltage regulator can also be put either in normal or in low power mode.  
The device can be woken up from Stop mode by any of the EXTI line. The EXTI line source can be one of the 16 external lines, the PVD output or the RTC alarm.
- **Standby mode**  
The Standby mode is used to achieve the lowest power consumption. The internal voltage regulator is switched off so that the entire 1.8 V domain is powered off. The PLL, the HSI RC and the HSE crystal oscillators are also switched off. After entering Standby mode, SRAM and register contents are lost except for registers in the Backup domain and Standby circuitry.  
The device exits Standby mode when an external reset (NRST pin), a IWDG reset, a rising edge on the WKUP pin, or an RTC alarm occurs.

*Note:* The RTC, the IWDG, and the corresponding clock sources are not stopped by entering Stop or Standby mode.

### DMA

The flexible 7-channel general-purpose DMA is able to manage memory-to-memory, peripheral-to-memory and memory-to-peripheral transfers. The DMA controller supports circular buffer management avoiding the generation of interrupts when the controller reaches the end of the buffer.

Each channel is connected to dedicated hardware DMA requests, with support for software trigger on each channel. Configuration is made by software and transfer sizes between source and destination are independent.

The DMA can be used with the main peripherals: SPI, I<sup>2</sup>C, USART, general purpose timers TIMx and ADC.

### RTC (real-time clock) and backup registers

The RTC and the backup registers are supplied through a switch that takes power either on V<sub>DD</sub> supply when present or through the V<sub>BAT</sub> pin. The backup registers are ten 16-bit registers used to store 20 bytes of user application data when V<sub>DD</sub> power is not present.

The real-time clock provides a set of continuously running counters which can be used with suitable software to provide a clock calendar function, and provides an alarm interrupt and a periodic interrupt. It is clocked by a 32.768 kHz external crystal, resonator or oscillator, the internal low power RC oscillator or the high-speed external clock divided by 128. The internal low power RC has a typical frequency of 40 kHz. The RTC can be calibrated using an external 512 Hz output to compensate for any natural crystal deviation. The RTC features a 32-bit programmable counter for long term measurement using the Compare register to generate an alarm. A 20-bit prescaler is used for the time base clock and is by default configured to generate a time base of 1 second from a clock at 32.768 kHz.

### Independent watchdog

The independent watchdog is based on a 12-bit downcounter and 8-bit prescaler. It is clocked from an independent 40 kHz internal RC and as it operates independently from the main clock, it can operate in Stop and Standby modes. It can be used as a watchdog to reset the device when a problem occurs, or as a free running timer for application timeout management. It is hardware or software configurable through the option bytes. The counter can be frozen in debug mode.

### Window watchdog

The window watchdog is based on a 7-bit downcounter that can be set as free running. It can be used as a watchdog to reset the device when a problem occurs. It is clocked from the main clock. It has an early warning interrupt capability and the counter can be frozen in debug mode.

### SysTick timer

This timer is dedicated for OS, but could also be used as a standard down counter. It features:

- A 24-bit down counter
- Autoreload capability
- Maskable system interrupt generation when the counter reaches 0.
- Programmable clock source

### General-purpose timers (TIMx)

There are up to three synchronizable general-purpose timers embedded in the STM32F101xx Medium-density access line devices. These timers are based on a 16-bit auto-reload up/down counter, a 16-bit prescaler and feature 4 independent channels each for input capture, output compare, PWM or one pulse mode output. This gives up to 12 input

captures / output compares / PWMs on the largest packages. They can work together via the Timer Link feature for synchronization or event chaining.

The counter can be frozen in debug mode.

Any of the standard timers can be used to generate PWM outputs. Each of the timers has independent DMA request generations.

### **I<sup>2</sup>C bus**

Up to two I<sup>2</sup>C bus interfaces can operate in multimaster and slave modes. They can support standard and fast modes.

They support dual slave addressing (7-bit only) and both 7/10-bit addressing in master mode. A hardware CRC generation/verification is embedded.

They can be served by DMA and they support SM Bus 2.0/PM Bus.

### **Universal synchronous/asynchronous receiver transmitter (USART)**

The available USART interfaces communicate at up to 2.25 Mbit/s. They provide hardware management of the CTS and RTS signals, support IrDA SIR ENDEC, are ISO 7816 compliant and have LIN Master/Slave capability.

The USART interfaces can be served by the DMA controller.

### **Serial peripheral interface (SPI)**

Up to two SPIs are able to communicate up to 18 Mbit/s in slave and master modes in full-duplex and simplex communication modes. The 3-bit prescaler gives 8 master mode frequencies and the frame is configurable to 8 bits or 16 bits. The hardware CRC generation/verification supports basic SD Card/MMC modes.

Both SPIs can be served by the DMA controller.

### **GPIOs (general-purpose inputs/outputs)**

Each of the GPIO pins can be configured by software as output (push-pull or open-drain), as input (with or without pull-up or pull-down) or as peripheral alternate function. Most of the GPIO pins are shared with digital or analog alternate functions. All GPIOs are high current-capable except for analog inputs.

The I/Os alternate function configuration can be locked if needed following a specific sequence in order to avoid spurious writing to the I/Os registers.

### **ADC (analog to digital converter)**

The 12-bit analog to digital converter has up to 16 external channels and performs conversions in single-shot or scan modes. In scan mode, automatic conversion is performed on a selected group of analog inputs.

The ADC can be served by the DMA controller.

An analog watchdog feature allows very precise monitoring of the converted voltage of one, some or all selected channels. An interrupt is generated when the converted voltage is outside the programmed thresholds.

### Temperature sensor

The temperature sensor has to generate a linear voltage with any variation in temperature. The conversion range is between  $2\text{ V} < V_{\text{DDA}} < 3.6\text{ V}$ . The temperature sensor is internally connected to the ADC\_IN16 input channel which is used to convert the sensor output voltage into a digital value.

### Serial wire JTAG debug port (SWJ-DP)

The ARM SWJ-DP Interface is embedded, and is a combined JTAG and serial wire debug port that enables either a serial wire debug or a JTAG probe to be connected to the target. The JTAG TMS and TCK pins are shared respectively with SWDIO and SWCLK and a specific sequence on the TMS pin is used to switch between JTAG-DP and SW-DP.

Figure 1. STM32F101xx Medium-density access line block diagram

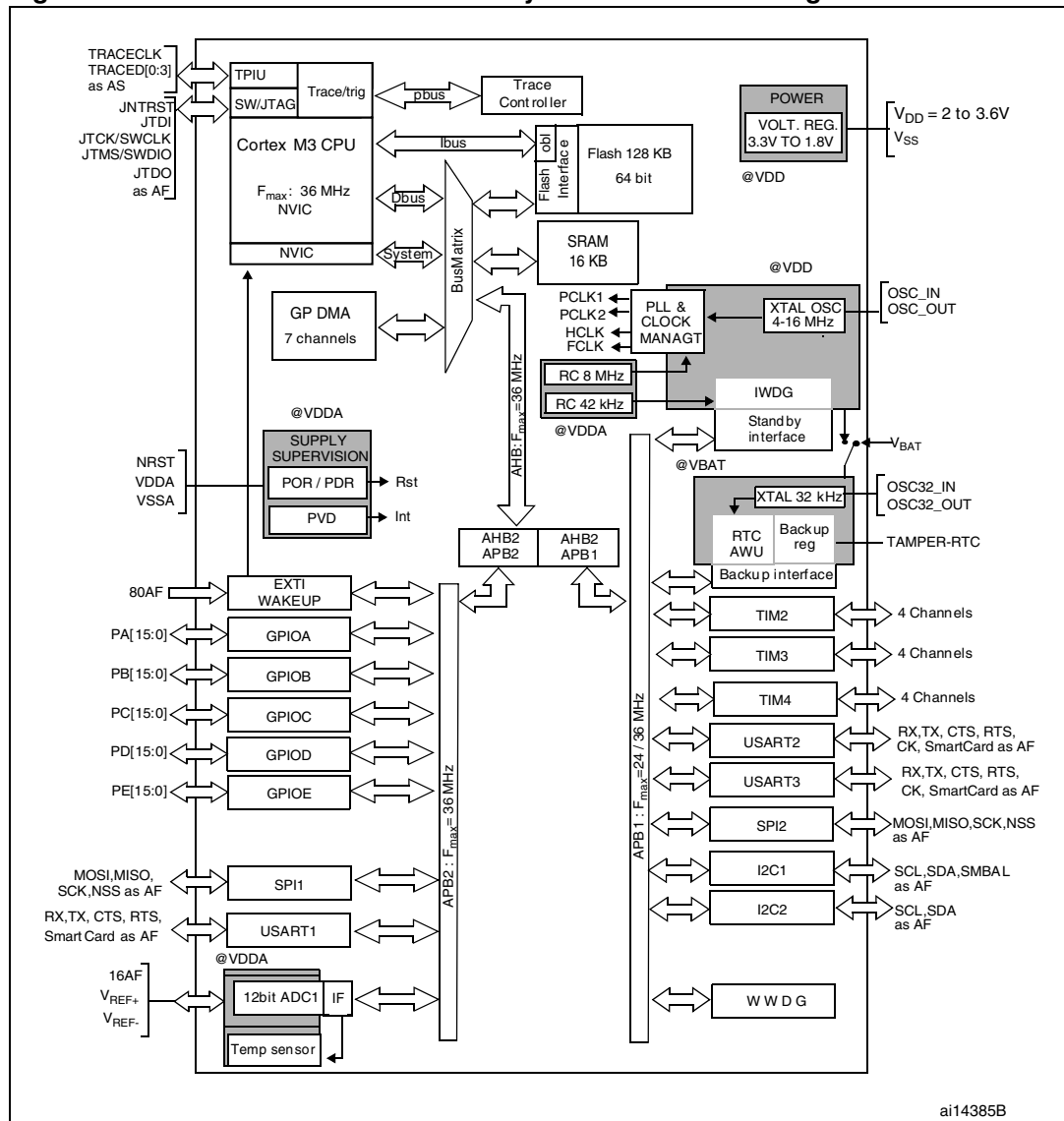

1. AF = alternate function on I/O port pin.
2.  $T_A = -40\text{ }^\circ\text{C}$  to  $+85\text{ }^\circ\text{C}$  (junction temperature up to  $105\text{ }^\circ\text{C}$ ).

Figure 2. Clock tree

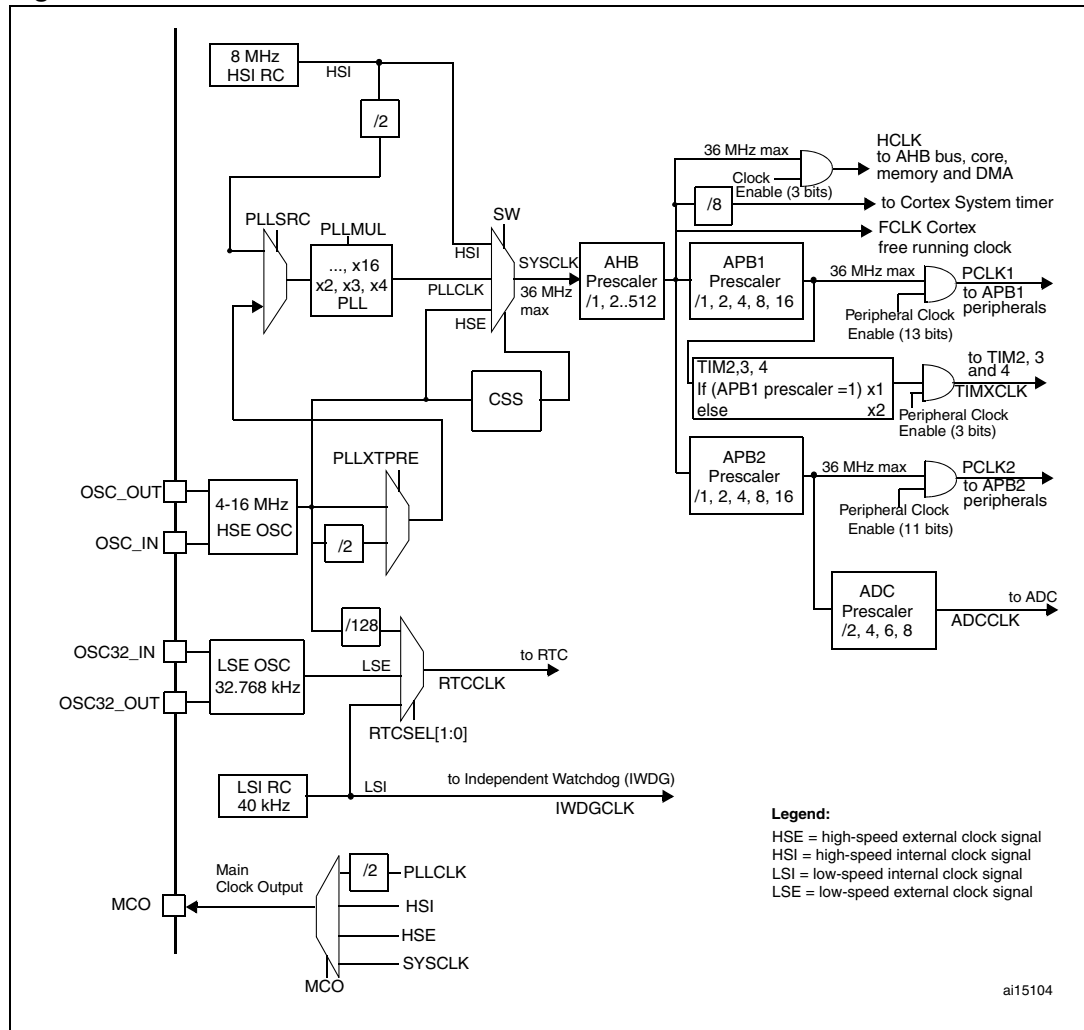

1. When the HSI is used as a PLL clock input, the maximum system clock frequency that can be achieved is 36 MHz.
2. To have an ADC conversion time of 1  $\mu$ s, APB2 must be at 14 MHz or 28 MHz.

### 3 Pin descriptions

Figure 3. STM32F101xx Medium-density access line LQFP100 pinout

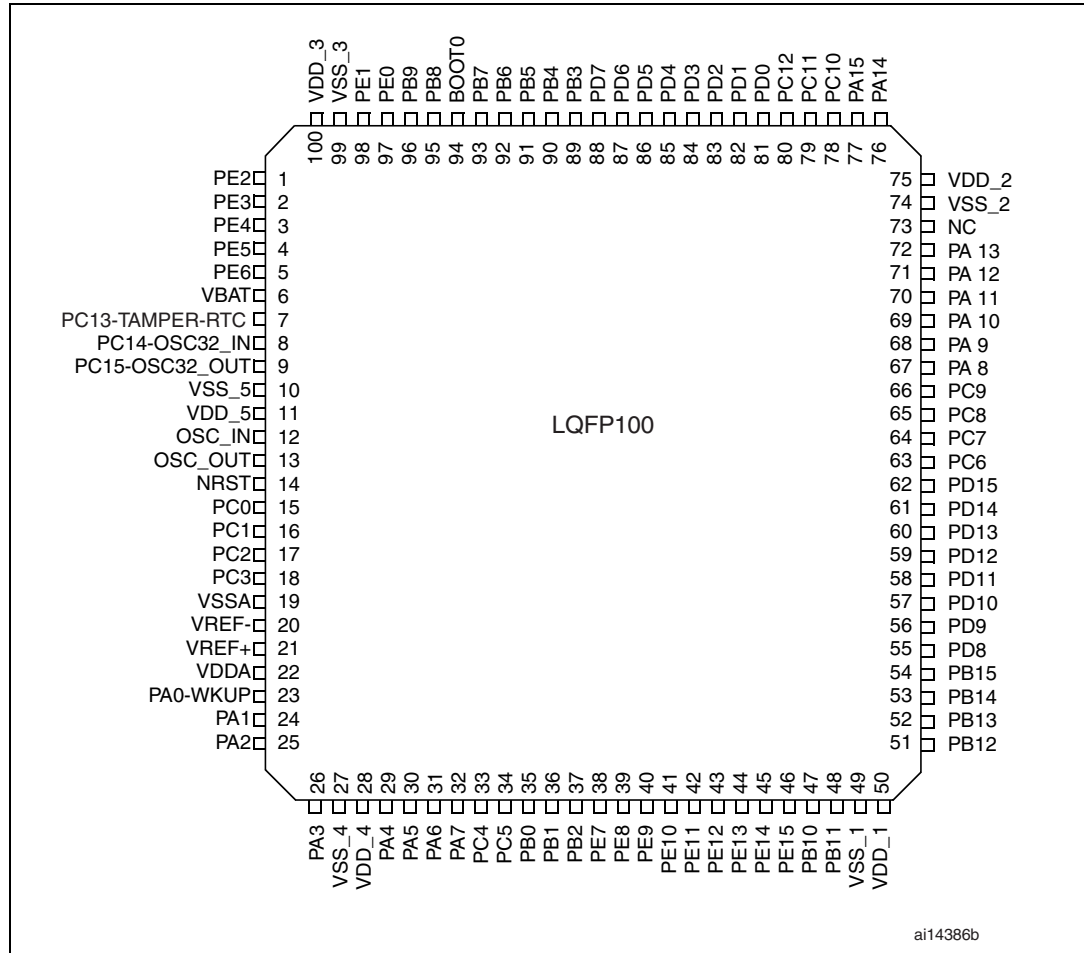

Figure 4. STM32F101xx Medium-density access line LQFP64 pinout

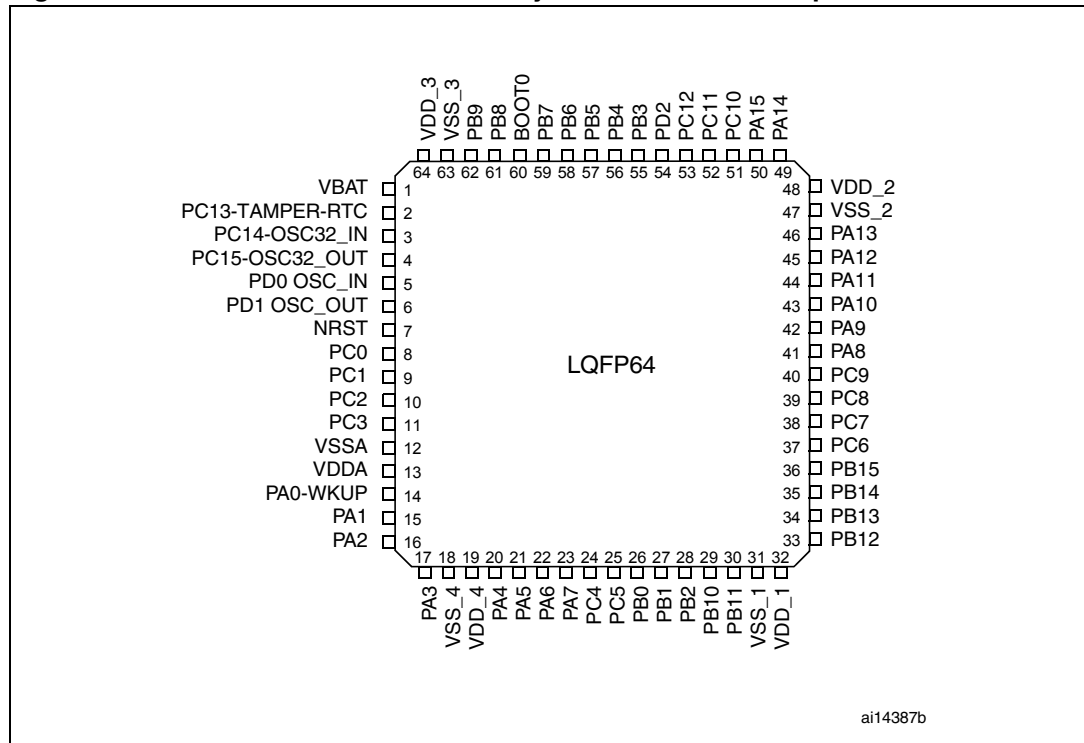

Figure 5. STM32F101xx Medium-density access line LQFP48 pinout

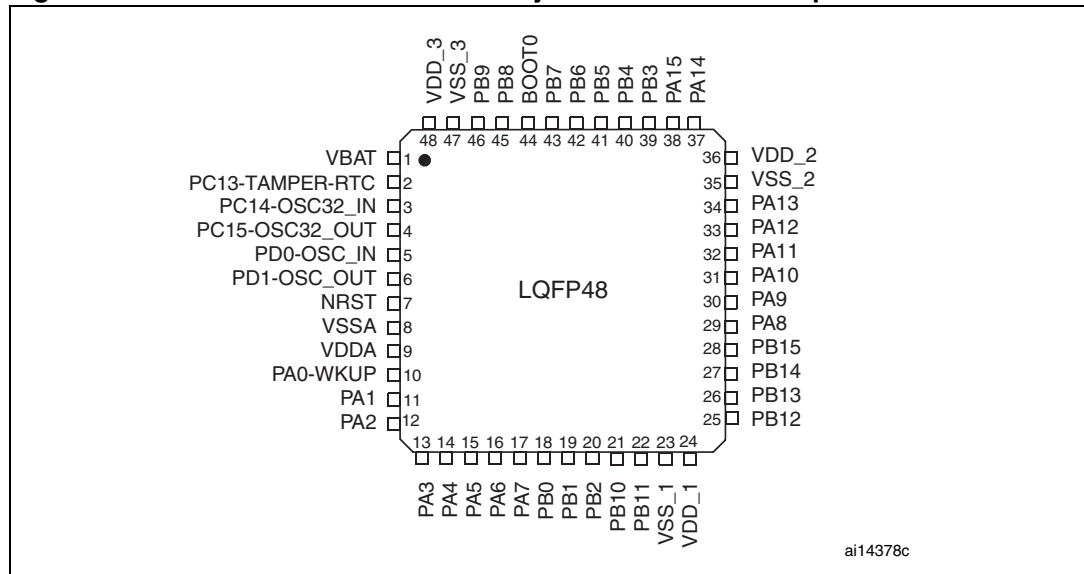

Figure 6. STM32F101xx Medium-density access line VFQFPN36 pinout

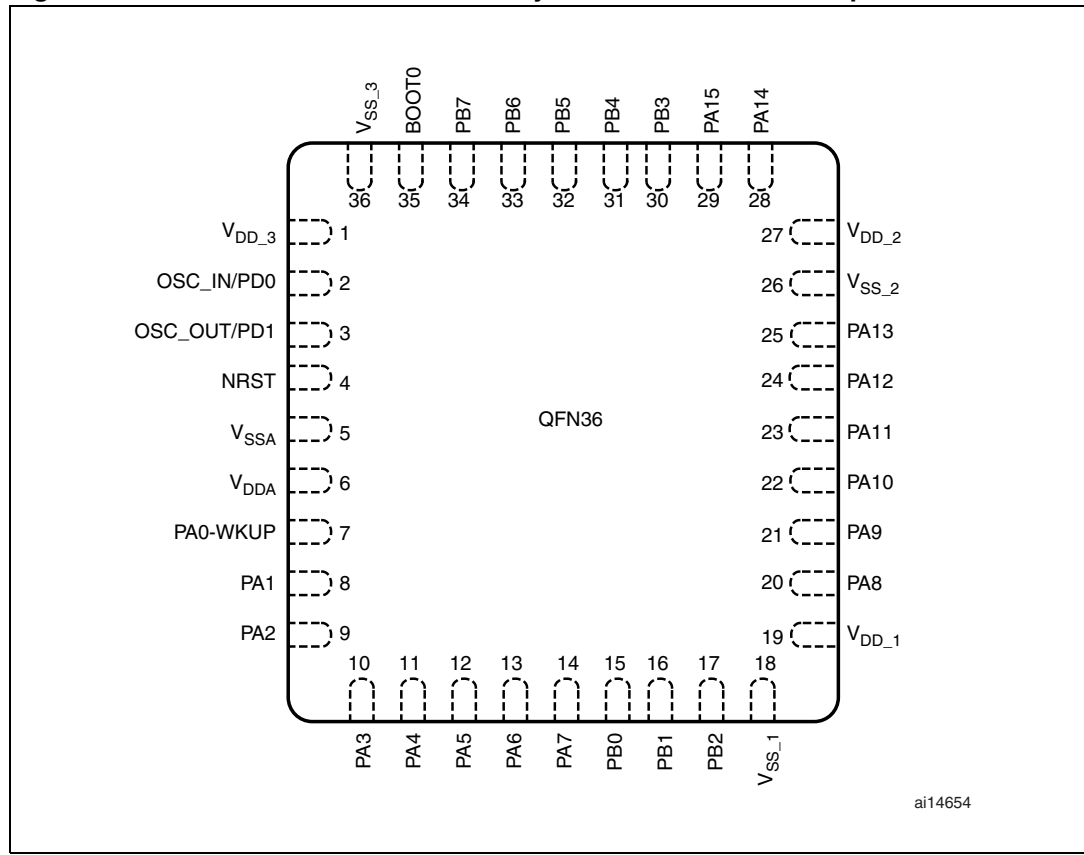

Table 4. Medium-density STM32F101xx pin definitions

Pins				Pin name	Type <sup>(1)</sup>	I/O level <sup>(2)</sup>	Main function <sup>(3)</sup> (after reset)	Alternate functions <sup>(3)</sup>	
LQFP48	LQFP64	LQFP100	VFQFPN36					Default	Remap
-	-	1	-	PE2	I/O	FT	PE2	TRACECLK	
-	-	2	-	PE3	I/O	FT	PE3	TRACED0	
-	-	3	-	PE4	I/O	FT	PE4	TRACED1	
-	-	4	-	PE5	I/O	FT	PE5	TRACED2	
-	-	5	-	PE6	I/O	FT	PE6	TRACED3	
1	1	6	-	V <sub>BAT</sub>	S		V <sub>BAT</sub>		
2	2	7	-	PC13-TAMPER-RTC <sup>(4)</sup>	I/O		PC13 <sup>(5)</sup>	TAMPER-RTC	
3	3	8	-	PC14-OSC32_IN <sup>(4)</sup>	I/O		PC14 <sup>(5)</sup>	OSC32_IN	
4	4	9	-	PC15-OSC32_OUT <sup>(4)</sup>	I/O		PC15 <sup>(5)</sup>	OSC32_OUT	
-	-	10	-	V <sub>SS_5</sub>	S		V <sub>SS_5</sub>		
-	-	11	-	V <sub>DD_5</sub>	S		V <sub>DD_5</sub>		
5	5	12	2	OSC_IN	I		OSC_IN		
6	6	13	3	OSC_OUT	O		OSC_OUT		
7	7	14	4	NRST	I/O		NRST		
-	8	15	-	PC0	I/O		PC0	ADC_IN10	
-	9	16	-	PC1	I/O		PC1	ADC_IN11	
-	10	17	-	PC2	I/O		PC2	ADC_IN12	
-	11	18	-	PC3	I/O		PC3	ADC_IN13	
8	12	19	5	V <sub>SSA</sub>	S		V <sub>SSA</sub>		
-	-	20	-	V <sub>REF-</sub>	S		V <sub>REF-</sub>		
-	-	21	-	V <sub>REF+</sub>	S		V <sub>REF+</sub>		
9	13	22	6	V <sub>DDA</sub>	S		V <sub>DDA</sub>		
10	14	23	7	PA0-WKUP	I/O		PA0	WKUP/USART2_CTS <sup>(8)</sup> / ADC_IN0/ TIM2_CH1_ETR <sup>(8)</sup>	
11	15	24	8	PA1	I/O		PA1	USART2_RTS <sup>(8)</sup> / ADC_IN1/TIM2_CH2 <sup>(8)</sup>	
12	16	25	9	PA2	I/O		PA2	USART2_TX <sup>(8)</sup> / ADC_IN2/TIM2_CH3 <sup>(8)</sup>	
13	17	26	10	PA3	I/O		PA3	USART2_RX <sup>(8)</sup> / ADC_IN3/TIM2_CH4 <sup>(8)</sup>	
-	18	27	-	V <sub>SS_4</sub>	S		V <sub>SS_4</sub>		

Table 4. Medium-density STM32F101xx pin definitions (continued)

Pins				Pin name	Type <sup>(1)</sup>	I/O level <sup>(2)</sup>	Main function <sup>(3)</sup> (after reset)	Alternate functions <sup>(3)</sup>	
LQFP48	LQFP64	LQFP100	VFQFPN36					Default	Remap
-	19	28	-	V <sub>DD_4</sub>	S		V <sub>DD_4</sub>		
14	20	29	11	PA4	I/O		PA4	SPI1_NSS/ADC_IN4 USART2_CK <sup>(8)</sup> /	
15	21	30	12	PA5	I/O		PA5	SPI1_SCK/ADC_IN5	
16	22	31	13	PA6	I/O		PA6	SPI1_MISO/ADC_IN6/ TIM3_CH1 <sup>(8)</sup>	
17	23	32	14	PA7	I/O		PA7	SPI1_MOSI/ADC_IN7/ TIM3_CH2 <sup>(8)</sup>	
-	24	33		PC4	I/O		PC4	ADC_IN14	
-	25	34		PC5	I/O		PC5	ADC_IN15	
18	26	35	15	PB0	I/O		PB0	ADC_IN8/TIM3_CH3 <sup>(8)</sup>	
19	27	36	16	PB1	I/O		PB1	ADC_IN9/TIM3_CH4 <sup>(8)</sup>	
20	28	37	17	PB2/BOOT1	I/O	FT	PB2/BOOT1		
-	-	38	-	PE7	I/O	FT	PE7		
-	-	39	-	PE8	I/O	FT	PE8		
-	-	40	-	PE9	I/O	FT	PE9		
-	-	41	-	PE10	I/O	FT	PE10		
-	-	42	-	PE11	I/O	FT	PE11		
-	-	43	-	PE12	I/O	FT	PE12		
-	-	44	-	PE13	I/O	FT	PE13		
-	-	45	-	PE14	I/O	FT	PE14		
-	-	46	-	PE15	I/O	FT	PE15		
21	29	47	-	PB10	I/O	FT	PB10	I2C2_SCL <sup>(6)</sup> / USART3_TX <sup>(6)</sup> (8)	TIM2_CH3
22	30	48	-	PB11	I/O	FT	PB11	I2C2_SDA <sup>(6)</sup> / USART3_RX <sup>(6)</sup> (8)	TIM2_CH4
23	31	49	18	V <sub>SS_1</sub>	S		V <sub>SS_1</sub>		
24	32	50	19	V <sub>DD_1</sub>	S		V <sub>DD_1</sub>		
25	33	51	-	PB12	I/O	FT	PB12	SPI2_NSS <sup>(6)</sup> (8)/ I2C2_SMBAL <sup>(6)</sup> / USART3_CK <sup>(6)</sup> (8)	
26	34	52	-	PB13	I/O	FT	PB13	SPI2_SCK <sup>(6)</sup> (8)/ USART3_CTS <sup>(6)</sup> (8)	
27	35	53	-	PB14	I/O	FT	PB14	SPI2_MISO <sup>(6)</sup> (8)/ USART3_RTS <sup>(6)</sup> (8)	

Table 4. Medium-density STM32F101xx pin definitions (continued)

Pins				Pin name	Type <sup>(1)</sup>	I / O level <sup>(2)</sup>	Main function <sup>(3)</sup> (after reset)	Alternate functions <sup>(3)</sup>		
LQFP48	LQFP64	LQFP100	VFQFPN36					Default	Remap	
28	36	54	-	PB15	I/O	FT	PB15	SPI2_MOSI <sup>(6)</sup> <sup>(8)</sup>		
-	-	55	-	PD8	I/O	FT	PD8		USART3_TX	
-	-	56	-	PD9	I/O	FT	PD9		USART3_RX	
-	-	57	-	PD10	I/O	FT	PD10		USART3_CK	
-	-	58	-	PD11	I/O	FT	PD11		USART3_CTS	
-	-	59	-	PD12	I/O	FT	PD12		TIM4_CH1 / USART3_RTS	
-	-	60	-	PD13	I/O	FT	PD13		TIM4_CH2	
-	-	61	-	PD14	I/O	FT	PD14		TIM4_CH3	
-	-	62	-	PD15	I/O	FT	PD15		TIM4_CH4	
-	37	63	-	PC6	I/O	FT	PC6		TIM3_CH1	
	38	64	-	PC7	I/O	FT	PC7		TIM3_CH2	
	39	65	-	PC8	I/O	FT	PC8		TIM3_CH3	
-	40	66	-	PC9	I/O	FT	PC9		TIM3_CH4	
29	41	67	20	PA8	I/O	FT	PA8	USART1_CK/MCO		
30	42	68	21	PA9	I/O	FT	PA9	USART1_TX <sup>(8)</sup>		
31	43	69	22	PA10	I/O	FT	PA10	USART1_RX <sup>(8)</sup>		
32	44	70	23	PA11	I/O	FT	PA11	USART1_CTS		
33	45	71	24	PA12	I/O	FT	PA12	USART1_RTS		
34	46	72	25	PA13/JTMS/SWDIO	I/O	FT	JTMS-SWDIO	PA13		
-	-	73	-	Not connected						
35	47	74	26	V <sub>SS_2</sub>	S		V <sub>SS_2</sub>			
36	48	75	27	V <sub>DD_2</sub>	S		V <sub>DD_2</sub>			
37	49	76	28	PA14/JTCK/SWCLK	I/O	FT	JTCK/SWCLK	PA14		
38	50	77	29	PA15/JTDI	I/O	FT	JTDI	PA15	TIM2_CH1_ETR/ SPI1_NSS	
-	51	78		PC10	I/O	FT	PC10		USART3_TX	
-	52	79		PC11	I/O	FT	PC11		USART3_RX	
-	53	80		PC12	I/O	FT	PC12		USART3_CK	
5	5	81	2	PD0	I/O	FT	OSC_IN <sup>(7)</sup>			
6	6	82	3	PD1	I/O	FT	OSC_OUT <sup>(7)</sup>			
	54	83	-	PD2	I/O	FT	PD2	TIM3_ETR		
-	-	84	-	PD3	I/O	FT	PD3		USART2_CTS	

Table 4. Medium-density STM32F101xx pin definitions (continued)

Pins				Pin name	Type <sup>(1)</sup>	I/O level <sup>(2)</sup>	Main function <sup>(3)</sup> (after reset)	Alternate functions <sup>(3)</sup>	
LQFP48	LQFP64	LQFP100	VFQFPN36					Default	Remap
-	-	85	-	PD4	I/O	FT	PD4		USART2_RTS
-	-	86	-	PD5	I/O	FT	PD5		USART2_TX
-	-	87	-	PD6	I/O	FT	PD6		USART2_RX
-	-	88	-	PD7	I/O	FT	PD7		USART2_CK
39	55	89	30	PB3/JTDO	I/O	FT	JTDO	PB3/TRACESWO	TIM2_CH2 / SPI1_SCK
40	56	90	31	PB4/JNTRST	I/O	FT	JNTRST	PB4	TIM3_CH1 / SPI1_MISO
41	57	91	32	PB5	I/O		PB5	I2C1_SMBAL	TIM3_CH2 / SPI1_MOSI
42	58	92	33	PB6	I/O	FT	PB6	I2C1_SCL <sup>(8)</sup> / TIM4_CH1 <sup>(6)</sup> (8)	USART1_TX
43	59	93	34	PB7	I/O	FT	PB7	I2C1_SDA <sup>(8)</sup> / TIM4_CH2 <sup>(6)</sup> (8)	USART1_RX
44	60	94	35	BOOT0	I		BOOT0		
45	61	95	-	PB8	I/O	FT	PB8	TIM4_CH3 <sup>(6)</sup> (8)	I2C1_SCL
46	62	96	-	PB9	I/O	FT	PB9	TIM4_CH4 <sup>(6)</sup> (8)	I2C1_SDA
-	-	97	-	PE0	I/O	FT	PE0	TIM4_ETR <sup>(6)</sup>	
-	-	98	-	PE1	I/O	FT	PE1		
47	63	99	36	V <sub>SS_3</sub>	S		V <sub>SS_3</sub>		
48	64	100	1	V <sub>DD_3</sub>	S		V <sub>DD_3</sub>		

1. I = input, O = output, S = supply, HiZ= high impedance.
2. FT= 5 V tolerant.
3. Function availability depends on the chosen device. For devices having reduced peripheral counts, it is always the lower number of peripherals that is included. For example, if a device has only one SPI, two USARTs and two timers, they will be called SPI1, USART1 & USART2 and TIM2 & TIM 3, respectively. Refer to [Table 2 on page 8](#).
4. PC13, PC14 and PC15 are supplied through the power switch, and so their use in output mode is limited: they can be used only in output 2 MHz mode with a maximum load of 30 pF and only one pin can be put in output mode at a time.
5. Main function after the first backup domain power-up. Later on, it depends on the contents of the Backup registers even after reset (because these registers are not reset by the main reset). For details on how to manage these IOs, refer to the Battery backup domain and BKP register description sections in the STM32F10xxx reference manual, available from the STMicroelectronics website: [www.st.com](http://www.st.com).
6. Available only on devices with a Flash memory density equal or higher than 64 Kbytes.
7. The pins number 2 and 3 in the VFQFPN36 package, and 5 and 6 in the LQFP48 and LQFP64 packages are configured as OSC\_IN/OSC\_OUT after reset, however the functionality of PD0 and PD1 can be remapped by software on these pins. For the LQFP100 package, PD0 and PD1 are available by default, so there is no need for remapping. For more details, refer to the Alternate function I/O and debug configuration section in the STM32F10xxx reference manual. The use of PD0 and PD1 in output mode is limited as they can only be used at 50 MHz in output mode.
8. This alternate function can be remapped by software to some other port pins (if available on the used package). For more details, refer to the Alternate function I/O and debug configuration section in the STM32F10xxx reference manual, available from the STMicroelectronics website: [www.st.com](http://www.st.com).

# 4 Memory mapping

The memory map is shown in *Figure 7*.

**Figure 7. Memory map**

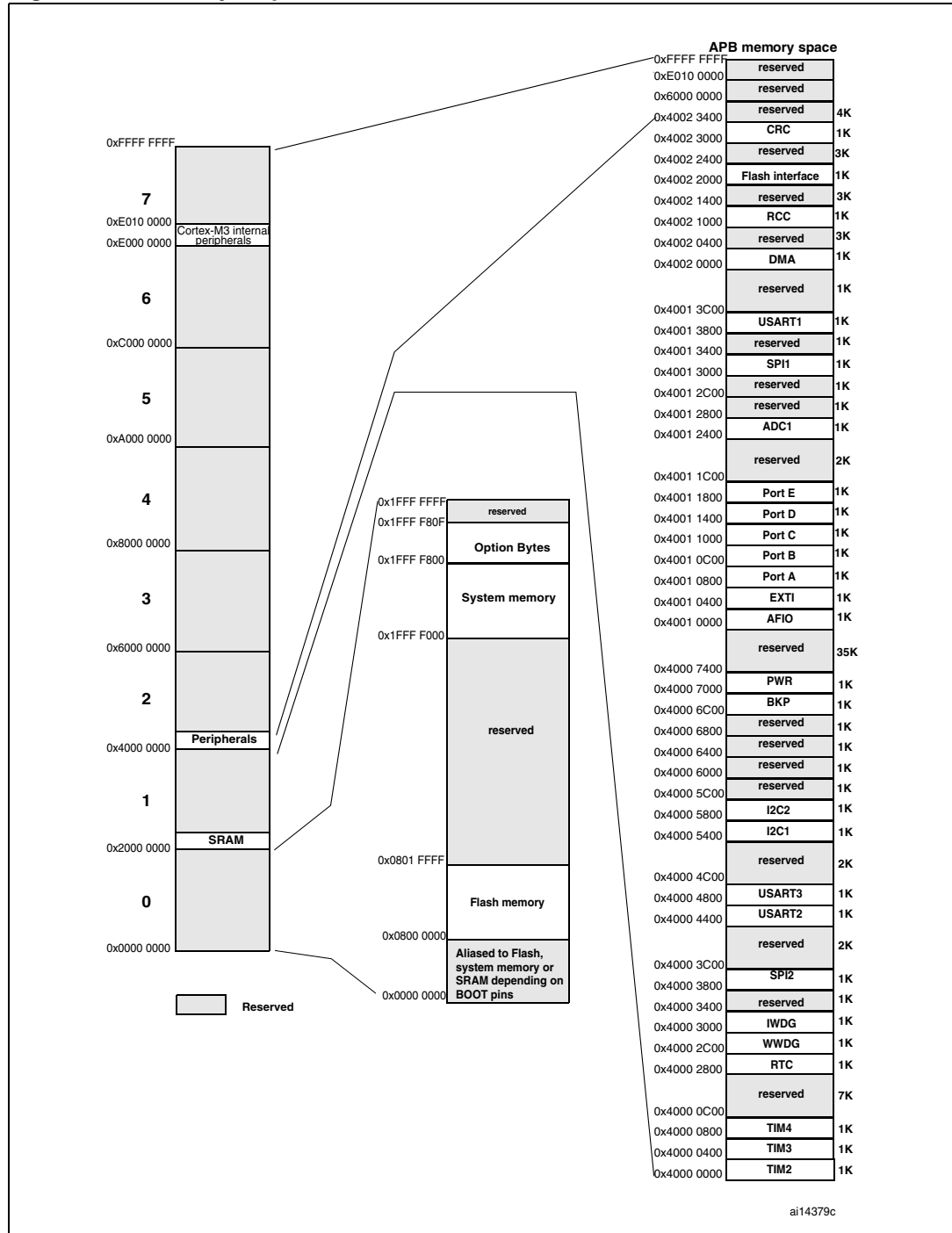

## 5 Electrical characteristics

### 5.1 Test conditions

Unless otherwise specified, all voltages are referenced to  $V_{SS}$ .

#### 5.1.1 Minimum and maximum values

Unless otherwise specified the minimum and maximum values are guaranteed in the worst conditions of ambient temperature, supply voltage and frequencies by tests in production on 100% of the devices with an ambient temperature at  $T_A = 25\text{ °C}$  and  $T_A = T_{A\text{max}}$  (given by the selected temperature range).

Data based on characterization results, design simulation and/or technology characteristics are indicated in the table footnotes and are not tested in production. Based on characterization, the minimum and maximum values refer to sample tests and represent the mean value plus or minus three times the standard deviation ( $\text{mean} \pm 3\Sigma$ ).

#### 5.1.2 Typical values

Unless otherwise specified, typical data are based on  $T_A = 25\text{ °C}$ ,  $V_{DD} = 3.3\text{ V}$  (for the  $2\text{ V} \leq V_{DD} \leq 3.6\text{ V}$  voltage range). They are given only as design guidelines and are not tested.

Typical ADC accuracy values are determined by characterization of a batch of samples from a standard diffusion lot over the full temperature range, where 95% of the devices have an error less than or equal to the value indicated ( $\text{mean} \pm 2\Sigma$ ).

#### 5.1.3 Typical curves

Unless otherwise specified, all typical curves are given only as design guidelines and are not tested.

#### 5.1.4 Loading capacitor

The loading conditions used for pin parameter measurement are shown in [Figure 8](#).

#### 5.1.5 Pin input voltage

The input voltage measurement on a pin of the device is described in [Figure 9](#).

Figure 8. Pin loading conditions

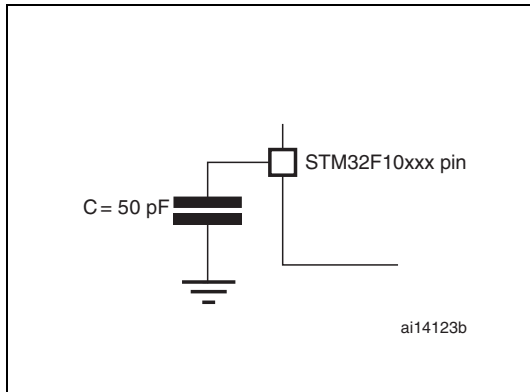
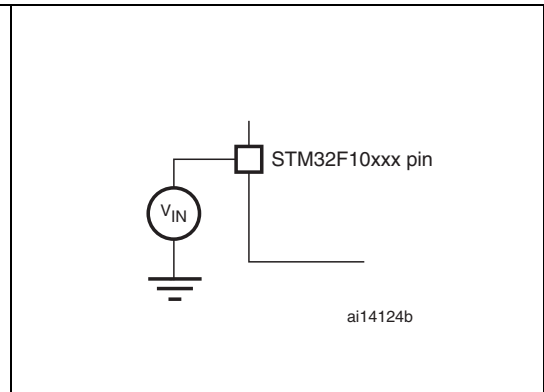
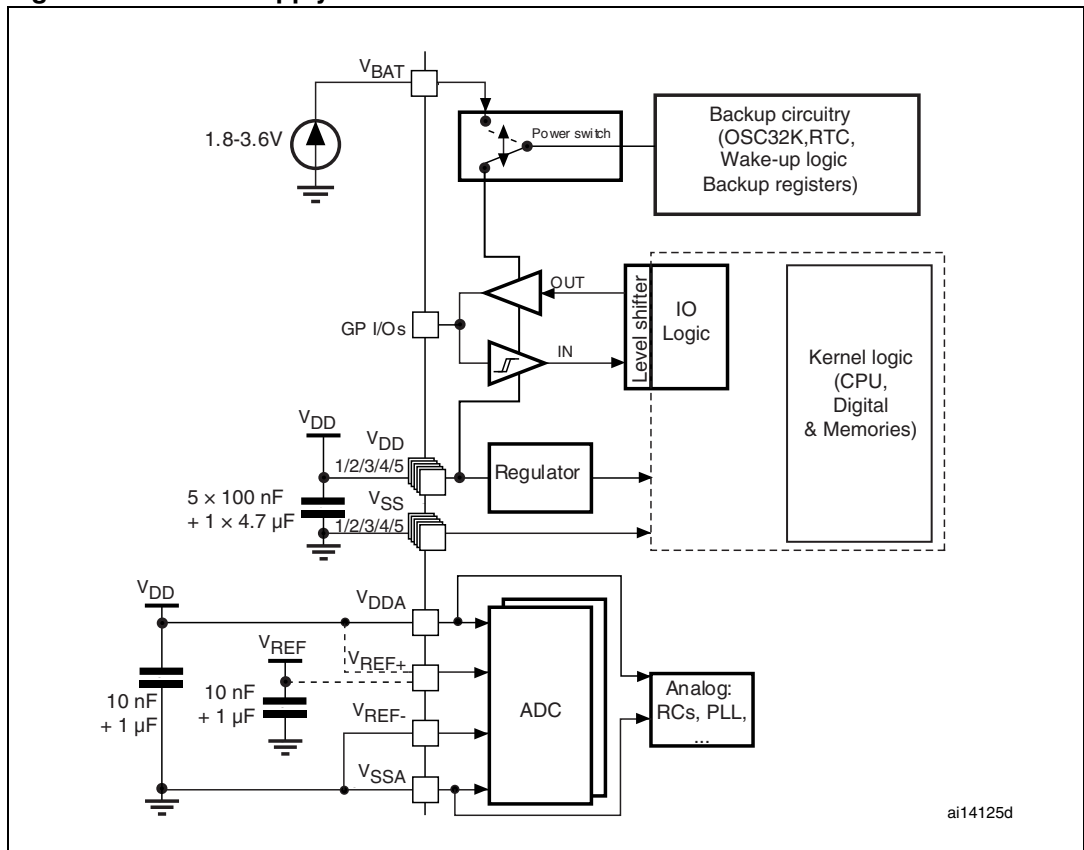

Figure 9. Pin input voltage



### 5.1.6 Power supply scheme

Figure 10. Power supply scheme



**Caution:** In [Figure 10](#), the 4.7  $\mu$ F capacitor must be connected to  $V_{DD3}$ .

### 5.1.7 Current consumption measurement

Figure 11. Current consumption measurement scheme

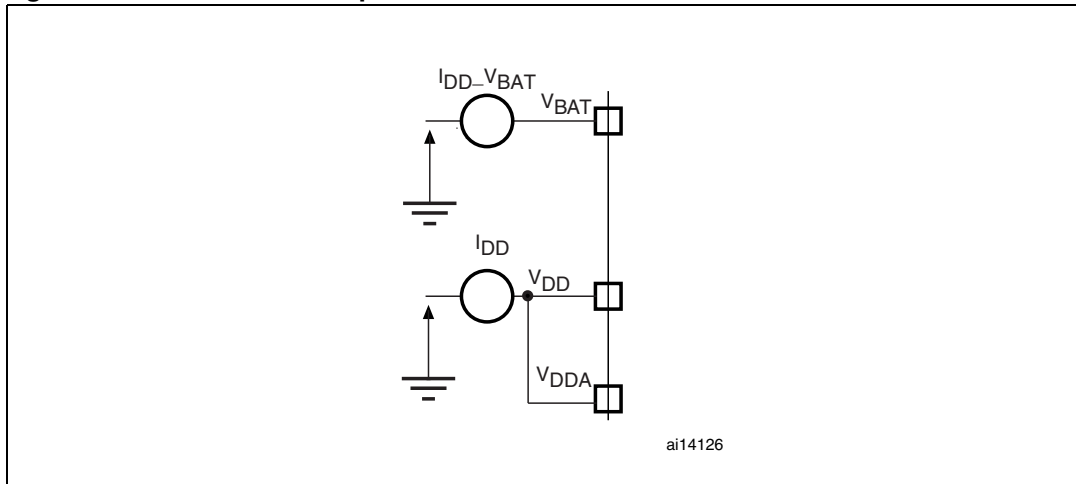

## 5.2 Absolute maximum ratings

Stresses above the absolute maximum ratings listed in [Table 5: Voltage characteristics](#), [Table 6: Current characteristics](#), and [Table 7: Thermal characteristics](#) may cause permanent damage to the device. These are stress ratings only and functional operation of the device at these conditions is not implied. Exposure to maximum rating conditions for extended periods may affect device reliability.

Table 5. Voltage characteristics

Symbol	Ratings	Min	Max	Unit
$V_{DD} - V_{SS}$	External main supply voltage (including $V_{DDA}$ and $V_{DD}$ ) <sup>(1)</sup>	-0.3	4.0	V
$V_{IN}$	Input voltage on five volt tolerant pin <sup>(2)</sup>	$V_{SS} - 0.3$	+5.5	
	Input voltage on any other pin <sup>(2)</sup>	$V_{SS} - 0.3$	$V_{DD} + 0.3$	
$ \Delta V_{DDx} $	Variations between different power pins	50	50	mV
$ V_{SSx} - V_{SS} $	Variations between all the different ground pins	50	50	
$V_{ESD(HBM)}$	Electrostatic discharge voltage (human body model)	see <a href="#">Section 5.3.11: Absolute maximum ratings (electrical sensitivity)</a>		

1. All main power ( $V_{DD}$ ,  $V_{DDA}$ ) and ground ( $V_{SS}$ ,  $V_{SSA}$ ) pins must always be connected to the external power supply, in the permitted range.
2.  $I_{INJ(PIN)}$  must never be exceeded (see [Table 6: Current characteristics](#)). This is implicitly insured if  $V_{IN}$  maximum is respected. If  $V_{IN}$  maximum cannot be respected, the injection current must be limited externally to the  $I_{INJ(PIN)}$  value. A positive injection is induced by  $V_{IN} > V_{DD}$  while a negative injection is induced by  $V_{IN} < V_{SS}$ .

**Table 6. Current characteristics**

Symbol	Ratings	Max.	Unit
$I_{VDD}$	Total current into $V_{DD}$ power lines (source) <sup>(1)</sup>	150	mA
$I_{VSS}$	Total current out of $V_{SS}$ ground lines (sink) <sup>(1)</sup>	150	
$I_{IO}$	Output current sunk by any I/O and control pin	25	
	Output current source by any I/Os and control pin	- 25	
$I_{INJ(PIN)}$ <sup>(2)(3)</sup>	Injected current on NRST pin	± 5	
	Injected current on High-speed external OSC_IN and Low-speed external OSC_IN pins	± 5	
	Injected current on any other pin <sup>(4)</sup>	± 5	
$\Sigma I_{INJ(PIN)}$ <sup>(2)</sup>	Total injected current (sum of all I/O and control pins) <sup>(4)</sup>	± 25	

1. All main power ( $V_{DD}$ ,  $V_{DDA}$ ) and ground ( $V_{SS}$ ,  $V_{SSA}$ ) pins must always be connected to the external power supply, in the permitted range.
2.  $I_{INJ(PIN)}$  must never be exceeded. This is implicitly insured if  $V_{IN}$  maximum is respected. If  $V_{IN}$  maximum cannot be respected, the injection current must be limited externally to the  $I_{INJ(PIN)}$  value. A positive injection is induced by  $V_{IN} > V_{DD}$  while a negative injection is induced by  $V_{IN} < V_{SS}$ .
3. Negative injection disturbs the analog performance of the device. See note in [Section 5.3.16: 12-bit ADC characteristics](#).
4. When several inputs are submitted to a current injection, the maximum  $\Sigma I_{INJ(PIN)}$  is the absolute sum of the positive and negative injected currents (instantaneous values). These results are based on characterization with  $\Sigma I_{INJ(PIN)}$  maximum current injection on four I/O port pins of the device.

**Table 7. Thermal characteristics**

Symbol	Ratings	Value	Unit
$T_{STG}$	Storage temperature range	?-65 to +150	°C
$T_J$	Maximum junction temperature	150	°C

## 5.3 Operating conditions

### 5.3.1 General operating conditions

**Table 8. General operating conditions**

Symbol	Parameter	Conditions	Min	Max	Unit
$f_{HCLK}$	Internal AHB clock frequency		0	36	MHz
$f_{PCLK1}$	Internal APB1 clock frequency		0	36	
$f_{PCLK2}$	Internal APB2 clock frequency		0	36	
$V_{DD}$	Standard operating voltage		2	3.6	V
$V_{DDA}$ <sup>(1)</sup>	Analog operating voltage (ADC not used)	Must be the same potential as $V_{DD}$	2	3.6	V
	Analog operating voltage (ADC used)		2.4	3.6	
$V_{BAT}$	Backup operating voltage		1.8	3.6	V

**Table 8. General operating conditions (continued)**

Symbol	Parameter	Conditions	Min	Max	Unit
P <sub>D</sub>	Power dissipation at T <sub>A</sub> = 85 °C <sup>(2)</sup>	LQFP100		434	mW
		LQFP64		444	
		LQFP48		363	
		VFQFPN36		1110	
T <sub>A</sub>	Ambient temperature	Maximum power dissipation	-40	85	°C
		Low power dissipation <sup>(3)</sup>	-40	105	°C
T <sub>J</sub>	Junction temperature range		-40	105	°C

1. When the ADC is used, refer to [Table 41: ADC characteristics](#).
2. If T<sub>A</sub> is lower, higher P<sub>D</sub> values are allowed as long as T<sub>J</sub> does not exceed T<sub>J</sub>max (see [Table 6.2: Thermal characteristics on page 68](#)).
3. In low power dissipation state, T<sub>A</sub> can be extended to this range as long as T<sub>J</sub> does not exceed T<sub>J</sub>max (see [Table 6.2: Thermal characteristics on page 68](#)).

### 5.3.2 Operating conditions at power-up / power-down

Subject to general operating conditions for T<sub>A</sub>.

**Table 9. Operating conditions at power-up / power-down**

Symbol	Parameter	Conditions	Min	Max	Unit
t <sub>VDD</sub>	V <sub>DD</sub> rise time rate		0	∞	μs/V
	V <sub>DD</sub> fall time rate		20	∞	

### 5.3.3 Embedded reset and power control block characteristics

The parameters given in [Table 10](#) are derived from tests performed under the ambient temperature and V<sub>DD</sub> supply voltage conditions summarized in [Table 8](#).

Table 10. Embedded reset and power control block characteristics

Symbol	Parameter	Conditions	Min	Typ	Max	Unit
$V_{PVD}$	Programmable voltage detector level selection	PLS[2:0]=000 (rising edge)	2.1	2.18	2.26	V
		PLS[2:0]=000 (falling edge)	2	2.08	2.16	V
		PLS[2:0]=001 (rising edge)	2.19	2.28	2.37	V
		PLS[2:0]=001 (falling edge)	2.09	2.18	2.27	V
		PLS[2:0]=010 (rising edge)	2.28	2.38	2.48	V
		PLS[2:0]=010 (falling edge)	2.18	2.28	2.38	V
		PLS[2:0]=011 (rising edge)	2.38	2.48	2.58	V
		PLS[2:0]=011 (falling edge)	2.28	2.38	2.48	V
		PLS[2:0]=100 (rising edge)	2.47	2.58	2.69	V
		PLS[2:0]=100 (falling edge)	2.37	2.48	2.59	V
		PLS[2:0]=101 (rising edge)	2.57	2.68	2.79	V
		PLS[2:0]=101 (falling edge)	2.47	2.58	2.69	V
		PLS[2:0]=110 (rising edge)	2.66	2.78	2.9	V
		PLS[2:0]=110 (falling edge)	2.56	2.68	2.8	V
		PLS[2:0]=111 (rising edge)	2.76	2.88	3	V
		PLS[2:0]=111 (falling edge)	2.66	2.78	2.9	V
$V_{PVDhyst}^{(2)}$	PVD hysteresis			100		mV
$V_{POR/PDR}$	Power on/power down reset threshold	Falling edge	1.8 <sup>(1)</sup>	1.88	1.96	V
		Rising edge	1.84	1.92	2.0	V
$V_{PDRhyst}^{(2)}$	PDR hysteresis			40		mV
$t_{RSTTEMPO}^{(2)}$	Reset temporization		1.5	2.5	4.5	ms

1. The product behavior is guaranteed by design down to the minimum  $V_{POR/PDR}$  value.

2. Guaranteed by design, not tested in production.

### 5.3.4 Embedded reference voltage

The parameters given in [Table 11](#) are derived from tests performed under the ambient temperature and  $V_{DD}$  supply voltage conditions summarized in [Table 8](#).

**Table 11. Embedded internal reference voltage**

Symbol	Parameter	Conditions	Min	Typ	Max	Unit
$V_{REFINT}$	Internal reference voltage	$-40\text{ °C} < T_A < +85\text{ °C}$	1.16	1.20	1.24	V
$T_{S\_vrefint}^{(1)}$	ADC sampling time when reading the internal reference voltage			5.1	17.1 <sup>(2)</sup>	$\mu\text{s}$

1. Shortest sampling time can be determined in the application by multiple iterations.
2. Guaranteed by design, not tested in production.

### 5.3.5 Supply current characteristics

The current consumption is measured as described in [Figure 11: Current consumption measurement scheme](#).

#### Maximum current consumption

The MCU is placed under the following conditions:

- All I/O pins are in input mode with a static value at  $V_{DD}$  or  $V_{SS}$  (no load)
- All peripherals are disabled except if it is explicitly mentioned
- The Flash access time is adjusted to  $f_{HCLK}$  frequency (0 wait state from 0 to 24 MHz, 1 wait state from 24 to 36 MHz)
- Prefetch in on (reminder: this bit must be set before clock setting and bus prescaling)
- When the peripherals are enabled  $f_{PCLK1} = f_{HCLK}/2$ ,  $f_{PCLK2} = f_{HCLK}$

The parameters given in [Table 12](#) are derived from tests performed under the ambient temperature and  $V_{DD}$  supply voltage conditions summarized in [Table 8](#).

**Table 12. Maximum current consumption in Run mode, code with data processing running from Flash**

Symbol	Parameter	Conditions	$f_{HCLK}$	Max <sup>(1)</sup>	Unit
				$T_A = 85\text{ °C}$	
$I_{DD}$	Supply current in Run mode	External clock <sup>(2)</sup> , all peripherals enabled	36 MHz	28.6	mA
			24 MHz	19.9	
			16 MHz	14.7	
			8 MHz	8.6	
		External clock <sup>(3)</sup> , all peripherals Disabled	36 MHz	19.8	
			24 MHz	13.9	
			16 MHz	10.7	
			8 MHz	6.8	

1. Based on characterization, tested in production at  $V_{DD}$  max,  $f_{HCLK}$  max.
2. External clock is 8 MHz and PLL is on when  $f_{HCLK} > 8\text{ MHz}$ .

**Table 13. Maximum current consumption in Run mode, code with data processing running from RAM**

Symbol	Parameter	Conditions	f <sub>HCLK</sub>	Max <sup>(1)</sup>	Unit
				T <sub>A</sub> = 85 °C	
I <sub>DD</sub>	Supply current in Run mode	External clock <sup>(2)</sup> , all peripherals enabled	36 MHz	24	mA
			24 MHz	17.5	
			16 MHz	12.5	
			8 MHz	7.5	
		External clock <sup>(2)</sup> all peripherals disabled	36 MHz	16	
			24 MHz	11.5	
			16 MHz	8.5	
			8 MHz	5.5	

1. Based on characterization, tested in production at V<sub>DD</sub> max, f<sub>HCLK</sub> max.
2. External clock is 8 MHz and PLL is on when f<sub>HCLK</sub> > 8 MHz.

**Figure 12. Typical current consumption in Run mode versus frequency (at 3.6 V) - code with data processing running from RAM, peripherals enabled**

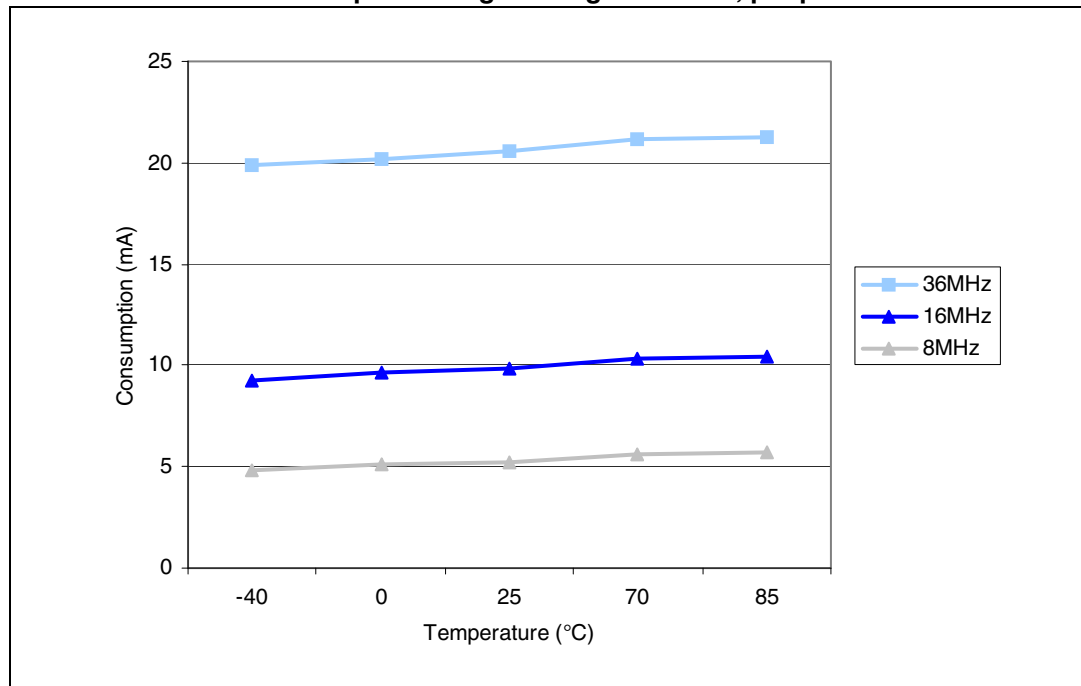

**Figure 13. Typical current consumption in Run mode versus frequency (at 3.6 V) - code with data processing running from RAM, peripherals disabled**

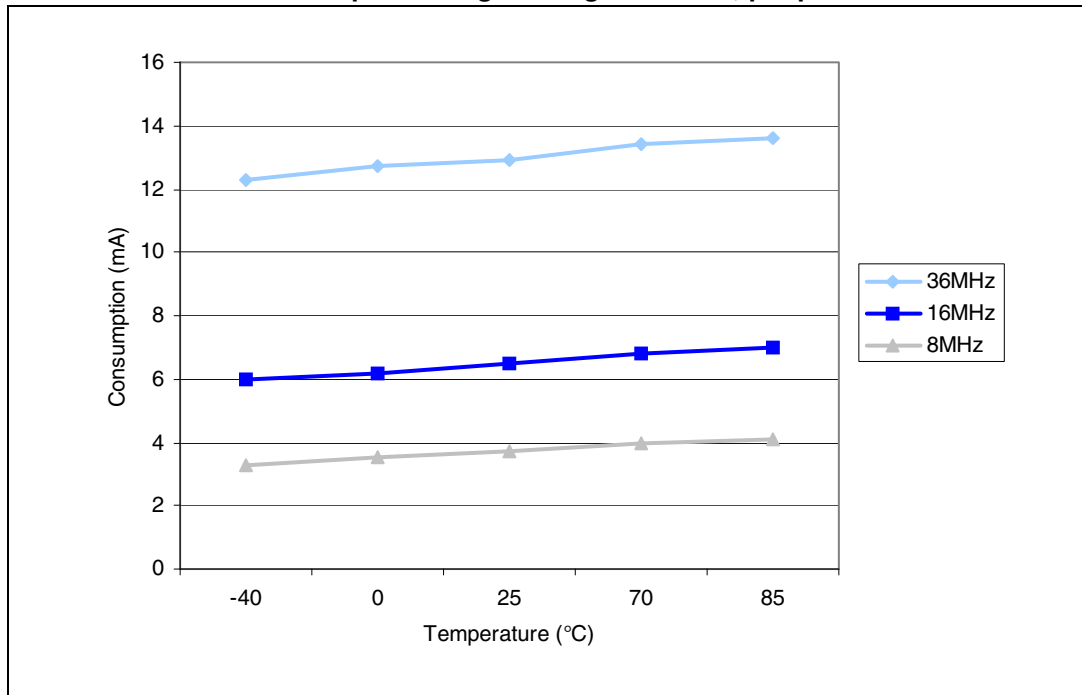

**Table 14. Maximum current consumption in Sleep mode, code running from Flash or RAM**

Symbol	Parameter	Conditions	f <sub>HCLK</sub>	Max <sup>(1)</sup>	Unit
				T <sub>A</sub> = 85 °C	
I <sub>DD</sub>	Supply current in Sleep mode	External clock <sup>(2)</sup> all peripherals enabled	36 MHz	15.5	mA
			24 MHz	11.5	
			16 MHz	8.5	
			8 MHz	5.5	
		External clock <sup>(2)</sup> , all peripherals disabled	36 MHz	5	
			24 MHz	4.5	
			16 MHz	4	
			8 MHz	3	

1. Data based on characterization results, tested in production at V<sub>DD</sub> max, f<sub>HCLK</sub> max.

2. External clock is 8 MHz and PLL is on when f<sub>HCLK</sub> > 8 MHz.

**Table 15. Typical and maximum current consumptions in Stop and Standby modes**

Symbol	Parameter	Conditions	Typ <sup>(1)</sup>		Max	Unit
			V <sub>DD</sub> /V <sub>BAT</sub> = 2.4 V	V <sub>DD</sub> /V <sub>BAT</sub> = 3.3 V	T <sub>A</sub> = 85 °C <sup>(2)</sup>	
I <sub>DD</sub>	Supply current in Stop mode	Regulator in Run mode, Low-speed and high-speed internal RC oscillators and high-speed oscillator OFF (no independent watchdog)	23.5	24	200	µA
		Regulator in Low-Power mode, Low-speed and high-speed internal RC oscillators and high-speed oscillator OFF (no independent watchdog)	13.5	14	180	
	Supply current in Standby mode	Low-speed internal RC oscillator and independent watchdog ON	2.6	3.4	-	
		Low-speed internal RC oscillator ON, independent watchdog OFF	2.4	3.2	-	
		Low-speed internal RC oscillator and independent watchdog OFF, low-speed oscillator and RTC OFF	1.7	2	3.2	
I <sub>DD_VBAT</sub>	Backup domain supply current	Low-speed oscillator and RTC ON	1.1	1.4	1.9	

1. Typical values are measured at T<sub>A</sub> = 25 °C.
2. Based on characterization, not rested in production.

**Figure 14. Current consumption in Stop mode with regulator in Run mode versus temperature at V<sub>DD</sub> = 3.3 V and 3.6 V**

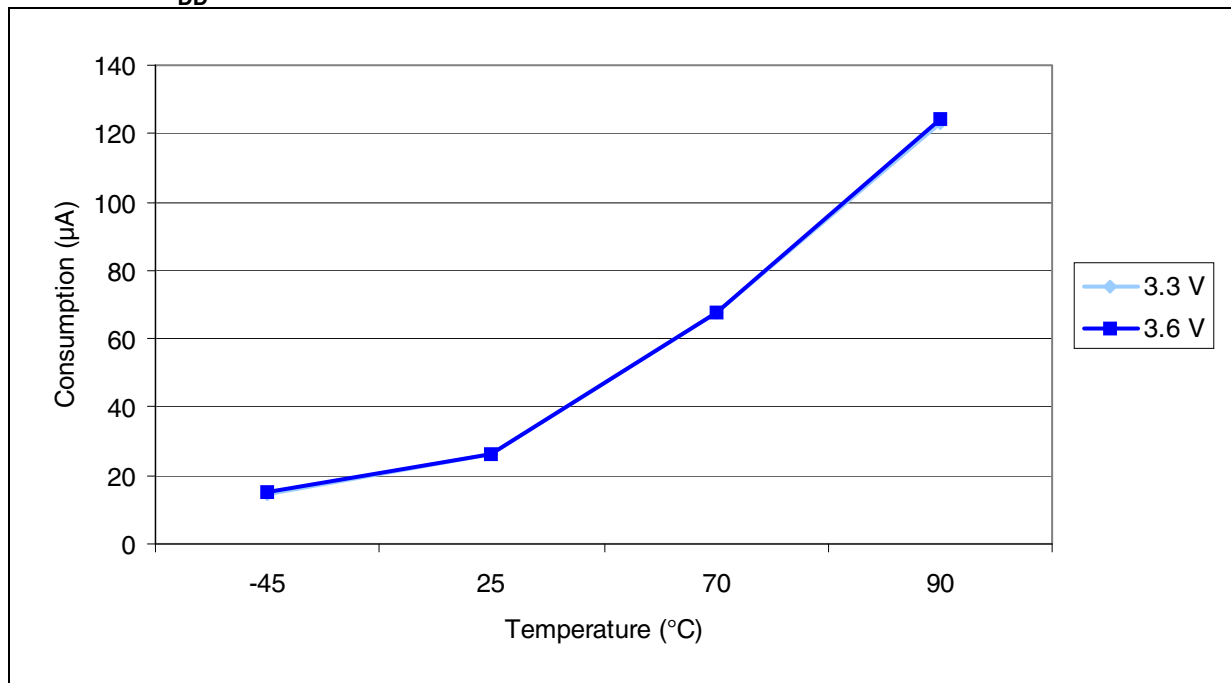

Figure 15. Current consumption in Stop mode with regulator in Low-power mode versus temperature at  $V_{DD} = 3.3\text{ V}$  and  $3.6\text{ V}$

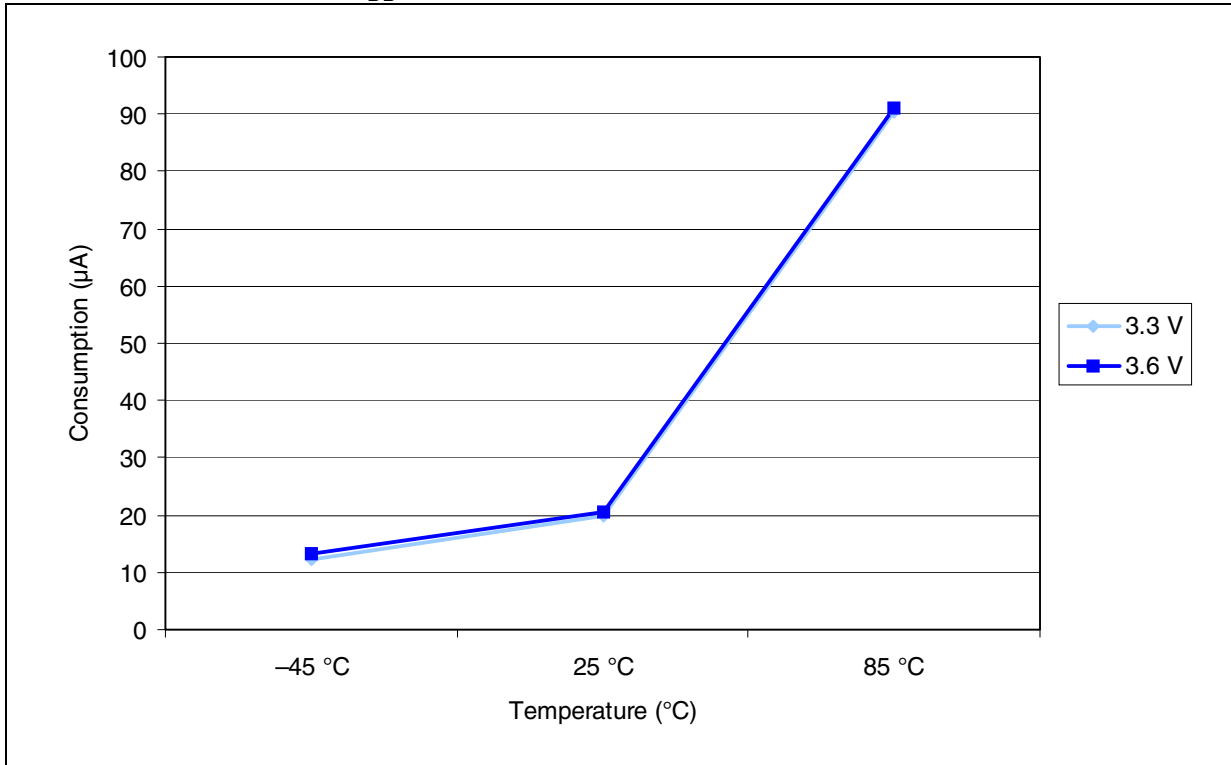
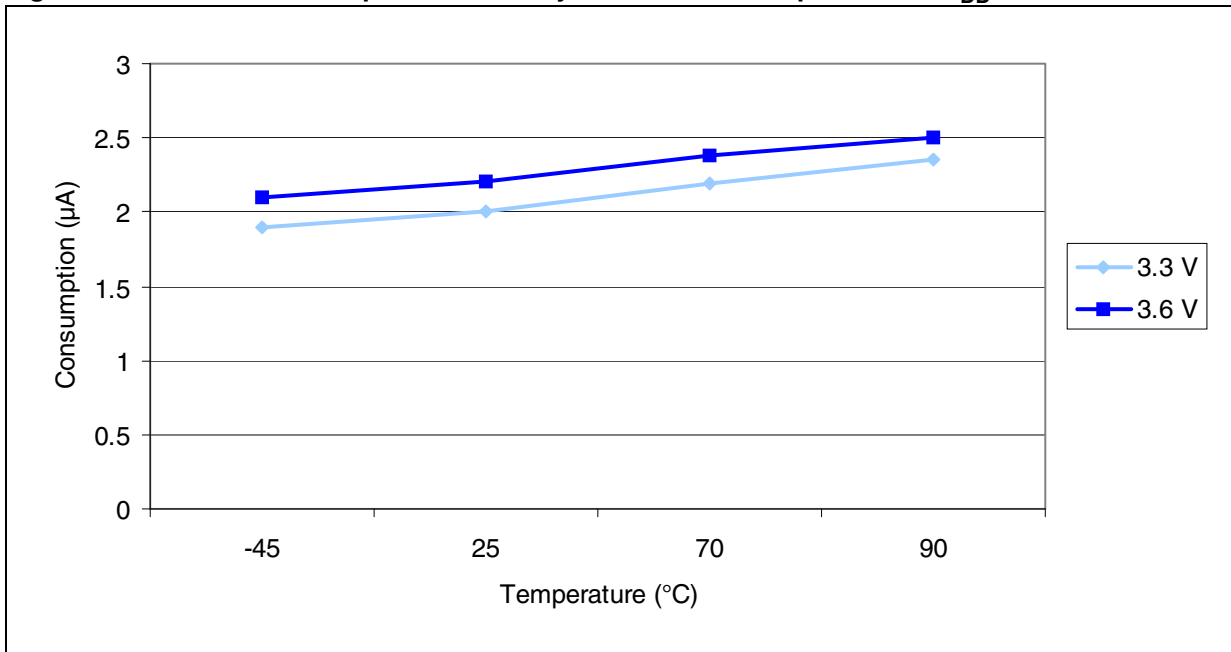

Figure 16. Current consumption in Standby mode versus temperature at  $V_{DD} = 3.3\text{ V}$  and  $3.6\text{ V}$



**Typical current consumption**

The MCU is placed under the following conditions:

- All I/O pins are in input mode with a static value at V<sub>DD</sub> or V<sub>SS</sub> (no load)
- All peripherals are disabled except if it is explicitly mentioned
- The Flash access time is adjusted to f<sub>HCLK</sub> frequency (0 wait state from 0 to 24 MHz, 1 wait state from 24 to 36 MHz)
- Prefetch is on (reminder: this bit must be set before clock setting and bus prescaling)
- When the peripherals are enabled f<sub>PCLK1</sub> = f<sub>HCLK</sub>/4, f<sub>PCLK2</sub> = f<sub>HCLK</sub>/2, f<sub>ADCCLK</sub> = f<sub>PCLK2</sub>/4

The parameters given in [Table 16](#) are derived from tests performed under the ambient temperature and V<sub>DD</sub> supply voltage conditions summarized in [Table 8](#).

**Table 16. Typical current consumption in Run mode, code with data processing running from Flash**

Symbol	Parameter	Conditions	f <sub>HCLK</sub>	Typ <sup>(1)</sup>		Unit
				All peripherals enabled <sup>(2)</sup>	All peripherals disabled	
I <sub>DD</sub>	Supply current in Run mode	External clock <sup>(3)</sup>	36 MHz	19	14.8	mA
			24 MHz	12.9	10.1	
			16 MHz	9.3	7.4	
			8 MHz	5.5	4.6	
			4 MHz	3.3	2.8	
			2 MHz	2.2	1.9	
			1 MHz	1.6	1.45	
			500 kHz	1.3	1.25	
		125 kHz	1.08	1.06		
		Running on high speed internal RC (HSI), AHB prescaler used to reduce the frequency	36 MHz	18.3	14.1	
			24 MHz	12.2	9.5	
			16 MHz	8.5	6.8	
			8 MHz	4.9	4	
			4 MHz	2.7	2.2	
			2 MHz	1.6	1.4	
			1 MHz	1.02	0.9	
500 kHz	0.73		0.67			
125 kHz	0.5	0.48				

1. Typical values are measures at T<sub>A</sub> = 25 °C, V<sub>DD</sub> = 3.3 V.
2. Add an additional power consumption of 0.8 mA per ADC for the analog part. In applications, this consumption occurs only while the ADC is on (ADON bit is set in the ADC\_CR2 register).
3. External clock is 8 MHz and PLL is on when f<sub>HCLK</sub> > 8 MHz.

**Table 17. Typical current consumption in Sleep mode, code with data processing code running from Flash or RAM**

Symbol	Parameter	Conditions	f <sub>HCLK</sub>	Typ <sup>(1)</sup>		Unit
				All peripherals enabled <sup>(2)</sup>	All peripherals disabled	
I <sub>DD</sub>	Supply current in Sleep mode	External clock <sup>(3)</sup>	36 MHz	7.6	3.1	mA
			24 MHz	5.3	2.3	
			16 MHz	3.8	1.8	
			8 MHz	2.1	1.2	
			4 MHz	1.6	1.1	
			2 MHz	1.3	1	
			1 MHz	1.11	0.98	
			500 kHz	1.04	0.96	
			125 kHz	0.98	0.95	
		Running on High Speed Internal RC (HSI), AHB prescaler used to reduce the frequency	36 MHz	7	2.5	
			24 MHz	4.8	1.8	
			16 MHz	3.2	1.2	
			8 MHz	1.6	0.6	
			4 MHz	1	0.5	
			2 MHz	0.72	0.47	
			1 MHz	0.56	0.44	
			500 kHz	0.49	0.42	
			125 kHz	0.43	0.41	

1. Typical values are measures at T<sub>A</sub> = 25 °C, V<sub>DD</sub> = 3.3 V.
2. Add an additional power consumption of 0.8 mA per ADC for the analog part. In applications, this consumption occurs only while the ADC is on (ADON bit is set in the ADC\_CR2 register).
3. External clock is 8 MHz and PLL is on when f<sub>HCLK</sub> > 8 MHz.

### On-chip peripheral current consumption

The current consumption of the on-chip peripherals is given in [Table 18](#). The MCU is placed under the following conditions:

- all I/O pins are in input mode with a static value at  $V_{DD}$  or  $V_{SS}$  (no load)
- all peripherals are disabled unless otherwise mentioned
- the given value is calculated by measuring the current consumption
  - with all peripherals clocked off
  - with only one peripheral clocked on
- ambient operating temperature and  $V_{DD}$  supply voltage conditions summarized in [Table 5](#).

**Table 18. Peripheral current consumption**

Peripheral		Typical consumption at 25 °C <sup>(1)</sup>	Unit
APB1	TIM2	0.6	mA
	TIM3	0.6	
	TIM4	0.6	
	SPI2	0.08	
	USART2	0.21	
	USART3	0.21	
	I2C1	0.18	
	I2C2	0.18	
APB2	GPIO A	0.21	
	GPIO B	0.21	
	GPIO C	0.21	
	GPIO D	0.21	
	GPIO E	0.21	
	ADC1 <sup>(2)</sup>	1.4	
	SPI1	0.24	
	USART1	0.35	

1.  $f_{HCLK} = 36$  MHz,  $f_{APB1} = f_{HCLK}/2$ ,  $f_{APB2} = f_{HCLK}$ , default prescaler value for each peripheral.

2. Specific conditions for ADC:  $f_{HCLK} = 28$  MHz,  $f_{APB1} = f_{HCLK}/2$ ,  $f_{APB2} = f_{HCLK}$ ,  $f_{ADCLK} = f_{APB2}/2$ , ADON bit in the ADC\_CR2 register is set to 1.

### 5.3.6 External clock source characteristics

#### High-speed external user clock generated from an external source

The characteristics given in [Table 19](#) result from tests performed using an high-speed external clock source, and under the ambient temperature and supply voltage conditions summarized in [Table 8](#).

**Table 19. High-speed external user clock characteristics**

Symbol	Parameter	Conditions	Min	Typ	Max	Unit
$f_{HSE\_ext}$	User external clock source frequency <sup>(1)</sup>		0	8	25	MHz
$V_{HSEH}$	OSC_IN input pin high level voltage		$0.7V_{DD}$		$V_{DD}$	V
$V_{HSEL}$	OSC_IN input pin low level voltage		$V_{SS}$		$0.3V_{DD}$	
$t_{w(HSE)}$ $t_{w(HSE)}$	OSC_IN high or low time <sup>(1)</sup>		16			ns
$t_{r(HSE)}$ $t_{f(HSE)}$	OSC_IN rise or fall time <sup>(1)</sup>				5	
$I_L$	OSC_IN Input leakage current	$V_{SS} \leq V_{IN} \leq V_{DD}$			$\pm 1$	$\mu A$

1. Guaranteed by design, not tested in production.

**Low-speed external user clock generated from an external source**

The characteristics given in [Table 20](#) result from tests performed using an low-speed external clock source, and under the ambient temperature and supply voltage conditions summarized in [Table 8](#).

**Table 20. Low-speed external user clock characteristics**

Symbol	Parameter	Conditions	Min	Typ	Max	Unit
$f_{LSE\_ext}$	User external clock source frequency <sup>(1)</sup>			32.768	1000	kHz
$V_{LSEH}$	OSC32_IN input pin high level voltage		$0.7V_{DD}$		$V_{DD}$	V
$V_{LSEL}$	OSC32_IN input pin low level voltage		$V_{SS}$		$0.3V_{DD}$	
$t_{w(LSE)}$ $t_{w(LSE)}$	OSC32_IN high or low time <sup>(1)</sup>		450			ns
$t_{r(LSE)}$ $t_{f(LSE)}$	OSC32_IN rise or fall time <sup>(1)</sup>				5	
$I_L$	OSC32_IN Input leakage current	$V_{SS} \leq V_{IN} \leq V_{DD}$			$\pm 1$	$\mu A$

1. Guaranteed by design, not tested in production.

Figure 17. High-speed external clock source AC timing diagram

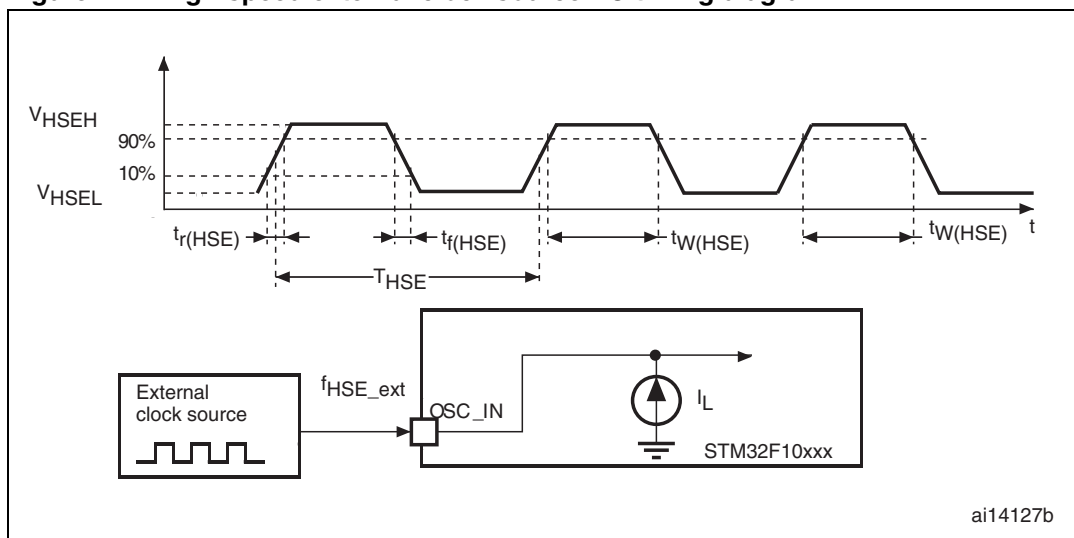
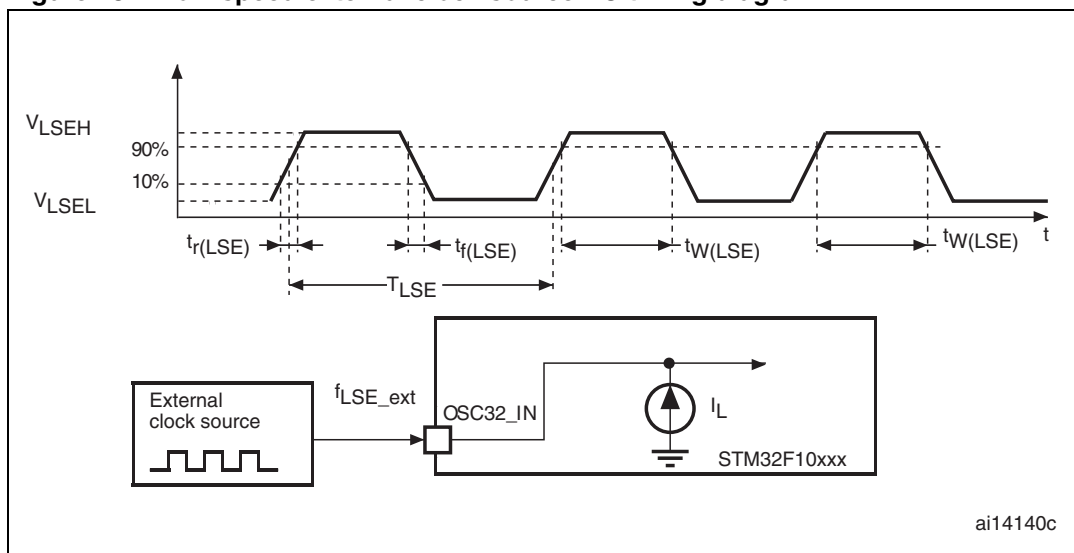

Figure 18. Low-speed external clock source AC timing diagram



**High-speed external clock generated from a crystal/ceramic resonator**

The high-speed external (HSE) clock can be supplied with a 4 to 16 MHz crystal/ceramic resonator oscillator. All the information given in this paragraph are based on characterization results obtained with typical external components specified in [Table 21](#). In the application, the resonator and the load capacitors have to be placed as close as possible to the oscillator pins in order to minimize output distortion and startup stabilization time. Refer to the crystal resonator manufacturer for more details on the resonator characteristics (frequency, package, accuracy).

**Table 21. HSE 4-16 MHz oscillator characteristics<sup>(1)(2)</sup>**

Symbol	Parameter	Conditions	Min	Typ	Max	Unit
$f_{OSC\_IN}$	Oscillator frequency		4	8	16	MHz
$R_F$	Feedback resistor			200		k $\Omega$
$C_{L1}$ $C_{L2}^{(3)}$	Recommended load capacitance versus equivalent serial resistance of the crystal ( $R_S$ ) <sup>(4)</sup>	$R_S = 30 \Omega$		30		pF
$i_2$	HSE driving current	$V_{DD} = 3.3 V$ $V_{IN} = V_{SS}$ with 30 pF load			1	mA
$g_m$	Oscillator transconductance	Startup	25			mA/V
$t_{SU(HSE)}^{(5)}$	Startup time	$V_{DD}$ is stabilized		2		ms

1. Resonator characteristics given by the crystal/ceramic resonator manufacturer.
2. Based on characterization, not tested in production.
3. For  $C_{L1}$  and  $C_{L2}$  it is recommended to use high-quality ceramic capacitors in the 5 pF to 25 pF range (typ.), designed for high-frequency applications, and selected to match the requirements of the crystal or resonator.  $C_{L1}$  and  $C_{L2}$  are usually the same size. The crystal manufacturer typically specifies a load capacitance which is the series combination of  $C_{L1}$  and  $C_{L2}$ . PCB and MCU pin capacitance must be included (10 pF can be used as a rough estimate of the combined pin and board capacitance) when sizing  $C_{L1}$  and  $C_{L2}$ .
4. The relatively low value of the RF resistor offers a good protection against issues resulting from use in a humid environment, due to the induced leakage and the bias condition change. However, it is recommended to take this point into account if the MCU is used in tough humidity conditions.
5.  $t_{SU(HSE)}$  is the startup time measured from the moment it is enabled (by software) to a stabilized 8 MHz oscillation is reached. This value is measured for a standard crystal resonator and it can vary significantly with the crystal manufacturer

**Figure 19. Typical application with an 8 MHz crystal**

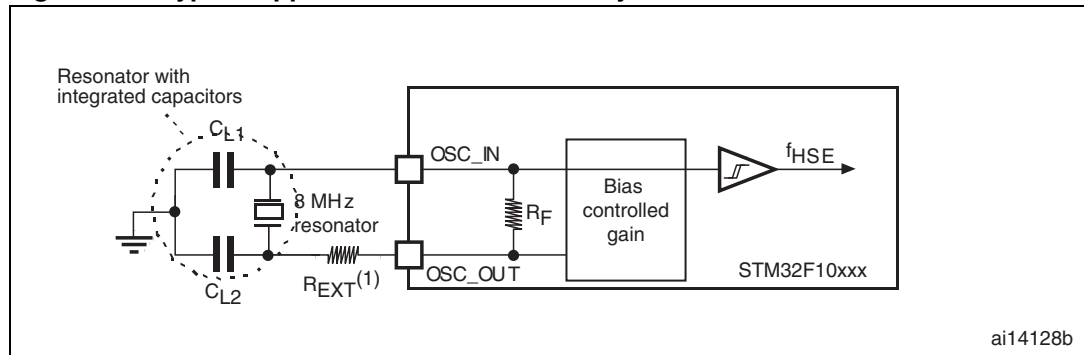

1.  $R_{EXT}$  value depends on the crystal characteristics. Typical value is in the range of 5 to 6 $R_S$ .

**Low-speed external clock generated from a crystal/ceramic resonator**

The low-speed external (LSE) clock can be supplied with a 32.768 kHz crystal/ceramic resonator oscillator. All the information given in this paragraph are based on characterization results obtained with typical external components specified in [Table 22](#). In the application, the resonator and the load capacitors have to be placed as close as possible to the oscillator pins in order to minimize output distortion and startup stabilization time. Refer to the crystal resonator manufacturer for more details on the resonator characteristics (frequency, package, accuracy).

**Note:** For  $C_{L1}$  and  $C_{L2}$  it is recommended to use high-quality ceramic capacitors in the 5 pF to 15 pF range selected to match the requirements of the crystal or resonator.  $C_{L1}$  and  $C_{L2}$  are usually the same size. The crystal manufacturer typically specifies a load capacitance which is the series combination of  $C_{L1}$  and  $C_{L2}$ .

Load capacitance  $C_L$  has the following formula:  $C_L = C_{L1} \times C_{L2} / (C_{L1} + C_{L2}) + C_{stray}$  where  $C_{stray}$  is the pin capacitance and board or trace PCB-related capacitance. Typically, it is between 2 pF and 7 pF.

**Caution:** To avoid exceeding the maximum value of  $C_{L1}$  and  $C_{L2}$  (15 pF) it is strongly recommended to use a resonator with a load capacitance  $C_L \leq 7$  pF. Never use a resonator with a load capacitance of 12.5 pF.

**Example:** if you choose a resonator with a load capacitance of  $C_L = 6$  pF, and  $C_{stray} = 2$  pF, then  $C_{L1} = C_{L2} = 8$  pF.

**Table 22. LSE oscillator characteristics ( $f_{LSE} = 32.768$  kHz)<sup>(1)</sup>**

Symbol	Parameter	Conditions	Min	Typ	Max	Unit
$R_F$	Feedback resistor			5		M $\Omega$
$C_{L1}$ $C_{L2}$ <sup>(2)</sup>	Recommended load capacitance versus equivalent serial resistance of the crystal ( $R_S$ ) <sup>(3)</sup>	$R_S = 30$ K $\Omega$			15	pF
$I_2$	LSE driving current	$V_{DD} = 3.3$ V $V_{IN} = V_{SS}$			1.4	$\mu$ A
$g_m$	Oscillator transconductance		5			$\mu$ A/V
$t_{SU(LSE)}$ <sup>(4)</sup>	Startup time	$V_{DD}$ is stabilized		3		s

1. Based on characterization, not tested in production.
2. Refer to the note and caution paragraphs above the table.
3. The oscillator selection can be optimized in terms of supply current using an high quality resonator with small  $R_S$  value for example MSIV-TIN32.768 kHz. Refer to crystal manufacturer for more details
4.  $t_{SU(LSE)}$  is the startup time measured from the moment it is enabled (by software) to a stabilized 32.768 kHz oscillation is reached. This value is measured for a standard crystal resonator and it can vary significantly with the crystal manufacturer

**Figure 20. Typical application with a 32.768 kHz crystal**

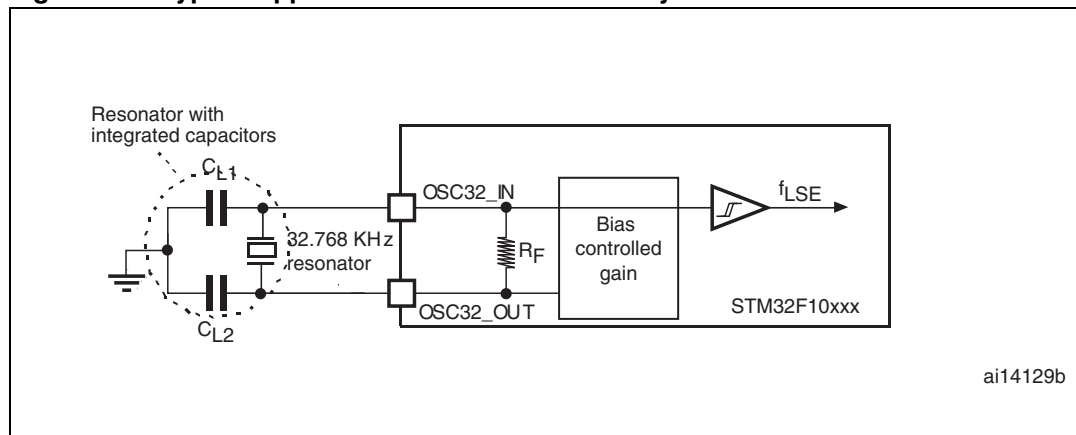

ai14129b

### 5.3.7 Internal clock source characteristics

The parameters given in [Table 23](#) are derived from tests performed under the ambient temperature and  $V_{DD}$  supply voltage conditions summarized in [Table 8](#).

#### High-speed internal (HSI) RC oscillator

**Table 23. HSI oscillator characteristics<sup>(1)(2)</sup>**

Symbol	Parameter	Conditions	Min	Typ	Max	Unit
$f_{HSI}$	Frequency			8		MHz
$ACC_{HSI}$	Accuracy of HSI oscillator	$T_A = -40$ to $85$ °C		$\pm 1$	$\pm 3$	%
		$T_A = -10$ to $85$ °C		$\pm 1$	$\pm 2.5$	%
		$T_A = 0$ to $70$ °C		$\pm 1$	$\pm 2.2$	%
		$T_A = 25$ °C		$\pm 1$	$\pm 2$	%
$t_{su(HSI)}$	HSI oscillator startup time		1		2	$\mu s$
$I_{DD(HSI)}$	HSI oscillator power consumption			80	100	$\mu A$

1. Guaranteed by design, not tested in production.
2.  $V_{DD} = 3.3$  V,  $T_A = -40$  to  $85$  °C unless otherwise specified.

#### Low-speed internal (LSI) RC oscillator

**Table 24. LSI oscillator characteristics<sup>(1)</sup>**

Symbol	Parameter	Min	Typ	Max	Unit
$f_{LSI}^{(2)}$	Frequency	30	40	60	kHz
$t_{su(LSI)}^{(3)}$	LSI oscillator startup time			85	$\mu s$
$I_{DD(LSI)}^{(3)}$	LSI oscillator power consumption		0.65	1.2	$\mu A$

1.  $V_{DD} = 3$  V,  $T_A = -40$  to  $85$  °C unless otherwise specified.
2. Based on characterization, not tested in production.
3. Guaranteed by design, not tested in production.

#### Wakeup time from low-power mode

The wakeup times given in [Table 25](#) is measured on a wakeup phase with a 8-MHz HSI RC oscillator. The clock source used to wake up the device depends from the current operating mode:

- Stop or Standby mode: the clock source is the RC oscillator
- Sleep mode: the clock source is the clock that was set before entering Sleep mode.

All timings are derived from tests performed under the ambient temperature and  $V_{DD}$  supply voltage conditions summarized in [Table 8](#).

**Table 25. Low-power mode wakeup timings**

Symbol	Parameter	Conditions	Typ	Unit
$t_{WUSLEEP}^{(1)}$	Wakeup from Sleep mode	Wakeup on HSI RC clock	1.8	$\mu\text{s}$
$t_{WUSTOP}^{(1)}$	Wakeup from Stop mode (regulator in run mode)	HSI RC wakeup time = 2 $\mu\text{s}$	3.6	$\mu\text{s}$
	Wakeup from Stop mode (regulator in low-power mode)	HSI RC wakeup time = 2 $\mu\text{s}$ , Regulator wakeup from LP mode time = 5 $\mu\text{s}$	5.4	
$t_{WUSTDBY}^{(1)}$	Wakeup from Standby mode	HSI RC wakeup time = 2 $\mu\text{s}$ , Regulator wakeup from power down time = 38 $\mu\text{s}$	50	$\mu\text{s}$

1. The wakeup times are measured from the wakeup event to the point at which the user application code reads the first instruction.

### 5.3.8 PLL characteristics

The parameters given in [Table 26](#) are derived from tests performed under the ambient temperature and  $V_{DD}$  supply voltage conditions summarized in [Table 8](#).

**Table 26. PLL characteristics**

Symbol	Parameter	Test conditions	Value			Unit
			Min <sup>(1)</sup>	Typ	Max <sup>(1)</sup>	
$f_{PLL\_IN}$	PLL input clock <sup>(2)</sup>		1	8.0	25	MHz
	PLL input clock duty cycle		40		60	%
$f_{PLL\_OUT}$	PLL multiplier output clock		16		36	MHz
$t_{LOCK}$	PLL lock time				200	$\mu\text{s}$

1. Based on device characterization, not tested in production.
2. Take care of using the appropriate multiplier factors so as to have PLL input clock values compatible with the range defined by  $f_{PLL\_OUT}$ .

### 5.3.9 Memory characteristics

#### Flash memory

The characteristics are given at  $T_A = -40$  to  $85$  °C unless otherwise specified.

**Table 27. Flash memory characteristics**

Symbol	Parameter	Conditions	Min <sup>(1)</sup>	Typ	Max <sup>(1)</sup>	Unit
$t_{prog}$	16-bit programming time	$T_A = -40$ to $+85$ °C	40	52.5	70	μs
$t_{ERASE}$	Page (1 KB) erase time	$T_A = -40$ to $+85$ °C	20		40	ms
$t_{ME}$	Mass erase time	$T_A = -40$ to $+85$ °C	20		40	ms
$I_{DD}$	Supply current	Read mode $f_{HCLK} = 36$ MHz with 2 wait states, $V_{DD} = 3.3$ V			20	mA
		Write / Erase modes $f_{HCLK} = 36$ MHz, $V_{DD} = 3.3$ V			5	mA
		Power-down mode / Halt, $V_{DD} = 3.0$ to $3.6$ V			50	μA
$V_{prog}$	Programming voltage		2		3.6	V

1. Guaranteed by design, not tested in production.

**Table 28. Flash memory endurance and data retention**

Symbol	Parameter	Conditions	Value			Unit
			Min <sup>(1)</sup>	Typ	Max	
$N_{END}$	Endurance	$T_A = -40$ °C to $85$ °C	10			kcycles
$t_{RET}$	Data retention	$T_A = 85$ °C, 1 kcycle <sup>(2)</sup>	30			Years
		$T_A = 55$ °C, 10 kcycle <sup>(2)</sup>	20			

1. Based on characterization not tested in production.

2. Cycling performed over the whole temperature range.

### 5.3.10 EMC characteristics

Susceptibility tests are performed on a sample basis during device characterization.

#### Functional EMS (Electromagnetic susceptibility)

While a simple application is executed on the device (toggling 2 LEDs through I/O ports), the device is stressed by two electromagnetic events until a failure occurs. The failure is indicated by the LEDs:

- **Electrostatic discharge (ESD)** (positive and negative) is applied to all device pins until a functional disturbance occurs. This test is compliant with the IEC 1000-4-2 standard.
- **FTB: A Burst of Fast Transient voltage** (positive and negative) is applied to  $V_{DD}$  and  $V_{SS}$  through a 100 pF capacitor, until a functional disturbance occurs. This test is compliant with the IEC 1000-4-4 standard.

A device reset allows normal operations to be resumed.

The test results are given in [Table 29](#). They are based on the EMS levels and classes defined in application note AN1709.

**Table 29. EMS characteristics**

Symbol	Parameter	Conditions	Level/Class
$V_{FESD}$	Voltage limits to be applied on any I/O pin to induce a functional disturbance	$V_{DD} = 3.3\text{ V}$ , $T_A = +25\text{ °C}$ , $f_{HCLK} = 36\text{ MHz}$ conforms to IEC 1000-4-2	2B
$V_{EFTB}$	Fast transient voltage burst limits to be applied through 100 pF on $V_{DD}$ and $V_{SS}$ pins to induce a functional disturbance	$V_{DD} = 3.3\text{ V}$ , $T_A = +25\text{ °C}$ , $f_{HCLK} = 36\text{ MHz}$ conforms to IEC 1000-4-4	4A

#### Designing hardened software to avoid noise problems

EMC characterization and optimization are performed at component level with a typical application environment and simplified MCU software. It should be noted that good EMC performance is highly dependent on the user application and the software in particular.

Therefore it is recommended that the user applies EMC software optimization and pre qualification tests in relation with the EMC level requested for his application.

#### Software recommendations

The software flowchart must include the management of runaway conditions such as:

- Corrupted program counter
- Unexpected reset
- Critical Data corruption (control registers...)

#### Prequalification trials

Most of the common failures (unexpected reset and program counter corruption) can be reproduced by manually forcing a low state on the NRST pin or the Oscillator pins for 1 second. To complete these trials, ESD stress can be applied directly on the device, over the range of specification values. When unexpected behavior is detected, the software can be hardened to prevent unrecoverable errors occurring (see application note AN1015).

### Electromagnetic Interference (EMI)

The electromagnetic field emitted by the device is monitored while a simple application is executed (toggling 2 LEDs through the I/O ports). This emission test is compliant with SAE J 1752/3 standard which specifies the test board and the pin loading.

**Table 30. EMI characteristics**

Symbol	Parameter	Conditions	Monitored frequency band	Max vs. [f <sub>HSE</sub> /f <sub>HCLK</sub> ]	Unit
				8/36 MHz	
S <sub>EMI</sub>	Peak level	V <sub>DD</sub> = 3.3 V, T <sub>A</sub> = 25 °C, LQFP100 package compliant with SAE J 1752/3	0.1 MHz to 30 MHz	7	dBμV
			30 MHz to 130 MHz	8	
			130 MHz to 1GHz	13	
			SAE EMI Level	3.5	-

### 5.3.11 Absolute maximum ratings (electrical sensitivity)

Based on three different tests (ESD, LU) using specific measurement methods, the device is stressed in order to determine its performance in terms of electrical sensitivity.

#### Electrostatic discharge (ESD)

Electrostatic discharges (a positive then a negative pulse separated by 1 second) are applied to the pins of each sample according to each pin combination. The sample size depends on the number of supply pins in the device (3 parts × (n+1) supply pins). This test conforms to the JESD22-A114/C101 standard.

**Table 31. ESD absolute maximum ratings**

Symbol	Ratings	Conditions	Class	Maximum value <sup>(1)</sup>	Unit
V <sub>ESD(HBM)</sub>	Electrostatic discharge voltage (human body model)	T <sub>A</sub> = +25 °C conforming to JESD22-A114	2	2000	V
V <sub>ESD(CDM)</sub>	Electrostatic discharge voltage (charge device model)	T <sub>A</sub> = +25 °C conforming to JESD22-C101	II	500	

1. Based on characterization results, not tested in production.

#### Static latch-up

Two complementary static tests are required on six parts to assess the latch-up performance:

- A supply overvoltage is applied to each power supply pin
- A current injection is applied to each input, output and configurable I/O pin

These tests are compliant with EIA/JESD 78 IC latch-up standard.

**Table 32. Electrical sensitivities**

Symbol	Parameter	Conditions	Class
LU	Static latch-up class	T <sub>A</sub> = +85 °C conforming to JESD78A	II level A

### 5.3.12 I/O port characteristics

#### General input/output characteristics

Unless otherwise specified, the parameters given in [Table 33](#) are derived from tests performed under the conditions summarized in [Table 8](#). All I/Os are CMOS and TTL compliant.

**Table 33. I/O static characteristics**

Symbol	Parameter	Conditions	Min	Typ	Max	Unit
$V_{IL}$	Input low level voltage	TTL ports	-0.5		0.8	V
$V_{IH}$	Standard IO input high level voltage		2		$V_{DD}+0.5$	
	IO FT <sup>(1)</sup> input high level voltage		2		5.5V	
$V_{IL}$	Input low level voltage	CMOS ports	-0.5		$0.35 V_{DD}$	V
$V_{IH}$	Input high level voltage		$0.65 V_{DD}$		$V_{DD}+0.5$	
$V_{hys}$	Standard IO Schmitt trigger voltage hysteresis <sup>(2)</sup>		200			mV
	IO FT Schmitt trigger voltage hysteresis <sup>(2)</sup>		$5\% V_{DD}$ <sup>(3)</sup>			mV
$I_{lkg}$	Input leakage current <sup>(3)</sup>	$V_{SS} \leq V_{IN} \leq V_{DD}$ Standard I/Os			$\pm 1$	$\mu A$
		$V_{IN} = 5 V$ I/O FT			3	
$R_{PU}$	Weak pull-up equivalent resistor <sup>(4)</sup>	$V_{IN} = V_{SS}$	30	40	50	$k\Omega$
$R_{PD}$	Weak pull-down equivalent resistor <sup>(5)</sup>	$V_{IN} = V_{DD}$	30	40	50	$k\Omega$
$C_{IO}$	I/O pin capacitance			5		pF

1. FT = Five-volt tolerant.
2. Hysteresis voltage between Schmitt trigger switching levels. Based on characterization, not tested in production.
3. With a minimum of 100 mV.
4. Leakage could be higher than max. if negative current is injected on adjacent pins.
5. Pull-up and pull-down resistors are designed with a true resistance in series with a switchable PMOS/NMOS. This PMOS/NMOS contribution to the series resistance is minimum (~10% order).

### Output driving current

The GPIOs (general purpose input/outputs) can sink or source up to +/-8 mA, and sink +20 mA (with a relaxed  $V_{OL}$ ).

In the user application, the number of I/O pins which can drive current must be limited to respect the absolute maximum rating specified in [Section 5.2](#):

- The sum of the currents sourced by all the I/Os on  $V_{DD}$ , plus the maximum Run consumption of the MCU sourced on  $V_{DD}$ , cannot exceed the absolute maximum rating  $I_{VDD}$  (see [Table 6](#)).
- The sum of the currents sunk by all the I/Os on  $V_{SS}$  plus the maximum Run consumption of the MCU sunk on  $V_{SS}$  cannot exceed the absolute maximum rating  $I_{VSS}$  (see [Table 6](#)).

### Output voltage levels

Unless otherwise specified, the parameters given in [Table 34](#) are derived from tests performed under the ambient temperature and  $V_{DD}$  supply voltage conditions summarized in [Table 8](#). All I/Os are CMOS and TTL compliant.

**Table 34. Output voltage characteristics**

Symbol	Parameter	Conditions	Min	Max	Unit
$V_{OL}^{(1)}$	Output Low level voltage for an I/O pin when 8 pins are sunk at the same time	TTL port, $I_{IO} = +8 \text{ mA}$ , $2.7 \text{ V} < V_{DD} < 3.6 \text{ V}$		0.4	V
$V_{OH}^{(2)}$	Output High level voltage for an I/O pin when 8 pins are sourced at the same time		$V_{DD}-0.4$		
$V_{OL}^{(1)}$	Output low level voltage for an I/O pin when 8 pins are sunk at the same time	CMOS port $I_{IO} = +8 \text{ mA}$ $2.7 \text{ V} < V_{DD} < 3.6 \text{ V}$		0.4	V
$V_{OH}^{(2)}$	Output high level voltage for an I/O pin when 8 pins are sourced at the same time		2.4		
$V_{OL}^{(1)}$	Output low level voltage for an I/O pin when 8 pins are sunk at the same time	$I_{IO} = +20 \text{ mA}^{(3)}$ $2.7 \text{ V} < V_{DD} < 3.6 \text{ V}$		1.3	V
$V_{OH}^{(2)}$	Output high level voltage for an I/O pin when 8 pins are sourced at the same time		$V_{DD}-1.3$		
$V_{OL}^{(1)}$	Output low level voltage for an I/O pin when 8 pins are sunk at the same time	$I_{IO} = +6 \text{ mA}^{(3)}$ $2 \text{ V} < V_{DD} < 2.7 \text{ V}$		0.4	V
$V_{OH}^{(2)}$	Output high level voltage for an I/O pin when 8 pins are sourced at the same time		$V_{DD}-0.4$		

1. The  $I_{IO}$  current sunk by the device must always respect the absolute maximum rating specified in [Table 6](#) and the sum of  $I_{IO}$  (I/O ports and control pins) must not exceed  $I_{VSS}$ .
2. The  $I_{IO}$  current sourced by the device must always respect the absolute maximum rating specified in [Table 6](#) and the sum of  $I_{IO}$  (I/O ports and control pins) must not exceed  $I_{VDD}$ .
3. Based on characterization data, not tested in production.

### Input/output AC characteristics

The definition and values of input/output AC characteristics are given in [Figure 21](#) and [Table 35](#), respectively.

Unless otherwise specified, the parameters given in [Table 35](#) are derived from tests performed under the ambient temperature and  $V_{DD}$  supply voltage conditions summarized in [Table 8](#).

**Table 35. I/O AC characteristics<sup>(1)</sup>**

MODEx [1:0] bit value <sup>(1)</sup>	Symbol	Parameter	Conditions	Max	Unit
10	$f_{\max(\text{IO})\text{out}}$	Maximum frequency <sup>(2)</sup>	$C_L = 50 \text{ pF}$ , $V_{DD} = 2 \text{ V to } 3.6 \text{ V}$	2	MHz
	$t_{f(\text{IO})\text{out}}$	Output high to low level fall time	$C_L = 50 \text{ pF}$ , $V_{DD} = 2 \text{ V to } 3.6 \text{ V}$	125 <sup>(3)</sup>	ns
	$t_{r(\text{IO})\text{out}}$	Output low to high level rise time		125 <sup>(3)</sup>	
01	$f_{\max(\text{IO})\text{out}}$	Maximum frequency <sup>(2)</sup>	$C_L = 50 \text{ pF}$ , $V_{DD} = 2 \text{ V to } 3.6 \text{ V}$	10	MHz
	$t_{f(\text{IO})\text{out}}$	Output high to low level fall time	$C_L = 50 \text{ pF}$ , $V_{DD} = 2 \text{ V to } 3.6 \text{ V}$	25 <sup>(3)</sup>	ns
	$t_{r(\text{IO})\text{out}}$	Output low to high level rise time		25 <sup>(3)</sup>	
11	$F_{\max(\text{IO})\text{out}}$	Maximum Frequency <sup>(2)</sup>	$C_L = 30 \text{ pF}$ , $V_{DD} = 2.7 \text{ V to } 3.6 \text{ V}$	50	MHz
			$C_L = 50 \text{ pF}$ , $V_{DD} = 2.7 \text{ V to } 3.6 \text{ V}$	30	MHz
			$C_L = 50 \text{ pF}$ , $V_{DD} = 2 \text{ V to } 2.7 \text{ V}$	20	MHz
	$t_{f(\text{IO})\text{out}}$	Output high to low level fall time	$C_L = 30 \text{ pF}$ , $V_{DD} = 2.7 \text{ V to } 3.6 \text{ V}$	5 <sup>(3)</sup>	ns
			$C_L = 50 \text{ pF}$ , $V_{DD} = 2.7 \text{ V to } 3.6 \text{ V}$	8 <sup>(3)</sup>	
			$C_L = 50 \text{ pF}$ , $V_{DD} = 2 \text{ V to } 2.7 \text{ V}$	12 <sup>(3)</sup>	
	$t_{r(\text{IO})\text{out}}$	Output low to high level rise time	$C_L = 30 \text{ pF}$ , $V_{DD} = 2.7 \text{ V to } 3.6 \text{ V}$	5 <sup>(3)</sup>	
			$C_L = 50 \text{ pF}$ , $V_{DD} = 2.7 \text{ V to } 3.6 \text{ V}$	8 <sup>(3)</sup>	
			$C_L = 50 \text{ pF}$ , $V_{DD} = 2 \text{ V to } 2.7 \text{ V}$	12 <sup>(3)</sup>	
-	$t_{\text{EXTI}pw}$	Pulse width of external signals detected by the EXTI controller		10	ns

1. The I/O speed is configured using the MODEx[1:0] bits. Refer to the STM32F10xxx reference manual for a description of GPIO Port configuration register.
2. The maximum frequency is defined in [Figure 21](#).
3. Guaranteed by design, not tested in production.

Figure 21. I/O AC characteristics definition

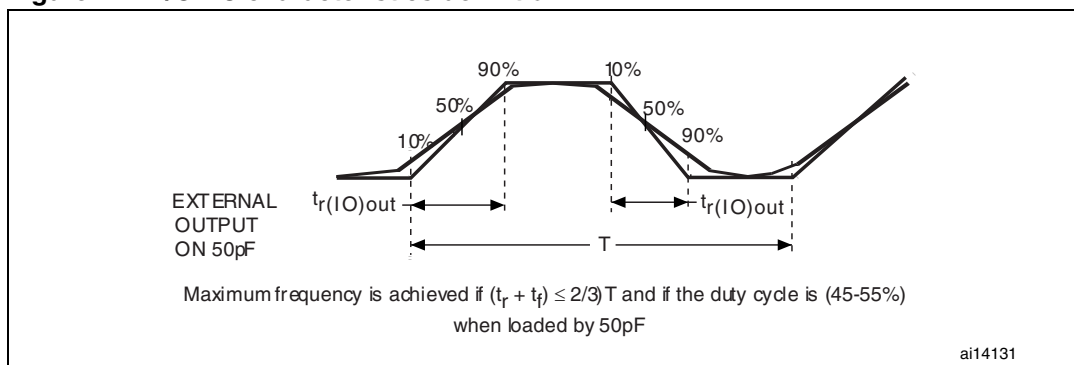

### 5.3.13 NRST pin characteristics

The NRST pin input driver uses CMOS technology. It is connected to a permanent pull-up resistor,  $R_{PU}$  (see [Table 33](#)).

Unless otherwise specified, the parameters given in [Table 36](#) are derived from tests performed under the ambient temperature and  $V_{DD}$  supply voltage conditions summarized in [Table 8](#).

Table 36. NRST pin characteristics

Symbol	Parameter	Conditions	Min	Typ	Max	Unit
$V_{IL(NRST)}^{(1)}$	NRST Input low level voltage		-0.5		0.8	V
$V_{IH(NRST)}^{(1)}$	NRST Input high level voltage		2		$V_{DD}+0.5$	
$V_{hys(NRST)}$	NRST Schmitt trigger voltage hysteresis			200		mV
$R_{PU}$	Weak pull-up equivalent resistor <sup>(2)</sup>	$V_{IN} = V_{SS}$	30	40	50	k $\Omega$
$V_{F(NRST)}^{(1)}$	NRST Input filtered pulse				100	ns
$V_{NF(NRST)}^{(1)}$	NRST Input not filtered pulse		300			ns

1. Guaranteed by design, not tested in production.
2. The pull-up is designed with a true resistance in series with a switchable PMOS. This PMOS contribution to the series resistance must be minimum (~10% order).

Figure 22. Recommended NRST pin protection

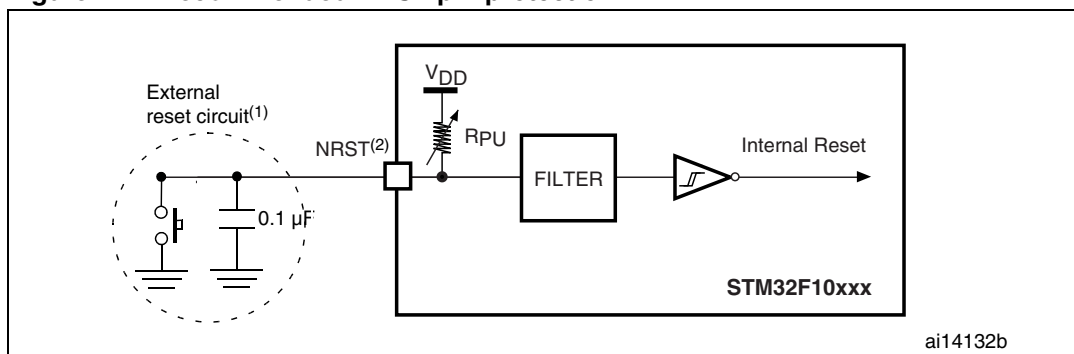

1. The reset network protects the device against parasitic resets.
2. The user must ensure that the level on the NRST pin can go below the  $V_{IL(NRST)}$  max level specified in [Table 36](#). Otherwise the reset will not be taken into account by the device.

### 5.3.14 TIM timer characteristics

The parameters given in [Table 37](#) are guaranteed by design.

Refer to [Section 5.3.12: I/O port characteristics](#) for details on the input/output alternate function characteristics (output compare, input capture, external clock, PWM output).

**Table 37. TIMx<sup>(1)</sup> characteristics**

Symbol	Parameter	Conditions	Min	Max	Unit
$t_{res(TIM)}$	Timer resolution time		1		$t_{TIMxCLK}$
		$f_{TIMxCLK} = 36\text{ MHz}$	27.8		ns
$f_{EXT}$	Timer external clock frequency on CH1 to CH4		0	$f_{TIMxCLK}/2$	MHz
		$f_{TIMxCLK} = 36\text{ MHz}$	0	18	MHz
$Res_{TIM}$	Timer resolution			16	bit
$t_{COUNTER}$	16-bit counter clock period when internal clock is selected		1	65536	$t_{TIMxCLK}$
		$f_{TIMxCLK} = 36\text{ MHz}$	0.0278	1820	$\mu\text{s}$
$t_{MAX\_COUNT}$	Maximum possible count			$65536 \times 65536$	$t_{TIMxCLK}$
		$f_{TIMxCLK} = 36\text{ MHz}$		119.2	s

1. TIMx is used as a general term to refer to the TIM1, TIM2, TIM3 and TIM4 timers.

### 5.3.15 Communications interfaces

#### I<sup>2</sup>C interface characteristics

Unless otherwise specified, the parameters given in [Table 38](#) are derived from tests performed under the ambient temperature,  $f_{PCLK1}$  frequency and  $V_{DD}$  supply voltage conditions summarized in [Table 8](#).

The STM32F101xx Medium-density access line I<sup>2</sup>C interface meets the requirements of the standard I<sup>2</sup>C communication protocol with the following restrictions: the I/O pins SDA and SCL are mapped to are not “true” open-drain. When configured as open-drain, the PMOS connected between the I/O pin and  $V_{DD}$  is disabled, but is still present.

The I<sup>2</sup>C characteristics are described in [Table 38](#). Refer also to [Section 5.3.12: I/O port characteristics](#) for more details on the input/output alternate function characteristics (SDA and SCL).

**Table 38. I<sup>2</sup>C characteristics**

Symbol	Parameter	Standard mode I <sup>2</sup> C <sup>(1)</sup>		Fast mode I <sup>2</sup> C <sup>(1)(2)</sup>		Unit
		Min	Max	Min	Max	
t <sub>w(SCLL)</sub>	SCL clock low time	4.7		1.3		μs
t <sub>w(SCLH)</sub>	SCL clock high time	4.0		0.6		
t <sub>su(SDA)</sub>	SDA setup time	250		100		ns
t <sub>h(SDA)</sub>	SDA data hold time	0 <sup>(3)</sup>		0 <sup>(4)</sup>	900 <sup>(3)</sup>	
t <sub>r(SDA)</sub> t <sub>r(SCL)</sub>	SDA and SCL rise time		1000	20+0.1C <sub>b</sub>	300	
t <sub>f(SDA)</sub> t <sub>f(SCL)</sub>	SDA and SCL fall time		300		300	
t <sub>h(STA)</sub>	Start condition hold time	4.0		0.6		μs
t <sub>su(STA)</sub>	Repeated Start condition setup time	4.7		0.6		
t <sub>su(STO)</sub>	Stop condition setup time	4.0		0.6		μs
t <sub>w(STO:STA)</sub>	Stop to Start condition time (bus free)	4.7		1.3		μs
C <sub>b</sub>	Capacitive load for each bus line		400		400	pF

1. Guaranteed by design, not tested in production.
2. f<sub>PCLK1</sub> must be higher than 2 MHz to achieve the maximum standard mode I<sup>2</sup>C frequency. It must be higher than 4 MHz to achieve the maximum fast mode I<sup>2</sup>C frequency.
3. The maximum hold time of the Start condition has only to be met if the interface does not stretch the low period of SCL signal.
4. The device must internally provide a hold time of at least 300 ns for the SDA signal in order to bridge the undefined region of the falling edge of SCL.

Figure 23. I<sup>2</sup>C bus AC waveforms and measurement circuit<sup>(1)</sup>

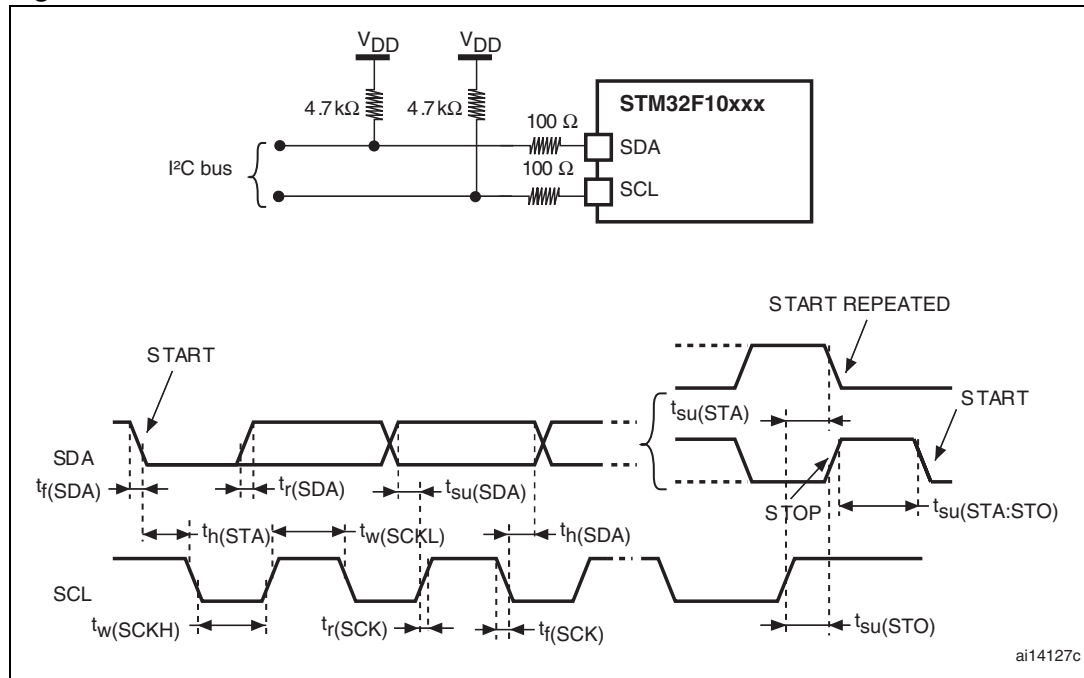

1. Measurement points are done at CMOS levels:  $0.3V_{DD}$  and  $0.7V_{DD}$ .

Table 39. SCL frequency ( $f_{PCLK1} = 36 \text{ MHz}$ ,  $V_{DD} = 3.3 \text{ V}$ )<sup>(1)(2)</sup>

$f_{SCL}$ (kHz)	I2C_CCR value
	$R_p = 4.7 \text{ k}\Omega$
400	0x801E
300	0x8028
200	0x803C
100	0x00B4
50	0x0168
20	0x0384

- $R_p$  = External pull-up resistance,  $f_{SCL}$  = I<sup>2</sup>C speed,
- For speeds around 200 kHz, the tolerance on the achieved speed is of  $\pm 5\%$ . For other speed ranges, the tolerance on the achieved speed  $\pm 2\%$ . These variations depend on the accuracy of the external components used to design the application.

### SPI interface characteristics

Unless otherwise specified, the parameters given in [Table 40](#) are derived from tests performed under the ambient temperature,  $f_{PCLKx}$  frequency and  $V_{DD}$  supply voltage conditions summarized in [Table 8](#).

Refer to [Section 5.3.12: I/O port characteristics](#) for more details on the input/output alternate function characteristics (NSS, SCK, MOSI, MISO).

**Table 40. SPI characteristics<sup>(1)</sup>**

Symbol	Parameter	Conditions	Min	Max	Unit
$f_{SCK}$ $1/t_{c(SCK)}$	SPI clock frequency	Master mode	0	18	MHz
		Slave mode	0	18	
$t_{r(SCK)}$ $t_{f(SCK)}$	SPI clock rise and fall time	Capacitive load: C = 30 pF		8	ns
$t_{su(NSS)}^{(2)}$	NSS setup time	Slave mode	$4 t_{PCLK}$		
$t_{h(NSS)}^{(2)}$	NSS hold time	Slave mode	73		
$t_{w(SCKH)}^{(2)}$ $t_{w(SCKL)}^{(2)}$	SCK high and low time	Master mode, $f_{PCLK} = 36$ MHz, presc = 4	50	60	
$t_{su(MI)}^{(2)}$	Data input setup time Master mode	SPI1	1		
		SPI2	5		
$t_{su(SI)}^{(2)}$	Data input setup time Slave mode		1		
$t_{h(MI)}^{(2)}$	Data input hold time Master mode	SPI1	1		
		SPI2	5		
$t_{h(SI)}^{(2)}$	Data input hold time Slave mode		3		
$t_{a(SO)}^{(2)(3)}$	Data output access time	Slave mode, $f_{PCLK} = 36$ MHz, presc = 4	0	55	
		Slave mode, $f_{PCLK} = 24$ MHz	0	$4 t_{PCLK}$	
$t_{dis(SO)}^{(2)(4)}$	Data output disable time	Slave mode	10		
$t_{v(SO)}^{(2)(1)}$	Data output valid time	Slave mode (after enable edge)		25	
$t_{v(MO)}^{(2)(1)}$	Data output valid time	Master mode (after enable edge)		3	
$t_{h(SO)}^{(2)}$	Data output hold time	Slave mode (after enable edge)	25		
$t_{h(MO)}^{(2)}$		Master mode (after enable edge)	4		

1. Remapped SPI1 characteristics to be determined.
2. Based on characterization, not tested in production.
3. Min time is for the minimum time to drive the output and the max time is for the maximum time to validate the data.
4. Min time is for the minimum time to invalidate the output and the max time is for the maximum time to put the data in Hi-Z

Figure 24. SPI timing diagram - slave mode and CPHA = 0

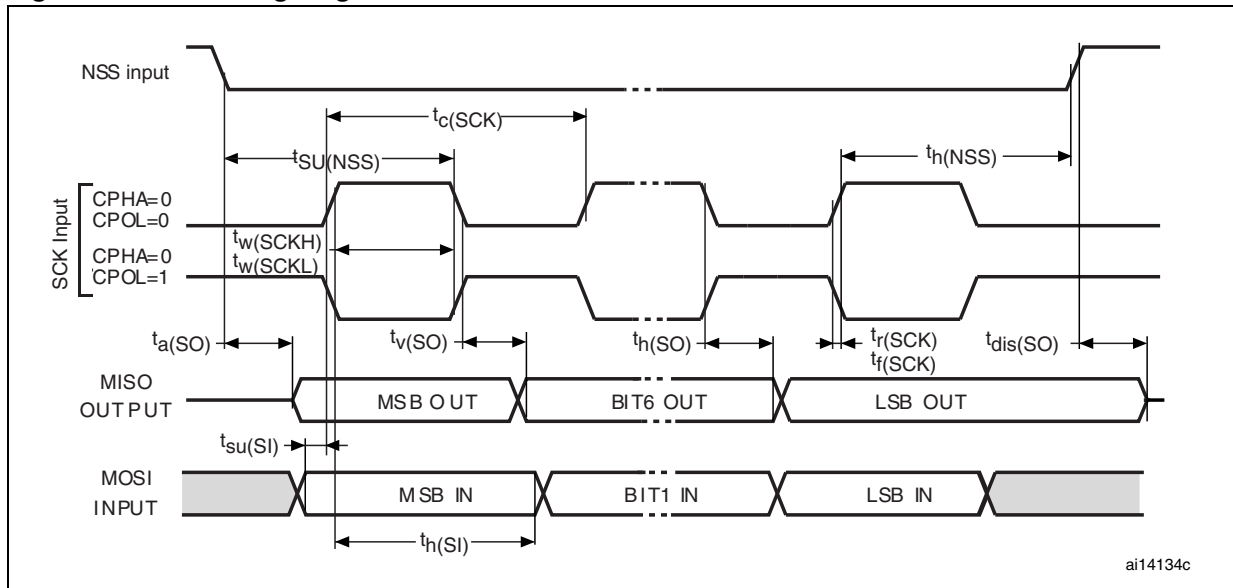
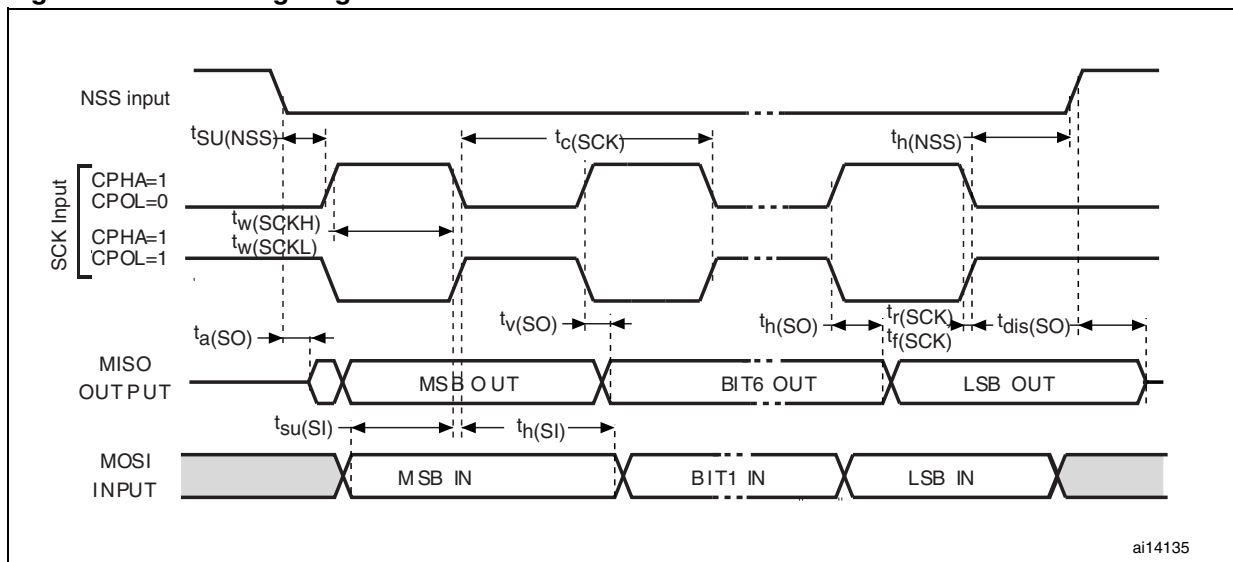
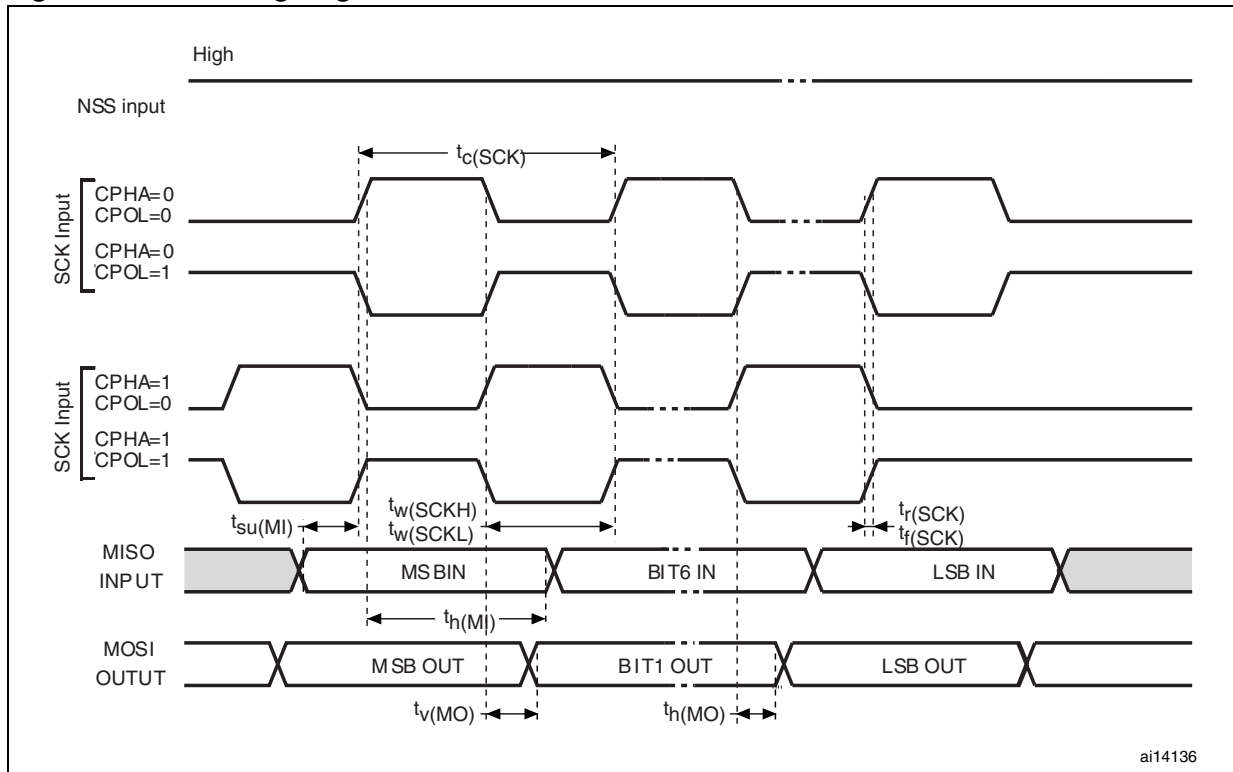

Figure 25. SPI timing diagram - slave mode and CPHA = 1<sup>(1)</sup>



1. Measurement points are done at CMOS levels:  $0.3V_{DD}$  and  $0.7V_{DD}$ .

Figure 26. SPI timing diagram - master mode<sup>(1)</sup>



1. Measurement points are done at CMOS levels:  $0.3V_{DD}$  and  $0.7V_{DD}$ .

### 5.3.16 12-bit ADC characteristics

Unless otherwise specified, the parameters given in [Table 41](#) are derived from tests performed under the ambient temperature,  $f_{PCLK2}$  frequency and  $V_{DDA}$  supply voltage conditions summarized in [Table 8](#).

*Note:* It is recommended to perform a calibration after each power-up.

**Table 41. ADC characteristics**

Symbol	Parameter	Conditions	Min	Typ	Max	Unit
$V_{DDA}$	Power supply		2.4		3.6	V
$V_{REF+}$	Positive reference voltage		2.4		$V_{DDA}$	V
$I_{VREF}$	Current on the $V_{REF}$ input pin			160 <sup>(1)</sup>	220 <sup>(1)</sup>	$\mu$ A
$f_{ADC}$	ADC clock frequency		0.6		14	MHz
$f_S^{(2)}$	Sampling rate		0.05		1	MHz
$f_{TRIG}^{(2)}$	External trigger frequency	$f_{ADC} = 14$ MHz			823	kHz
					17	$1/f_{ADC}$
$V_{AIN}$	Conversion voltage range <sup>(3)</sup>		0 ( $V_{SSA}$ or $V_{REF-}$ tied to ground)		$V_{REF+}$	V
$R_{AIN}^{(2)}$	External input impedance		See <a href="#">Equation 1</a> and <a href="#">Table 42</a>			k $\Omega$
$R_{ADC}^{(2)}$	Sampling switch resistance				1	k $\Omega$
$C_{ADC}^{(2)}$	Internal sample and hold capacitor				12	pF
$t_{CAL}^{(2)}$	Calibration time	$f_{ADC} = 14$ MHz	5.9			$\mu$ s
			83			$1/f_{ADC}$
$t_{iat}^{(2)}$	Injection trigger conversion latency	$f_{ADC} = 14$ MHz			0.214	$\mu$ s
					3 <sup>(4)</sup>	$1/f_{ADC}$
$t_{latr}^{(2)}$	Regular trigger conversion latency	$f_{ADC} = 14$ MHz			0.143	$\mu$ s
					2 <sup>(4)</sup>	$1/f_{ADC}$
$t_S^{(2)}$	Sampling time	$f_{ADC} = 14$ MHz	0.107		17.1	$\mu$ s
			1.5		239.5	$1/f_{ADC}$
$t_{STAB}^{(2)}$	Power-up time		0	0	1	$\mu$ s
$t_{CONV}^{(2)}$	Total conversion time (including sampling time)	$f_{ADC} = 14$ MHz	1		18	$\mu$ s
			14 to 252 ( $t_S$ for sampling + 12.5 for successive approximation)			$1/f_{ADC}$

1. Based on characterization results, not tested in production.
2. Guaranteed by design, not tested in production.
3.  $V_{REF+}$  can be internally connected to  $V_{DDA}$  and  $V_{REF-}$  can be internally connected to  $V_{SSA}$ , depending on the package. Refer to [Section 3: Pin descriptions](#) for further details.
4. For external triggers, a delay of  $1/f_{PCLK2}$  must be added to the latency specified in [Table 41](#).

**Equation 1: R<sub>AIN</sub> max formula:**

$$R_{AIN} < \frac{T_S}{f_{ADC} \times C_{ADC} \times \ln(2^{N+2})} - R_{ADC}$$

The formula above ([Equation 1](#)) is used to determine the maximum external impedance allowed for an error below 1/4 of LSB. Here N = 12 (from 12-bit resolution).

**Table 42. R<sub>AIN</sub> max for f<sub>ADC</sub> = 14 MHz<sup>(1)</sup>**

T <sub>s</sub> (cycles)	t <sub>s</sub> (μs)	R <sub>AIN</sub> max (kΩ)
1.5	0.11	1.2
7.5	0.54	10
13.5	0.96	19
28.5	2.04	41
41.5	2.96	60
55.5	3.96	80
71.5	5.11	104
239.5	17.1	350

1. Guaranteed by design, not tested in production.

**Table 43. ADC accuracy - limited test conditions<sup>(1) (2)</sup>**

Symbol	Parameter	Test conditions	Typ	Max <sup>(3)</sup>	Unit
ET	Total unadjusted error	f <sub>PCLK2</sub> = 28 MHz, f <sub>ADC</sub> = 14 MHz, R <sub>AIN</sub> < 10 kΩ, V <sub>DDA</sub> = 3 V to 3.6 V T <sub>A</sub> = 25 °C Measurements made after ADC calibration V <sub>REF+</sub> = V <sub>DDA</sub>	±1.3	±2	LSB
EO	Offset error		±1	±1.5	
EG	Gain error		±0.5	±1.5	
ED	Differential linearity error		±0.7	±1	
EL	Integral linearity error		±0.8	±1.5	

- ADC DC accuracy values are measured after internal calibration.
- ADC Accuracy vs. Negative Injection Current: Injecting negative current on any of the standard (non-robust) analog input pins should be avoided as this significantly reduces the accuracy of the conversion being performed on another analog input. It is recommended to add a Schottky diode (pin to ground) to standard analog pins which may potentially inject negative current. Any positive injection current within the limits specified for I<sub>INJ(PIN)</sub> and ΣI<sub>INJ(PIN)</sub> in [Section 5.3.12](#) does not affect the ADC accuracy.
- Based on characterization, not tested in production.

**Table 44. ADC accuracy<sup>(1) (2) (3)</sup>**

Symbol	Parameter	Test conditions	Typ	Max <sup>(4)</sup>	Unit
ET	Total unadjusted error	$f_{PCLK2} = 28 \text{ MHz}$ , $f_{ADC} = 14 \text{ MHz}$ , $R_{AIN} < 10 \text{ k}\Omega$ , $V_{DDA} = 2.4 \text{ V to } 3.6 \text{ V}$ Measurements made after ADC calibration	$\pm 2$	$\pm 5$	LSB
EO	Offset error		$\pm 1.5$	$\pm 2.5$	
EG	Gain error		$\pm 1.5$	$\pm 3$	
ED	Differential linearity error		$\pm 1$	$\pm 2$	
EL	Integral linearity error		$\pm 1.5$	$\pm 3$	

1. ADC DC accuracy values are measured after internal calibration.
2. Better performance could be achieved in restricted  $V_{DD}$ , frequency,  $V_{REF}$  and temperature ranges.
3. ADC Accuracy vs. Negative Injection Current: Injecting negative current on any of the standard (non-robust) analog input pins should be avoided as this significantly reduces the accuracy of the conversion being performed on another analog input. It is recommended to add a Schottky diode (pin to ground) to standard analog pins which may potentially inject negative current. Any positive injection current within the limits specified for  $I_{INJ(PIN)}$  and  $\Sigma I_{INJ(PIN)}$  in [Section 5.3.12](#) does not affect the ADC accuracy.
4. Based on characterization, not tested in production.

**Figure 27. ADC accuracy characteristics**

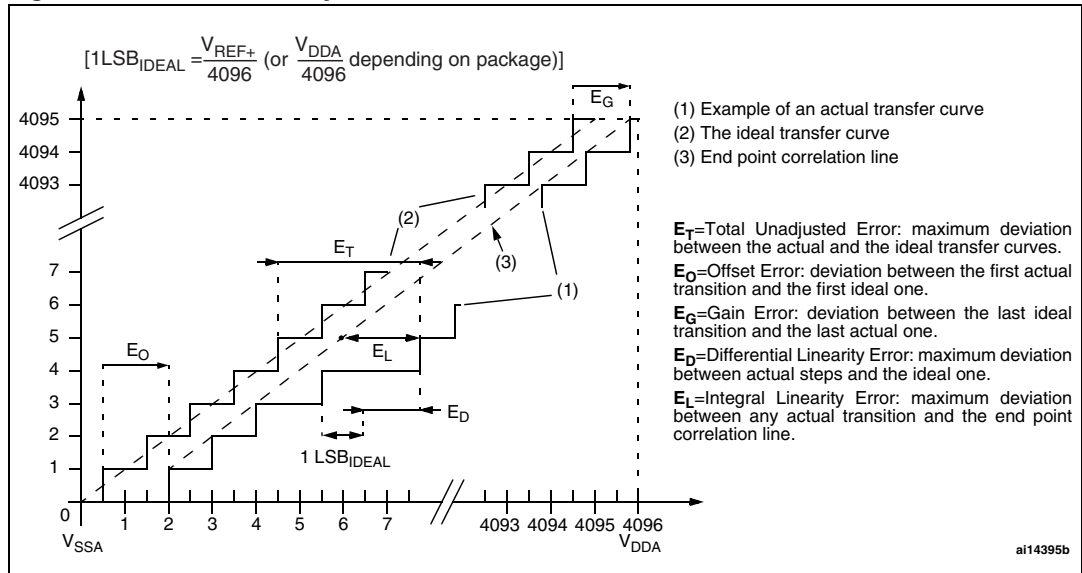
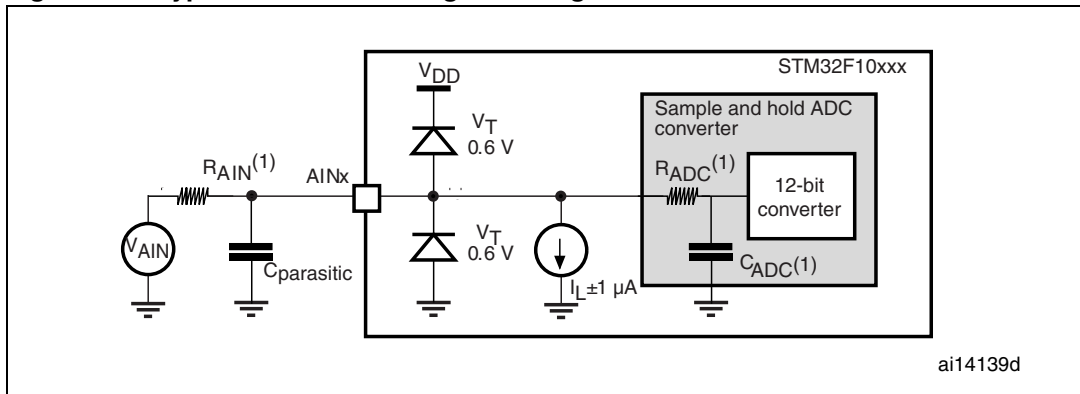

Figure 28. Typical connection diagram using the ADC



1. Refer to [Table 41](#) for the values of  $R_{AIN}$ ,  $R_{ADC}$  and  $C_{ADC}$ .
2.  $C_{parasitic}$  represents the capacitance of the PCB (dependent on soldering and PCB layout quality) plus the pad capacitance (roughly 7 pF). A high  $C_{parasitic}$  value will downgrade conversion accuracy. To remedy this,  $f_{ADC}$  should be reduced.

**General PCB design guidelines**

Power supply decoupling should be performed as shown in [Figure 29](#) or [Figure 30](#), depending on whether  $V_{REF+}$  is connected to  $V_{DDA}$  or not. The 10 nF capacitors should be ceramic (good quality). They should be placed them as close as possible to the chip.

Figure 29. Power supply and reference decoupling ( $V_{REF+}$  not connected to  $V_{DDA}$ )

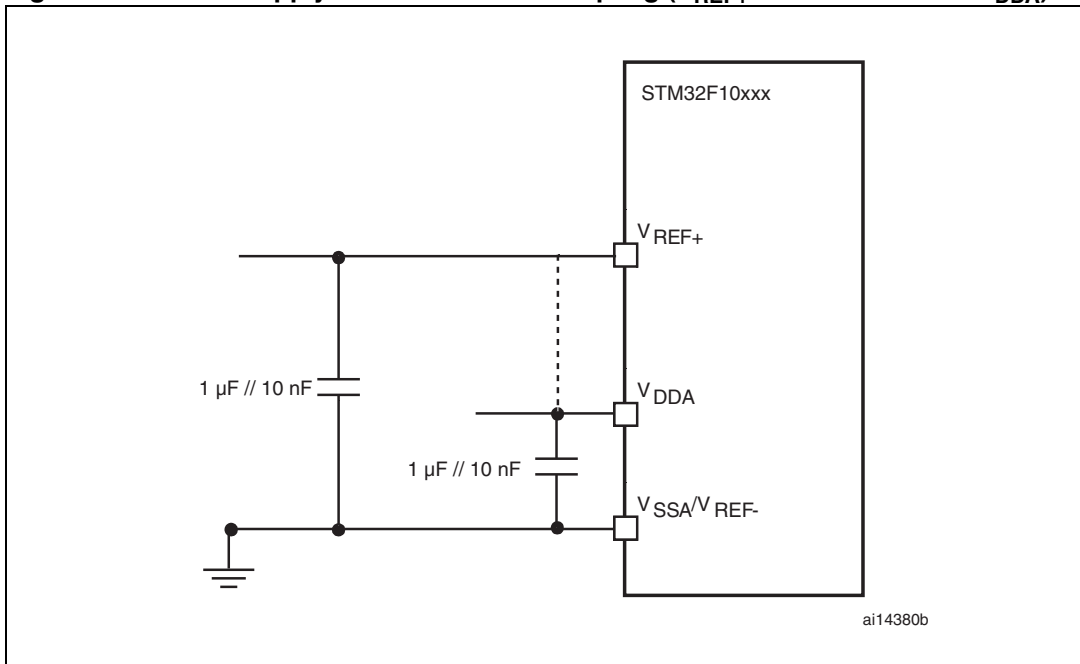

1.  $V_{REF+}$  and  $V_{REF-}$  inputs are available only on 100-pin packages.

Figure 30. Power supply and reference decoupling ( $V_{REF+}$  connected to  $V_{DDA}$ )

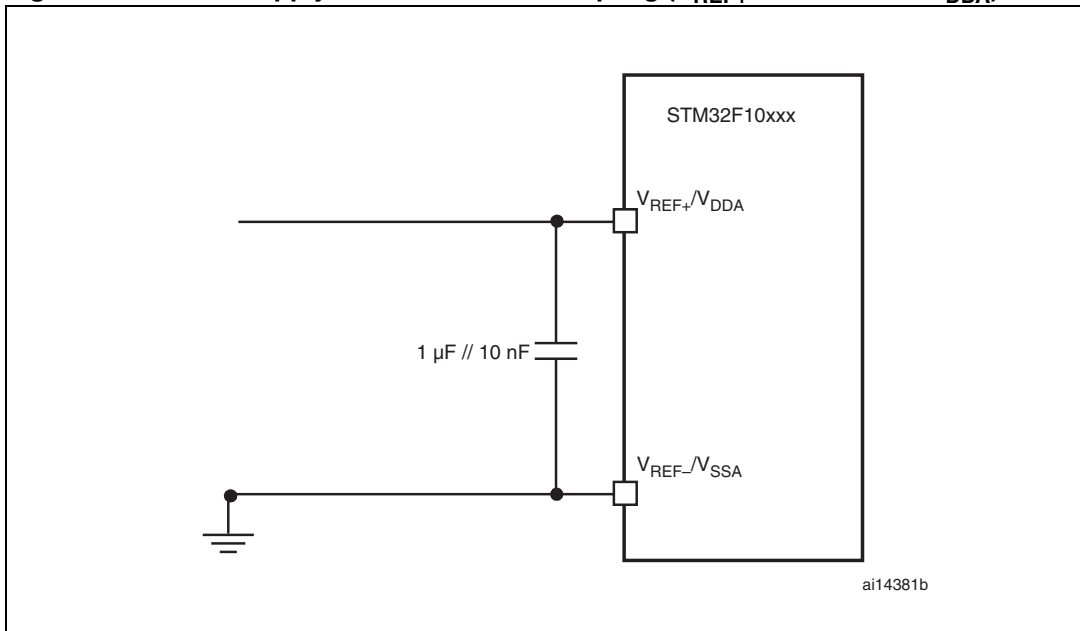

1.  $V_{REF+}$  and  $V_{REF-}$  inputs are available only on 100-pin packages.

### 5.3.17 Temperature sensor characteristics

Table 45. TS characteristics

Symbol	Parameter	Min	Typ	Max	Unit
$T_L^{(1)}$	$V_{SENSE}$ linearity with temperature		$\pm 1$	$\pm 2$	$^{\circ}\text{C}$
Avg_Slope <sup>(1)</sup>	Average slope	4.0	4.3	4.6	mV/ $^{\circ}\text{C}$
$V_{25}^{(1)}$	Voltage at 25 $^{\circ}\text{C}$	1.34	1.43	1.52	V
$t_{START}^{(2)}$	Startup time	4		10	$\mu\text{s}$
$T_{S\_temp}^{(3)(2)}$	ADC sampling time when reading the temperature			17.1	$\mu\text{s}$

1. Guaranteed by characterization, not tested in production.
2. Guaranteed by design, not tested in production.
3. Shortest sampling time can be determined in the application by multiple iterations.

## 6 Package characteristics

### 6.1 Package mechanical data

In order to meet environmental requirements, ST offers the STM32F101xx in ECOPACK® packages. These packages have a Lead-free second-level interconnect. The category of second-level interconnect is marked on the package and on the inner box label, in compliance with JEDEC Standard JESD97.

The maximum ratings related to soldering conditions are also marked on the inner box label.

ECOPACK is an ST trademark. ECOPACK specifications are available at: [www.st.com](http://www.st.com).

Figure 31. VFQFPN36 6 x 6 mm, 0.5 mm pitch, package outline<sup>(1)</sup> Figure 32. Recommended footprint (dimensions in mm)<sup>(1)(2)(3)</sup>

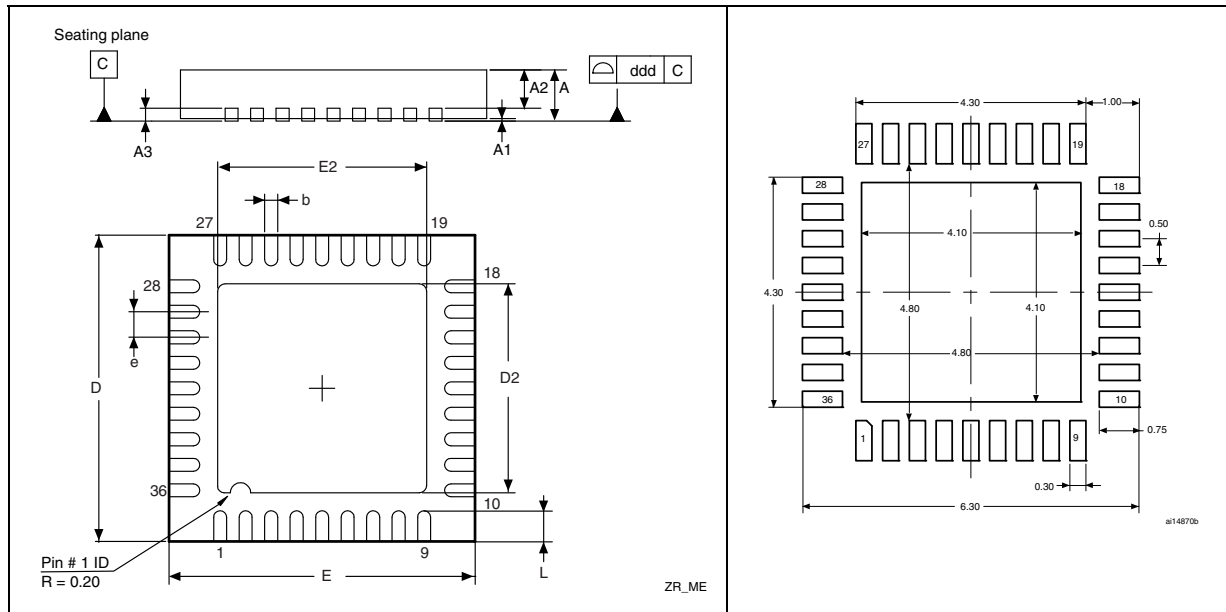

1. Drawing is not to scale.
2. The back-side pad is not internally connected to the V<sub>SS</sub> or V<sub>DD</sub> power pads.
3. There is an exposed die pad on the underside of the VFQFPN package. It should be soldered to the PCB. All leads should also be soldered to the PCB.

Table 46. VFQFPN36 6 x 6 mm, 0.5 mm pitch, package mechanical data

Symbol	millimeters			inches <sup>(1)</sup>		
	Min	Typ	Max	Min	Typ	Max
A	0.800	0.900	1.000	0.0315	0.0354	0.0394
A1		0.020	0.050		0.0008	0.0020
A2		0.650	1.000		0.0256	0.0394
A3		0.250			0.0098	
b	0.180	0.230	0.300	0.0071	0.0091	0.0118
D	5.875	6.000	6.125	0.2313	0.2362	0.2411
D2	1.750	3.700	4.250	0.0689	0.1457	0.1673
E	5.875	6.000	6.125	0.2313	0.2362	0.2411
E2	1.750	3.700	4.250	0.0689	0.1457	0.1673
e	0.450	0.500	0.550	0.0177	0.0197	0.0217
L	0.350	0.550	0.750	0.0138	0.0217	0.0295
ddd		0.080			0.0031	

1. Values in inches are converted from mm and rounded to 4 decimal digits.

Figure 33. LQFP100, 100-pin low-profile quad flat package outline<sup>(1)</sup>

Figure 34. Recommended footprint<sup>(1)(2)</sup>

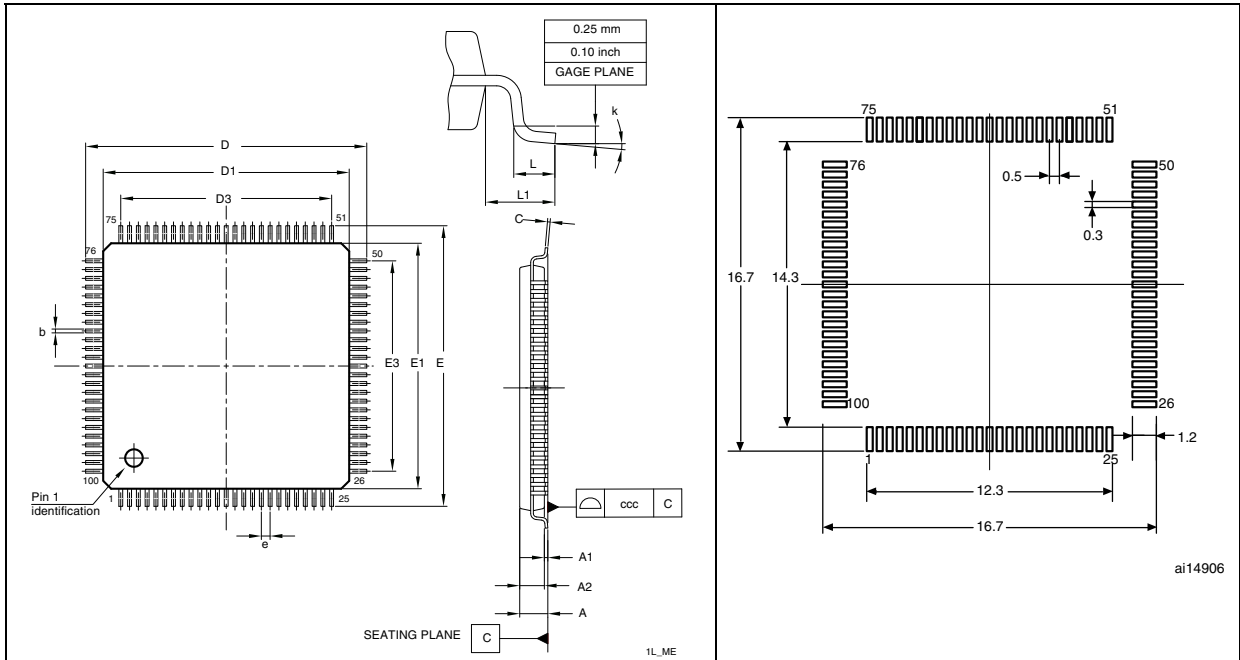

1. Drawing is not to scale.
2. Dimensions are in millimeters.

Table 47. LQFP100 – 100-pin low-profile quad flat package mechanical data

Symbol	millimeters			inches <sup>(1)</sup>		
	Typ	Min	Max	Typ	Min	Max
A			1.60			0.063
A1		0.05	0.15		0.002	0.0059
A2	1.40	1.35	1.45	0.0551	0.0531	0.0571
b	0.22	0.17	0.27	0.0087	0.0067	0.0106
c		0.09	0.2		0.0035	0.0079
D	16.00	15.80	16.2	0.6299	0.622	0.6378
D1	14.00	13.80	14.2	0.5512	0.5433	0.5591
D3	12.00			0.4724		
E	16.00	15.80	16.2	0.6299	0.622	0.6378
E1	14.00	13.80	14.2	0.5512	0.5433	0.5591
E3	12.00			0.4724		
e	0.50			0.0197		
L	0.60	0.45	0.75	0.0236	0.0177	0.0295
L1	1.00			0.0394		
k	3.5°	0°	7°	3.5°	0.0°	7.0°
ccc		0.08			0.0031	

1. Values in inches are converted from mm and rounded to 4 decimal digits.

Figure 35. LQFP64 – 64 pin low-profile quad flat package outline<sup>(1)</sup>

Figure 36. Recommended footprint<sup>(1)(2)</sup>

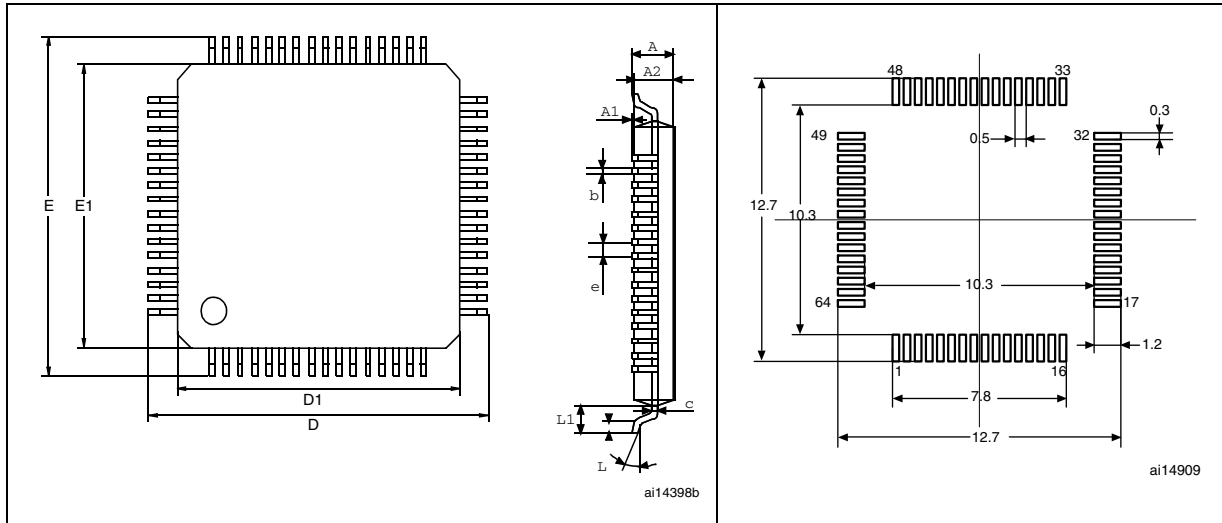

1. Drawing is not to scale.
2. Dimensions are in millimeters.

Table 48. LQFP64 – 64-pin low-profile quad flat package mechanical data

Dim.	mm			inches <sup>(1)</sup>		
	Min	Typ	Max	Min	Typ	Max
A			1.60			0.0630
A1	0.05		0.15	0.0020		0.0059
A2	1.35	1.40	1.45	0.0531	0.0551	0.0571
b	0.17	0.22	0.27	0.0067	0.0087	0.0106
c	0.09		0.20	0.0035		0.0079
D		12.00			0.4724	
D1		10.00			0.3937	
E		12.00			0.4724	
E1		10.00			0.3937	
e		0.50			0.0197	
θ	0°	3.5°	7°	0°	3.5°	7°
L	0.45	0.60	0.75	0.0177	0.0236	0.0295
L1		1.00			0.0394	
<b>Number of pins</b>						
N	64					

1. Values in inches are converted from mm and rounded to 4 decimal digits.

Figure 37. LQFP48 – 48-pin low-profile quad flat package outline<sup>(1)</sup>

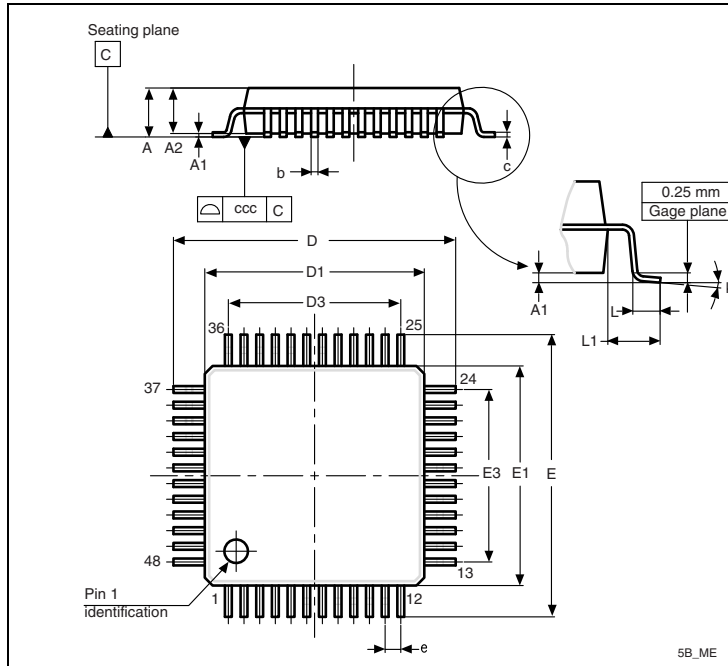
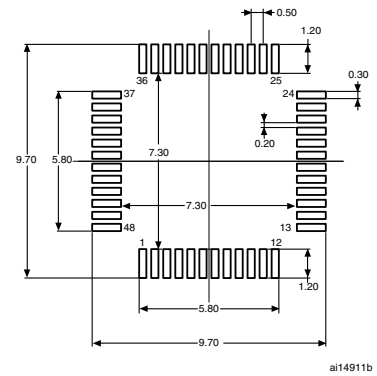

Figure 38. Recommended footprint<sup>(1)(2)</sup>



1. Drawing is not to scale.
2. Dimensions are in millimeters.

Table 49. LQFP48 – 48-pin low-profile quad flat package mechanical data

Symbol	millimeters			inches <sup>(1)</sup>		
	Typ	Min	Max	Typ	Min	Max
A			1.600			0.0630
A1		0.050	0.150		0.0020	0.0059
A2	1.400	1.350	1.450	0.0551	0.0531	0.0571
b	0.220	0.170	0.270	0.0087	0.0067	0.0106
c		0.090	0.200		0.0035	0.0079
D	9.000	8.800	9.200	0.3543	0.3465	0.3622
D1	7.000	6.800	7.200	0.2756	0.2677	0.2835
D3	5.500			0.2165		
E	9.000	8.800	9.200	0.3543	0.3465	0.3622
E1	7.000	6.800	7.200	0.2756	0.2677	0.2835
E3	5.500			0.2165		
e	0.500			0.0197		
L	0.600	0.450	0.750	0.0236	0.0177	0.0295
L1	1.000			0.0394		
k	3.5°	0°	7°	3.5°	0°	7°
ccc		0.080			0.0031	

1. Values in inches are converted from mm and rounded to 4 decimal digits.

## 6.2 Thermal characteristics

The maximum chip junction temperature ( $T_{Jmax}$ ) must never exceed the values given in [Table 8: General operating conditions on page 28](#).

The maximum chip-junction temperature,  $T_J$  max, in degrees Celsius, may be calculated using the following equation:

$$T_J \text{ max} = T_A \text{ max} + (P_D \text{ max} \times \Theta_{JA})$$

Where:

- $T_A$  max is the maximum ambient temperature in °C,
- $\Theta_{JA}$  is the package junction-to-ambient thermal resistance, in °C/W,
- $P_D$  max is the sum of  $P_{INT}$  max and  $P_{I/O}$  max ( $P_D \text{ max} = P_{INT} \text{ max} + P_{I/O} \text{ max}$ ),
- $P_{INT}$  max is the product of  $I_{DD}$  and  $V_{DD}$ , expressed in Watts. This is the maximum chip internal power.

$P_{I/O}$  max represents the maximum power dissipation on output pins where:

$$P_{I/O} \text{ max} = \Sigma (V_{OL} \times I_{OL}) + \Sigma ((V_{DD} - V_{OH}) \times I_{OH}),$$

taking into account the actual  $V_{OL} / I_{OL}$  and  $V_{OH} / I_{OH}$  of the I/Os at low and high level in the application.

**Table 50. Thermal characteristics**

Symbol	Parameter	Value	Unit
$\Theta_{JA}$	Thermal resistance junction-ambient LQFP 100 - 14 x 14 mm / 0.5 mm pitch	46	°C/W
	Thermal resistance junction-ambient LQFP 64 - 10 x 10 mm / 0.5 mm pitch	45	
	Thermal resistance junction-ambient LQFP 48 - 7 x 7 mm / 0.5 mm pitch	55	
	Thermal resistance junction-ambient VFQFPN 36 - 6 x 6 mm / 0.5 mm pitch	18	

### 6.2.1 Reference document

JESD51-2 Integrated Circuits Thermal Test Method Environment Conditions - Natural Convection (Still Air). Available from [www.jedec.org](http://www.jedec.org).

### 6.2.2 Evaluating the maximum junction temperature for an application

When ordering the microcontroller, the temperature range is specified in the ordering information scheme shown in [Table 51: Ordering information scheme](#).

Each temperature range suffix corresponds to a specific guaranteed ambient temperature at maximum dissipation and, to a specific maximum junction temperature. Here, only temperature range 6 is available (−40 to 85 °C).

The following example shows how to calculate the temperature range needed for a given application, making it possible to check whether the required temperature range is compatible with the STM32F101xx junction temperature range.

#### Example: High-performance application

Assuming the following application conditions:

Maximum ambient temperature  $T_{Amax} = 82\text{ °C}$  (measured according to JESD51-2),  
 $I_{DDmax} = 50\text{ mA}$ ,  $V_{DD} = 3.5\text{ V}$ , maximum 20 I/Os used at the same time in output at low level with  $I_{OL} = 8\text{ mA}$ ,  $V_{OL} = 0.4\text{ V}$  and maximum 8 I/Os used at the same time in output mode at low level with  $I_{OL} = 20\text{ mA}$ ,  $V_{OL} = 1.3\text{ V}$

$$P_{INTmax} = 50\text{ mA} \times 3.5\text{ V} = 175\text{ mW}$$

$$P_{IOmax} = 20 \times 8\text{ mA} \times 0.4\text{ V} + 8 \times 20\text{ mA} \times 1.3\text{ V} = 272\text{ mW}$$

This gives:  $P_{INTmax} = 175\text{ mW}$  and  $P_{IOmax} = 272\text{ mW}$

$$P_{Dmax} = 175 + 272 = 447\text{ mW}$$

Thus:  $P_{Dmax} = 464\text{ mW}$

Using the values obtained in [Table 50](#)  $T_{Jmax}$  is calculated as follows:

– For LQFP64, 45 °C/W

$$T_{Jmax} = 82\text{ °C} + (45\text{ °C/W} \times 447\text{ mW}) = 82\text{ °C} + 20.1\text{ °C} = 102.1\text{ °C}$$

This is within the junction temperature range of the STM32F101xx (−40 <  $T_J$  < 105 °C).

**Figure 39. LQFP64  $P_D$  max vs.  $T_A$**

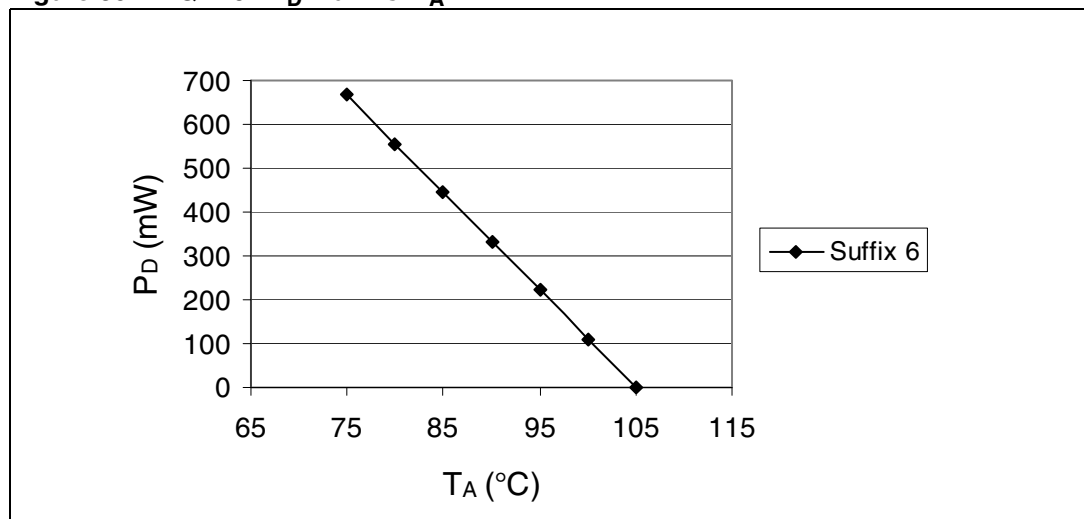

# 7 Ordering information scheme

**Table 51. Ordering information scheme**

<p>Example:</p> <p><b>Device family</b> STM32 = ARM-based 32-bit microcontroller</p> <p><b>Product type</b> F = general-purpose</p> <p><b>Device subfamily</b> 101 = access line</p> <p><b>Pin count</b> T = 36 pins C = 48 pins R = 64 pins V = 100 pins</p> <p><b>Flash memory size</b> 6 = 32 Kbytes of Flash memory 8 = 64 Kbytes of Flash memory B = 128 Kbytes of Flash memory</p> <p><b>Package</b> H = BGA T = LQFP U = VFQFPN</p> <p><b>Temperature range</b> 6 = Industrial temperature range, -40 to 85 °C.</p> <p><b>Options</b> xxx = programmed parts TR = tape and real</p>	<p>STM32 F 101 C 6 T 6 xxx</p>
------------------------------------------------------------------------------------------------------------------------------------------------------------------------------------------------------------------------------------------------------------------------------------------------------------------------------------------------------------------------------------------------------------------------------------------------------------------------------------------------------------------------------------------------------------------------------------------------------------------------------------------------------------	--------------------------------

For a list of available options (speed, package, etc.) or for further information on any aspect of this device, please contact your nearest ST sales office.

## 7.1 Future family enhancements

Further developments of the STM32F101xx access line include devices with a lower Flash memory and SRAM capacity for applications where large memory sizes are not useful.

## 8 Revision history

**Table 52. Document revision history**

Date	Revision	Changes
06-Jun-2007	1	First draft.
20-Jul-07	2	<p><math>I_{DD}</math> values modified in <a href="#">Table 11: Maximum current consumption in Run and Sleep modes (TA = 85 °C)</a>.</p> <p><math>V_{BAT}</math> range modified in <a href="#">Power supply schemes</a>.</p> <p><math>V_{REF+}</math> min value, <math>t_{STAB}</math>, <math>t_{lat}</math> and <math>f_{TRIG}</math> added to <a href="#">Table 41: ADC characteristics</a>. <a href="#">Table 37: TIMx characteristics</a> modified.</p> <p><a href="#">Note 6</a> modified and <a href="#">Note 8</a>, <a href="#">Note 4</a> and <a href="#">Note 7</a> added below <a href="#">Table 4: Medium-density STM32F101xx pin definitions</a>.</p> <p><a href="#">Figure 18: Low-speed external clock source AC timing diagram</a>, <a href="#">Figure 10: Power supply scheme</a>, <a href="#">Figure 22: Recommended NRST pin protection</a> and <a href="#">Figure 23: I<sup>2</sup>C bus AC waveforms and measurement circuit<sup>(1)</sup></a> modified.</p> <p>Sample size modified and machine model removed in <a href="#">Electrostatic discharge (ESD)</a>.</p> <p>Number of parts modified and standard reference updated in <a href="#">Static latch-up</a>. 25 °C and 85 °C conditions removed and class name modified in <a href="#">Table 32: Electrical sensitivities</a>.</p> <p><math>t_{SU(LSE)}</math> changed to <math>t_{SU(LSE)}</math> in <a href="#">Table 21: HSE 4-16 MHz oscillator characteristics</a>.</p> <p>In <a href="#">Table 28: Flash memory endurance and data retention</a>, typical endurance added, data retention for <math>T_A = 25</math> °C removed and data retention for <math>T_A = 85</math> °C added. Note removed below <a href="#">Table 8: General operating conditions</a>.</p> <p><math>V_{BG}</math> changed to <math>V_{REFINT}</math> in <a href="#">Table 11: Embedded internal reference voltage</a>. <math>I_{DD}</math> max values added to <a href="#">Table 11: Maximum current consumption in Run and Sleep modes (TA = 85 °C)</a>.</p> <p><math>I_{DD(HSI)}</math> max value added to <a href="#">Table 23: HSI oscillator characteristics</a>.</p> <p><math>R_{PU}</math> and <math>R_{PD}</math> min and max values added to <a href="#">Table 33: I/O static characteristics</a>. <math>R_{PU}</math> min and max values added to <a href="#">Table 36: NRST pin characteristics</a> (two notes removed).</p> <p>Datasheet title corrected. USB characteristics section removed. <a href="#">Features on page 1</a> list optimized. Small text changes.</p>

Table 52. Document revision history (continued)

Date	Revision	Changes
18-Oct-2007	3	<p><math>V_{ESD(CDM)}</math> value added to <a href="#">Table 31: ESD absolute maximum ratings</a>.  Note added below <a href="#">Table 10: Embedded reset and power control block characteristics</a>. and below <a href="#">Table 21: HSE 4-16 MHz oscillator characteristics</a>.</p> <p>Note added below <a href="#">Table 34: Output voltage characteristics</a> and <math>V_{OH}</math> parameter description modified.  <a href="#">Table 41: ADC characteristics</a> and <a href="#">Table 43: ADC accuracy - limited test conditions</a> modified.  <a href="#">Figure 27: ADC accuracy characteristics</a> modified.  Packages are ECOPACK® compliant.  Tables modified in <a href="#">Section 5.3.5: Supply current characteristics</a>.  ADC and ANTI_TAMPER signal names modified (see <a href="#">Table 4: Medium-density STM32F101xx pin definitions</a>). <a href="#">Table 4: Medium-density STM32F101xx pin definitions</a> modified. Note 4 removed and values updated in <a href="#">Table 21: Typical current consumption in Standby mode</a>.  <math>V_{hys}</math> modified in <a href="#">Table 33: I/O static characteristics</a>.  Updated: <a href="#">Table 29: EMS characteristics</a> and <a href="#">Table 30: EMI characteristics</a>.</p> <p><math>t_{VDD}</math> modified in <a href="#">Table 9: Operating conditions at power-up / power-down</a>.  Typical values modified, note 2 modified and note 3 removed in <a href="#">Table 25: Low-power mode wakeup timings</a>.</p> <p>Maximum current consumption <a href="#">Table 12</a>, <a href="#">Table 13</a> and <a href="#">Table 14</a> updated.  Values added and notes added in <a href="#">Table 15: Typical and maximum current consumptions in Stop and Standby modes</a>.  <a href="#">On-chip peripheral current consumption on page 38</a> added.  Package mechanical data inch values are calculated from mm and rounded to 4 decimal digits (see <a href="#">Section 6: Package characteristics</a>).  <math>V_{prog}</math> added to <a href="#">Table 27: Flash memory characteristics</a>.  <math>T_{S\_temp}</math> added to <a href="#">Table 45: TS characteristics</a>.  <math>T_{S\_vrefint}</math> added to <a href="#">Table 11: Embedded internal reference voltage</a>.  Handling of unused pins specified in <a href="#">General input/output characteristics on page 48</a>. All I/Os are CMOS and TTL compliant.  <a href="#">Table 4: Medium-density STM32F101xx pin definitions</a>: table clarified and <a href="#">Note 7</a> modified.  Internal LSI RC frequency changed from 32 to 40 kHz (see <a href="#">Table 24: LSI oscillator characteristics</a>). Values added to <a href="#">Table 25: Low-power mode wakeup timings</a>. <math>N_{END}</math> modified in <a href="#">Table 28: Flash memory endurance and data retention</a>.  Option byte addresses corrected in <a href="#">Figure 7: Memory map</a>.  <math>ACC_{HSI}</math> modified in <a href="#">Table 23: HSI oscillator characteristics</a>.  <math>t_{JITTER}</math> removed from <a href="#">Table 26: PLL characteristics</a>.  <a href="#">Appendix A: Important notes on page 71</a> added.  Added: <a href="#">Figure 12</a>, <a href="#">Figure 13</a>, <a href="#">Figure 14</a> and <a href="#">Figure 16</a>.</p>

Table 52. Document revision history (continued)

Date	Revision	Changes
22-Nov-2007	4	<p>Document status promoted from preliminary data to datasheet. Small text changes.</p> <p>STM32F101CB part number corrected in <a href="#">Table 1: Device summary</a>.</p> <p>Number of communication peripherals corrected for STM32F101Tx in <a href="#">Table 2: Device features and peripheral counts (STM32F101xx Medium-density access line)</a> and Number of GPIOs corrected for LQFP package. <a href="#">Power supply schemes on page 11</a> modified.</p> <p>Main function and default alternate function modified for PC14 and PC15 in <a href="#">Table 4: Medium-density STM32F101xx pin definitions</a>, <a href="#">Note 5</a> added, Remap column added.</p> <p><a href="#">Figure 10: Power supply scheme</a> modified. <math>V_{DD} - V_{SS}</math> ratings modified and <a href="#">Note 1</a> modified in <a href="#">Table 5: Voltage characteristics</a>. <a href="#">Note 1</a> modified in <a href="#">Table 6: Current characteristics</a>.</p> <p><a href="#">Note 2</a> added in <a href="#">Table 10: Embedded reset and power control block characteristics</a>.</p> <p>48 and 72 MHz frequencies removed from <a href="#">Table 12</a>, <a href="#">Table 13</a> and <a href="#">Table 14</a>. MCU 's operating conditions modified in <a href="#">Typical current consumption on page 36</a>.</p> <p><math>I_{DD\_VBAT}</math> typical value at 2.4 V modified and <math>I_{DD\_VBAT}</math> maximum value added in <a href="#">Table 15: Typical and maximum current consumptions in Stop and Standby modes</a>. Note added in <a href="#">Table 16 on page 36</a> and <a href="#">Table 17 on page 37</a>. <a href="#">Table 18: Peripheral current consumption</a> modified.</p> <p><a href="#">Figure 15: Current consumption in Stop mode with regulator in Low-power mode versus temperature at <math>V_{DD} = 3.3\text{ V}</math> and <math>3.6\text{ V}</math></a> added.</p> <p>Note removed below <a href="#">Figure 24: SPI timing diagram - slave mode and <math>CPHA = 0</math></a>. Note added below <a href="#">Figure 25: SPI timing diagram - slave mode and <math>CPHA = 1^{(1)}</math></a>.</p> <p><a href="#">Figure 28: Typical connection diagram using the ADC</a> modified.</p> <p><math>t_{SU(HSE)}</math> and <math>t_{SU(LSE)}</math> conditions modified in <a href="#">Table 21</a> and <a href="#">Table 22</a>, respectively. Maximum values removed from <a href="#">Table 25: Low-power mode wakeup timings</a>. <math>t_{RET}</math> conditions modified in <a href="#">Table 28: Flash memory endurance and data retention</a>. Conditions modified in <a href="#">Table 29: EMS characteristics</a>.</p> <p>Impedance size specified in <a href="#">A.4: Voltage glitch on ADC input 0 on page 71</a>. Small text changes in <a href="#">Table 34: Output voltage characteristics</a>. <a href="#">Section 5.3.11: Absolute maximum ratings (electrical sensitivity)</a> updated.</p> <p>Details on unused pins removed from <a href="#">General input/output characteristics on page 48</a>.</p> <p><a href="#">Table 40: SPI characteristics</a> updated. Notes added and <math>I_{IKG}</math> removed in <a href="#">Table 41: ADC characteristics</a>. Note added in <a href="#">Table 42</a> and <a href="#">Table 45</a>. <a href="#">Note 3</a> and <a href="#">Note 2</a> added below <a href="#">Table 43: ADC accuracy - limited test conditions</a>. Avg_Slope and <math>V_{25}</math> modified in <a href="#">Table 45: TS characteristics</a>.</p> <p><math>\Theta_{JA}</math> value for VFQFPN36 package added in <a href="#">Table 50: Thermal characteristics</a>. <math>I^2C</math> interface characteristics on page 52 modified.</p> <p>Order codes replaced by <a href="#">Section 7: Ordering information scheme</a>.</p>

Table 52. Document revision history (continued)

Date	Revision	Changes
14-Mar-2008	5	<p><a href="#">Figure 2: Clock tree on page 16</a> added.</p> <p>CRC added (see <a href="#">CRC (cyclic redundancy check) calculation unit on page 9</a> and <a href="#">Figure 7: Memory map on page 24</a> for address).</p> <p>Maximum <math>T_J</math> value given in <a href="#">Table 7: Thermal characteristics on page 28</a>.</p> <p><math>P_D</math>, <math>T_A</math> and <math>T_J</math> added, <math>t_{prog}</math> values modified and <math>t_{prog}</math> description clarified in <a href="#">Table 27: Flash memory characteristics on page 45</a>.</p> <p><math>I_{DD}</math> modified in <a href="#">Table 15: Typical and maximum current consumptions in Stop and Standby modes on page 34</a>.</p> <p><math>ACC_{HSI}</math> modified in <a href="#">Table 23: HSI oscillator characteristics on page 43</a>, note 2 removed.</p> <p><math>t_{RET}</math> modified in <a href="#">Table 28: Flash memory endurance and data retention</a>.</p> <p><math>V_{NF(NRST)}</math> unit corrected in <a href="#">Table 36: NRST pin characteristics on page 51</a>.</p> <p><a href="#">Table 40: SPI characteristics on page 55</a> modified.</p> <p><math>I_{VREF}</math> added in <a href="#">Table 41: ADC characteristics on page 58</a>.</p> <p><a href="#">Table 43: ADC accuracy - limited test conditions</a> added. <a href="#">Table 44: ADC accuracy</a> modified.</p> <p>LQFP100 package specifications updated (see <a href="#">Section 6: Package characteristics on page 63</a>).</p> <p>Recommended LQFP100, LQFP64, LQFP48 and VFQFPN36 footprints added (see <a href="#">Figure 34</a>, <a href="#">Figure 36</a>, <a href="#">Figure 38</a> and <a href="#">Figure 32</a>).</p> <p><a href="#">Section 6.2: Thermal characteristics on page 68</a> modified.</p> <p><a href="#">Appendix A: Important notes</a> removed.</p>
21-Mar-2008	6	<p>Small text changes.</p> <p>In <a href="#">Table 28: Flash memory endurance and data retention</a>:</p> <ul style="list-style-type: none"> <li>– <math>N_{END}</math> tested over the whole temperature range</li> <li>– cycling conditions specified for <math>t_{RET}</math></li> <li>– <math>t_{RET}</math> min modified at <math>T_A = 55\text{ °C}</math></li> </ul> <p><a href="#">Figure 2: Clock tree</a> corrected. <a href="#">Figure 7: Memory map</a> clarified.</p> <p><math>V_{25}</math>, Avg_Slope and <math>T_L</math> modified in <a href="#">Table 45: TS characteristics</a>.</p> <p>CRC feature removed.</p>
22-May-2008	7	<p><a href="#">Section : Contents</a> modified, <a href="#">Section 2.2: Full compatibility throughout the family</a> added. CRC feature added.</p> <p><math>I_{DD\_VBAT}</math> removed from <a href="#">Table 21: Typical current consumption in Standby mode on page 42</a>.</p> <p>Values added to <a href="#">Table 39: SCL frequency (<math>f_{PCLK1} = 36\text{ MHz}</math>, <math>V_{DD} = 3.3\text{ V}</math>) on page 54</a>.</p> <p><a href="#">Figure 24: SPI timing diagram - slave mode and <math>CPHA = 0</math> on page 56</a> modified. <a href="#">Equation 1</a> corrected.</p> <p><a href="#">Section 6.2.2: Evaluating the maximum junction temperature for an application on page 69</a> added.</p> <p>Axx option added to <a href="#">Table 51: Ordering information scheme on page 70</a>.</p>

Table 52. Document revision history (continued)

Date	Revision	Changes
21-Jul-2008	8	<p>Small text changes.</p> <p><i>Power supply supervisor on page 11</i> modified and <math>V_{DDA}</math> added to <i>Table 8: General operating conditions on page 28</i>.</p> <p>Capacitance modified in <i>Figure 10: Power supply scheme on page 26</i>.</p> <p>Table notes revised in <i>Section 5: Electrical characteristics</i>.</p> <p>Maximum value of <math>t_{RSTTEMPO}</math> modified in <i>Table 10: Embedded reset and power control block characteristics on page 30</i>.</p> <p>Values added to <i>Table 15: Typical and maximum current consumptions in Stop and Standby modes</i> and <i>Table 21: Typical current consumption in Standby mode</i> removed.</p> <p><math>f_{HSE\_ext}</math> modified in <i>Table 19: High-speed external user clock characteristics on page 39</i>. <math>f_{PLL\_IN}</math> modified in <i>Table 26: PLL characteristics on page 44</i>.</p> <p><math>f_{HCLK}</math> corrected in <i>Table 29: EMS characteristics</i>.</p> <p>Minimum SDA and SCL fall time value for Fast mode removed from <i>Table 38: I<sup>2</sup>C characteristics on page 53</i>, note 1 modified.</p> <p><math>t_{h(NSS)}</math> modified in <i>Table 40: SPI characteristics on page 55</i> and <i>Figure 24: SPI timing diagram - slave mode and CPHA = 0 on page 56</i>.</p> <p><math>C_{ADC}</math> modified in <i>Table 41: ADC characteristics on page 58</i> and <i>Figure 28: Typical connection diagram using the ADC</i> modified.</p> <p><math>f_{PCLK2}</math> corrected in <i>Table 43: ADC accuracy - limited test conditions</i> and <i>Table 44: ADC accuracy</i>.</p> <p>Typical <math>T_{S\_temp}</math> value removed from <i>Table 45: TS characteristics on page 62</i>.</p> <p>LQFP48 package specifications updated (see <i>Table 49, Table 37</i> and <i>Table 38</i>).</p> <p>Axx option removed from <i>Table 51: Ordering information scheme on page 70</i>.</p>
24-Jul-2008	9	First page modified: "Up to 2 x I <sup>2</sup> C interfaces" instead of "1 x I <sup>2</sup> C interface"

**Please Read Carefully:**

Information in this document is provided solely in connection with ST products. STMicroelectronics NV and its subsidiaries ("ST") reserve the right to make changes, corrections, modifications or improvements, to this document, and the products and services described herein at any time, without notice.

All ST products are sold pursuant to ST's terms and conditions of sale.

Purchasers are solely responsible for the choice, selection and use of the ST products and services described herein, and ST assumes no liability whatsoever relating to the choice, selection or use of the ST products and services described herein.

No license, express or implied, by estoppel or otherwise, to any intellectual property rights is granted under this document. If any part of this document refers to any third party products or services it shall not be deemed a license grant by ST for the use of such third party products or services, or any intellectual property contained therein or considered as a warranty covering the use in any manner whatsoever of such third party products or services or any intellectual property contained therein.

**UNLESS OTHERWISE SET FORTH IN ST'S TERMS AND CONDITIONS OF SALE ST DISCLAIMS ANY EXPRESS OR IMPLIED WARRANTY WITH RESPECT TO THE USE AND/OR SALE OF ST PRODUCTS INCLUDING WITHOUT LIMITATION IMPLIED WARRANTIES OF MERCHANTABILITY, FITNESS FOR A PARTICULAR PURPOSE (AND THEIR EQUIVALENTS UNDER THE LAWS OF ANY JURISDICTION), OR INFRINGEMENT OF ANY PATENT, COPYRIGHT OR OTHER INTELLECTUAL PROPERTY RIGHT.**

**UNLESS EXPRESSLY APPROVED IN WRITING BY AN AUTHORIZED ST REPRESENTATIVE, ST PRODUCTS ARE NOT RECOMMENDED, AUTHORIZED OR WARRANTED FOR USE IN MILITARY, AIR CRAFT, SPACE, LIFE SAVING, OR LIFE SUSTAINING APPLICATIONS, NOR IN PRODUCTS OR SYSTEMS WHERE FAILURE OR MALFUNCTION MAY RESULT IN PERSONAL INJURY, DEATH, OR SEVERE PROPERTY OR ENVIRONMENTAL DAMAGE. ST PRODUCTS WHICH ARE NOT SPECIFIED AS "AUTOMOTIVE GRADE" MAY ONLY BE USED IN AUTOMOTIVE APPLICATIONS AT USER'S OWN RISK.**

Resale of ST products with provisions different from the statements and/or technical features set forth in this document shall immediately void any warranty granted by ST for the ST product or service described herein and shall not create or extend in any manner whatsoever, any liability of ST.

ST and the ST logo are trademarks or registered trademarks of ST in various countries.

Information in this document supersedes and replaces all information previously supplied.

The ST logo is a registered trademark of STMicroelectronics. All other names are the property of their respective owners.

© 2008 STMicroelectronics - All rights reserved

STMicroelectronics group of companies

Australia - Belgium - Brazil - Canada - China - Czech Republic - Finland - France - Germany - Hong Kong - India - Israel - Italy - Japan - Malaysia - Malta - Morocco - Singapore - Spain - Sweden - Switzerland - United Kingdom - United States of America

[www.st.com](http://www.st.com)