



STF2NK60Z - STQ2NK60ZR-AP STP2NK60Z - STD2NK60Z-1

N-CHANNEL 600V - 7.2Ω - 1.4A TO-220/TO-220FP/TO-92/IPAK
Zener-Protected SuperMESH™ MOSFET

Table 1: General Features

TYPE	V _{DSS}	R _{DS(on)}	I _D	P _w
STF2NK60Z	600 V	< 8 Ω	1.4 A	20
STQ2NK60ZR-AP	600 V	< 8 Ω	0.4 A	3 W
STP2NK60Z	600 V	< 8 Ω	1.4 A	45 W
STD2NK60Z-1	600 V	< 8 Ω	1.4 A	45 W

- TYPICAL R_{DS(on)} = 7.2 Ω
- EXTREMELY HIGH dv/dt CAPABILITY
- ESD IMPROVED CAPABILITY
- 100% AVALANCHE TESTED
- NEW HIGH VOLTAGE BENCHMARK
- GATE CHARGE MINIMIZED

DESCRIPTION

The SuperMESH™ series is obtained through an extreme optimization of ST's well established strip-based PowerMESH™ layout. In addition to pushing on-resistance significantly down, special care is taken to ensure a very good dv/dt capability for the most demanding applications. Such series complements ST full range of high voltage MOSFETs including revolutionary MDmesh™ products.

APPLICATIONS

- LOW POWER BATTERY CHARGERS
- SWITCH MODE LOW POWER SUPPLIES(SMPS)
- LOW POWER, BALLAST, CFL (COMPACT FLUORESCENT LAMPS)

Figure 1: Package

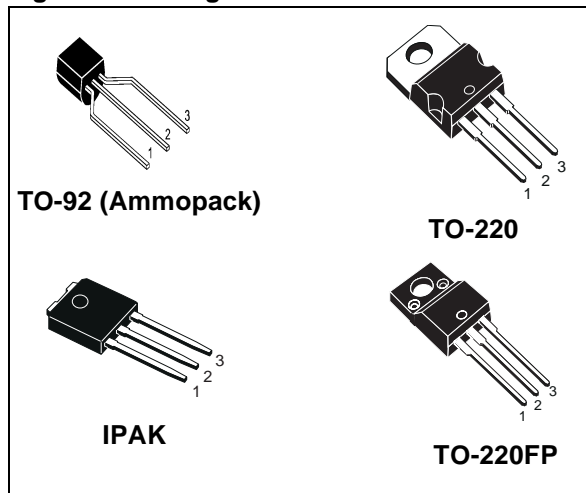


Figure 2: Internal Schematic Diagram

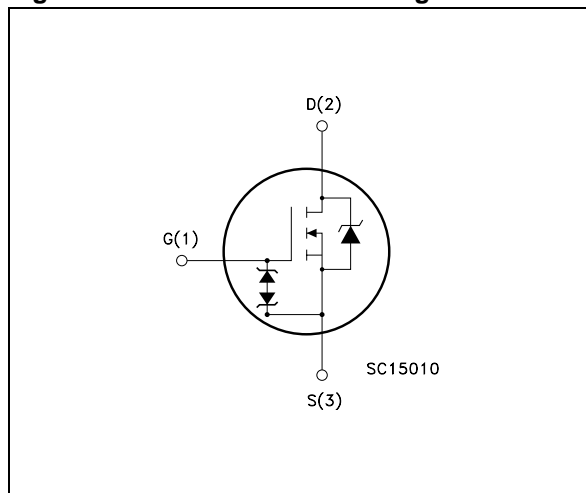


Table 2: Order Codes

Part Number	Marking	Package	Packaging
STQ2NK60ZR-AP	Q2NK60ZR	TO-92	AMMOPAK
STP2NK60Z	P2NK60Z	TO-220	TUBE
STD2NK60Z-1	D2NK60Z	IPAK	TUBE
STF2NK60Z	F2NK60Z	TO-220FP	TUBE

Table 3: Absolute Maximum ratings

Symbol	Parameter	Value			Unit
		TO-220 / IPAK	TO-92	TO-220FP	
V_{DS}	Drain-source Voltage ($V_{GS} = 0$)	600			V
V_{DGR}	Drain-gate Voltage ($R_{GS} = 20\text{ k}\Omega$)	600			V
V_{GS}	Gate- source Voltage	± 30			V
I_D	Drain Current (continuous) at $T_C = 25^\circ\text{C}$	1.4	0.4	1.4 (*)	A
I_D	Drain Current (continuous) at $T_C = 100^\circ\text{C}$	0.77	0.25	0.77 (*)	A
$I_{DM}(\bullet)$	Drain Current (pulsed)	5.6	1.6	5.6 (*)	A
P_{TOT}	Total Dissipation at $T_C = 25^\circ\text{C}$	45	3	20	W
	Derating Factor	0.36	0.025	0.16	W/ $^\circ\text{C}$
$V_{ESD(G-S)}$	Gate source ESD (HBM-C= 100pF, R=1.5k Ω)	1500			V
V_{ISO}	Insulation Withstand Voltage (DC)			2500	V
dv/dt (1)	Peak Diode Recovery voltage slope	4.5			V/ns
T_j T_{stg}	Operating Junction Temperature Storage Temperature	-55 to 150			$^\circ\text{C}$

(\bullet) Pulse width limited by safe operating area

(1) $I_{SD} \leq 1.4\text{A}$, $di/dt \leq 200\text{A}/\mu\text{s}$, $V_{DD} \leq V_{(BR)DSS}$, $T_j \leq T_{JMAX}$.

(*) Limited only by maximum temperature allowed

Table 4: Thermal Data

		TO-220/IPAK	TO-220FP	TO-92	Unit
Rthj-case	Thermal Resistance Junction-case Max	2.77	6.25	--	$^\circ\text{C}/\text{W}$
Rthj-amb	Thermal Resistance Junction-ambient Max	100	100	120	$^\circ\text{C}/\text{W}$
Rthj-lead	Thermal Resistance Junction-lead Max	--	--	40	$^\circ\text{C}/\text{W}$
T_l	Maximum Lead Temperature For Soldering Purpose	300		260	$^\circ\text{C}$

Table 5: Avalanche Characteristics

Symbol	Parameter	Max Value	Unit
I_{AR}	Avalanche Current, Repetitive or Not-Repetitive (pulse width limited by T_j max)	1.4	A
E_{AS}	Single Pulse Avalanche Energy (starting $T_j = 25^\circ\text{C}$, $I_D = I_{AR}$, $V_{DD} = 50\text{ V}$)	90	mJ

Table 6: Gate-Source Zener Diode

Symbol	Parameter	Test Conditions	Min.	Typ.	Max.	Unit
BV_{GSO}	Gate source Breakdown Voltage	$I_{GS} = \pm 1\text{ mA}$ (Open Drain)	30			V

PROTECTION FEATURES OF GATE-TO-SOURCE ZENER DIODES

The built-in back-to-back Zener diodes have specifically been designed to enhance not only the device's ESD capability, but also to make them safely absorb possible voltage transients that may occasionally be applied from gate to source. In this respect the Zener voltage is appropriate to achieve an efficient and cost-effective intervention to protect the device's integrity. These integrated Zener diodes thus avoid the usage of external components.

ELECTRICAL CHARACTERISTICS ($T_{CASE} = 25^{\circ}C$ UNLESS OTHERWISE SPECIFIED)

Table 7: On/Off

Symbol	Parameter	Test Conditions	Min.	Typ.	Max.	Unit
$V_{(BR)DSS}$	Drain-source Breakdown Voltage	$I_D = 1mA, V_{GS} = 0$	600			V
I_{DSS}	Zero Gate Voltage Drain Current ($V_{GS} = 0$)	$V_{DS} = \text{Max Rating}$ $V_{DS} = \text{Max Rating}, T_C = 125^{\circ}C$			1 50	μA μA
I_{GSS}	Gate-body Leakage Current ($V_{DS} = 0$)	$V_{GS} = \pm 20V$			± 10	μA
$V_{GS(th)}$	Gate Threshold Voltage	$V_{DS} = V_{GS}, I_D = 50 \mu A$	3	3.75	4.5	V
$R_{DS(on)}$	Static Drain-source On Resistance	$V_{GS} = 10V, I_D = 0.7 A$		7.2	8	Ω

Table 8: Dynamic

Symbol	Parameter	Test Conditions	Min.	Typ.	Max.	Unit
$g_{fs} (1)$	Forward Transconductance	$V_{DS} = 15 V, I_D = 0.7 A$		1		S
C_{iss} C_{oss} C_{rSS}	Input Capacitance Output Capacitance Reverse Transfer Capacitance	$V_{DS} = 25V, f = 1 \text{ MHz}, V_{GS} = 0$		170 27 5		pF pF pF
$C_{oss \text{ eq.}} (3)$	Equivalent Output Capacitance	$V_{GS} = 0V, V_{DS} = 0V \text{ to } 480V$		30		pF
$t_{d(on)}$ t_r $t_{d(off)}$ t_f	Turn-on Delay Time Rise Time Turn-off Delay Time Fall Time	$V_{DD} = 300 V, I_D = 0.65 A,$ $R_G = 4.7 \Omega, V_{GS} = 10 V$ (Resistive Load see, Figure 22)		8 30 22 55		ns ns ns ns
Q_g Q_{gs} Q_{gd}	Total Gate Charge Gate-Source Charge Gate-Drain Charge	$V_{DD} = 480V, I_D = 1.5 A,$ $V_{GS} = 10V$ (see, Figure 24)		7.7 1.7 4	10	nC nC nC

Table 9: Source Drain Diode

Symbol	Parameter	Test Conditions	Min.	Typ.	Max.	Unit
I_{SD} $I_{SDM} (2)$	Source-drain Current Source-drain Current (pulsed)				1.5 6	A A
$V_{SD} (1)$	Forward On Voltage	$I_{SD} = 1.5 A, V_{GS} = 0$			1.6	V
t_{rr} Q_{rr} I_{RRM}	Reverse Recovery Time Reverse Recovery Charge Reverse Recovery Current	$I_{SD} = 1.3 A, di/dt = 100 A/\mu s$ $V_{DD} = 25V, T_j = 25^{\circ}C$ (see test circuit, Figure 23)		250 550 4.4		ns μC A
t_{rr} Q_{rr} I_{RRM}	Reverse Recovery Time Reverse Recovery Charge Reverse Recovery Current	$I_{SD} = 1.3 A, di/dt = 100 A/\mu s$ $V_{DD} = 25V, T_j = 150^{\circ}C$ (see test circuit, Figure 23)		300 690 4.6		ns μC A

(1) Pulsed: Pulse duration = 300 μs , duty cycle 1.5 %.

(2) Pulse width limited by safe operating area.

(3) $C_{oss \text{ eq.}}$ is defined as a constant equivalent capacitance giving the same charging time as C_{oss} when V_{DS} increases from 0 to 80% V_{DSS}

Figure 3: Safe Operating Area For TO-220

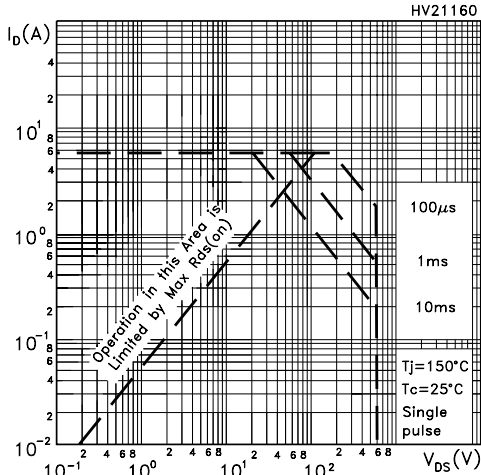


Figure 4: Safe Operating Area For IPAK

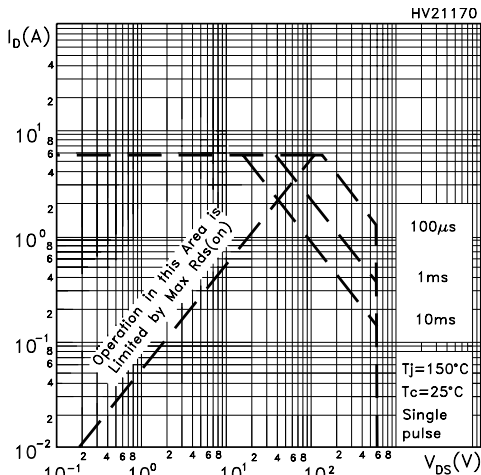


Figure 5: Safe Operating Area For TO-92

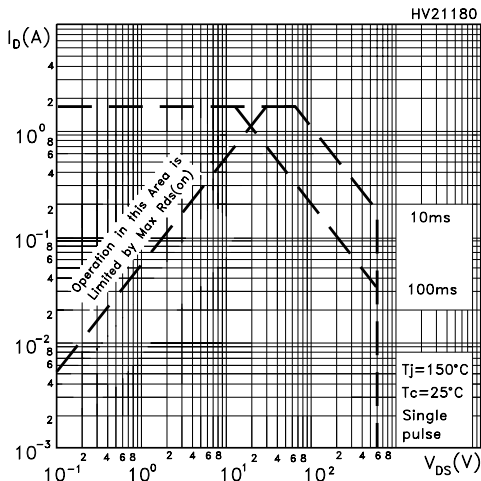


Figure 6: Thermal Impedance For TO-220

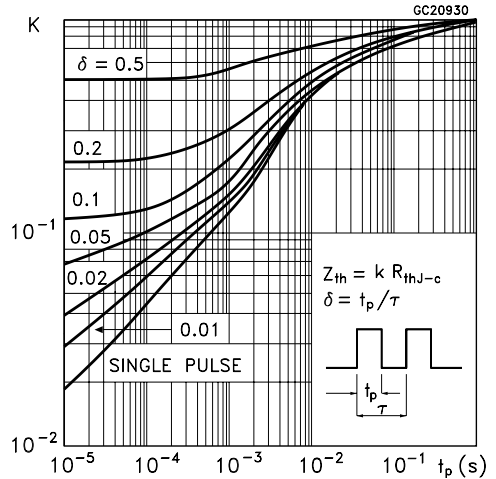


Figure 7: Thermal Impedance For IPAK

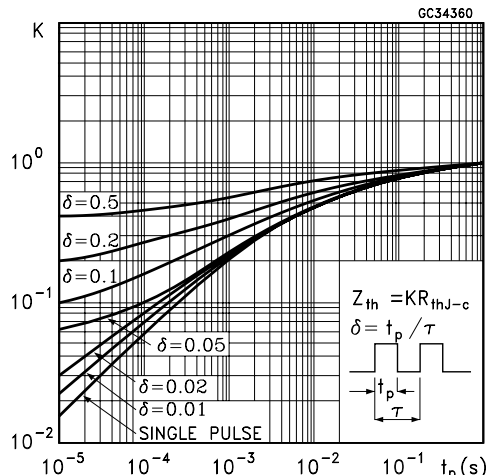


Figure 8: Thermal Impedance For TO-92

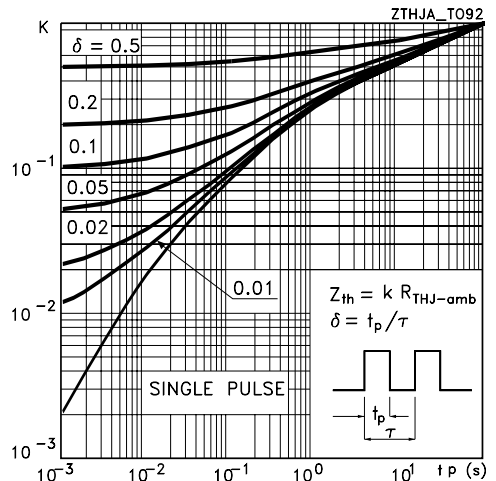


Figure 9: Safe Operating Area For TO-220FP

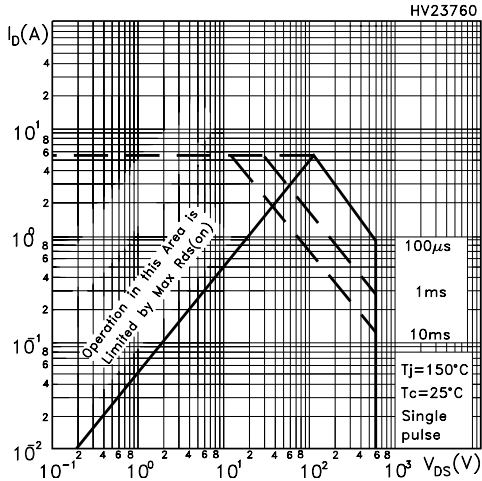


Figure 10: Output Characteristics

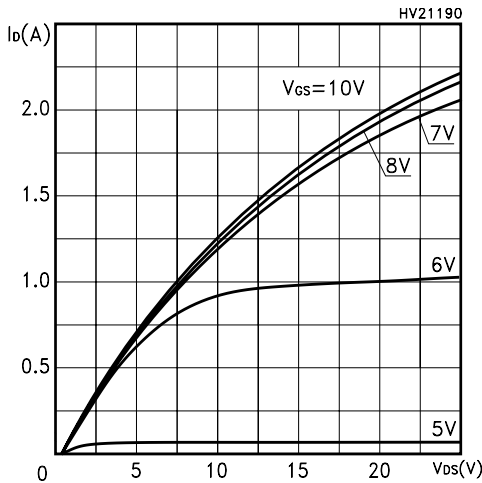


Figure 11: Transconductance

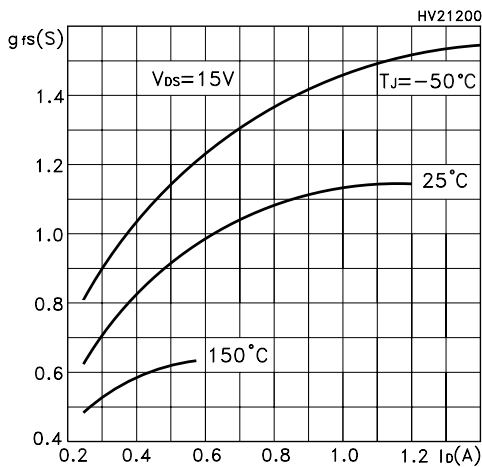


Figure 12: Thermal Impedance For TO-220FP

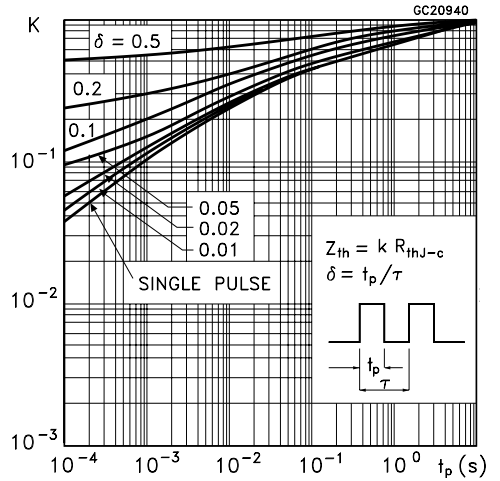


Figure 13: Transfer Characteristics

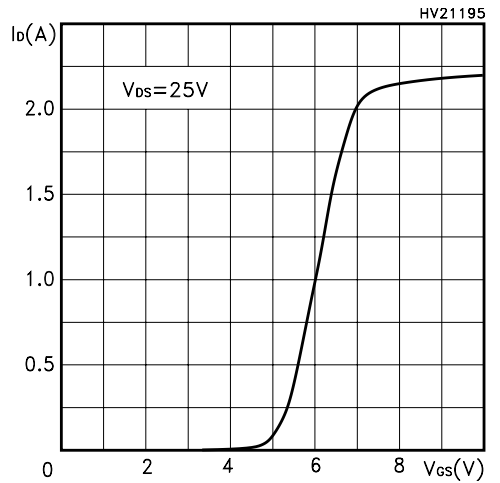


Figure 14: Gate Charge vs Gate-source Voltage

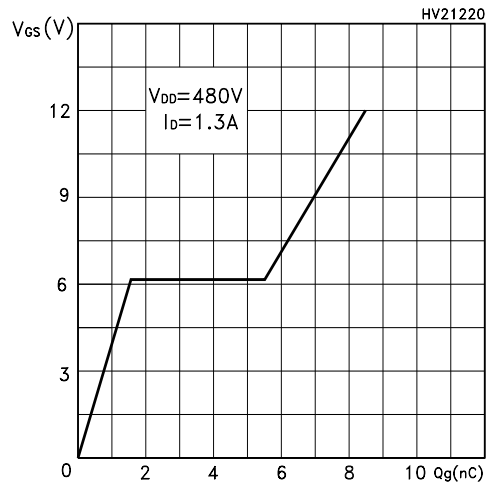


Figure 15: Static Drain-source On Resistance

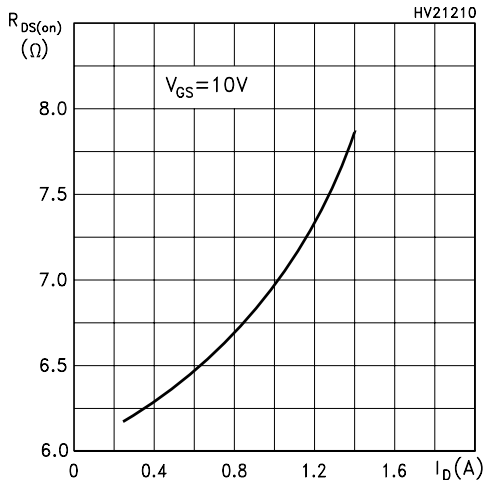


Figure 16: Capacitance Variations

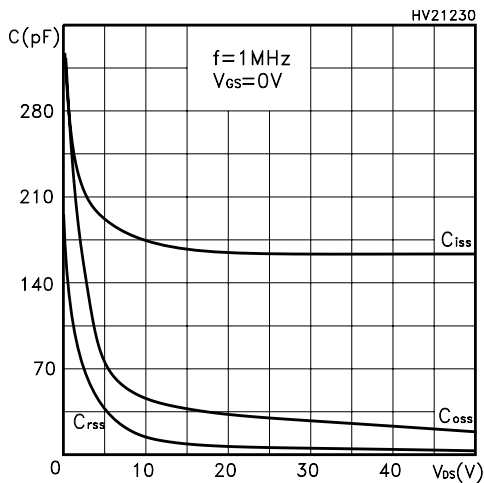


Figure 17: Normalized Gate Threshold Voltage vs Temperature

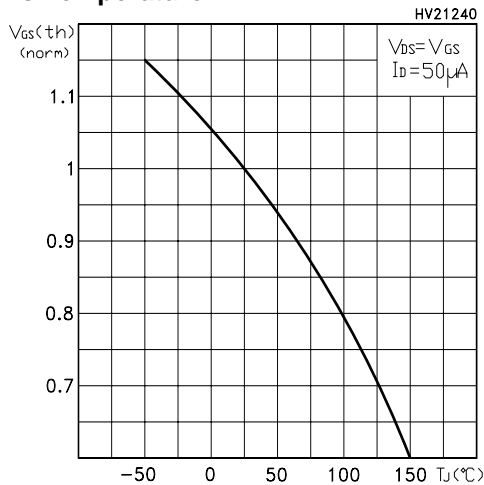


Figure 18: Source-Drain Forward Characteristics

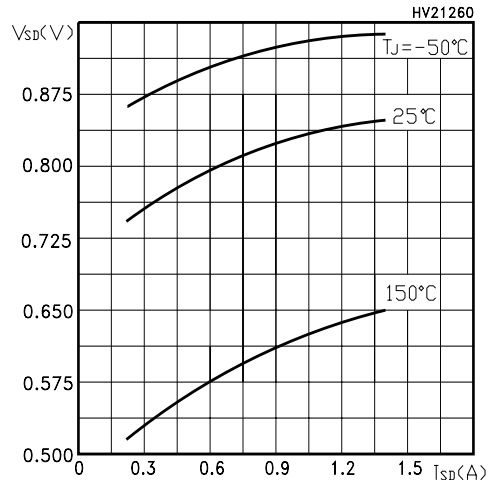


Figure 19: Maximum Avalanche Energy vs Temperature

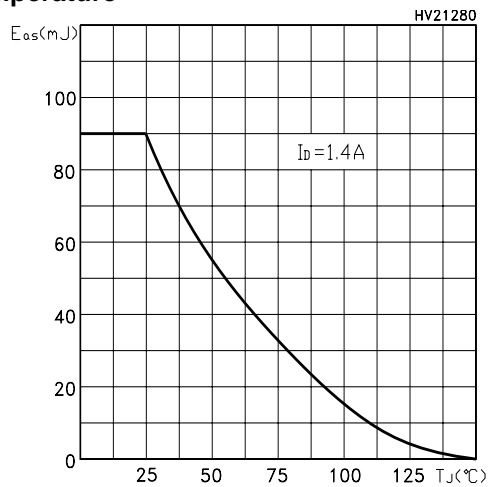


Figure 20: Normalized On Resistance vs Temperature

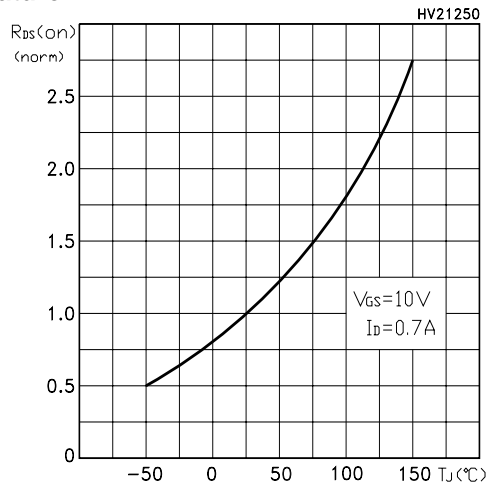


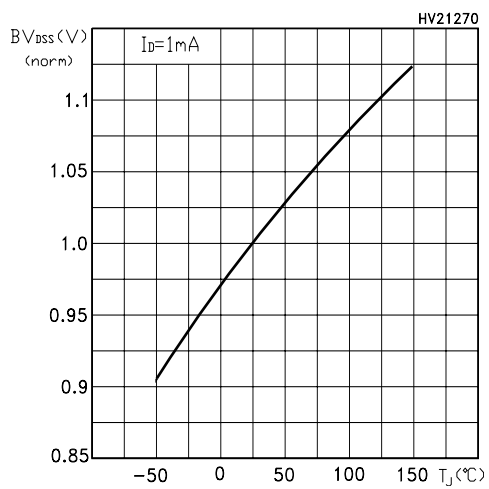
Figure 21: Normalized BV_{DSS} vs Temperature

Figure 22: Switching Times Test Circuit For Resistive Load

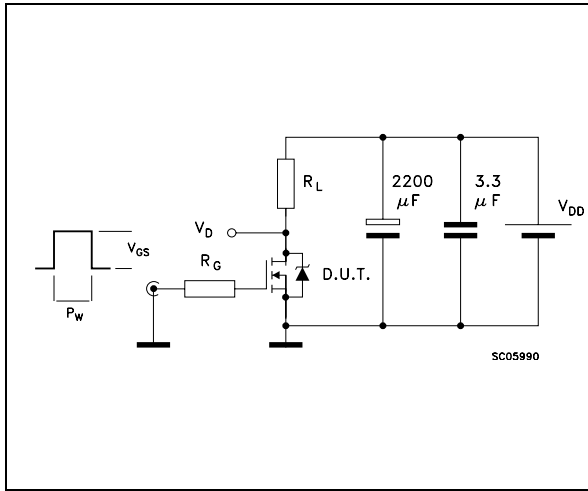


Figure 24: Gate Charge Test Circuit

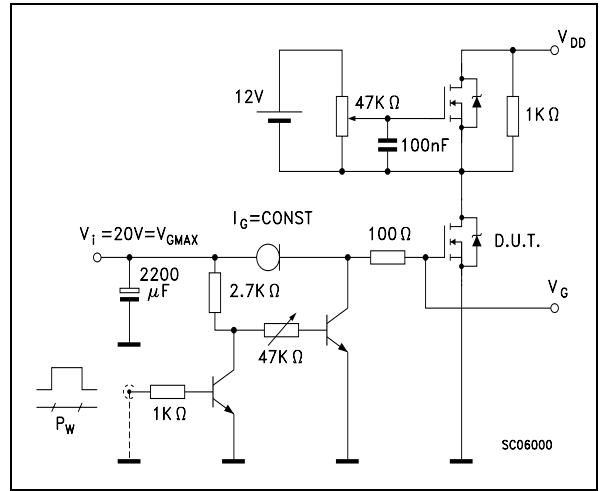
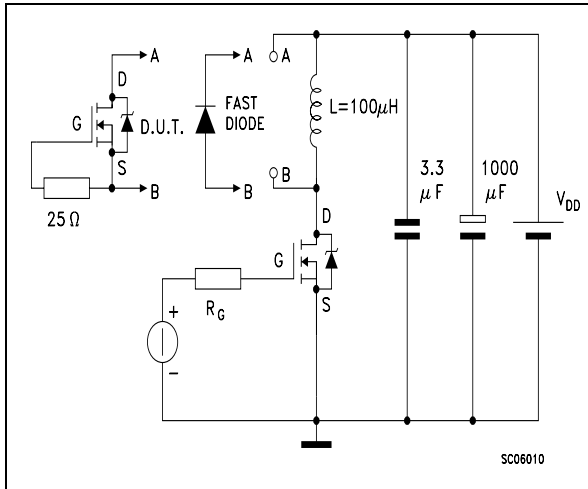
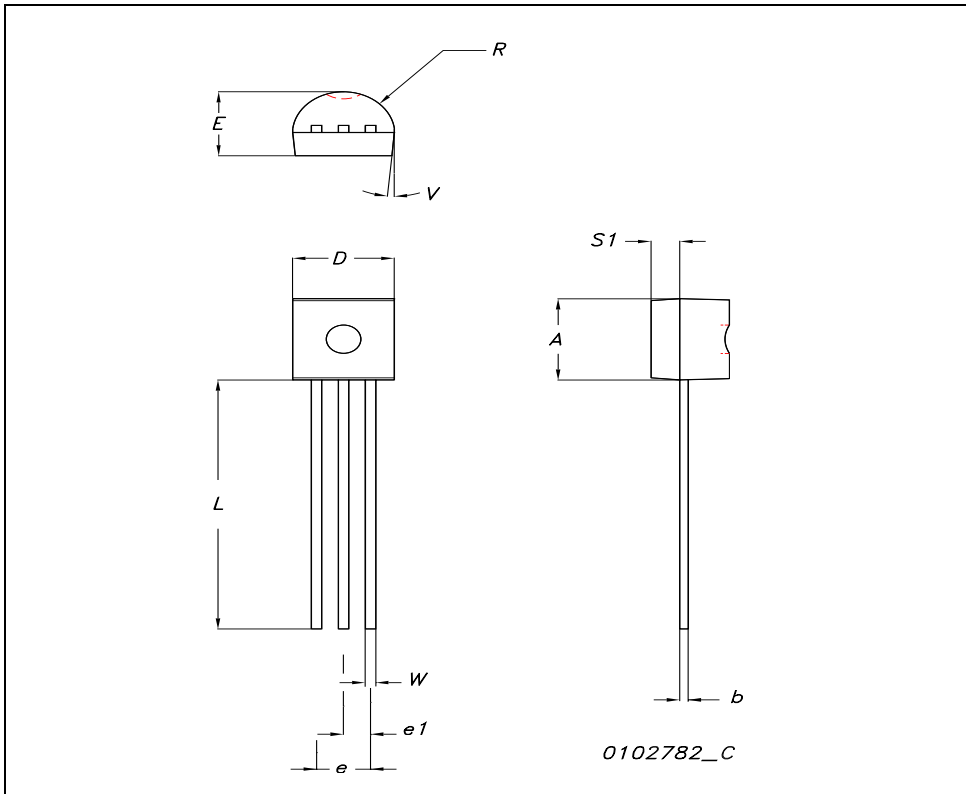


Figure 23: Test Circuit For Inductive Load Switching and Diode Recovery Times



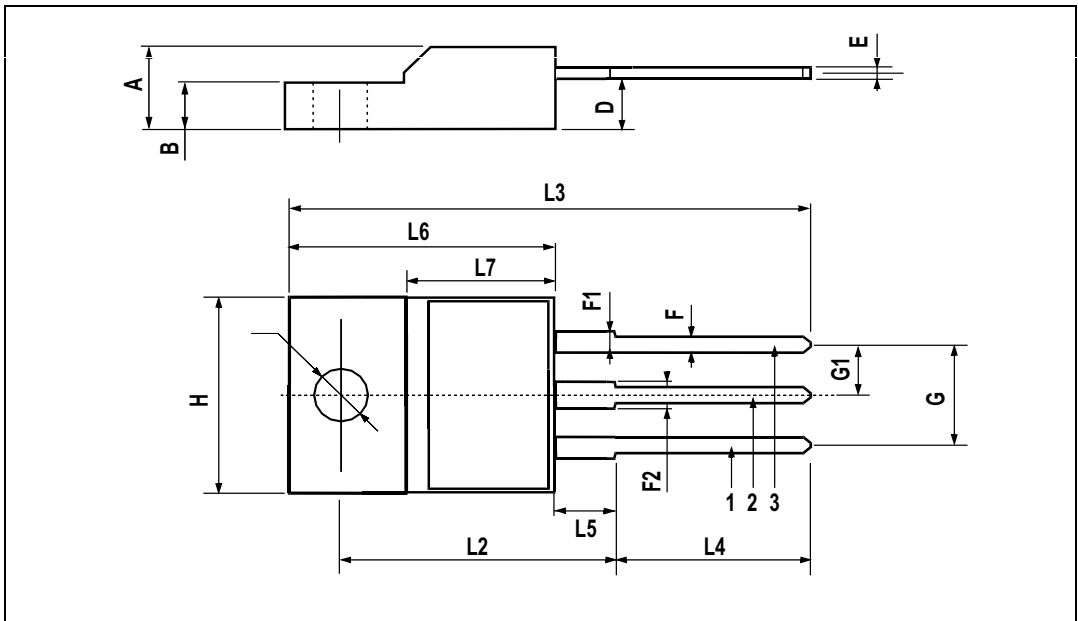
TO-92 MECHANICAL DATA

DIM.	mm.			inch		
	MIN.	TYP.	MAX.	MIN.	TYP.	MAX.
A	4.32		4.95	0.170		0.194
b	0.36		0.51	0.014		0.020
D	4.45		4.95	0.175		0.194
E	3.30		3.94	0.130		0.155
e	2.41		2.67	0.094		0.105
e1	1.14		1.40	0.044		0.055
L	12.70		15.49	0.50		0.610
R	2.16		2.41	0.085		0.094
S1	0.92		1.52	0.036		0.060
W	0.41		0.56	0.016		0.022
V		5°			5°	



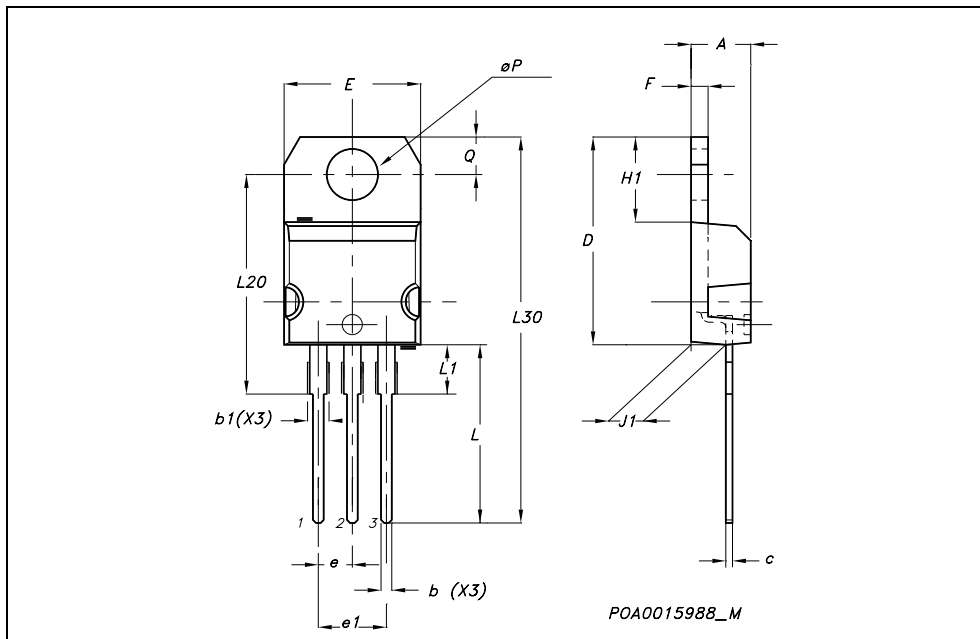
TO-220FP MECHANICAL DATA

DIM.	mm.			inch		
	MIN.	TYP	MAX.	MIN.	TYP.	MAX.
A	4.4		4.6	0.173		0.181
B	2.5		2.7	0.098		0.106
D	2.5		2.75	0.098		0.108
E	0.45		0.7	0.017		0.027
F	0.75		1	0.030		0.039
F1	1.15		1.7	0.045		0.067
F2	1.15		1.7	0.045		0.067
G	4.95		5.2	0.195		0.204
G1	2.4		2.7	0.094		0.106
H	10		10.4	0.393		0.409
L2		16			0.630	
L3	28.6		30.6	1.126		1.204
L4	9.8		10.6	.0385		0.417
L5	2.9		3.6	0.114		0.141
L6	15.9		16.4	0.626		0.645
L7	9		9.3	0.354		0.366
∅	3		3.2	0.118		0.126



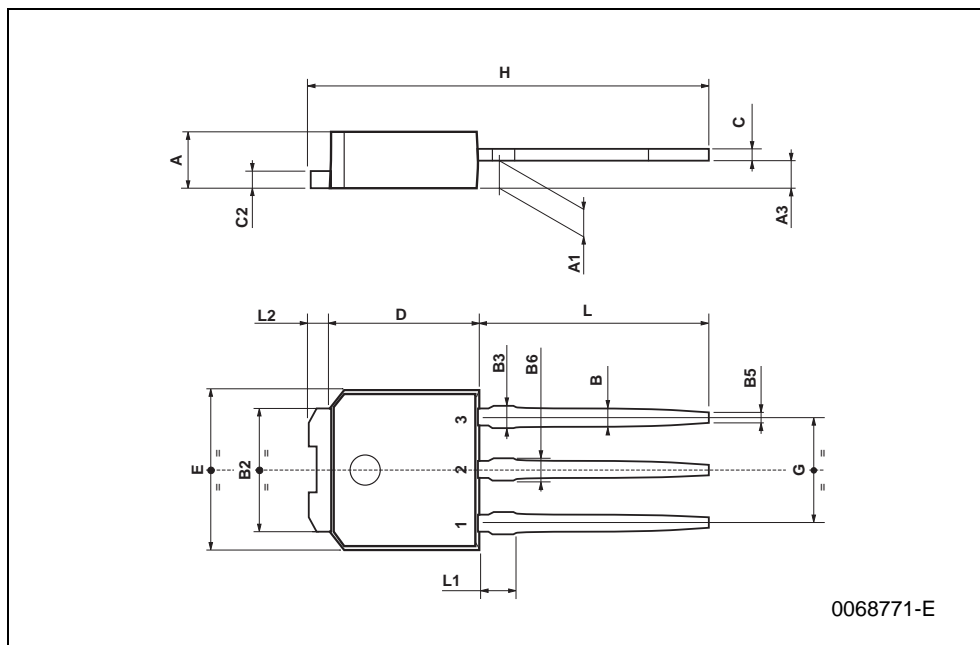
TO-220 MECHANICAL DATA

DIM.	mm.			inch		
	MIN.	TYP.	MAX.	MIN.	TYP.	MAX.
A	4.40		4.60	0.173		0.181
b	0.61		0.88	0.024		0.034
b1	1.15		1.70	0.045		0.066
c	0.49		0.70	0.019		0.027
D	15.25		15.75	0.60		0.620
E	10		10.40	0.393		0.409
e	2.40		2.70	0.094		0.106
e1	4.95		5.15	0.194		0.202
F	1.23		1.32	0.048		0.052
H1	6.20		6.60	0.244		0.256
J1	2.40		2.72	0.094		0.107
L	13		14	0.511		0.551
L1	3.50		3.93	0.137		0.154
L20		16.40			0.645	
L30		28.90			1.137	
øP	3.75		3.85	0.147		0.151
Q	2.65		2.95	0.104		0.116



TO-251 (IPAK) MECHANICAL DATA

DIM.	mm			inch		
	MIN.	TYP.	MAX.	MIN.	TYP.	MAX.
A	2.2		2.4	0.086		0.094
A1	0.9		1.1	0.035		0.043
A3	0.7		1.3	0.027		0.051
B	0.64		0.9	0.025		0.031
B2	5.2		5.4	0.204		0.212
B3			0.85			0.033
B5		0.3			0.012	
B6			0.95			0.037
C	0.45		0.6	0.017		0.023
C2	0.48		0.6	0.019		0.023
D	6		6.2	0.236		0.244
E	6.4		6.6	0.252		0.260
G	4.4		4.6	0.173		0.181
H	15.9		16.3	0.626		0.641
L	9		9.4	0.354		0.370
L1	0.8		1.2	0.031		0.047
L2		0.8	1		0.031	0.039



TO-92 AMMOPACK

DIM.	mm.			inch		
	MIN.	TYP	MAX.	MIN.	TYP.	MAX.
A1	4.45		4.95	0.170		0.194
T	3.30		3.94	0.130		0.155
T1			1.6			0.06
T2			2.3			0.09
d	0.41		0.56	0.016		0.022
P0	12.5	12.7	12.9	0.49	0.5	0.51
P2	5.65	6.35	7.05	0.22	0.25	0.27
F1, F2	2.44	2.54	2.94	0.09	0.1	0.11
delta H	-2		2	-0.08		0.08
W	17.5	18	19	0.69	0.71	0.74
W0	5.7	6	6.3	0.22	0.23	0.24
W1	8.5	9	9.25	0.33	0.35	0.36
W2			0.5			0.02
H	18.5		20.5	0.72		0.80
H0	15.5	16	16.5	0.61	0.63	0.65
H1			25			0.98
D0	3.8	4	4.2	0.15	0.157	0.16
t			0.9			0.035
L			11			0.43
l1	3			0.11		
delta P	-1		1	-0.04		0.04

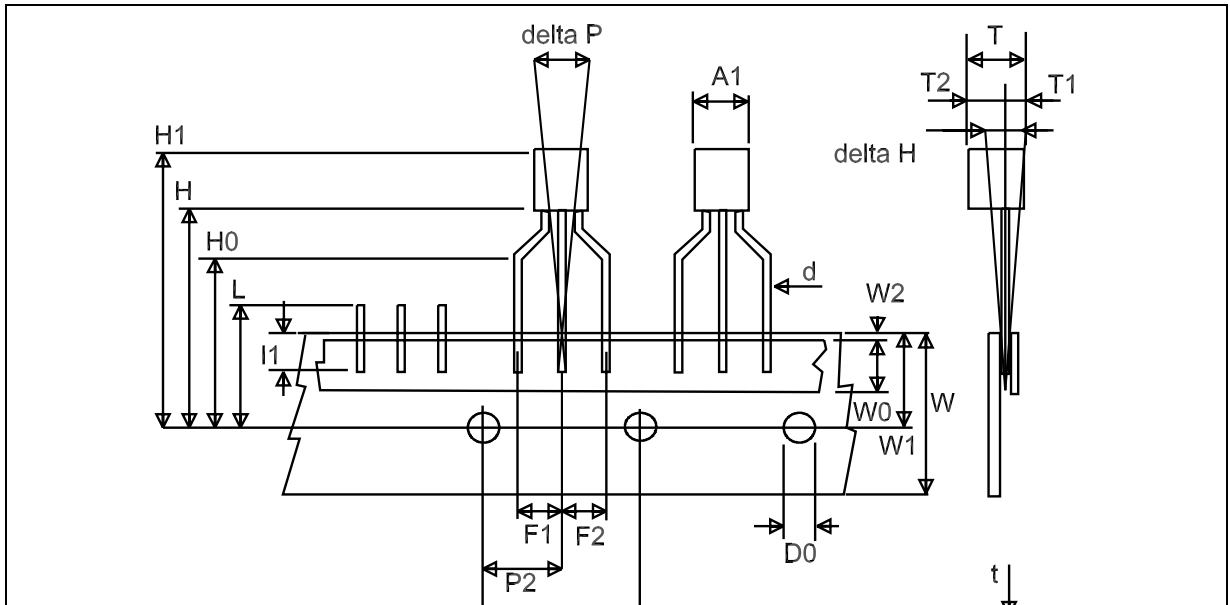


Table 10: Revision History

Date	Revision	Description of Changes
07-Jul-2004	3	The document change from "TARGET" to "COMPLETE" New stylesheet
11/Nov/2004	4	Added TO-220FP

Information furnished is believed to be accurate and reliable. However, STMicroelectronics assumes no responsibility for the consequences of use of such information nor for any infringement of patents or other rights of third parties which may result from its use. No license is granted by implication or otherwise under any patent or patent rights of STMicroelectronics. Specifications mentioned in this publication are subject to change without notice. This publication supersedes and replaces all information previously supplied. STMicroelectronics products are not authorized for use as critical components in life support devices or systems without express written approval of STMicroelectronics.

The ST logo is a registered trademark of STMicroelectronics

All other names are the property of their respective owners

© 2004 STMicroelectronics - All Rights Reserved

STMicroelectronics group of companies

Australia - Belgium - Brazil - Canada - China - Czech Republic - Finland - France - Germany - Hong Kong - India - Israel - Italy - Japan - Malaysia - Malta - Morocco - Singapore - Spain - Sweden - Switzerland - United Kingdom - United States of America

This datasheet has been download from:

www.datasheetcatalog.com

Datasheets for electronics components.