



ST3243E

±15KV ESD protected 3 to 5.5V, 400Kbps, RS-232 Transceiver
with auto-powerdown

General features

- ESD protection for RS-232 I/O pins:
 - ±8kV IEC 1000-4-2 contact discharge
 - ±15kV human body model
- 1µA supply current achieved when in auto-powerdown
- 250Kbps minimum guaranteed data rate
- Guaranteed 6V/ms slew rate range
- Guaranteed mouse driveability
- 0.1µF external capacitors
- Meet EIA/TIA-232 specifications down to 3V
- Available in SO-28, SSOP-28, TSSOP28 and flip-chip28 packages

Description

The ST3243E device consists of 3 drivers, 5 receivers and a dual charge-pump circuit. The device meets the requirements of EIA/TIA and V.28/V.24 communication standards providing high data rate capability and enhanced electrostatic discharge (ESD) protection. All transmitter outputs and receiver input are protected to ±8KV USING IEC 1000-4-2 contact discharge and ±15KV using the Human Body Model. The receiver R2 is always active to implement a wake-up feature for serial port.

The ST3243E has a proprietary low-dropout transmitter output stage enabling true RS-232 performance from a 3.0V to 5.5V supply with a dual charge pump. The device is guaranteed to run at data rates of 250kbps while maintaining RS-232 output levels.

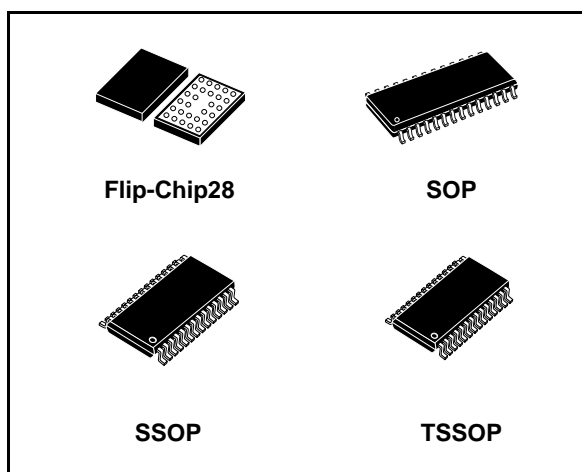

The Auto-powerdown feature functions when FORCEON is low and FORCEOFF is high. During this mode of operation, if the device does not sense a valid RS-232 signal, the driver outputs are disabled. If FORCEOFF is set low, both drivers and receivers (except R2B) are shut off, and supply current is reduced to 1µA. Disconnecting the serial port or turning off the peripheral drives causes the auto-powerdown condition to occur.

Auto-powerdown can be disabled when FORCEON and FORCEOFF are high, and should be done when driving a serial mouse. With Auto-powerdown enabled, the device is activated automatically when a valid signal is applied to any receiver input.

Typical applications are in notebook, subnotebook, palmtop computers, battery-powered equipment, hand-held equipment, peripherals and printers.

Contents

1	Pin configuration	3
2	Truth tables	6
3	Maximum ratings	7
4	Electrical characteristics	8
5	Application circuits	11
6	Timing diagrams	12
7	Package mechanical data	13
8	Order code	22
9	Revision history	23

1 Pin configuration

Figure 1. Pin configuration

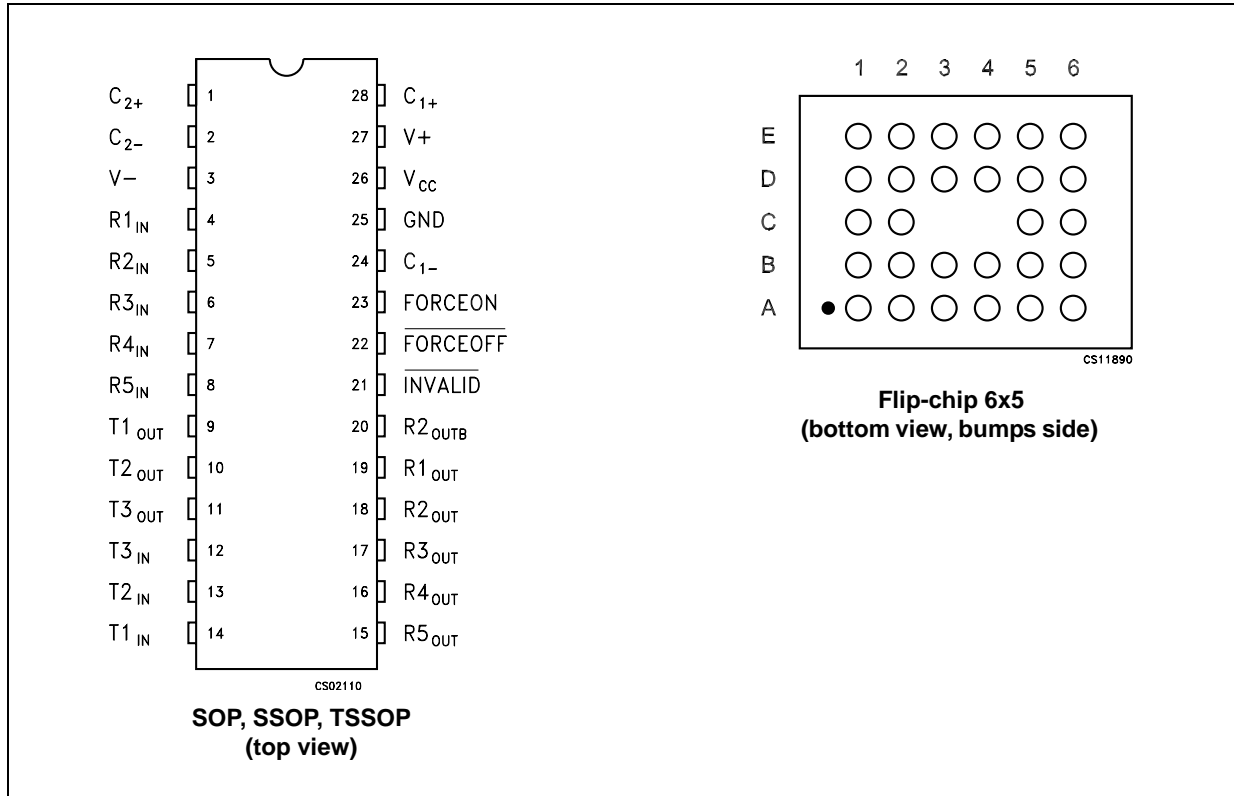

Table 1. Pin description (for SOP, SSOP and TSSOP)

Pin n°	Symbol	Name and function
1	C ₂₊	Positive terminal of inverting charge pump capacitor
2	C ₂₋	Negative terminal of inverting charge pump capacitor
3	V-	-5.5V Generated by the charge pump
4	R1 _{IN}	First receiver input voltage
5	R2 _{IN}	Second receiver input voltage
6	R3 _{IN}	Third receiver input voltage
7	R4 _{IN}	Fourth receiver input voltage
8	R5 _{IN}	Fifth receiver input voltage
9	T1 _{OUT}	First transmitter output voltage
10	T2 _{OUT}	Second transmitter output voltage
11	T3 _{OUT}	Third transmitter output voltage
12	T3 _{IN}	Third transmitter input voltage
13	T2 _{IN}	Second transmitter input voltage
14	T1 _{IN}	First transmitter input voltage
15	R5 _{OUT}	Fifth receiver output voltage
16	R4 _{OUT}	Fourth receiver output voltage
17	R3 _{OUT}	Third receiver output voltage
18	R2 _{OUT}	Second receiver output voltage
19	R1 _{OUT}	First receiver output voltage
20	R2 _{OUTB}	Non-inverting complementary receiver output, always active for wake-up
21	INVALID	Output of the valid signal detector. Indicates if a valid RS-232 level is present on receiver inputs logic "1"
22	FORCEOFF	Drive low to shut down transmitters and on-board power supply. This over-rides all automatic circuitry and FORCEON
23	FORCEON	Drive high to override automatic circuitry keeping transmitters on ($\overline{\text{FORCEOFF}}$ must be high)
24	C ₁₋	Negative terminal of voltage-charge pump capacitor
25	GND	Ground
26	V _{CC}	Supply voltage
27	V+	5.5V Generated by the charge pump
28	C ₁₊	Positive terminal of voltage-charge pump capacitor

Table 2. Pin description (for Flip-chip)

Pin n°	Symbol	Name and function
A1	R2 _{IN}	Second receiver input voltage
A2	R3 _{IN}	Third receiver input voltage
A3	R4 _{IN}	Fourth receiver input voltage
A4	R5 _{IN}	Fifth receiver input voltage
A5	T1 _{OUT}	First transmitter output voltage
A6	T2 _{OUT}	Second transmitter output voltage
B1	V-	-5.5V Generated by the charge pump
B2	R1 _{IN}	First receiver input voltage
B3	T3 _{OUT}	Third transmitter output voltage
B4	T3 _{IN}	Third transmitter input voltage
B5	T1 _{IN}	First transmitter input voltage
B6	T2 _{IN}	Second transmitter input voltage
C1	C ₂₊	Positive terminal of inverting charge pump capacitor
C2	C ₂₋	Negative terminal of inverting charge pump capacitor
C5	R4 _{OUT}	Fourth receiver output voltage
C6	R5 _{OUT}	Fifth receiver output voltage
D1	C ₁₊	Positive terminal of voltage- charge pump capacitor
D2	V+	5.5V Generated by the charge pump
D3	V _{CC}	Supply voltage
D4	FORCEON	Drive high to override automatic circuitry keeping transmitters on (FORCEOFF must be high)
D5	R1 _{OUT}	First receiver output voltage
D6	R3 _{OUT}	Third receiver output voltage
E1	GND	Ground
E2	C ₁₋	Negative terminal of voltage- charge pump capacitor
E3	FORCEOFF	Drive low to shut down transmitters and on-board power supply. This over-rides all automatic circuitry and FORCEON
E4	INVALID	Output of the valid signal detector. Indicates if a valid RS-232 level is present on receiver inputs logic "1"
E5	R2 _{OUTB}	Non-inverting complementary receiver output, always active for wake-up
E6	R2 _{OUT}	Second receiver output voltage

2 Truth tables

Table 3. Invalid truth table

RS-232 Signal present at any receiver input	$\overline{\text{INVALID}}$ output
YES	H
NO	L

Table 4. Output control truth table

FORCE ON	FORCE OFF	Valid receiver level	Operation status	T _{OUT}	R _{OUT}	R _{2OUTB}
X	0	X	Shutdown (Force OFF)	HIGH Z	HIGH Z	ACTIVE
1	1	X	Normal operating (Force ON)	ACTIVE	ACTIVE	ACTIVE
0	1	YES	Normal operating (Auto-powerdown)	ACTIVE	ACTIVE	ACTIVE
0	1	NO	Shutdown (Auto-powerdown)	HIGH Z	ACTIVE	ACTIVE

3 Maximum ratings

Table 5. Absolute maximum ratings

Symbol	Parameter	Value	Unit
V_{CC}	Supply voltage	-0.3 to 6	V
V+	Doubled voltage terminal	$(V_{CC} - 0.3)$ to 7	V
V-	Inverted voltage terminal	0.3 to -7	V
$V+ + V- $		13	V
$\overline{FORCEON}$, $\overline{FORCEOFF}$, T_{IN}	Input voltage	-0.3 to 6	V
R_{IN}	Receiver input voltage range	± 25	V
T_{OUT}	Transmitter output voltage range	± 13.2	V
R_{OUT} R_{OUTB} INVALID	Receiver output voltage range	-0.3 to $(V_{CC} + 0.3)$	V
t_{SHORT}	Short circuit duration on T_{OUT} (one at a time)	Continuous	
T_{stg}	Storage temperature range	-65 to 150	°C

Note: Absolute Maximum Ratings are those values beyond which damage to the device may occur. Functional operation under these condition is not implied.

Table 6. ESD Performance: transmitter outputs, receiver inputs

Symbol	Parameter	Test Conditions	Min.	Typ.	Max.	Unit
ESD	ESD Protection voltage	Human body model	± 15			KV
ESD	ESD Protection voltage	IEC 1000-4-2 (contact discharge)	± 8			KV

4 Electrical characteristics

Table 7. Electrical characteristics

(C1 - C4 = 0.1µF, V_{CC} = 3V to 5.5V, T_A = -40 to 85°C, unless otherwise specified.
Typical values are referred to T_A = 25°C)

Symbol	Parameter	Test Conditions	Min.	Typ.	Max.	Unit
I _{ASHDN}	Supply current auto-powerdown	$\overline{\text{FORCEOFF}} = \text{GND}, \overline{\text{FORCEON}} = V_{\text{CC}}$ All R_IN open or grounded		1	10	µA
I _{SUPPLY}	Supply current	$\overline{\text{FORCEON}} = \overline{\text{FORCEOFF}} = V_{\text{CC}}$		0.3	1	mA
I _{SHDN}	Shutdown supply current	$\overline{\text{FORCEOFF}} = \text{GND}$		1	10	µA

Table 8. Logic input electrical characteristics

(C1 - C4 = 0.1µF, V_{CC} = 3V to 5.5V, T_A = -40 to 85°C, unless otherwise specified.
Typical values are referred to T_A = 25°C)

Symbol	Parameter	Test Conditions	Min.	Typ.	Max.	Unit
V _{TIL}	Input logic threshold low	T-IN, FORCEON, $\overline{\text{FORCEOFF}}$			0.8	V
V _{TIH}	Input logic threshold high	T-IN, FORCEON, $\overline{\text{FORCEOFF}}$ V _{CC} = 3.3V V _{CC} = 5V	2 2.4			V V
V _{THYS}	Transmitter input hysteresis			0.5		V
I _{IL}	Input leakage current	T-IN, FORCEON, $\overline{\text{FORCEOFF}}$		± 0.01	± 1.0	µA
I _{OL}	Output leakage current	Receiver disabled		± 0.05	± 10	µA
V _{OL}	Output voltage low	I _{OUT} = 1.6mA			0.4	V
V _{OH}	Output voltage high	I _{OUT} = -1mA	V _{CC} -0.6	V _{CC} -0.1		V

Table 9. Auto-powerdown electrical characteristics

(C1 - C4 = 0.1 μ F, V_{CC} = 3V to 5.5V, T_A = -40 to 85°C, unless otherwise specified.
Typical values are referred to T_A = 25°C, FORCEON = GND, FORCEOFF = V_{CC})

Symbol	Parameter	Test Conditions	Min.	Typ.	Max.	Unit
V_{RITE}	Receiver input threshold to $\overline{INVALID}$ output voltage HIGH (Figure 3.)	Positive threshold			2.7	V
		Negative threshold	2.7			V
V_{RITD}	Receiver input threshold to $\overline{INVALID}$ output voltage LOW (Figure 3.)		-0.3		0.3	V
V_{IOL}	$\overline{INVALID}$ output voltage LOW	$I_{OUT} = 1.6\text{mA}$			0.4	V
V_{IOH}	$\overline{INVALID}$ output voltage HIGH	$I_{OUT} = -1\text{mA}$	$V_{CC}-0.6$			V
t_{WU}	Receiver or transmitter edge transmitter enabled (Figure 3.)			100		ms
t_{INVH}	Receiver positive or negative threshold to $\overline{INVALID}$ HIGH (Figure 3.)			0.2		ms
t_{INVL}	Receiver positive or negative threshold to $\overline{INVALID}$ LOW (Figure 3.)			30		ms

Table 10. Transmitter electrical characteristics

(C1 - C4 = 0.1 μ F, V_{CC} = 3V to 5.5V, T_A = -40 to 85°C, unless otherwise specified.
Typical values are referred to T_A = 25°C)

Symbol	Parameter	Test Conditions	Min.	Typ.	Max.	Unit
V_{TOUT}	Output voltage swing	All Transmitter outputs are loaded with 3K Ω to GND	± 5	± 5.4		V
R_{OUT}	Output resistance	$V_{CC} = V_+ = V_- = 0\text{V}$, $V_{OUT} = \pm 2\text{V}$	300	10M		Ω
I_{SC}	Output short circuit current	$V_{CC} = 3.3\text{V}$		± 40	± 60	mA
I_L	Output leakage current	$V_{CC} = 0$ to 5.5V, transmitter output= $\pm 12\text{V}$, transmitter disabled			± 25	μA
V_{OT}	Transmitter output voltage	T1IN = T2IN = GND, T3IN = V_{CC} T3OUT loaded with 3K Ω to GND T1OUT and T2OUT loaded with 2.5mA each	± 5			V

Table 11. Receiver electrical characteristics

(C1 - C4 = 0.1 μ F, V_{CC} = 3V to 5.5V, T_A = -40 to 85°C, unless otherwise specified.
Typical values are referred to T_A = 25°C)

Symbol	Parameter	Test Conditions	Min.	Typ.	Max.	Unit
V _{RIN}	Receiver input voltage operating range		-25		25	V
V _{RIL}	RS-232 Input threshold low	T _A = 25°C, V _{CC} = 3.3V T _A = 25°C, V _{CC} = 5.0V	0.6 0.8	1.1 1.4		V
V _{RIH}	RS-232 Input threshold high	T _A = 25°C, V _{CC} = 3.3V T _A = 25°C, V _{CC} = 5.0V		1.6 1.9	2.4 2.4	V
V _{RIHYS}	Input hysteresis			0.5		V
R _{RIN}	Input resistance	T _A = 25°C	3	5	7	K Ω

Table 12. Timing characteristics

(C1 - C4 = 0.1 μ F, V_{CC} = 3V to 5.5V, T_A = -40 to 85°C, unless otherwise specified.
Typical values are referred to T_A = 25°C)

Symbol	Parameter	Test Conditions	Min.	Typ.	Max.	Unit
D _R	Maximum data rate	R _L = 3K Ω , C _L = 1000pF one transmitter switching	250	400		Kbps
t _{PHL} t _{PLH}	Receiver propagation delay	R _{IN} to R _{OUT} , C _L = 150pF		0.15		μ s
t _{T_SKEW}	Transmitter skew			150		ns
t _{R_SKEW}	Receiver skew			70		ns
S _{RT}	Transition slew rate	T _A = 25°C R _L = 3K to 7K Ω , V _{CC} = 3.3V measured from +3V to -3V or -3V to +3V C _L = 150pF to 1000pF C _L = 150pF to 2500pF	6 4		30 30	V/ μ s V/ μ s

5 Application circuits

Figure 2. Application circuits

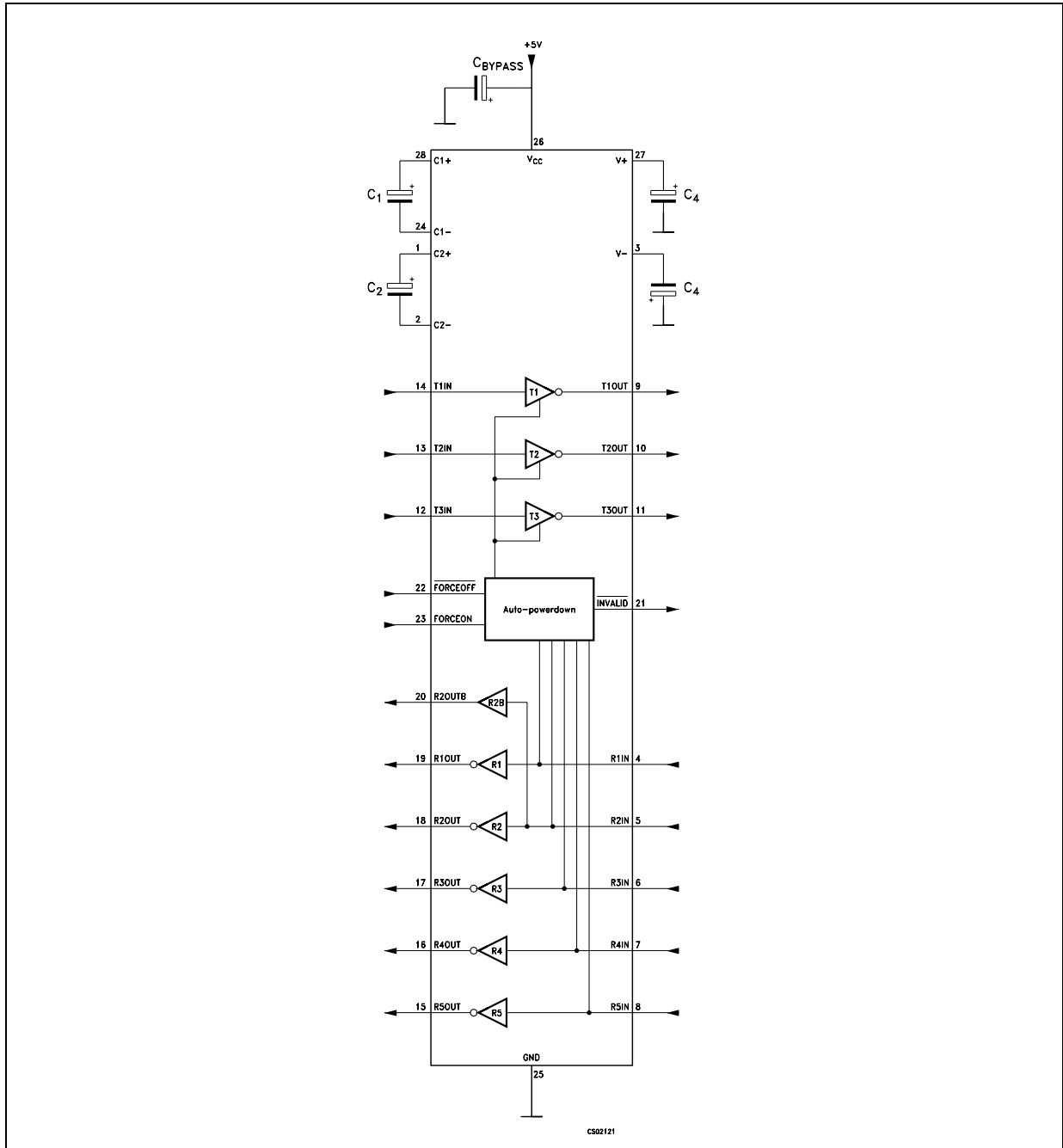

Table 13. Required minimum capacitance value (μf)

V _{CC} (V)	C ₁	C ₂ , C ₃ , C ₄ , C _{BYPASS}
3 to 3.6	0.1	0.1
4.5 to 5.5	0.047	0.33

6 Timing diagrams

Figure 3. Autopowerdown input levels

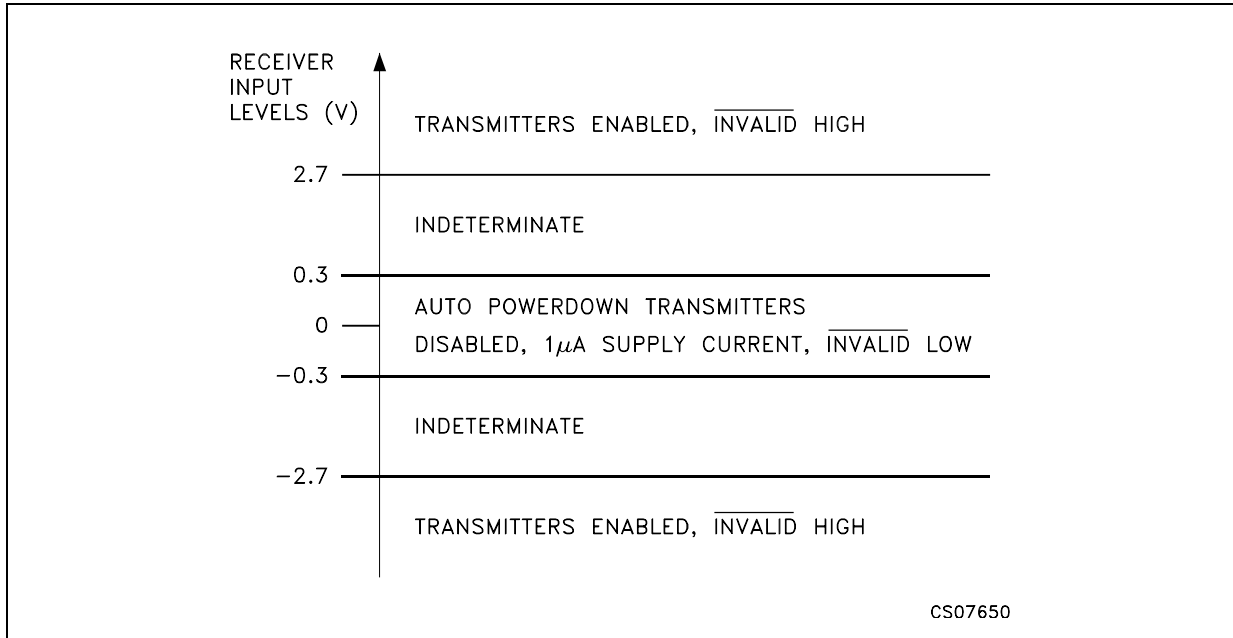
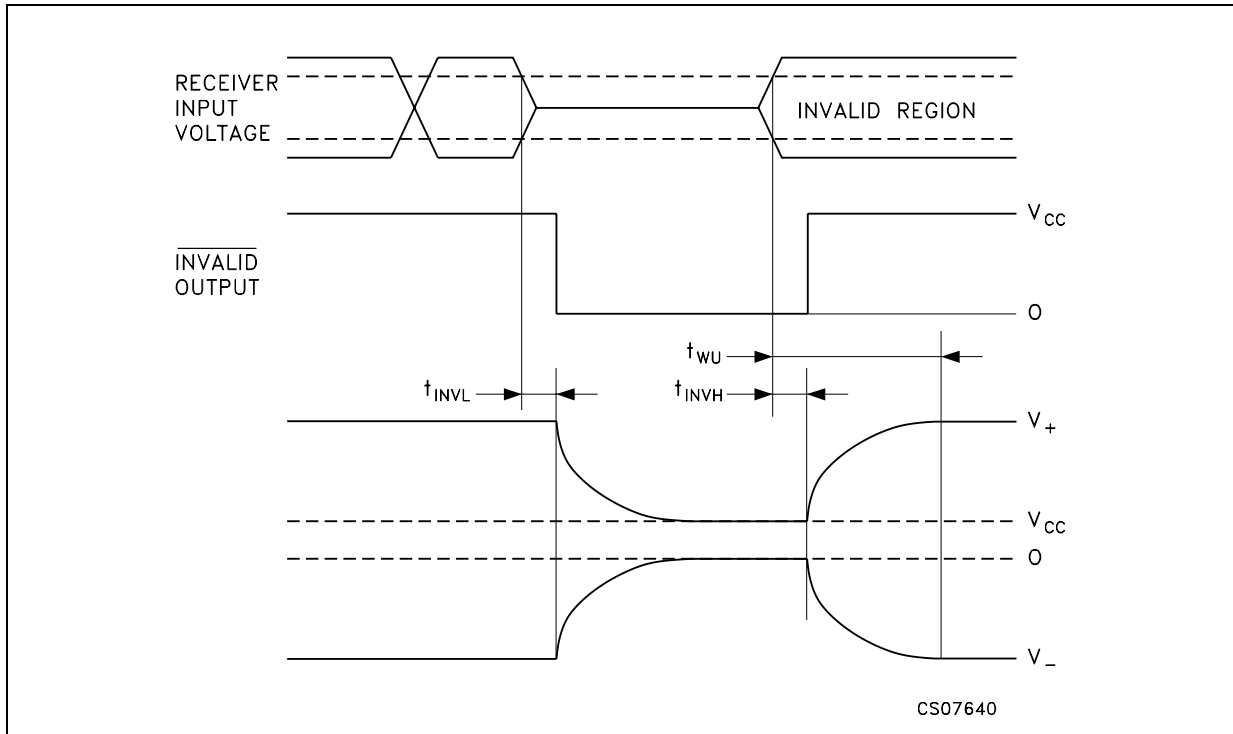

Figure 4. Autopowerdown input timing



7 Package mechanical data

In order to meet environmental requirements, ST offers these devices in ECOPACK® packages. These packages have a Lead-free second level interconnect. The category of second level interconnect is marked on the package and on the inner box label, in compliance with JEDEC Standard JESD97. The maximum ratings related to soldering conditions are also marked on the inner box label. ECOPACK is an ST trademark. ECOPACK specifications are available at: www.st.com

SO-28 MECHANICAL DATA

DIM.	mm.			inch		
	MIN.	TYP	MAX.	MIN.	TYP.	MAX.
A			2.65			0.104
a1	0.1		0.3	0.004		0.012
b	0.35		0.49	0.014		0.019
b1	0.23		0.32	0.009		0.012
C		0.5			0.020	
c1	45° (typ.)					
D	17.70		18.10	0.697		0.713
E	10.00		10.65	0.393		0.419
e		1.27			0.050	
e3		16.51			0.650	
F	7.40		7.60	0.291		0.300
L	0.50		1.27	0.020		0.050
S	8° (max.)					

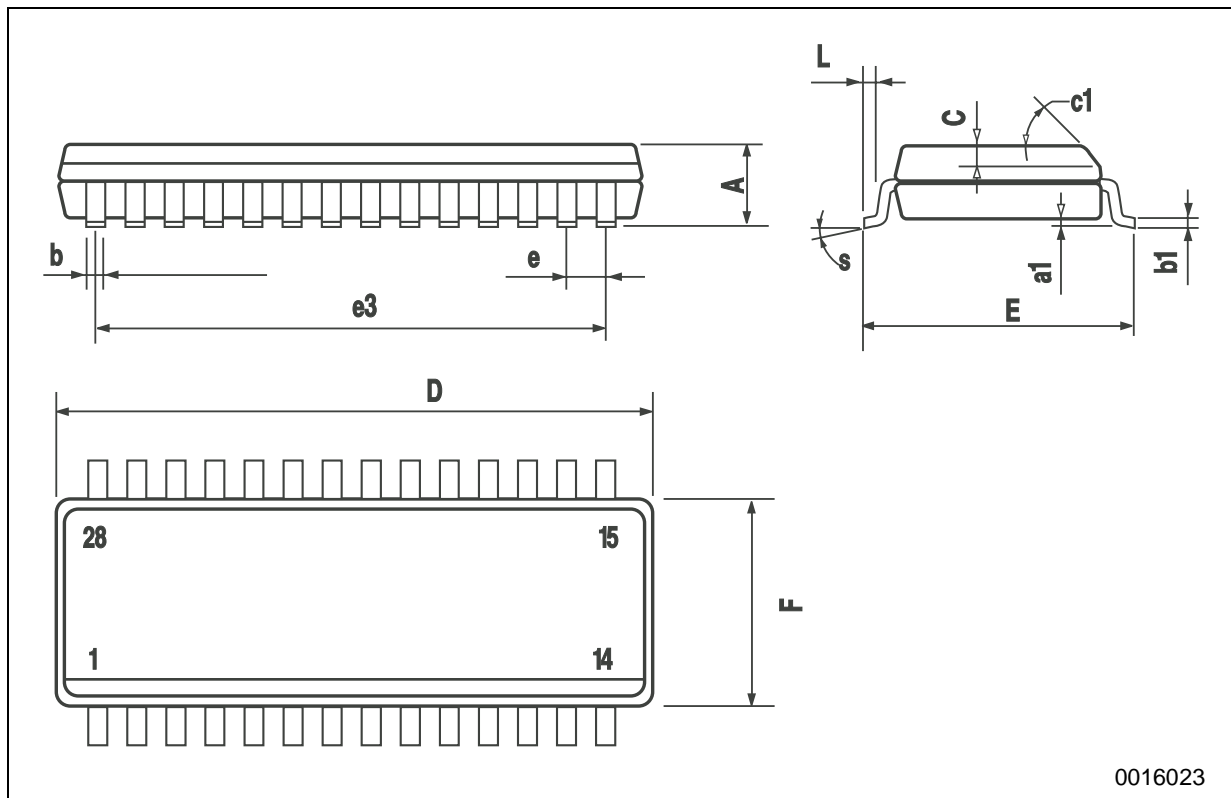

0016023

SSOP28 MECHANICAL DATA

DIM.	mm.			inch		
	MIN.	TYP	MAX.	MIN.	TYP.	MAX.
A			2			0.079
A1	0.050			0.002		
A2	1.65	1.75	1.85	0.065	0.069	0.073
b	0.22		0.38	0.009		0.015
c	0.09		0.25	0.004		0.010
D	9.9	10.2	10.5	0.390	0.402	0.413
E	7.4	7.8	8.2	0.291	0.307	0.323
E1	5	5.3	5.6	0.197	0.209	0.220
e		0.65 BSC			0.0256 BSC	
K	0°		10°	0°		10°
L	0.55	0.75	0.95	0.022	0.030	0.037

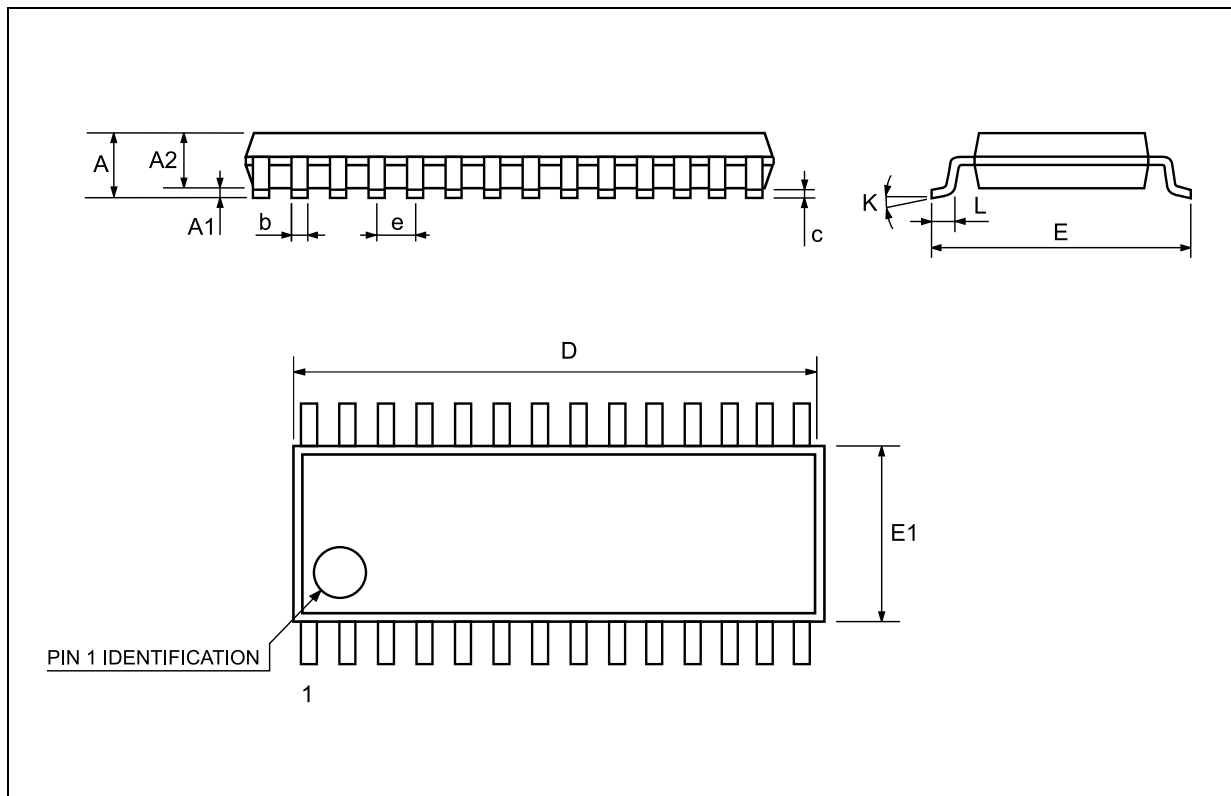

TSSOP28 MECHANICAL DATA

DIM.	mm.			inch		
	MIN.	TYP	MAX.	MIN.	TYP.	MAX.
A			1.2			0.047
A1	0.05		0.15	0.002	0.004	0.006
A2	0.8	1	1.05	0.031	0.039	0.041
b	0.19		0.30	0.007		0.012
c	0.09		0.20	0.004		0.0079
D	9.6	9.7	9.8	0.378	0.382	0.386
E	6.2	6.4	6.6	0.244	0.252	0.260
E1	4.3	4.4	4.48	0.169	0.173	0.176
e		0.65 BSC			0.0256 BSC	
K	0°		8°	0°		8°
L	0.45	0.60	0.75	0.018	0.024	0.030

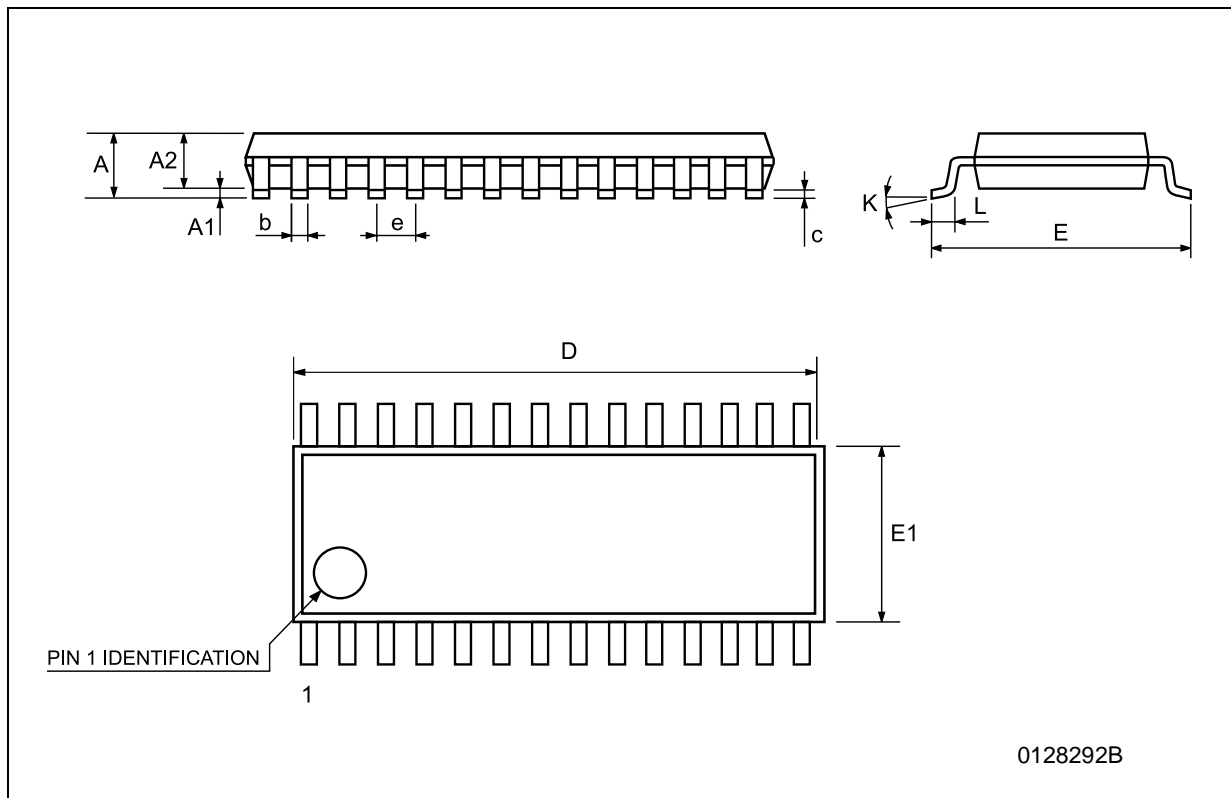

Flip-Chip28 MECHANICAL DATA

DIM.	mm.			mils		
	MIN.	TYP	MAX.	MIN.	TYP.	MAX.
A	0.83		0.95	32.7		37.4
A1		0.24			9.4	
A2		0.65			25.6	
b	0.25	0.30	0.35	9.8	11.8	13.8
D	3.97		4.17	156.3		164.2
D1		2.5			98.4	
E	2.47		2.67	97.2		105.1
E1		2			78.7	
e	0.45		0.55	17.7		21.7
f	0.23		0.34	9.1		13.4
f1	0.80		0.91	31.5		31.8

BOTTOM VIEW (BUMPS SIDE)

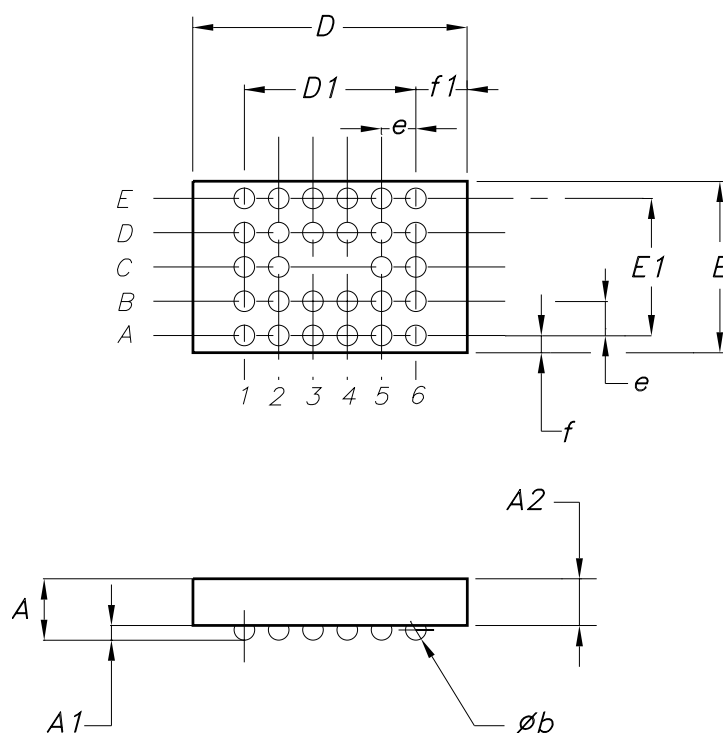

7385199/C

Tape & Reel SO-28 MECHANICAL DATA

DIM.	mm.			inch		
	MIN.	TYP	MAX.	MIN.	TYP.	MAX.
A			330			12.992
C	12.8		13.2	0.504		0.519
D	20.2			0.795		
N	60			2.362		
T			30.4			1.197
Ao	10.8		11.0	0.425		0.433
Bo	18.2		18.4	0.716		0.724
Ko	2.9		3.1	0.114		0.122
Po	3.9		4.1	0.153		0.161
P	11.9		12.1	0.468		0.476

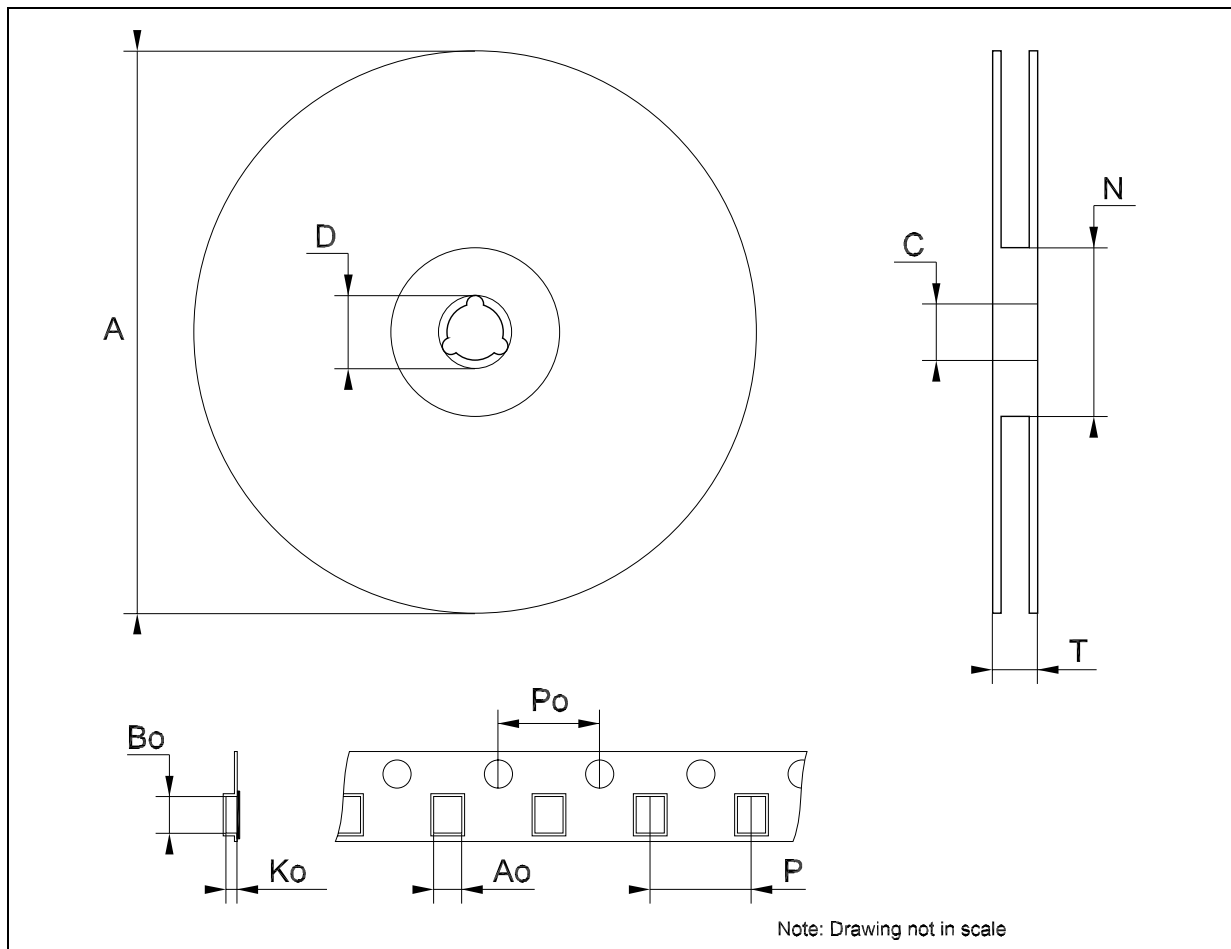

Tape & Reel SSOP28 MECHANICAL DATA

DIM.	mm.			inch		
	MIN.	TYP	MAX.	MIN.	TYP.	MAX.
A			330			12.992
C	12.8		13.2	0.504		0.519
D	20.2			0.795		
N	60			2.362		
T			22.4			0.882
Ao	8.4		8.6	0.331		0.339
Bo	10.7		10.9	0.421		0.429
Ko	2.9		3.1	0.114		0.122
Po	3.9		4.1	0.153		0.161
P	11.9		12.1	0.468		0.476

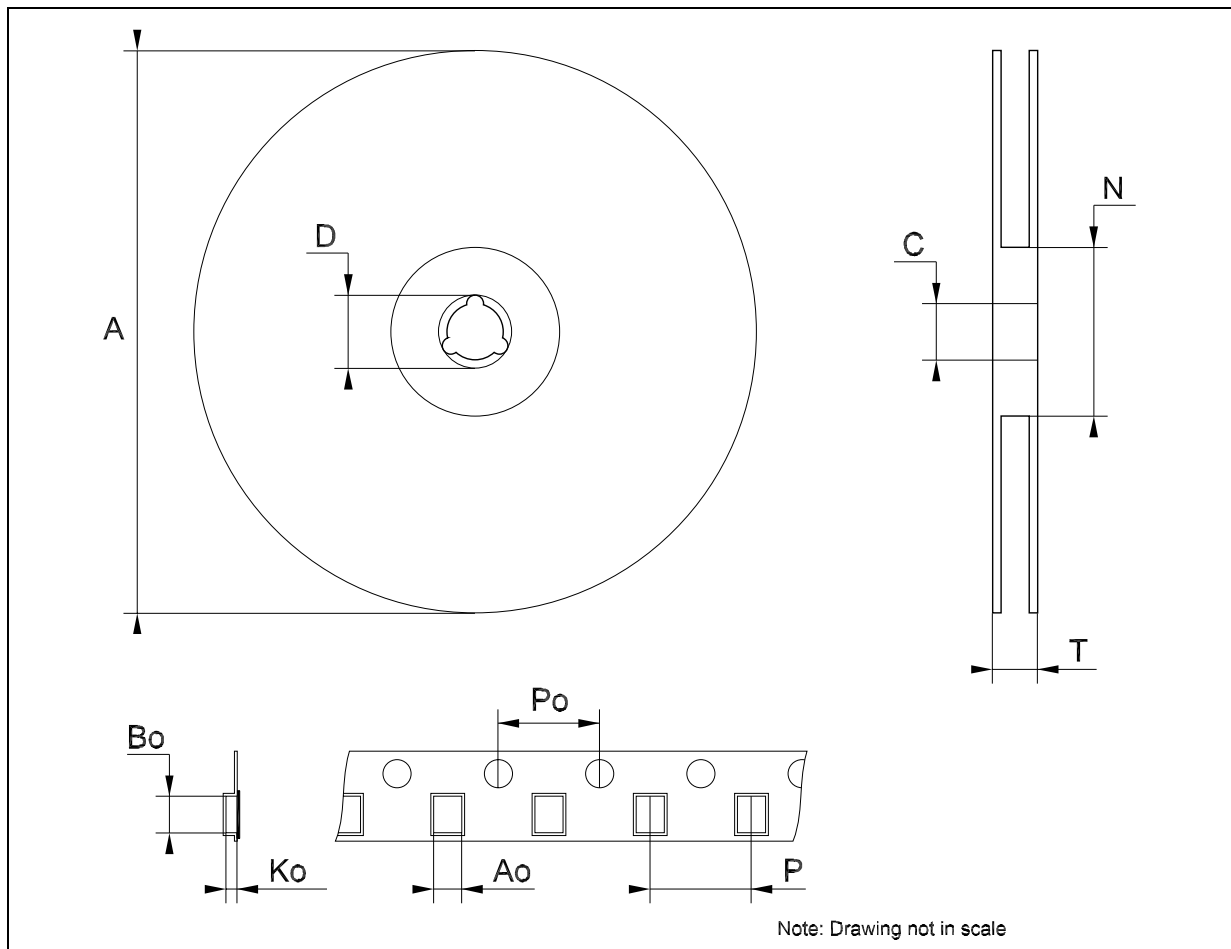

Tape & Reel TSSOP28 MECHANICAL DATA

DIM.	mm.			inch		
	MIN.	TYP	MAX.	MIN.	TYP.	MAX.
A			330			12.992
C	12.8		13.2	0.504		0.519
D	20.2			0.795		
N	60			2.362		
T			22.4			0.882
Ao	6.8		7	0.268		0.276
Bo	10.1		10.3	0.398		0.406
Ko	1.7		1.9	0.067		0.075
Po	3.9		4.1	0.153		0.161
P	11.9		12.1	0.468		0.476

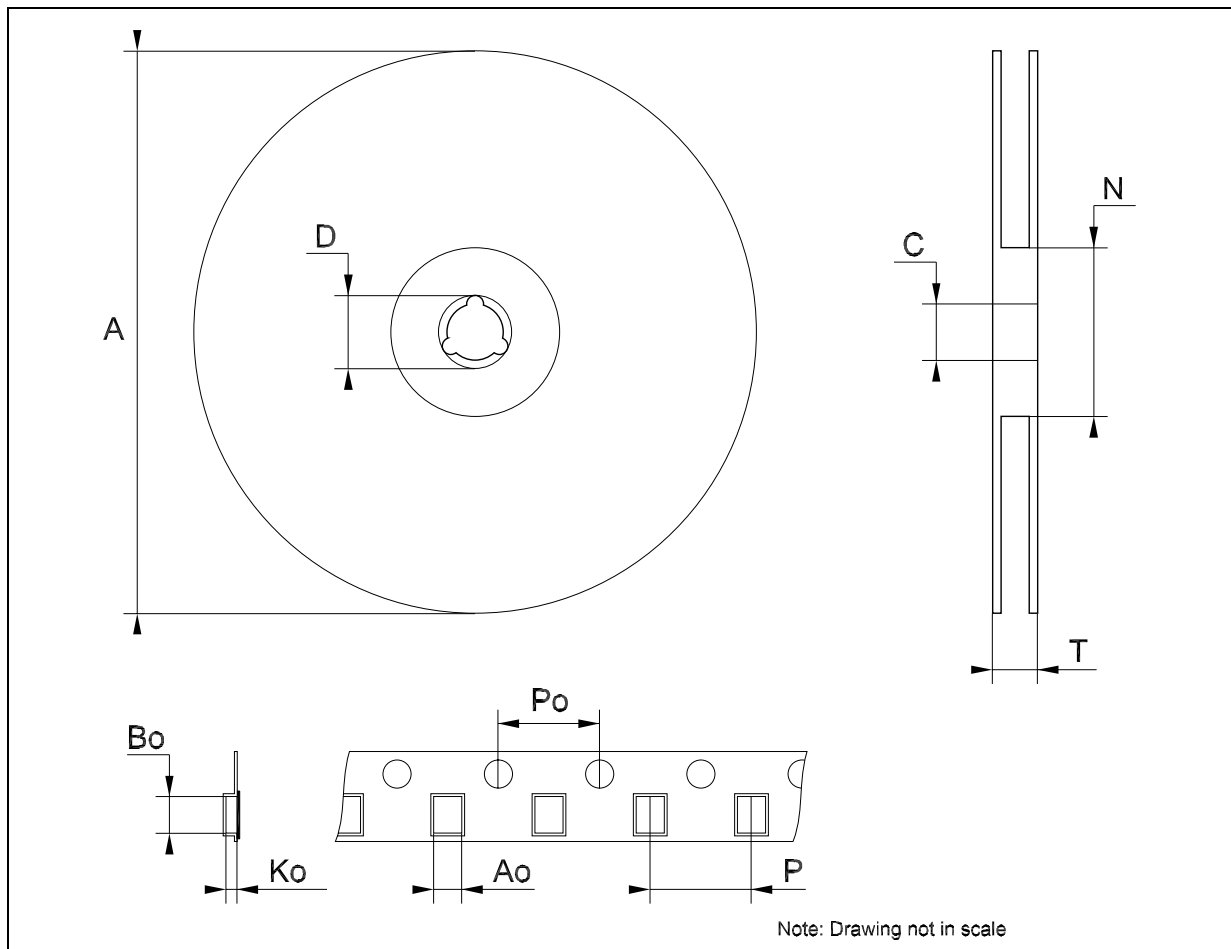

Tape & Reel Flip-Chip28 MECHANICAL DATA

DIM.	mm.			inch		
	MIN.	TYP	MAX.	MIN.	TYP.	MAX.
A			330			12.992
C	12.8		13.2	0.504		0.519
D	20.2			0.795		
N	60			2.362		
T			18.4			0.882
Ao	2.6		2.8	0.102		0.110
Bo	4.1		4.3	0.161		0.169
Ko	1.1		1.3	0.043		0.051
Po	3.9		4.1	0.153		0.161
P	3.9		4.1	0.153		0.161

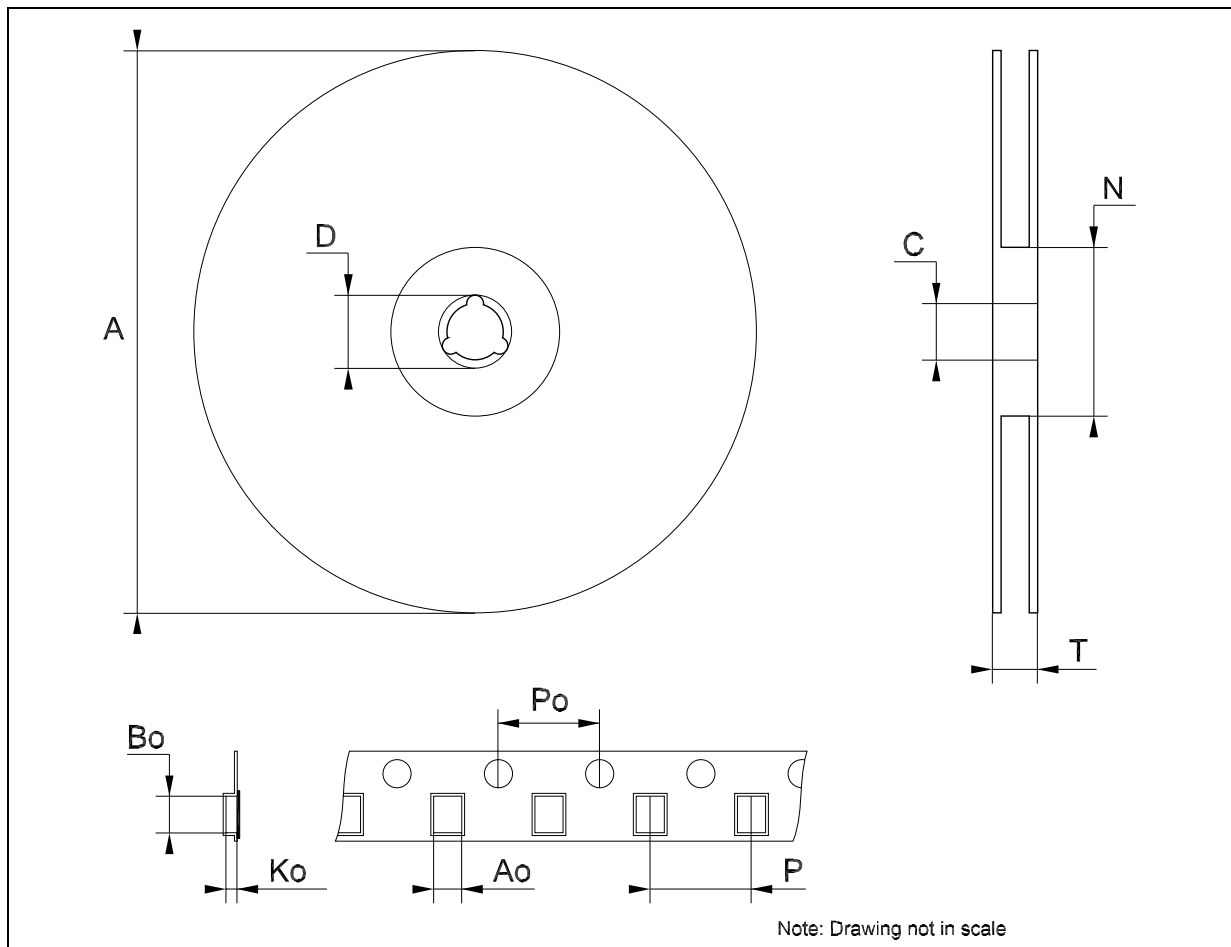

8 Order code

Table 14. Order code

Part number	Temperature range	Package	Comments
ST3243ECDR	0 to 70°C	SO-28 (Tape & Reel)	1000 parts per reel
ST3243EBDR	-40 to 85°C	SO-28 (Tape & Reel)	1000 parts per reel
ST3243ECPR	0 to 70°C	SSOP-28 (Tape & Reel)	1350 parts per reel
ST3243EBPR	-40 to 85°C	SSOP-28 (Tape & Reel)	1350 parts per reel
ST3243ECTR	0 to 70°C	TSSOP28 (Tape & Reel)	2500 parts per reel
ST3243EBTR	-40 to 85°C	TSSOP28 (Tape & Reel)	2500 parts per reel
ST3243ECJ	0 to 70°C	Flip-Chip28	coming soon
ST3243EBJ	-40 to 85°C	Flip-Chip28	coming soon

9 Revision history

Table 15. Revision history

Date	Revision	Changes
21-Jun-2004	6	Page 6 - IL (output leakage current) mA ==> μ A
31-Mar-2006	7	Order codes has been updated and new template.

Please Read Carefully:

Information in this document is provided solely in connection with ST products. STMicroelectronics NV and its subsidiaries ("ST") reserve the right to make changes, corrections, modifications or improvements, to this document, and the products and services described herein at any time, without notice.

All ST products are sold pursuant to ST's terms and conditions of sale.

Purchasers are solely responsible for the choice, selection and use of the ST products and services described herein, and ST assumes no liability whatsoever relating to the choice, selection or use of the ST products and services described herein.

No license, express or implied, by estoppel or otherwise, to any intellectual property rights is granted under this document. If any part of this document refers to any third party products or services it shall not be deemed a license grant by ST for the use of such third party products or services, or any intellectual property contained therein or considered as a warranty covering the use in any manner whatsoever of such third party products or services or any intellectual property contained therein.

UNLESS OTHERWISE SET FORTH IN ST'S TERMS AND CONDITIONS OF SALE ST DISCLAIMS ANY EXPRESS OR IMPLIED WARRANTY WITH RESPECT TO THE USE AND/OR SALE OF ST PRODUCTS INCLUDING WITHOUT LIMITATION IMPLIED WARRANTIES OF MERCHANTABILITY, FITNESS FOR A PARTICULAR PURPOSE (AND THEIR EQUIVALENTS UNDER THE LAWS OF ANY JURISDICTION), OR INFRINGEMENT OF ANY PATENT, COPYRIGHT OR OTHER INTELLECTUAL PROPERTY RIGHT.

UNLESS EXPRESSLY APPROVED IN WRITING BY AN AUTHORIZED REPRESENTATIVE OF ST, ST PRODUCTS ARE NOT DESIGNED, AUTHORIZED OR WARRANTED FOR USE IN MILITARY, AIR CRAFT, SPACE, LIFE SAVING, OR LIFE SUSTAINING APPLICATIONS, NOR IN PRODUCTS OR SYSTEMS, WHERE FAILURE OR MALFUNCTION MAY RESULT IN PERSONAL INJURY, DEATH, OR SEVERE PROPERTY OR ENVIRONMENTAL DAMAGE.

Resale of ST products with provisions different from the statements and/or technical features set forth in this document shall immediately void any warranty granted by ST for the ST product or service described herein and shall not create or extend in any manner whatsoever, any liability of ST.

ST and the ST logo are trademarks or registered trademarks of ST in various countries.

Information in this document supersedes and replaces all information previously supplied.

The ST logo is a registered trademark of STMicroelectronics. All other names are the property of their respective owners.

© 2006 STMicroelectronics - All rights reserved

STMicroelectronics group of companies

Australia - Belgium - Brazil - Canada - China - Czech Republic - Finland - France - Germany - Hong Kong - India - Israel - Italy - Japan - Malaysia - Malta - Morocco - Singapore - Spain - Sweden - Switzerland - United Kingdom - United States of America

www.st.com