

Back to back SCR module

Table 1. Main features

Symbol	Value	Unit
$I_{T(RMS)}$	55 and 70	A
V_{DRM}/V_{RRM}	800 and 1200	V
I_{GT}	50	mA

Description

Packaged in ISOTOP modules, the MSS40 / MSS50 Series is based on two back-to-back SCR configurations, providing high noise immunity. They are suitable for high power applications such as solid state relays, heating control systems, welding equipment, motor control circuits...

The compactness of the ISOTOP package allows high power density and optimized power bus connections. Thanks to their internal ceramic pad, they provide high voltage insulation (2500 V_{RMS}), complying with UL standards (File ref: E81734).

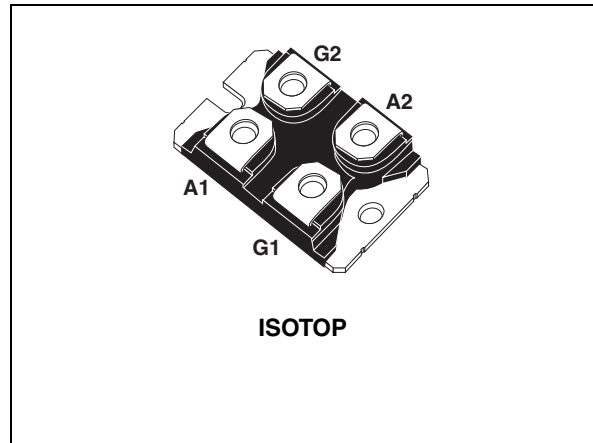
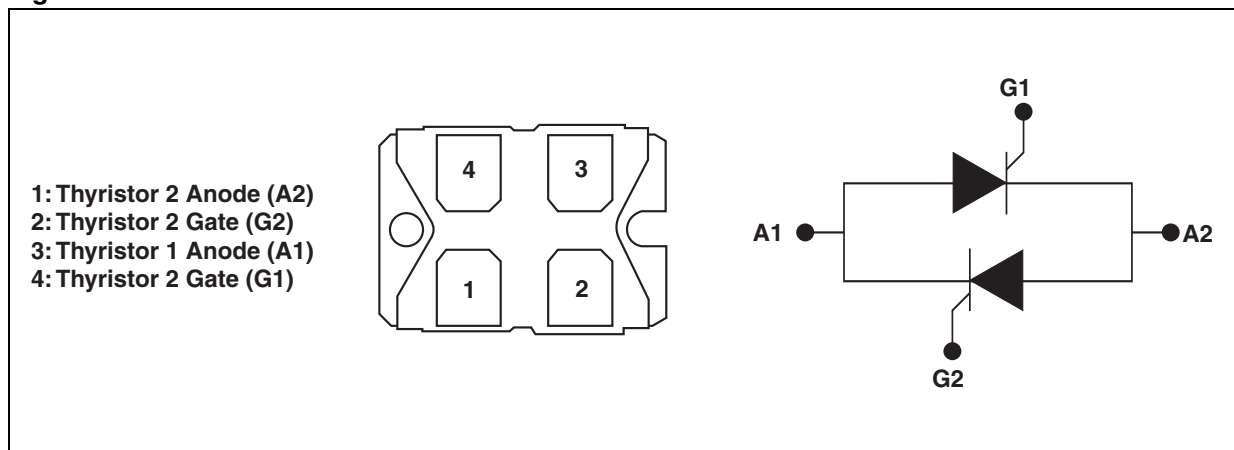

Table 2. Order codes

Part numbers	Marking
MSS40-1200	MSS40-1200
MSS50-800	MSS50-800
MSS50-1200	MSS50-1200

Figure 1. Pin connections



1 Characteristics

Table 3. Absolute ratings (limiting values)

Symbol	Parameter			Value		Unit
				MSS40	MSS50	
V_{DRM}/V_{RRM}	Repetitive peak off-state voltage			1200	800 1200	V
$I_{T(RMS)}$	RMS on-state current		$T_c = 80^\circ\text{C}$	55		A
			$T_c = 85^\circ\text{C}$		70	
I_{TSM}	Non repetitive surge peak on-state current	$t_p = 16.7\text{ ms}$ $t_p = 20\text{ ms}$	$T_j = 25^\circ\text{C}$	420	630	A
				400	600	
I^2t	I^2t Value for fusing	$t_p = 10\text{ ms}$	$T_j = 25^\circ\text{C}$	800	1800	A^2s
di/dt	Critical rate of rise of on-state current $I_G = 2 \times I_{GT}$, $t_r \leq 100\text{ ns}$	$F = 120\text{ Hz}$	$T_j = 125^\circ\text{C}$	50		$A/\mu s$
I_{GM}	Peak gate current	$t_p = 20\ \mu s$	$T_j = 125^\circ\text{C}$	4		A
$P_{G(AV)}$	Average gate power dissipation		$T_j = 125^\circ\text{C}$	1		W
T_{stg} T_j	Storage junction temperature range Operating junction temperature range			- 40 to + 150 - 40 to + 125		$^\circ\text{C}$
V_{RGM}	Maximum peak reverse gate voltage			5		V

Table 4. Electrical characteristics ($T_j = 25^\circ\text{C}$, unless otherwise specified)

Symbol	Test Conditions			Value		Unit
				MSS40	MSS50	
I_{GT}	$V_D = 12\text{ V}$ $R_L = 33\ \Omega$		MIN.	5		mA
			MAX.	50		
V_{GT}			MAX.	1.3		V
V_{GD}	$V_D = V_{DRM}$ $R_L = 3.3\text{ k}\Omega$	$T_j = 125^\circ\text{C}$	MIN.	0.2		V
I_H	$I_T = 500\text{ mA}$ Gate open		MAX.	80		mA
I_L	$I_G = 1.2 I_{GT}$		MAX.	120		mA
dV/dt	$V_D = 67\% V_{DRM}$ Gate open	$T_j = 125^\circ\text{C}$	MIN.	1000		$V/\mu s$
V_{TM}	$I_{TM} = 80\text{ A}$ $t_p = 380\ \mu s$	$T_j = 25^\circ\text{C}$	MAX.	1.7		V
	$I_{TM} = 100\text{ A}$ $t_p = 380\ \mu s$				1.7	
V_{t0}	Threshold voltage		$T_j = 125^\circ\text{C}$	MAX.	0.85	
R_d	Dynamic resistance		$T_j = 125^\circ\text{C}$	MAX.	11	7
I_{DRM} I_{RRM}	$V_{DRM} = V_{RRM}$		$T_j = 25^\circ\text{C}$	MAX.	20	
			$T_j = 125^\circ\text{C}$		10	

Table 5. Thermal reistances

Symbol	Parameter		Value	Unit	
$R_{th(j-c)}$	Junction to case (AC)		MSS40	0.6	$^\circ\text{C/W}$
			MSS50	0.45	

Figure 2. Maximum average power dissipation versus average on-state current

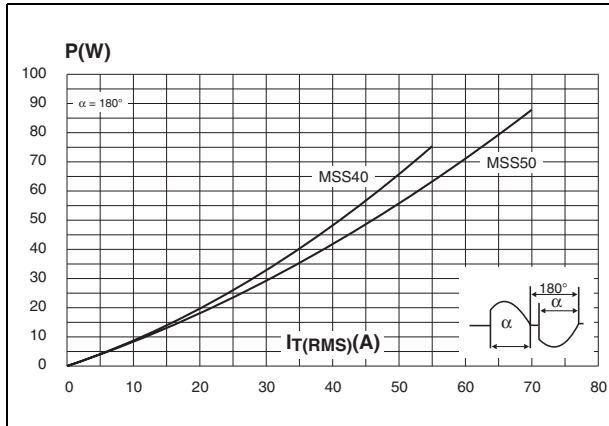

Figure 3. Average and DC on-state current versus case temperature

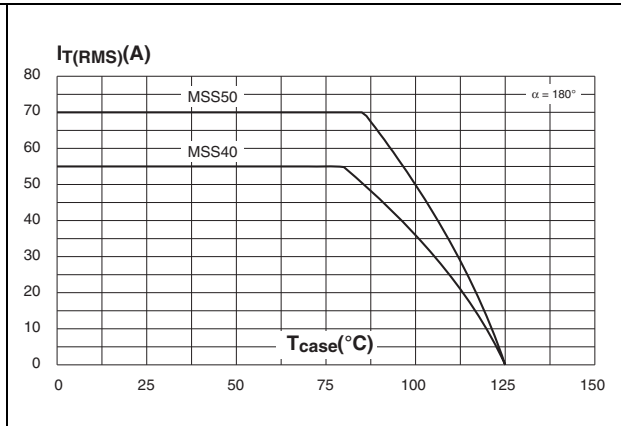

Figure 4. Relative variation of thermal impedance versus pulse duration

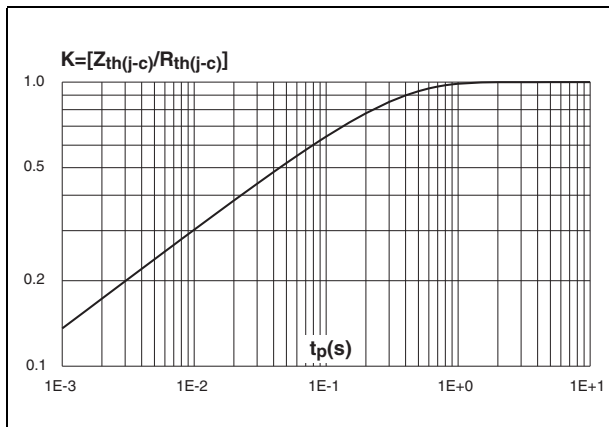

Figure 5. Relative variation of gate trigger current and holding current versus junction temperature

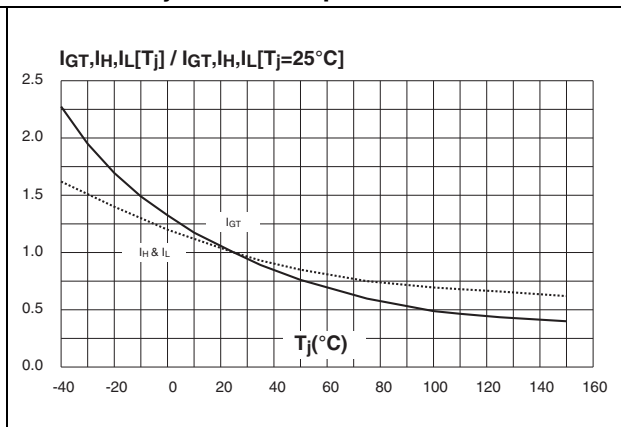

Figure 6. Surge peak on-state current versus number of cycles

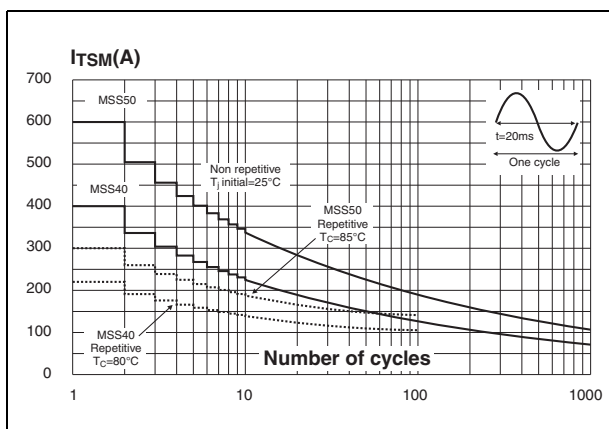

Figure 7. Non-repetitive surge peak on-state current for a sinusoidal pulse with width $t_p < 10$ ms, and corresponding values of I^2t

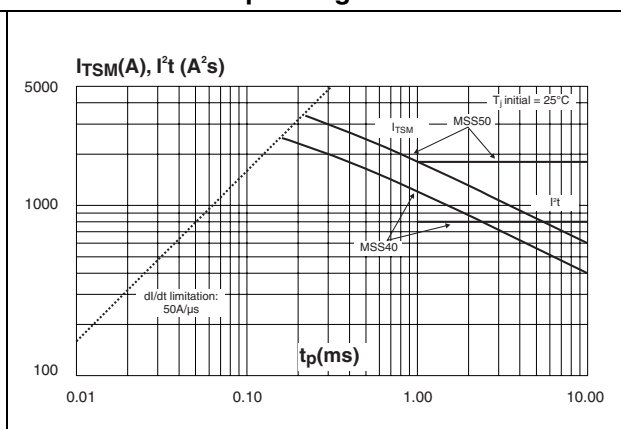

Figure 8. On-state characteristics (maximum values) (MSS40)

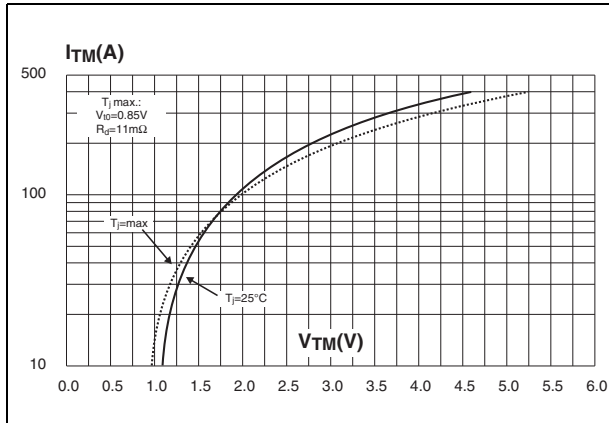
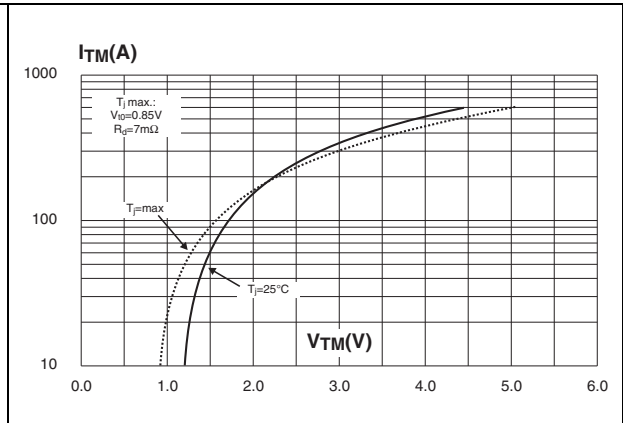
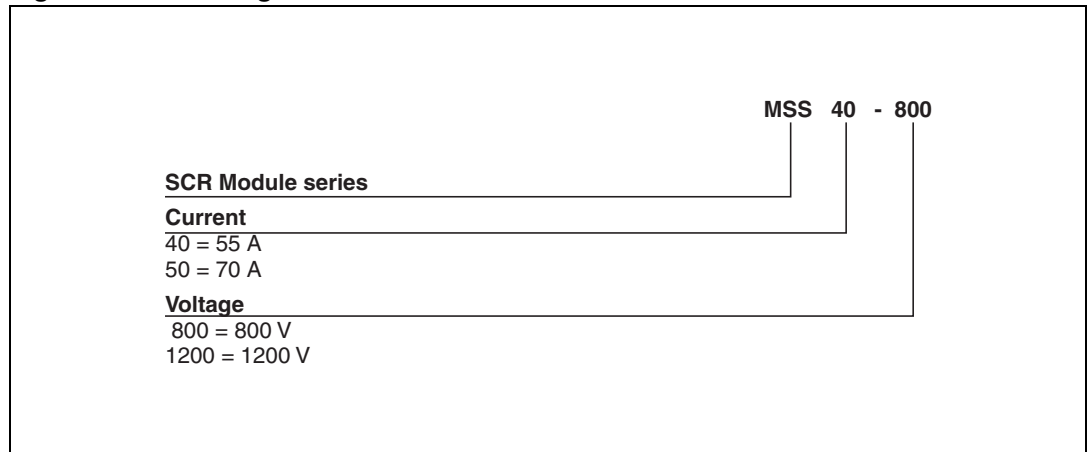

Figure 9. On-state characteristics (maximum values) (MSS50)



2 Ordering information scheme

Figure 10. Ordering information scheme



3 Package information

- Epoxy meets UL94, V0
- Cooling method: by conduction (C)
- Recommended torque value: 0.9 Nm (max. 1.2 Nm) for the 6 x M4 screws (2 x M4 screws recommended for mounting the package on the heatsink and the 4 provided screws).
- The screws supplied with the package are adapted for mounting on a board (or other types of terminals) with a thickness of 0.6 mm min. and 2.2 mm max.

Table 6. ISOTOP dimensions

Ref.	Dimensions			
	Millimeters		Inches	
	Min.	Max.	Min.	Max.
A	11.80	12.20	0.465	0.480
A1	8.90	9.10	0.350	0.358
B	7.8	8.20	0.307	0.323
C	0.75	0.85	0.030	0.033
C2	1.95	2.05	0.077	0.081
D	37.80	38.20	1.488	1.504
D1	31.50	31.70	1.240	1.248
E	25.15	25.50	0.990	1.004
E1	23.85	24.15	0.939	0.951
E2	24.80 typ.		0.976 typ.	
G	14.90	15.10	0.587	0.594
G1	12.60	12.80	0.496	0.504
G2	3.50	4.30	0.138	0.169
F	4.10	4.30	0.161	0.169
F1	4.60	5.00	0.181	0.197
P	4.00	4.30	0.157	0.69
P1	4.00	4.40	0.157	0.173
S	30.10	30.30	1.185	1.193

In order to meet environmental requirements, ST offers these devices in ECOPACK® packages. These packages have a lead-free second level interconnect. The category of second level interconnect is marked on the package and on the inner box label, in compliance with JEDEC Standard JESD97. The maximum ratings related to soldering conditions are also marked on the inner box label. ECOPACK is an ST trademark. ECOPACK specifications are available at: www.st.com.

4 Ordering information

Table 7. Ordering information

Part number	Marking	Package	Weight	Base qty	Delivery mode
MSS40-1200	MSS40-1200	ISOTOP	27 g (without screws)	10 (with screws)	Tube
MSS50-800	MSS50-800				
MSS50-1200	MSS50-1200				

5 Revision history

Table 8. Revision history

Date	Revision	Changes
Sep-2000	3	Last release.
11-Jul-2007	4	Reformatted to current standards. Removed MSS40-800 product.

Please Read Carefully:

Information in this document is provided solely in connection with ST products. STMicroelectronics NV and its subsidiaries ("ST") reserve the right to make changes, corrections, modifications or improvements, to this document, and the products and services described herein at any time, without notice.

All ST products are sold pursuant to ST's terms and conditions of sale.

Purchasers are solely responsible for the choice, selection and use of the ST products and services described herein, and ST assumes no liability whatsoever relating to the choice, selection or use of the ST products and services described herein.

No license, express or implied, by estoppel or otherwise, to any intellectual property rights is granted under this document. If any part of this document refers to any third party products or services it shall not be deemed a license grant by ST for the use of such third party products or services, or any intellectual property contained therein or considered as a warranty covering the use in any manner whatsoever of such third party products or services or any intellectual property contained therein.

UNLESS OTHERWISE SET FORTH IN ST'S TERMS AND CONDITIONS OF SALE ST DISCLAIMS ANY EXPRESS OR IMPLIED WARRANTY WITH RESPECT TO THE USE AND/OR SALE OF ST PRODUCTS INCLUDING WITHOUT LIMITATION IMPLIED WARRANTIES OF MERCHANTABILITY, FITNESS FOR A PARTICULAR PURPOSE (AND THEIR EQUIVALENTS UNDER THE LAWS OF ANY JURISDICTION), OR INFRINGEMENT OF ANY PATENT, COPYRIGHT OR OTHER INTELLECTUAL PROPERTY RIGHT.

UNLESS EXPRESSLY APPROVED IN WRITING BY AN AUTHORIZED ST REPRESENTATIVE, ST PRODUCTS ARE NOT RECOMMENDED, AUTHORIZED OR WARRANTED FOR USE IN MILITARY, AIR CRAFT, SPACE, LIFE SAVING, OR LIFE SUSTAINING APPLICATIONS, NOR IN PRODUCTS OR SYSTEMS WHERE FAILURE OR MALFUNCTION MAY RESULT IN PERSONAL INJURY, DEATH, OR SEVERE PROPERTY OR ENVIRONMENTAL DAMAGE. ST PRODUCTS WHICH ARE NOT SPECIFIED AS "AUTOMOTIVE GRADE" MAY ONLY BE USED IN AUTOMOTIVE APPLICATIONS AT USER'S OWN RISK.

Resale of ST products with provisions different from the statements and/or technical features set forth in this document shall immediately void any warranty granted by ST for the ST product or service described herein and shall not create or extend in any manner whatsoever, any liability of ST.

ST and the ST logo are trademarks or registered trademarks of ST in various countries.

Information in this document supersedes and replaces all information previously supplied.

The ST logo is a registered trademark of STMicroelectronics. All other names are the property of their respective owners.

© 2007 STMicroelectronics - All rights reserved

STMicroelectronics group of companies

Australia - Belgium - Brazil - Canada - China - Czech Republic - Finland - France - Germany - Hong Kong - India - Israel - Italy - Japan - Malaysia - Malta - Morocco - Singapore - Spain - Sweden - Switzerland - United Kingdom - United States of America

www.st.com