



MJE13007A

SILICON NPN SWITCHING TRANSISTOR

- STMicroelectronics PREFERRED SALESTYPE NPN TRANSISTOR
- HIGH CURRENT CAPABILITY

APPLICATIONS

- SWITCHING REGULATORS
- MOTOR CONTROL

DESCRIPTION

The MJE13007A is a silicon Multi-Epitaxial Mesa NPN power transistor mounted in Jedec TO-220 plastic package.

It is intended for use in motor control, switching regulators.

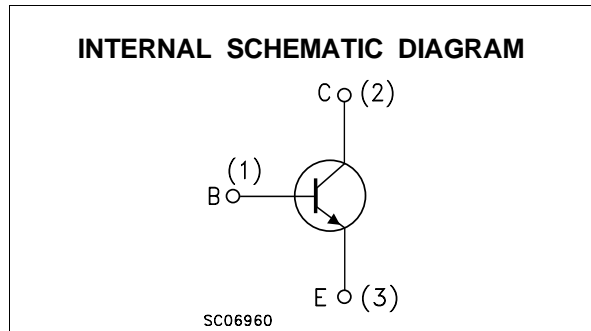
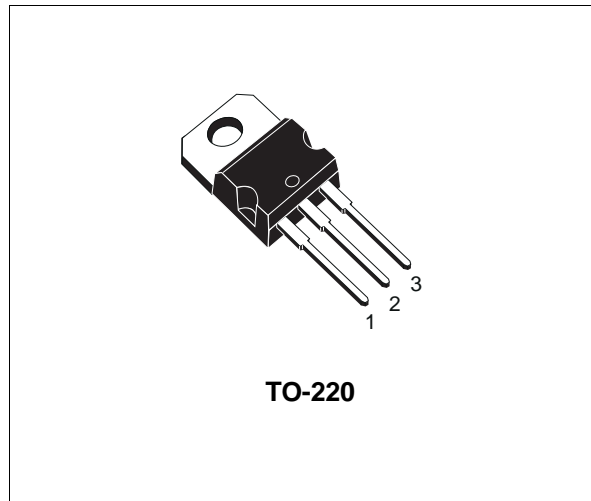

ABSOLUTE MAXIMUM RATINGS

Symbol	Parameter	Value	Unit
V_{CEV}	Collector-Emitter Voltage ($V_{BE} = -1.5V$)	850	V
V_{CEO}	Collector-Emitter Voltage ($I_B = 0$)	400	V
V_{EBO}	Emitter-Base Voltage ($I_C = 0$)	9	V
I_C	Collector Current	8	A
I_{CM}	Collector Peak Current	16	A
I_B	Base Current	4	A
I_{BM}	Base Peak Current	8	A
I_E	Emitter Current	12	A
I_{EM}	Emitter Peak Current	24	A
P_{tot}	Total Dissipation at $T_c \leq 25^\circ C$	80	W
T_{stg}	Storage Temperature	-65 to 150	$^\circ C$
T_j	Max. Operating Junction Temperature	150	$^\circ C$

MJE13007A

THERMAL DATA

R _{thj-case}	Thermal Resistance Junction-case	Max	1.56	°C/W
-----------------------	----------------------------------	-----	------	------

ELECTRICAL CHARACTERISTICS (T_{case} = 25 °C unless otherwise specified)

Symbol	Parameter	Test Conditions	Min.	Typ.	Max.	Unit
I _{CEV}	Collector Cut-off Current (V _{BE} = -1.5V)	V _{CE} = rated V _{CEV} V _{CE} = rated V _{CEV} T _c = 100 °C			1 5	mA mA
I _{EBO}	Emitter Cut-off Current (I _C = 0)	V _{EB} = 9 V			1	mA
V _{CEO(sus)*}	Collector-Emitter Sustaining Voltage (I _B = 0)	I _C = 10 mA	400			V
V _{CE(sat)*}	Collector-Emitter Saturation Voltage	I _C = 2 A I _B = 0.4 A I _C = 5 A I _B = 1 A I _C = 8 A I _B = 2 A I _C = 5 A I _B = 1 A T _c = 100 °C			1 1.5 3 2	V V V V
V _{BE(sat)*}	Base-Emitter Saturation Voltage	I _C = 2 A I _B = 0.4 A I _C = 5 A I _B = 1 A I _C = 5 A I _B = 1 A T _c = 100 °C			1.2 1.6 1.5	V V V
h _{FE*}	DC Current Gain	I _C = 2 A V _{CE} = 5 V I _C = 5 A V _{CE} = 5 V	8 6		40 30	
f _T	Transition Frequency	I _C = 0.5 A V _{CE} = 10 V f = 1 MHz	4			MHz
C _{CBO}	Output Capacitance	I _E = 0 V _{CB} = 10 V f = 0.1 MHz		110		pF

RESISTIVE LOAD

Symbol	Parameter	Test Conditions	Min.	Typ.	Max.	Unit
t _{on}	Turn-on Time	V _{CC} = 125 V I _C = 5 A			0.7	μs
t _s	Storage Time	I _{B1} = -I _{B2} = 1 A			3	μs
t _f	Fall Time	t _p = 25 μs Duty Cycle < 1%			0.7	μs

INDUCTIVE LOAD

Symbol	Parameter	Test Conditions	Min.	Typ.	Max.	Unit
t _f	Fall Time	V _{CC} = 125 V I _C = 5 A I _{B1} = 1 A t _p = 25 μs Duty Cycle < 1%			0.3	μs
t _f	Fall Time	V _{CC} = 125 V I _C = 5 A I _{B1} = 1 A t _p = 25 μs Duty Cycle < 1% T _c = 100 °C			0.6	μs

* Pulsed: Pulse duration = 300 μs, duty cycle 2 %

TO-220 MECHANICAL DATA

DIM.	mm			inch		
	MIN.	TYP.	MAX.	MIN.	TYP.	MAX.
A	4.40		4.60	0.173		0.181
C	1.23		1.32	0.048		0.052
D	2.40		2.72	0.094		0.107
E	0.49		0.70	0.019		0.027
F	0.61		0.88	0.024		0.034
F1	1.14		1.70	0.044		0.067
F2	1.14		1.70	0.044		0.067
G	4.95		5.15	0.194		0.202
G1	2.40		2.70	0.094		0.106
H2	10.00		10.40	0.394		0.409
L2		16.40			0.645	
L4	13.00		14.00	0.511		0.551
L5	2.65		2.95	0.104		0.116
L6	15.25		15.75	0.600		0.620
L7	6.20		6.60	0.244		0.260
L9	3.50		3.93	0.137		0.154
M		2.60			0.102	
DIA.	3.75		3.85	0.147		0.151

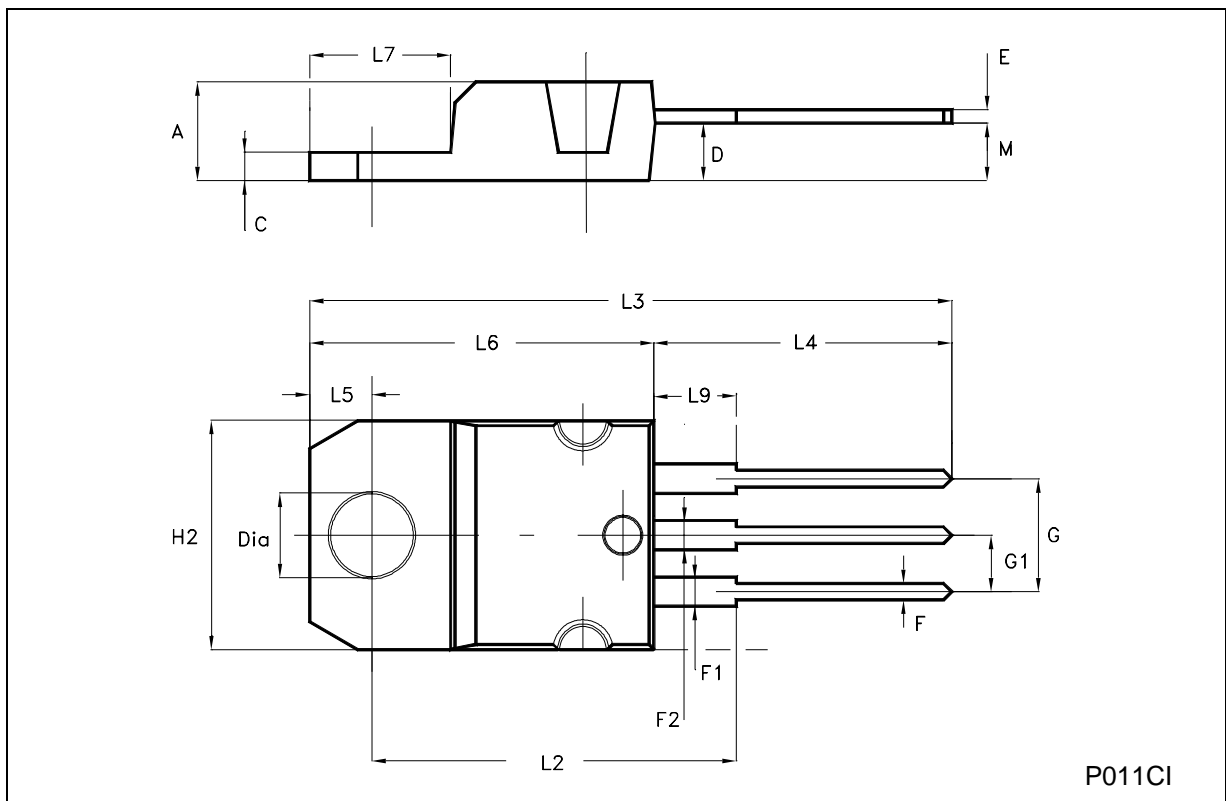

Information furnished is believed to be accurate and reliable. However, STMicroelectronics assumes no responsibility for the consequences of use of such information nor for any infringement of patents or other rights of third parties which may result from its use. No license is granted by implication or otherwise under any patent or patent rights of STMicroelectronics. Specification mentioned in this publication are subject to change without notice. This publication supersedes and replaces all information previously supplied. STMicroelectronics products are not authorized for use as critical components in life support devices or systems without express written approval of STMicroelectronics.

The ST logo is a trademark of STMicroelectronics.

All other names are the property of their respective owners.

© 2003 STMicroelectronics – All Rights reserved

STMicroelectronics GROUP OF COMPANIES

Australia - Belgium - Brazil - Canada - China - Czech Republic - Finland - France - Germany - Hong Kong - India - Israel - Italy - Japan - Malaysia - Malta - Morocco - Singapore - Spain - Sweden - Switzerland - United Kingdom - United States.

<http://www.st.com>