



STV250N55F3

N-channel 55 V, 1.5 mΩ, 250 A, PowerSO-10
STripFET™ Power MOSFET

Features

Type	V _{DSS}	R _{DS(on) max}	I _D
STV250N55F3	55 V	< 2.2 mΩ	250 A

- Conduction losses reduced
- Low profile, very low parasitic inductance

Application

- Switching applications

Description

This n-channel enhancement mode Power MOSFET is the latest refinement of STMicroelectronics unique “single feature size” strip-based process with less critical alignment steps and therefore a remarkable manufacturing reproducibility. The resulting transistor shows extremely high packing density for low on-resistance, rugged avalanche characteristics and low gate charge.

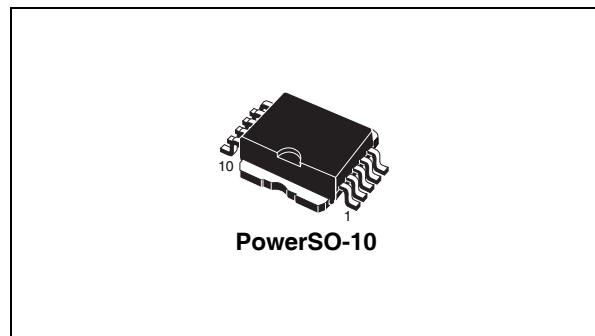

Figure 1. Internal schematic diagram and connection diagram (top view)

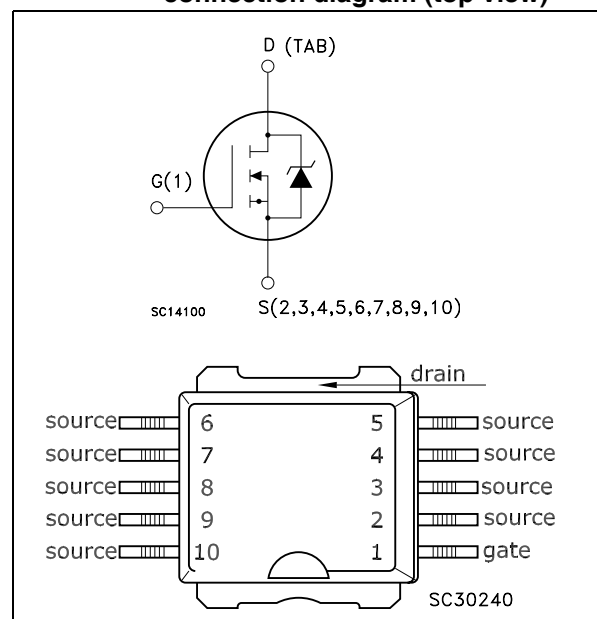

Table 1. Device summary

Order code	Marking	Package	Packaging
STV250N55F3	250N55F3	PowerSO-10	Tape and reel

Contents

1	Electrical ratings	3
2	Electrical characteristics	4
	2.1 Electrical characteristics (curves)	6
3	Test circuits	8
4	Package mechanical data	9
5	Revision history	11

1 Electrical ratings

Table 2. Absolute maximum ratings

Symbol	Parameter	Value	Unit
V_{DS}	Drain-source voltage ($V_{GS} = 0$)	55	V
V_{GS}	Gate-source voltage	± 20	V
I_D	Drain current (continuous) at $T_C = 25\text{ }^\circ\text{C}$	250	A
I_D	Drain current (continuous) at $T_C = 100\text{ }^\circ\text{C}$	175	A
$I_{DM}^{(1)}$	Drain current (pulsed)	1000	A
$P_{TOT}^{(2)}$	Total dissipation at $T_C = 25\text{ }^\circ\text{C}$	300	W
	Derating factor	2.0	W/ $^\circ\text{C}$
$E_{AS}^{(3)}$	Single pulse avalanche energy	1	J
T_{stg}	Storage temperature	-55 to 175	$^\circ\text{C}$
T_j	Operating junction temperature		

1. Pulse width limited by safe operating area
2. This value is rated according to Rthj-c
3. Starting $T_j = 25\text{ }^\circ\text{C}$, $I_D = 60\text{ A}$, $V_{DD} = 35\text{ V}$

Table 3. Thermal data

Symbol	Parameter	Value	Unit
Rthj-case	Thermal resistance junction-case max.	0.5	$^\circ\text{C}/\text{W}$
Rthj-pcb ⁽¹⁾	Thermal resistance junction-pcb max.	50	$^\circ\text{C}/\text{W}$

1. When mounted on 1 inch² FR-4 2 oz Cu

2 Electrical characteristics

($T_{\text{case}} = 25\text{ °C}$ unless otherwise specified)

Table 4. On /off states

Symbol	Parameter	Test conditions	Min.	Typ.	Max.	Unit
$V_{(BR)DSS}$	Drain-source breakdown voltage	$I_D = 250\ \mu\text{A}$, $V_{GS} = 0$	55			V
I_{DSS}	Zero gate voltage drain current ($V_{GS} = 0$)	$V_{DS} = \text{Max rating}$, $V_{DS} = \text{Max rating}$, $T_c = 125\text{ °C}$			1 10	μA μA
I_{GSS}	Gate body leakage current ($V_{DS} = 0$)	$V_{DS} = \pm 20\text{ V}$			± 100	nA
$V_{GS(th)}$	Gate threshold voltage	$V_{DS} = V_{GS}$, $I_D = 250\ \mu\text{A}$	2		4	V
$R_{DS(on)}$	Static drain-source on resistance	$V_{GS} = 10\text{ V}$, $I_D = 75\text{ A}$		1.5	2.2	$\text{m}\Omega$

Table 5. Dynamic

Symbol	Parameter	Test conditions	Min.	Typ.	Max.	Unit
C_{iss}	Input capacitance	$V_{DS} = 25\text{ V}$, $f = 1\text{ MHz}$, $V_{GS} = 0$		6800		pF
C_{oss}	Output capacitance			1450		pF
C_{rss}	Reverse transfer capacitance			15		pF
Q_g	Total gate charge	$V_{DD} = 44\text{ V}$, $I_D = 120\text{ A}$, $V_{GS} = 10\text{ V}$ <i>Figure 14</i>		100		nC
Q_{gs}	Gate-source charge			30		nC
Q_{gd}	Gate-drain charge			26		nC

Table 6. Switching times

Symbol	Parameter	Test conditions	Min.	Typ.	Max	Unit
$t_{d(on)}$ t_r	Turn-on delay time Rise time	$V_{DD} = 27.5\text{ V}$, $I_D = 60\text{ A}$ $R_G = 4.7\ \Omega$, $V_{GS} = 10\text{ V}$, Figure 13		25 150		ns ns
$t_{d(off)}$ t_f	Turn-off delay time Fall time	$V_{DD} = 27.5\text{ V}$, $I_D = 60\text{ A}$ $R_G = 4.7\ \Omega$, $V_{GS} = 10\text{ V}$, Figure 13		110 50		ns ns

Table 7. Source drain diode

Symbol	Parameter	Test conditions	Min.	Typ.	Max.	Unit
I_{SD} $I_{SD}^{(1)}$	Source-drain current Source-drain current (pulsed)				250 1000	A A
$V_{SD}^{(2)}$	Forward on voltage	$I_{SD} = 120\text{ A}$, $V_{GS} = 0$			1.5	V
t_{rr} Q_{rr} I_{RRM}	Reverse recovery time Reverse recovery charge Reverse recovery current	$I_{SD} = 120\text{ A}$, $di/dt = 100\text{ A}/\mu\text{s}$ $V_{DD} = 35\text{ V}$, $T_j = 150\text{ }^\circ\text{C}$ Figure 18		60 110 3.5		ns nC A

1. Pulse width limited by safe operating area
2. Pulsed: Pulse duration = 300 μs , duty cycle 1.5%

2.1 Electrical characteristics (curves)

Figure 2. Safe operating area

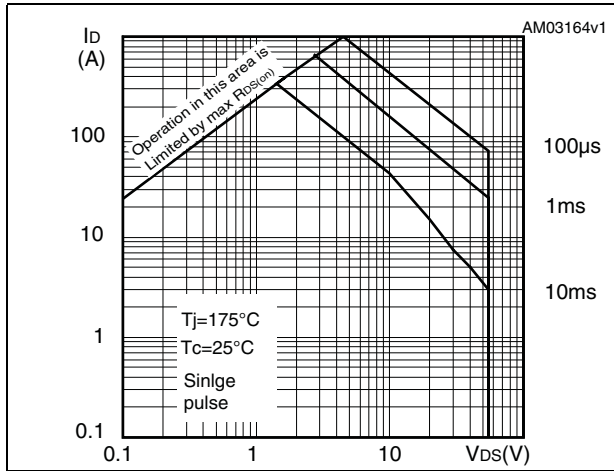

Figure 3. Thermal impedance

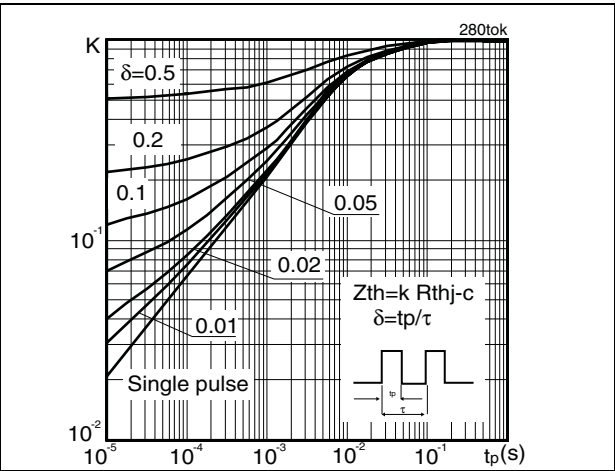

Figure 4. Output characteristics

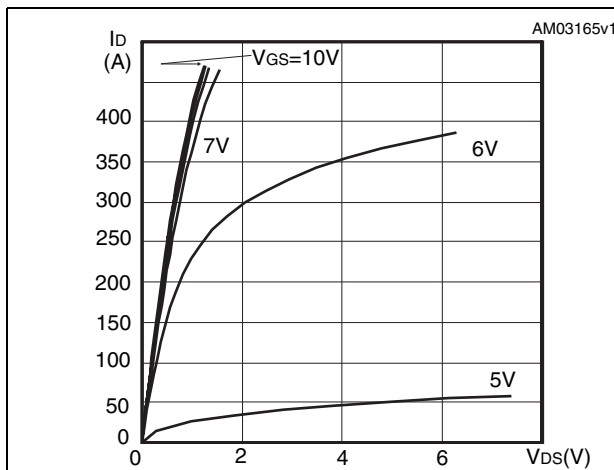

Figure 5. Transfer characteristics

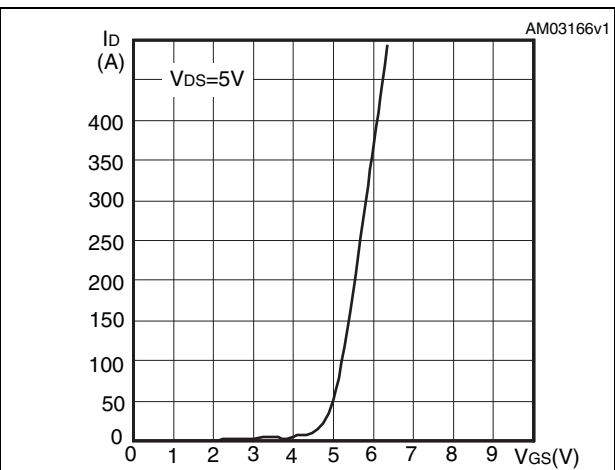

Figure 6. Normalized $B_{V_{DS}}$ vs temperature

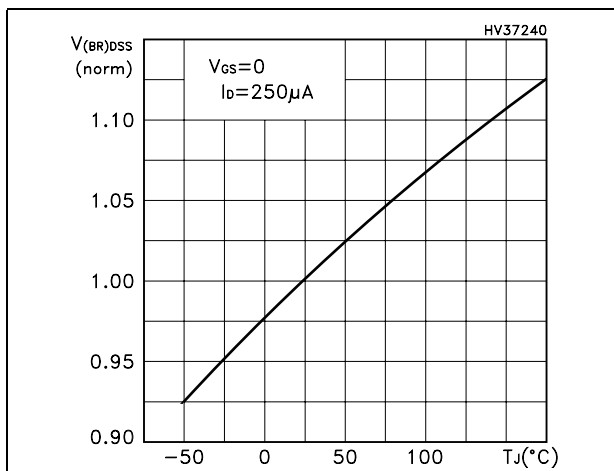

Figure 7. Static drain-source on resistance

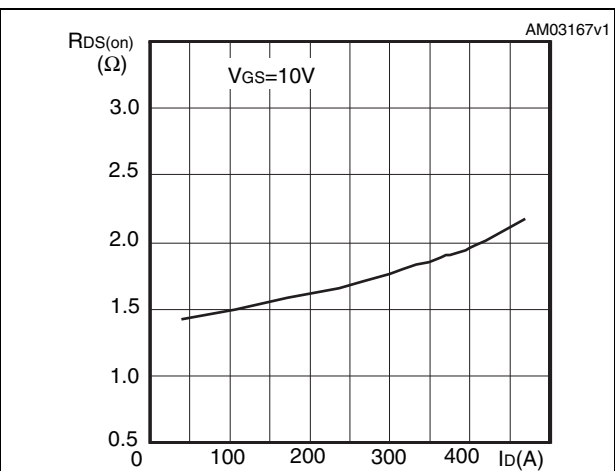

Figure 8. Gate charge vs gate-source voltage Figure 9. Capacitance variations

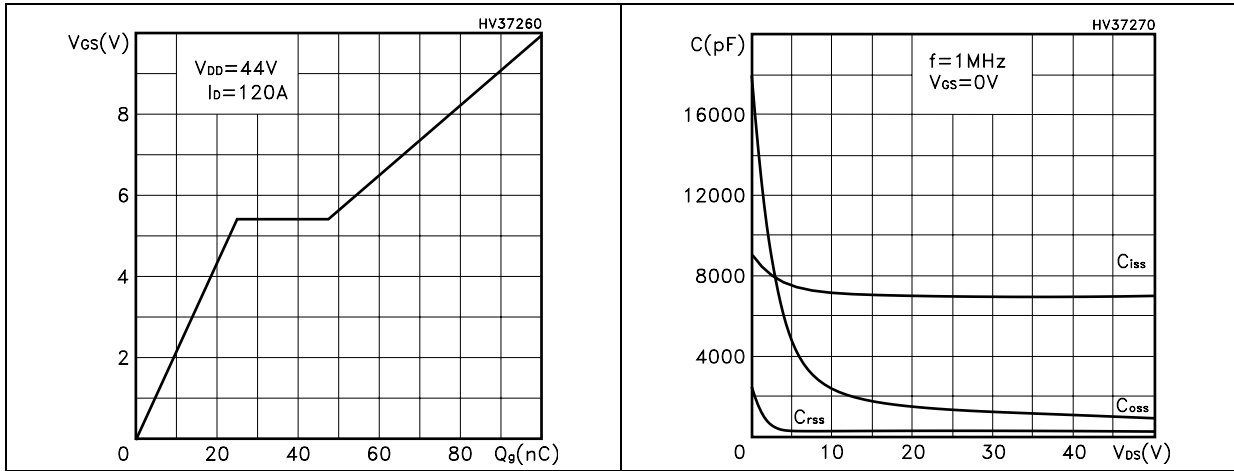

Figure 10. Normalized gate threshold voltage vs temperature Figure 11. Normalized on resistance vs temperature

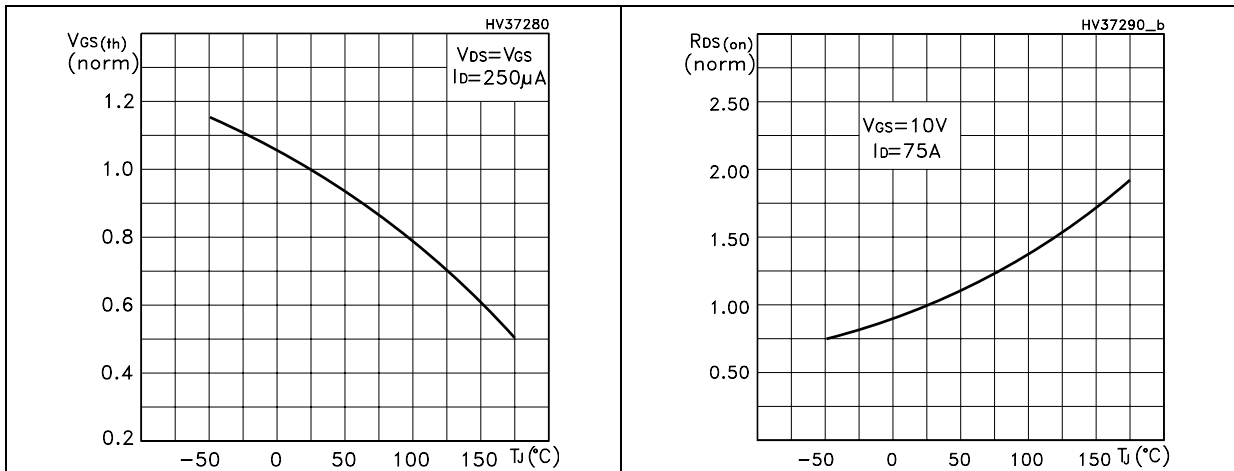
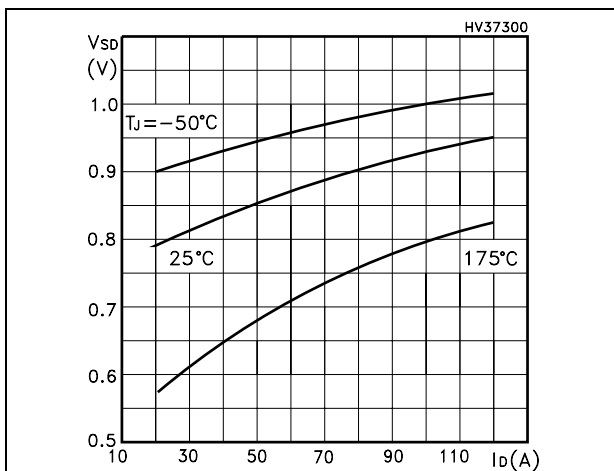

Figure 12. Source-drain diode forward characteristics



3 Test circuits

Figure 13. Switching times test circuit for resistive load

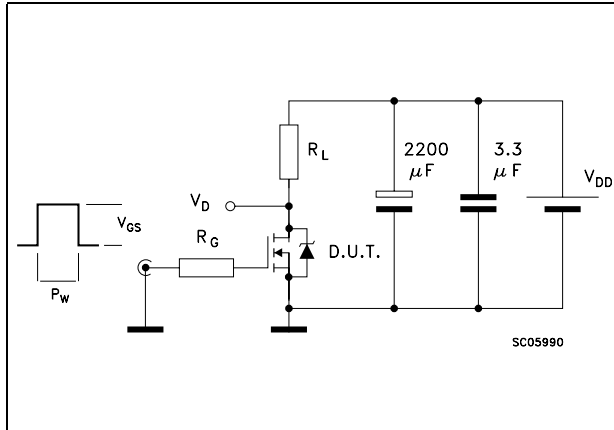

Figure 14. Gate charge test circuit

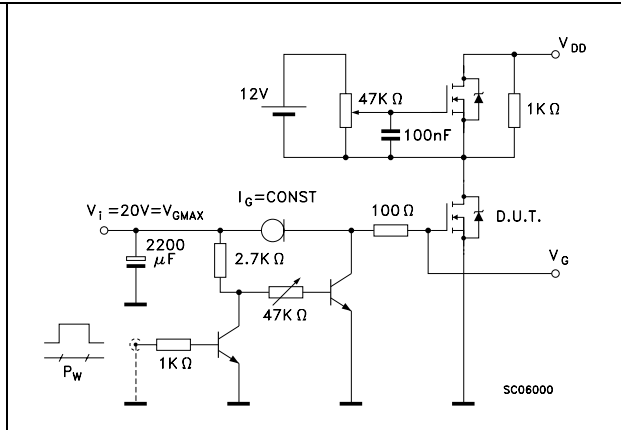

Figure 15. Test circuit for inductive load switching and diode recovery times

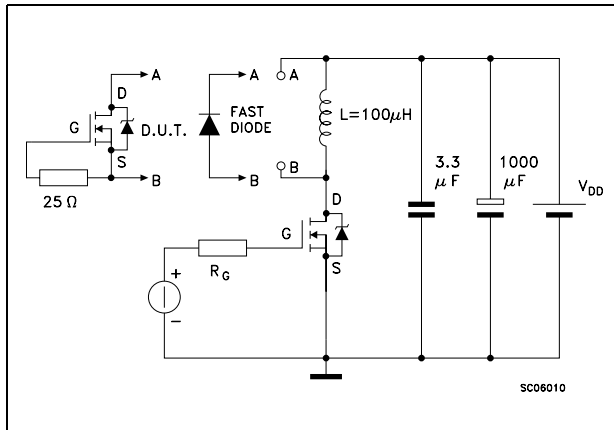

Figure 16. Unclamped inductive load test circuit

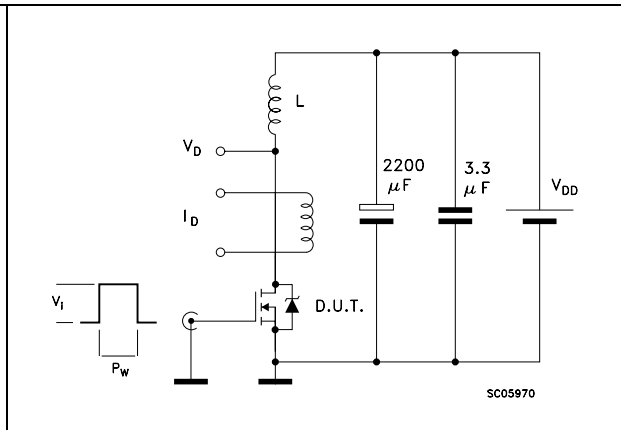

Figure 17. Unclamped inductive waveform

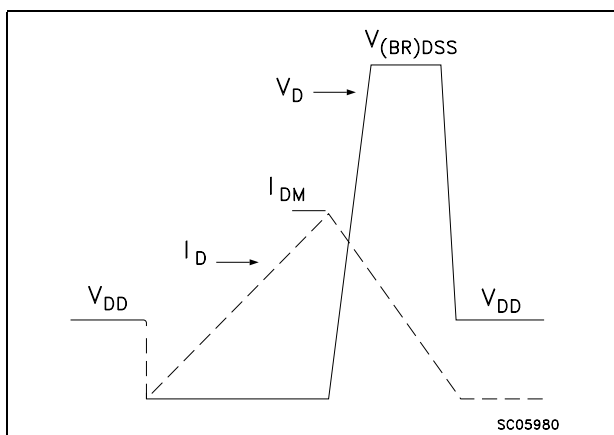
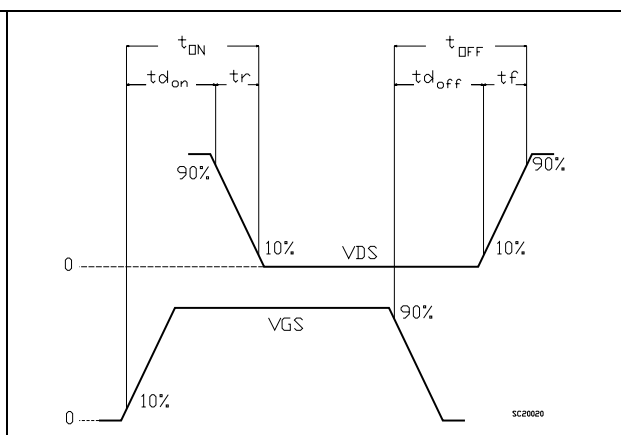

Figure 18. Switching time waveform



4 Package mechanical data

In order to meet environmental requirements, ST offers these devices in different grades of ECOPACK® packages, depending on their level of environmental compliance. ECOPACK® specifications, grade definitions and product status are available at: www.st.com. ECOPACK is an ST trademark.

PowerSO-10 mechanical data

Dim	mm		
	Min	Typ	Max
A			3.70
A1	0.00		0.10
A2	3.40		3.60
A3	1.25		1.35
b	0.40		0.53
c	0.35		0.55
D	9.40		9.60
D1	7.40		7.60
E	13.80		14.40
E1	9.30		9.50
E2	7.20		7.60
E3	5.90		6.10
e		1.27	
L	0.95		1.65
<	0°		8°

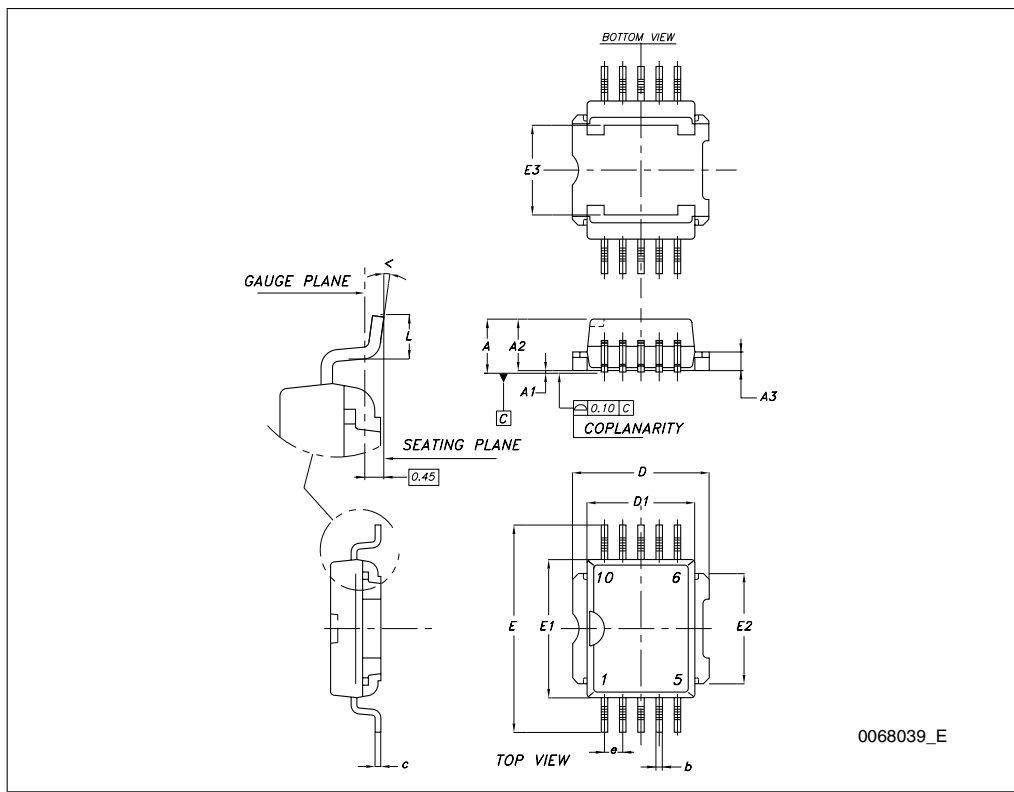

5 Revision history

Table 8. Document revision history

Date	Revision	Changes
25-Oct-2007	1	Initial release
20-Mar-2008	2	Content reworked to improve readability, no technical changes.
10-Nov-2008	3	Document status promoted from preliminary data to datasheet.
02-Mar-2009	4	<i>Figure 2</i> has been updated.

Please Read Carefully:

Information in this document is provided solely in connection with ST products. STMicroelectronics NV and its subsidiaries ("ST") reserve the right to make changes, corrections, modifications or improvements, to this document, and the products and services described herein at any time, without notice.

All ST products are sold pursuant to ST's terms and conditions of sale.

Purchasers are solely responsible for the choice, selection and use of the ST products and services described herein, and ST assumes no liability whatsoever relating to the choice, selection or use of the ST products and services described herein.

No license, express or implied, by estoppel or otherwise, to any intellectual property rights is granted under this document. If any part of this document refers to any third party products or services it shall not be deemed a license grant by ST for the use of such third party products or services, or any intellectual property contained therein or considered as a warranty covering the use in any manner whatsoever of such third party products or services or any intellectual property contained therein.

UNLESS OTHERWISE SET FORTH IN ST'S TERMS AND CONDITIONS OF SALE ST DISCLAIMS ANY EXPRESS OR IMPLIED WARRANTY WITH RESPECT TO THE USE AND/OR SALE OF ST PRODUCTS INCLUDING WITHOUT LIMITATION IMPLIED WARRANTIES OF MERCHANTABILITY, FITNESS FOR A PARTICULAR PURPOSE (AND THEIR EQUIVALENTS UNDER THE LAWS OF ANY JURISDICTION), OR INFRINGEMENT OF ANY PATENT, COPYRIGHT OR OTHER INTELLECTUAL PROPERTY RIGHT.

UNLESS EXPRESSLY APPROVED IN WRITING BY AN AUTHORIZED ST REPRESENTATIVE, ST PRODUCTS ARE NOT RECOMMENDED, AUTHORIZED OR WARRANTED FOR USE IN MILITARY, AIR CRAFT, SPACE, LIFE SAVING, OR LIFE SUSTAINING APPLICATIONS, NOR IN PRODUCTS OR SYSTEMS WHERE FAILURE OR MALFUNCTION MAY RESULT IN PERSONAL INJURY, DEATH, OR SEVERE PROPERTY OR ENVIRONMENTAL DAMAGE. ST PRODUCTS WHICH ARE NOT SPECIFIED AS "AUTOMOTIVE GRADE" MAY ONLY BE USED IN AUTOMOTIVE APPLICATIONS AT USER'S OWN RISK.

Resale of ST products with provisions different from the statements and/or technical features set forth in this document shall immediately void any warranty granted by ST for the ST product or service described herein and shall not create or extend in any manner whatsoever, any liability of ST.

ST and the ST logo are trademarks or registered trademarks of ST in various countries.

Information in this document supersedes and replaces all information previously supplied.

The ST logo is a registered trademark of STMicroelectronics. All other names are the property of their respective owners.

© 2009 STMicroelectronics - All rights reserved

STMicroelectronics group of companies

Australia - Belgium - Brazil - Canada - China - Czech Republic - Finland - France - Germany - Hong Kong - India - Israel - Italy - Japan - Malaysia - Malta - Morocco - Singapore - Spain - Sweden - Switzerland - United Kingdom - United States of America

www.st.com