

2-line IPAD™, EMI filter including ESD protection

Features

- 2-line, low-pass filter + 2-line ESD protection
- High efficiency in EMI filtering
- Lead-free package
- Very low PCB space occupation: < 2.80 mm²
- Very thin package: 0.65 mm
- High efficiency in ESD suppression (IEC 61000-4-2 level 4)
- High reliability offered by monolithic integration
- High reduction of parasitic elements through integration and wafer level packaging

Complies with the following standards

- IEC 61000-4-2 level 4 on external pins:
 - 15 kV (air discharge)
 - 8 kV (contact discharge)
- IEC 61000-4-2 level 1 on internal pins:
 - 2 kV (air discharge)
 - 2 kV (contact discharge)

Application

ESD protection and EMI filtering for:

- USB OTG port

Description

The EMIF02-USB03F2 is a highly integrated array designed to suppress EMI / RFI noise for USB OTG (on-the-go) ports.

The EMIF02-USB03F2 Flip-Chip packaging means the package size is equal to the die size.

Additionally, this filter includes ESD protection circuitry which prevents damage to the protected device when subjected to ESD surges up to 15 kV on external contacts.

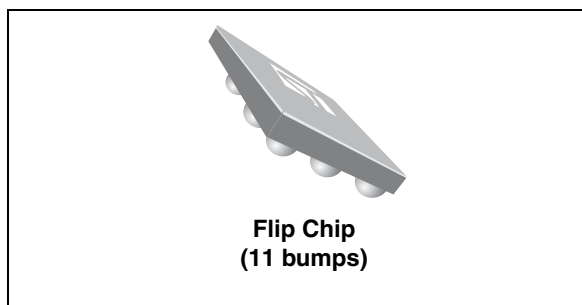

Figure 1. Pin layout (bump side)

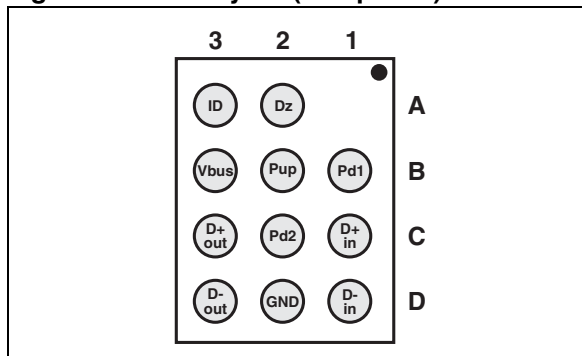
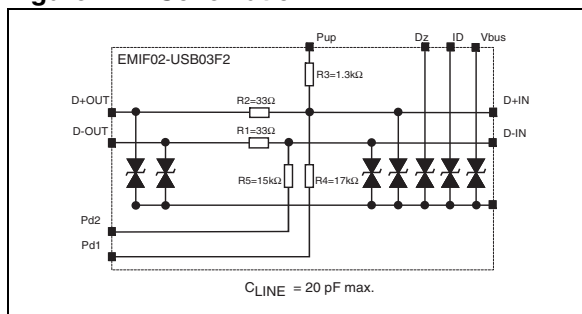

Figure 2. Schematic



TM: IPAD is a trademark of STMicroelectronics.

1 Characteristics

Table 1. Absolute ratings ($T_{amb} = 25\text{ }^{\circ}\text{C}$)

Symbol	Parameter and test conditions	Value	Unit
V_{PP}	Internal pins (D3, C3, C2, B2, B1):		
	ESD discharge IEC61000-4-2, air discharge	2	kV
	ESD discharge IEC61000-4-2, contact discharge	2	
	External pins (D1, C1, A2, A3, B3):		
ESD discharge IEC61000-4-2, air discharge	15		
	ESD discharge IEC61000-4-2, contact discharge	8	
T_j	Maximum junction temperature	125	$^{\circ}\text{C}$
T_{op}	Operating temperature range	-40 to +85	$^{\circ}\text{C}$
T_{stg}	Storage temperature range	-55 to 150	$^{\circ}\text{C}$

Table 2. Electrical characteristics ($T_{amb} = 25\text{ }^{\circ}\text{C}$)

Symbol	Parameters				
V_{BR}	Breakdown voltage				
I_{RM}	Leakage current @ V_{RM}				
V_{RM}	Stand-off voltage				
V_{CL}	Clamping voltage				
R_d	Dynamic impedance				
I_{PP}	Peak pulse current				
C_{LINE}	Input capacitance per line				
Symbol	Test conditions	Min	Typ	Max	Unit
V_{BR}	$I_R = 1\text{ mA}$	14			V
I_{RM}	$V_{RM} = 3\text{ V}$			0.2	μA
C_{LINE}	$V_{LINE} = 0\text{ V}$, $V_{OSC} = 30\text{ mV}$, $F = 1\text{ MHz}$, measured in zero light condition			20	pF
R_1, R_2	Tolerance $\pm 5\%$		33		Ω
R_3	Tolerance $\pm 5\%$		1.30		k Ω
R_4	Tolerance $\pm 5\%$		17		k Ω
R_5	Tolerance $\pm 5\%$		15		k Ω

Figure 3. Filtering measurement

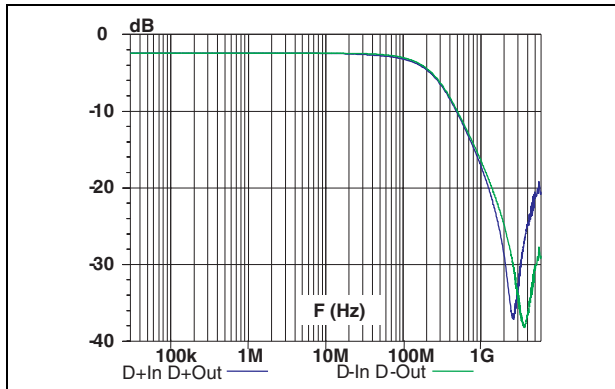

Figure 4. Analog crosstalk measurement

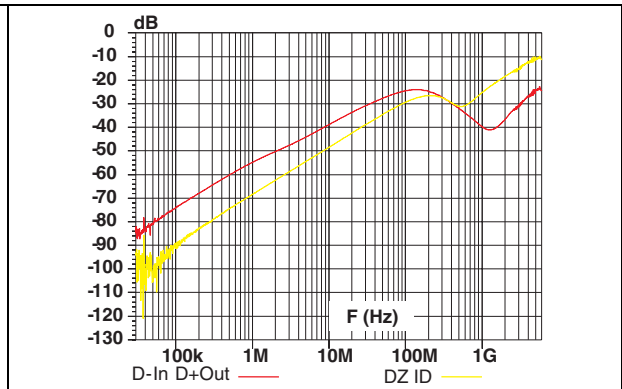

Figure 5. ESD response to IEC 61000-4-2 (+15 kV air discharge) on one input V_{in} and on one output V_{out}

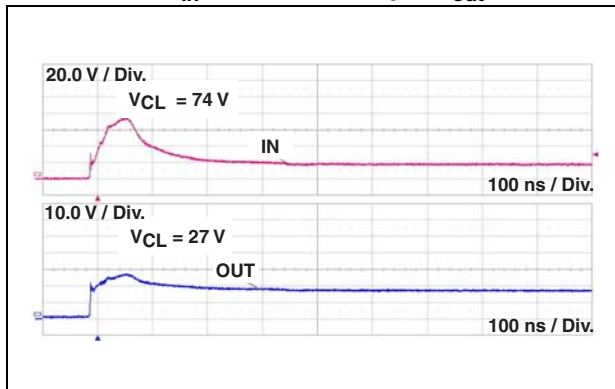

Figure 6. ESD response to IEC 61000-4-2 (-15 kV air discharge) on one input V_{in} and on one output V_{out}

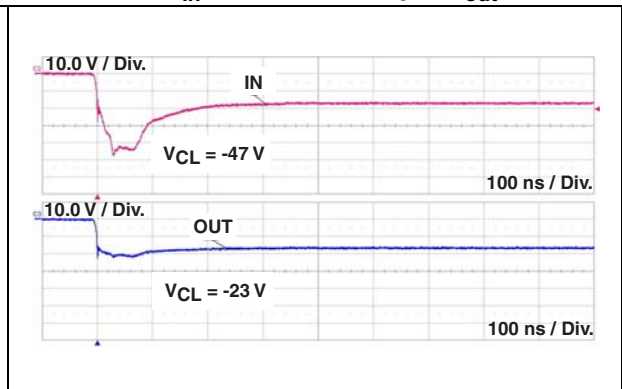
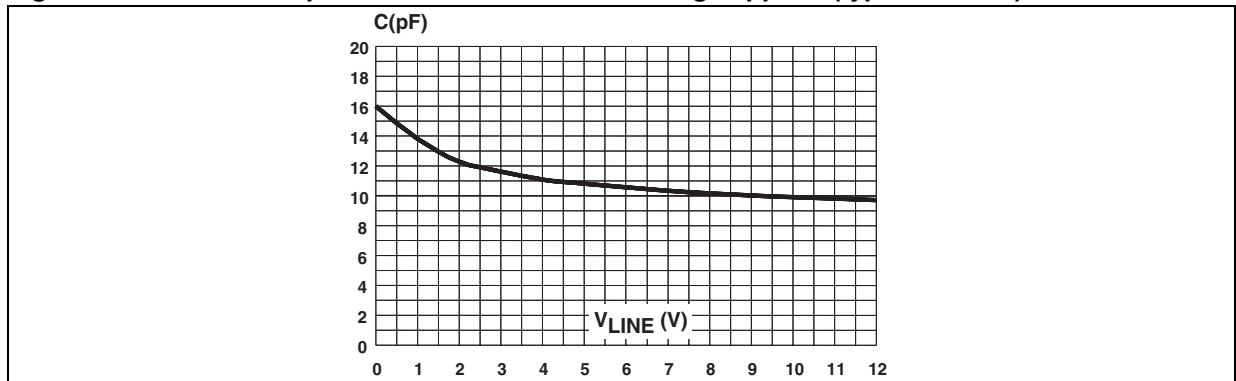

Figure 7. Junction capacitance versus reverse voltage applied (typical values)



2 Application information

Figure 8. Application schematic

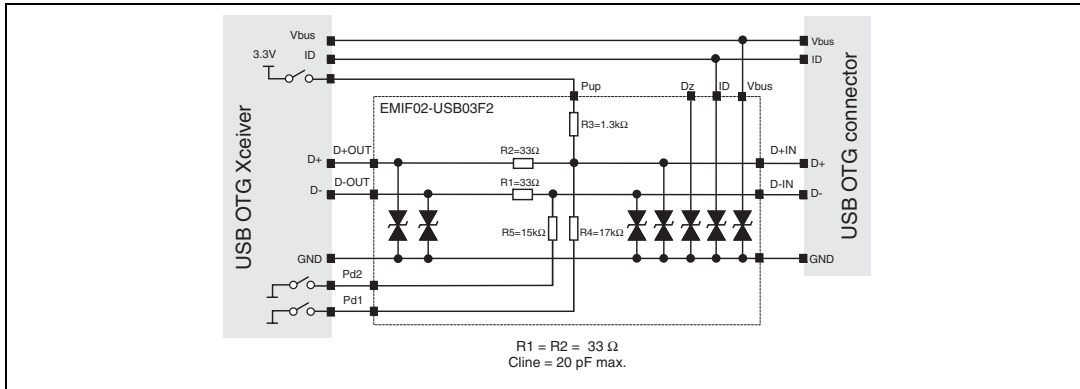

Figure 9. Aplac model

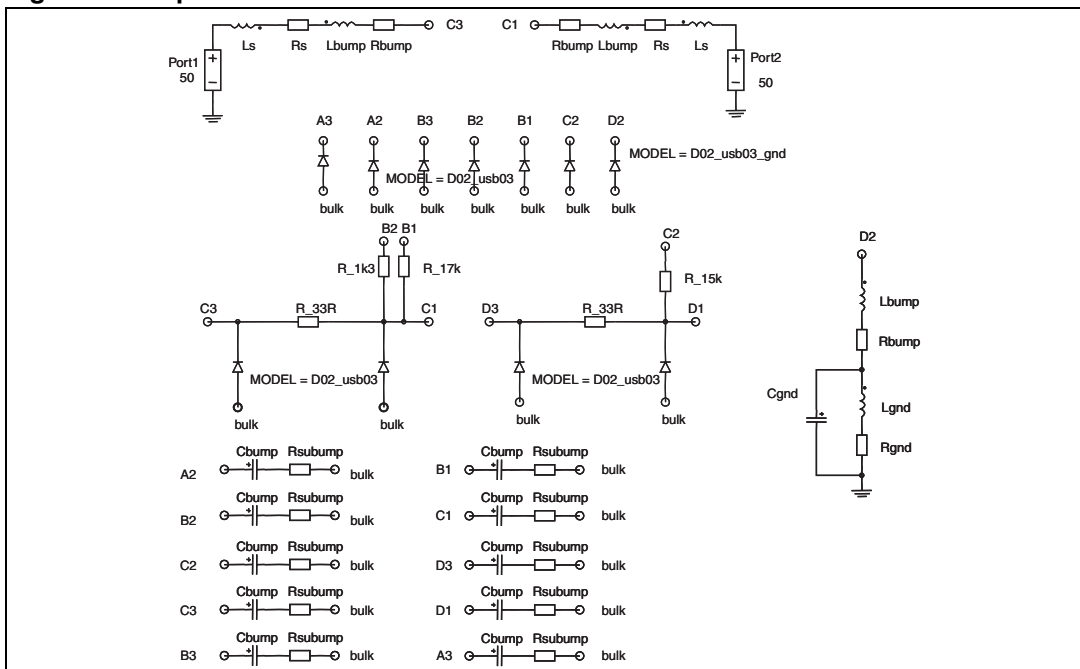
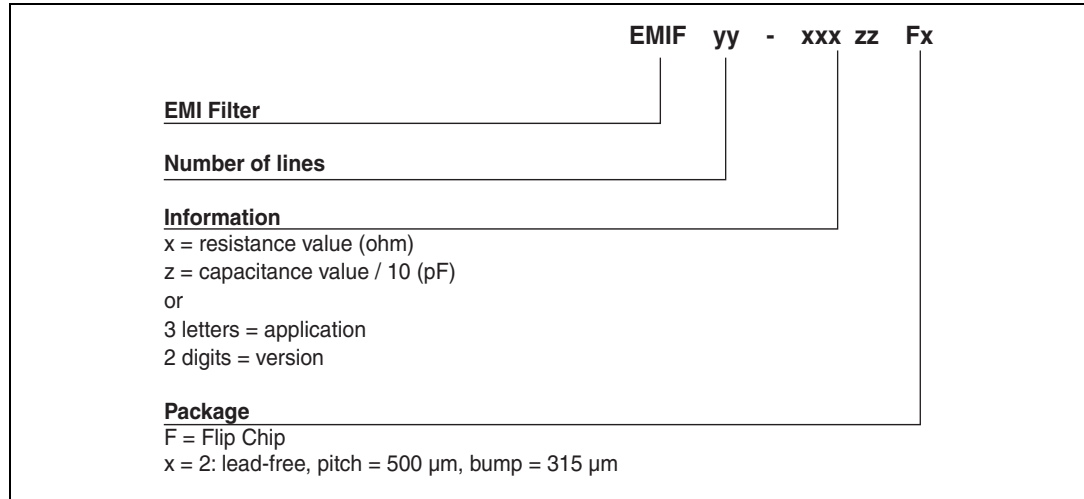

Figure 10. Aplac parameters

Ls	950pH	Rs_usb03_gnd	0.9
Rs	150m	Lgnd	50pH
R_33R	33	Rgnd	100m
R_1k3	1.3k	Cgnd	0.15pF
R_15k	15k	Lbump	50pH
R_17k	17k	Rbump	20m
Cz_usb03	11pF	Cbump	2.4pF
Rs_usb03	1	Rsubump	100m
Cz_usb03_gnd	220pF		

3 Ordering information scheme

Figure 11. Ordering information scheme



4 Package information

In order to meet environmental requirements, ST offers these devices in different grades of ECOPACK® packages, depending on their level of environmental compliance. ECOPACK® specifications, grade definitions and product status are available at: www.st.com. ECOPACK® is an ST trademark.

Figure 12. Package dimensions

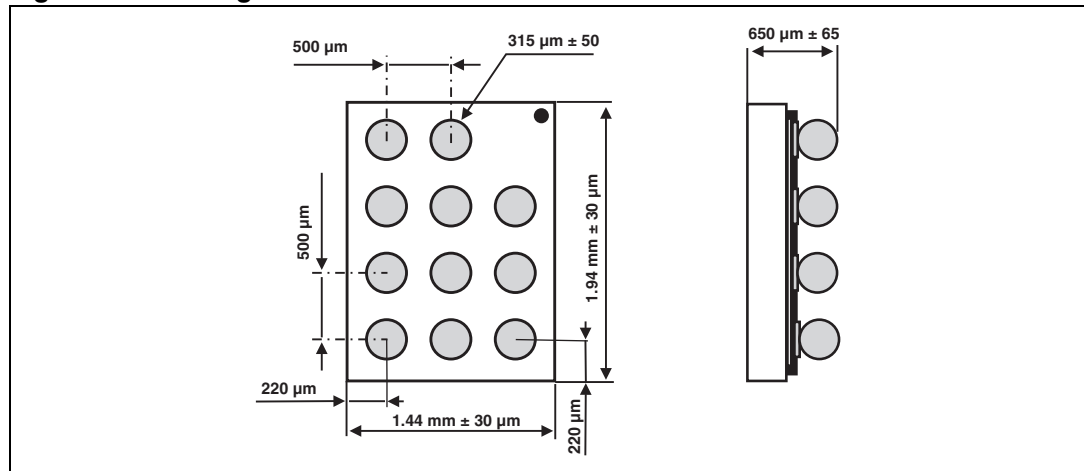

Figure 13. Footprint

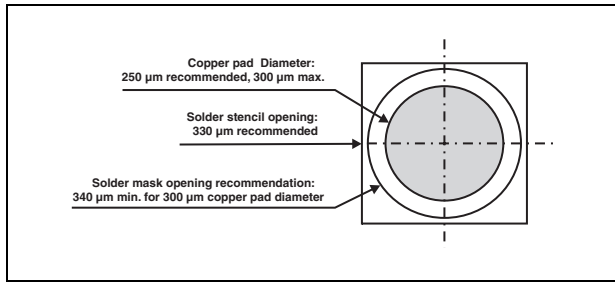

Figure 14. Marking

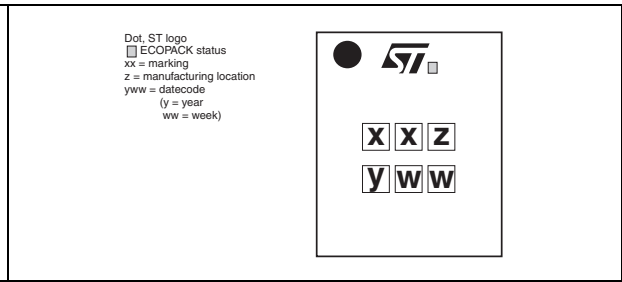
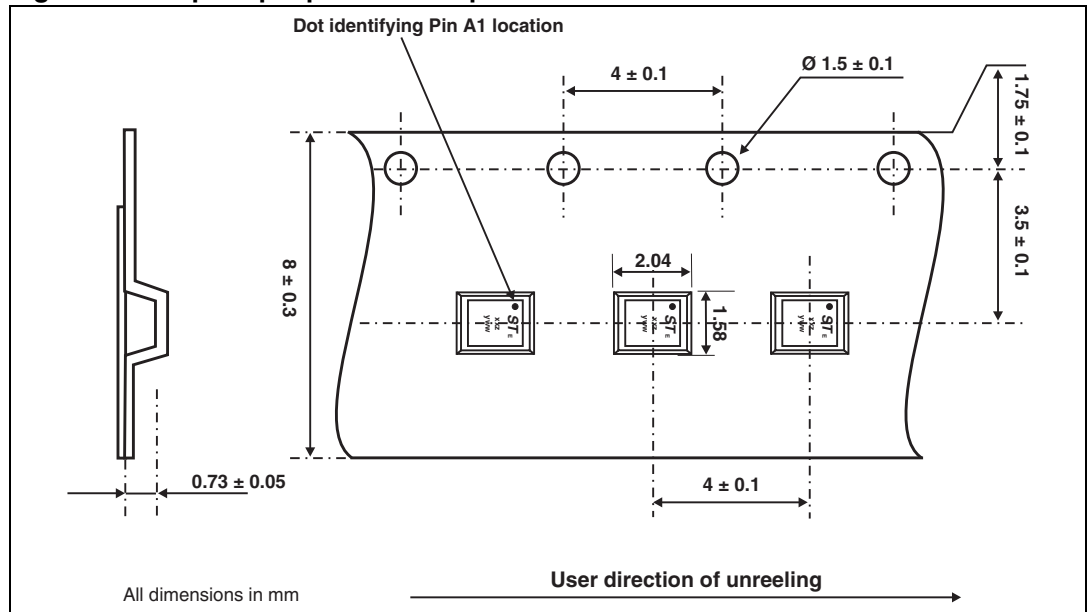

Figure 15. Flip Chip tape and reel specification



Note: More information is available in the application notes:
 AN1235: "Flip Chip: Package description and recommendations for use"
 AN1751: "EMI filters: Recommendations and measurements"

5 Ordering information

Table 3. Ordering information

Order code	Marking	Package	Weight	Base qty	Delivery mode
EMIF02-USB03F2	FU	Flip Chip	4 mg	5000	Tape and reel 7"

6 Revision history

Table 4. Document revision history

Date	Revision	Changes
14-Oct-2004	1	Initial release.
25-Oct-2004	2	<i>Figure 14.</i> : Flip Chip marking dimensions updated.
27-Oct-2004	3	Minor layout update. No content change.
28-Apr-2008	4	Updated ECOPACK statement. Updated <i>Figure 11</i> , <i>Figure 12</i> , <i>Figure 13</i> , <i>Figure 14</i> and <i>Figure 15</i> . Reformatted to current standards.
08-Feb-2010	5	Updated the maximum value of I_{RM} in <i>Table 2</i> . Updated <i>Figure 12</i> and <i>Figure 15</i> for die dimension reductions.

Please Read Carefully:

Information in this document is provided solely in connection with ST products. STMicroelectronics NV and its subsidiaries ("ST") reserve the right to make changes, corrections, modifications or improvements, to this document, and the products and services described herein at any time, without notice.

All ST products are sold pursuant to ST's terms and conditions of sale.

Purchasers are solely responsible for the choice, selection and use of the ST products and services described herein, and ST assumes no liability whatsoever relating to the choice, selection or use of the ST products and services described herein.

No license, express or implied, by estoppel or otherwise, to any intellectual property rights is granted under this document. If any part of this document refers to any third party products or services it shall not be deemed a license grant by ST for the use of such third party products or services, or any intellectual property contained therein or considered as a warranty covering the use in any manner whatsoever of such third party products or services or any intellectual property contained therein.

UNLESS OTHERWISE SET FORTH IN ST'S TERMS AND CONDITIONS OF SALE ST DISCLAIMS ANY EXPRESS OR IMPLIED WARRANTY WITH RESPECT TO THE USE AND/OR SALE OF ST PRODUCTS INCLUDING WITHOUT LIMITATION IMPLIED WARRANTIES OF MERCHANTABILITY, FITNESS FOR A PARTICULAR PURPOSE (AND THEIR EQUIVALENTS UNDER THE LAWS OF ANY JURISDICTION), OR INFRINGEMENT OF ANY PATENT, COPYRIGHT OR OTHER INTELLECTUAL PROPERTY RIGHT.

UNLESS EXPRESSLY APPROVED IN WRITING BY AN AUTHORIZED ST REPRESENTATIVE, ST PRODUCTS ARE NOT RECOMMENDED, AUTHORIZED OR WARRANTED FOR USE IN MILITARY, AIR CRAFT, SPACE, LIFE SAVING, OR LIFE SUSTAINING APPLICATIONS, NOR IN PRODUCTS OR SYSTEMS WHERE FAILURE OR MALFUNCTION MAY RESULT IN PERSONAL INJURY, DEATH, OR SEVERE PROPERTY OR ENVIRONMENTAL DAMAGE. ST PRODUCTS WHICH ARE NOT SPECIFIED AS "AUTOMOTIVE GRADE" MAY ONLY BE USED IN AUTOMOTIVE APPLICATIONS AT USER'S OWN RISK.

Resale of ST products with provisions different from the statements and/or technical features set forth in this document shall immediately void any warranty granted by ST for the ST product or service described herein and shall not create or extend in any manner whatsoever, any liability of ST.

ST and the ST logo are trademarks or registered trademarks of ST in various countries.

Information in this document supersedes and replaces all information previously supplied.

The ST logo is a registered trademark of STMicroelectronics. All other names are the property of their respective owners.

© 2010 STMicroelectronics - All rights reserved

STMicroelectronics group of companies

Australia - Belgium - Brazil - Canada - China - Czech Republic - Finland - France - Germany - Hong Kong - India - Israel - Italy - Japan - Malaysia - Malta - Morocco - Philippines - Singapore - Spain - Sweden - Switzerland - United Kingdom - United States of America

www.st.com