

## N-channel 30 V, 2.5 mΩ typ., 120 A STripFET™ H6 Power MOSFET in a TO-220 package

Datasheet - production data

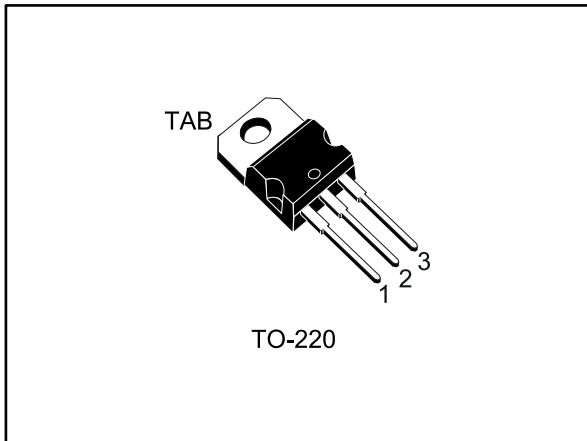
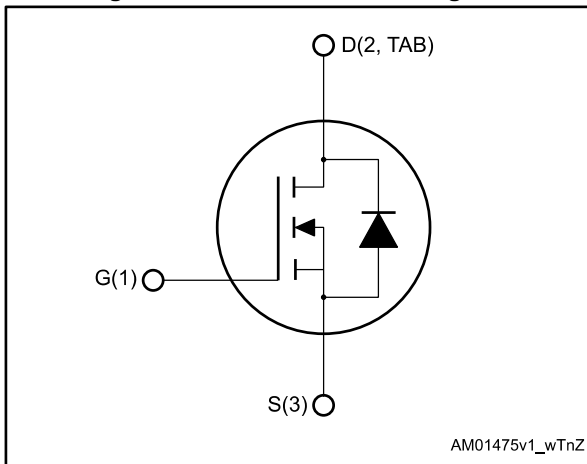

Figure 1: Internal schematic diagram



### Features

Order code	V <sub>DS</sub>	R <sub>DS(on)</sub> max.	I <sub>D</sub>	P <sub>TOT</sub>
STP160N3LL	30 V	3.2 mΩ	120 A	136 W

- Very low on-resistance
- Very low gate charge
- High avalanche ruggedness
- Low gate drive power loss

### Applications

- Switching applications

### Description

This device is an N-channel Power MOSFET developed using the STripFET™ H6 technology with a new trench gate structure. The resulting Power MOSFET exhibits very low R<sub>DS(on)</sub> in all packages.

Table 1: Device summary

Order code	Marking	Package	Packing
STP160N3LL	160N3LL	TO-220	Tube

---

**Contents**

<b>1</b>	<b>Electrical ratings .....</b>	<b>3</b>
<b>2</b>	<b>Electrical characteristics .....</b>	<b>4</b>
	2.1 Electrical characteristics (curves).....	6
<b>3</b>	<b>Test circuits .....</b>	<b>8</b>
<b>4</b>	<b>Package information .....</b>	<b>9</b>
	4.1 TO-220 type A package information.....	10
<b>5</b>	<b>Revision history .....</b>	<b>12</b>

# 1 Electrical ratings

**Table 2: Absolute maximum ratings**

Symbol	Parameter	Value	Unit
$V_{DS}$	Drain-source voltage	30	V
$V_{GS}$	Gate-source voltage	$\pm 20$	V
$I_D^{(1)}$	Drain current (continuous) at $T_{case} = 25\text{ }^\circ\text{C}$	120	A
$I_D$	Drain current (continuous) at $T_{case} = 100\text{ }^\circ\text{C}$	112	
$I_{DM}^{(2)}$	Drain current (pulsed)	480	
$P_{TOT}$	Total dissipation at $T_{case} = 25\text{ }^\circ\text{C}$	136	W
$E_{AS}^{(3)}$	Single pulse avalanche energy	150	mJ
$T_{stg}$	Storage temperature	-55 to 175	$^\circ\text{C}$
$T_j$	Operating junction temperature		

**Notes:**

<sup>(1)</sup> Current is limited by package.

<sup>(2)</sup> Pulse width is limited by safe operating area.

<sup>(3)</sup> starting  $T_j = 25\text{ }^\circ\text{C}$ ,  $I_D = 40\text{ A}$

**Table 3: Thermal data**

Symbol	Parameter	Value	Unit
$R_{thj-case}$	Thermal resistance junction-case	1.1	$^\circ\text{C/W}$
$R_{thj-amb}$	Thermal resistance junction-ambient	62.5	

## 2 Electrical characteristics

( $T_{\text{case}} = 25\text{ °C}$  unless otherwise specified)

**Table 4: Static**

Symbol	Parameter	Test conditions	Min.	Typ.	Max.	Unit
$V_{(\text{BR})\text{DSS}}$	Drain-source breakdown voltage	$V_{\text{GS}} = 0\text{ V}$ , $I_{\text{D}} = 250\text{ }\mu\text{A}$	30			V
$I_{\text{DSS}}$	Zero gate voltage drain current	$V_{\text{GS}} = 0\text{ V}$ , $V_{\text{DS}} = 30\text{ V}$			1	$\mu\text{A}$
		$V_{\text{GS}} = 0\text{ V}$ , $V_{\text{DS}} = 30\text{ V}$ , $T_{\text{case}} = 125\text{ °C}$			10	
$I_{\text{GSS}}$	Gate-body leakage current	$V_{\text{DS}} = 0\text{ V}$ , $V_{\text{GS}} = \pm 20\text{ V}$			$\pm 100$	nA
$V_{\text{GS}(\text{th})}$	Gate threshold voltage	$V_{\text{DS}} = V_{\text{GS}}$ , $I_{\text{D}} = 250\text{ }\mu\text{A}$	1		2.5	V
$R_{\text{DS}(\text{on})}$	Static drain-source on-resistance	$V_{\text{GS}} = 10\text{ V}$ , $I_{\text{D}} = 60\text{ A}$		2.5	3.2	m $\Omega$
		$V_{\text{GS}} = 4.5\text{ V}$ , $I_{\text{D}} = 60\text{ A}$		3.2	4.2	

**Table 5: Dynamic**

Symbol	Parameter	Test conditions	Min.	Typ.	Max.	Unit
$C_{\text{ISS}}$	Input capacitance	$V_{\text{DS}} = 25\text{ V}$ , $f = 1\text{ MHz}$ , $V_{\text{GS}} = 0\text{ V}$	-	3500	-	pF
$C_{\text{OSS}}$	Output capacitance		-	400	-	
$C_{\text{RSS}}$	Reverse transfer capacitance		-	380	-	
$Q_{\text{g}}$	Total gate charge	$V_{\text{DD}} = 15\text{ V}$ , $I_{\text{D}} = 120\text{ A}$ , $V_{\text{GS}} = 4.5\text{ V}$ (see <a href="#">Figure 14: "Gate charge test circuit"</a> )	-	42	-	nC
$Q_{\text{gs}}$	Gate-source charge		-	9	-	
$Q_{\text{gd}}$	Gate-drain charge		-	18	-	
$R_{\text{G}}$	Intrinsic gate resistance	$f = 1\text{ MHz}$ , $I_{\text{D}} = 0\text{ A}$ , gate DC bias = $0\text{ V}$ , magnitude of alternative signal = $20\text{ mV}$	-	1	-	$\Omega$

**Table 6: Switching times**

Symbol	Parameter	Test conditions	Min.	Typ.	Max.	Unit
$t_{\text{d}(\text{on})}$	Turn-on delay time	$V_{\text{DD}} = 15\text{ V}$ , $I_{\text{D}} = 60\text{ A}$ $R_{\text{G}} = 4.7\text{ }\Omega$ , $V_{\text{GS}} = 5\text{ V}$ (see <a href="#">Figure 13: "Switching times test circuit for resistive load"</a> and <a href="#">Figure 18: "Switching time waveform"</a> )	-	19	-	ns
$t_{\text{r}}$	Rise time		-	91	-	
$t_{\text{d}(\text{off})}$	Turn-off delay time		-	24.5	-	
$t_{\text{f}}$	Fall time		-	23.4	-	

Table 7: Source-drain diode

Symbol	Parameter	Test conditions	Min.	Typ.	Max.	Unit
$V_{SD}^{(1)}$	Forward on voltage	$V_{GS} = 0 \text{ V}$ , $I_{SD} = 60 \text{ A}$	-		1.1	V
$t_{rr}$	Reverse recovery time	$I_{SD} = 120 \text{ A}$ , $di/dt = 100 \text{ A}/\mu\text{s}$ , $V_{DD} = 24 \text{ V}$ (see <a href="#">Figure 15: "Test circuit for inductive load switching and diode recovery times"</a> )	-	28.6		ns
$Q_{rr}$	Reverse recovery charge		-	22.8		nC
$I_{RRM}$	Reverse recovery current		-	1.6		A

**Notes:**

<sup>(1)</sup> Pulse test: pulse duration = 300  $\mu\text{s}$ , duty cycle 1.5%.

2.1 Electrical characteristics (curves)

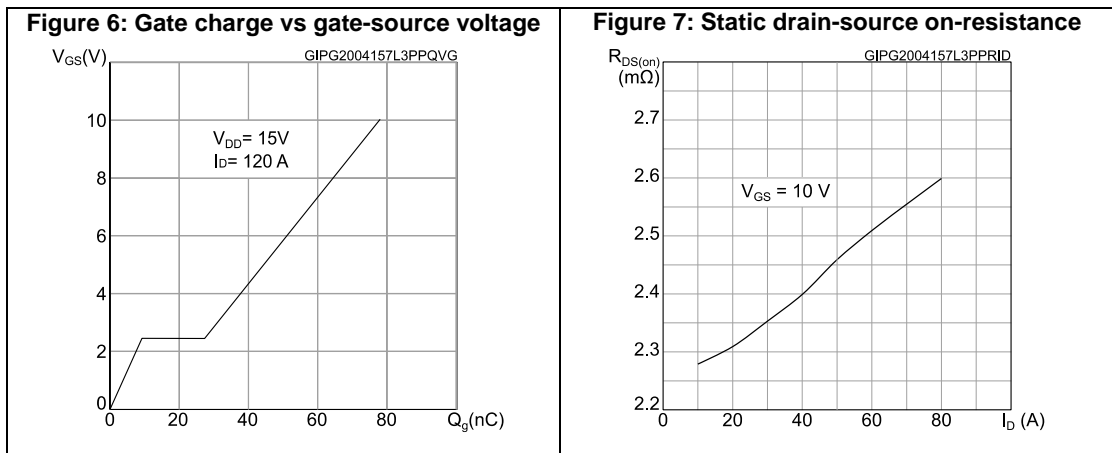
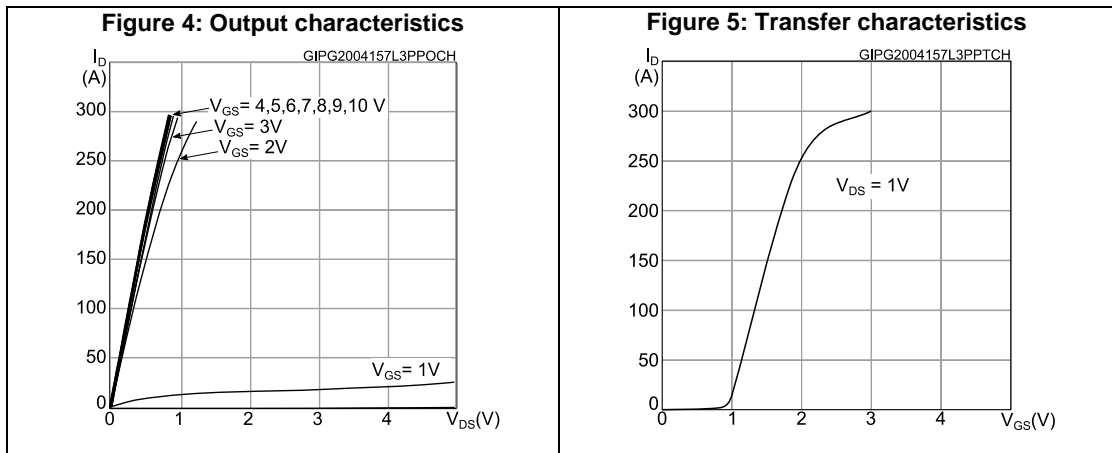
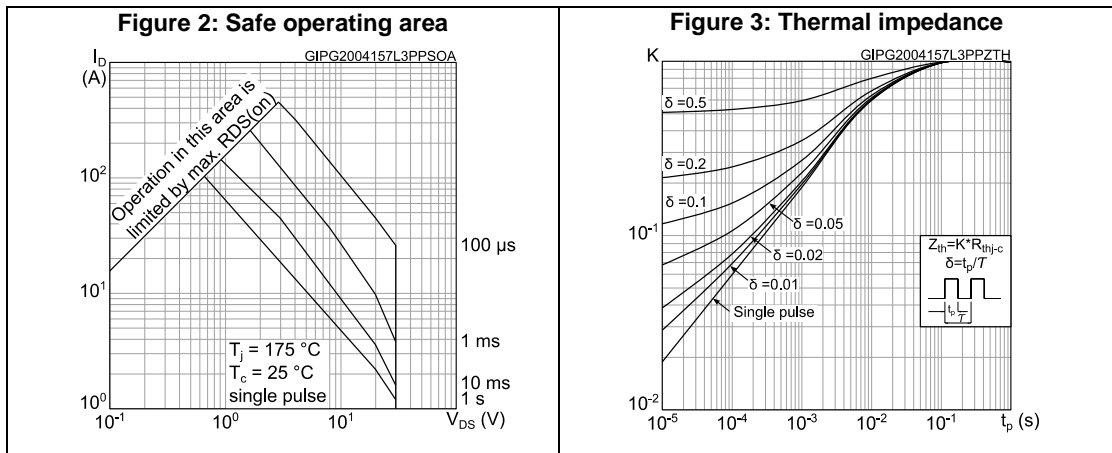

Figure 8: Capacitance variations

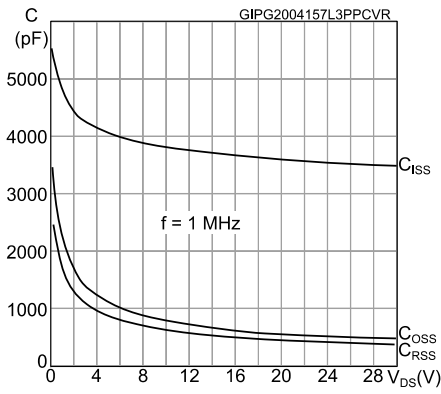

Figure 9: Normalized gate threshold voltage vs temperature

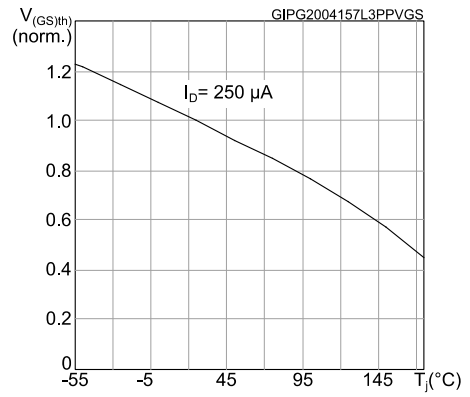

Figure 10: Normalized on-resistance vs temperature

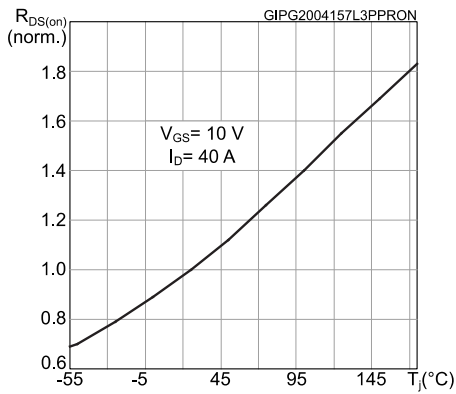

Figure 11: Normalized  $V_{(BR)DSS}$  vs temperature

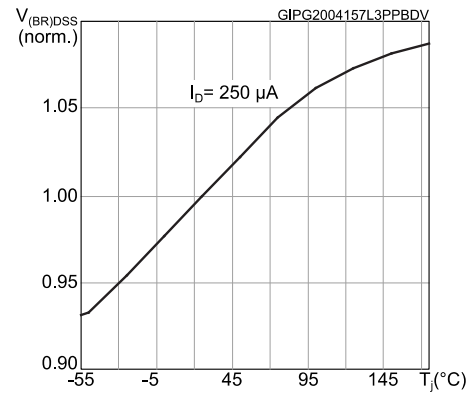
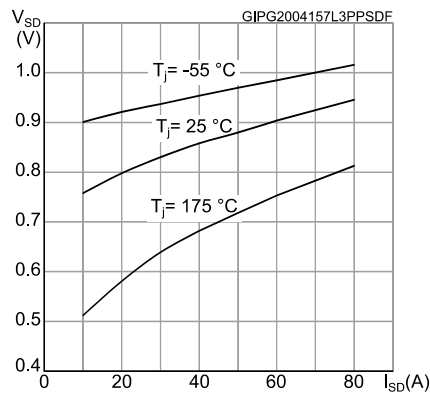
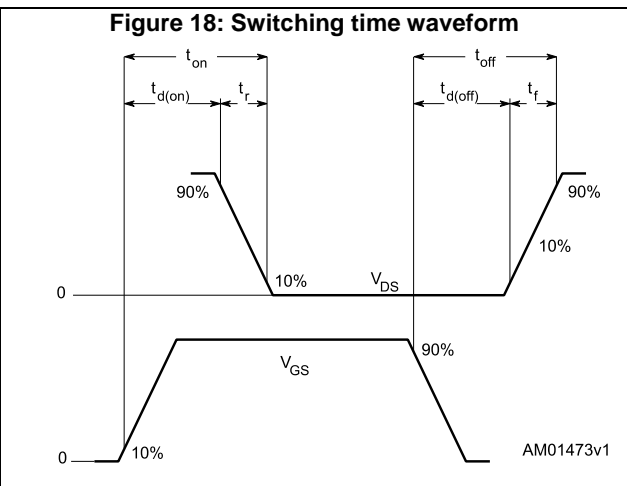
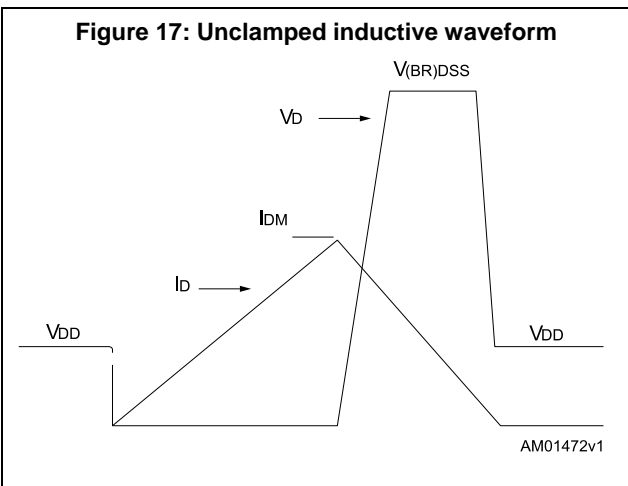
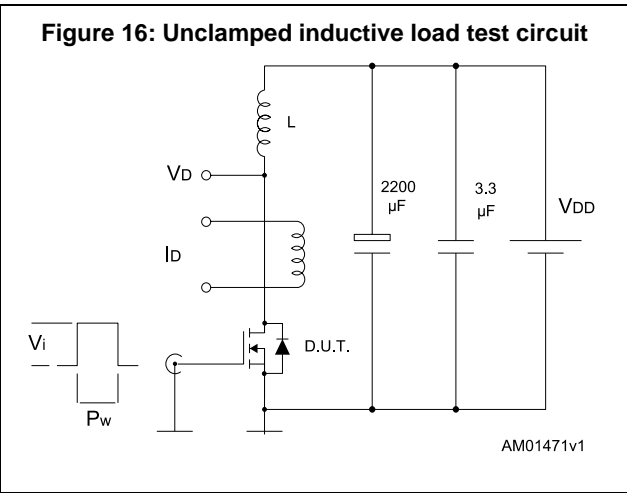
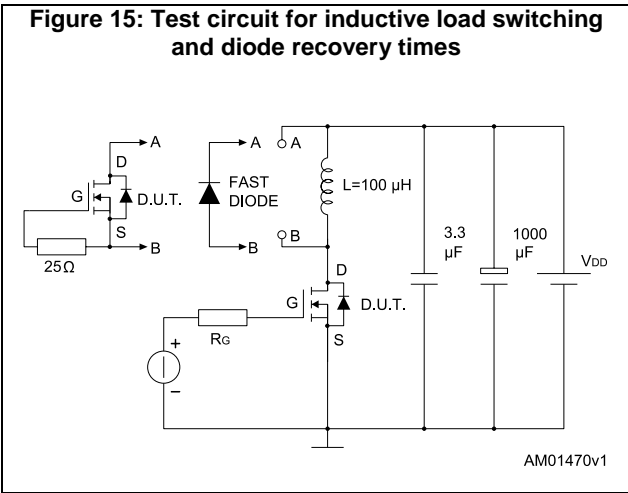
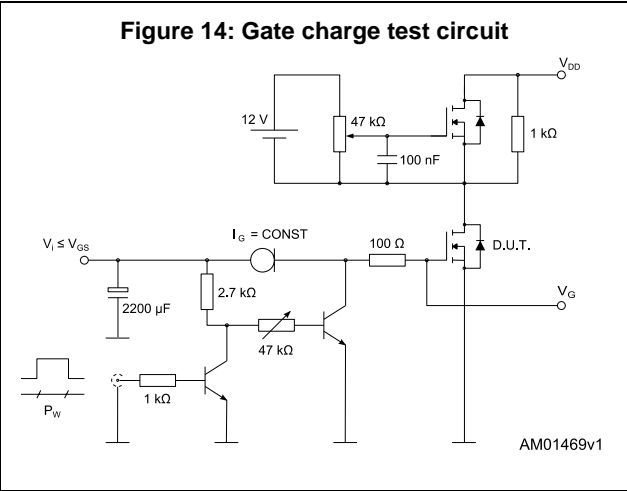
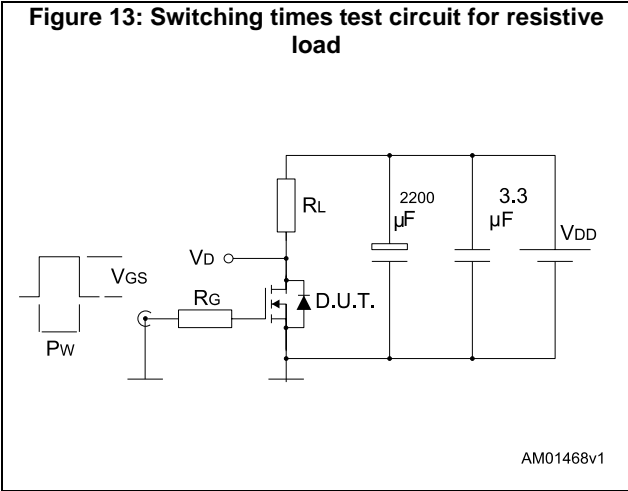

Figure 12: Source-drain diode forward characteristics



### 3 Test circuits



## 4 Package information

In order to meet environmental requirements, ST offers these devices in different grades of ECOPACK<sup>®</sup> packages, depending on their level of environmental compliance. ECOPACK<sup>®</sup> specifications, grade definitions and product status are available at: [www.st.com](http://www.st.com). ECOPACK<sup>®</sup> is an ST trademark.

### 4.1 TO-220 type A package information

Figure 19: TO-220 type A package outline

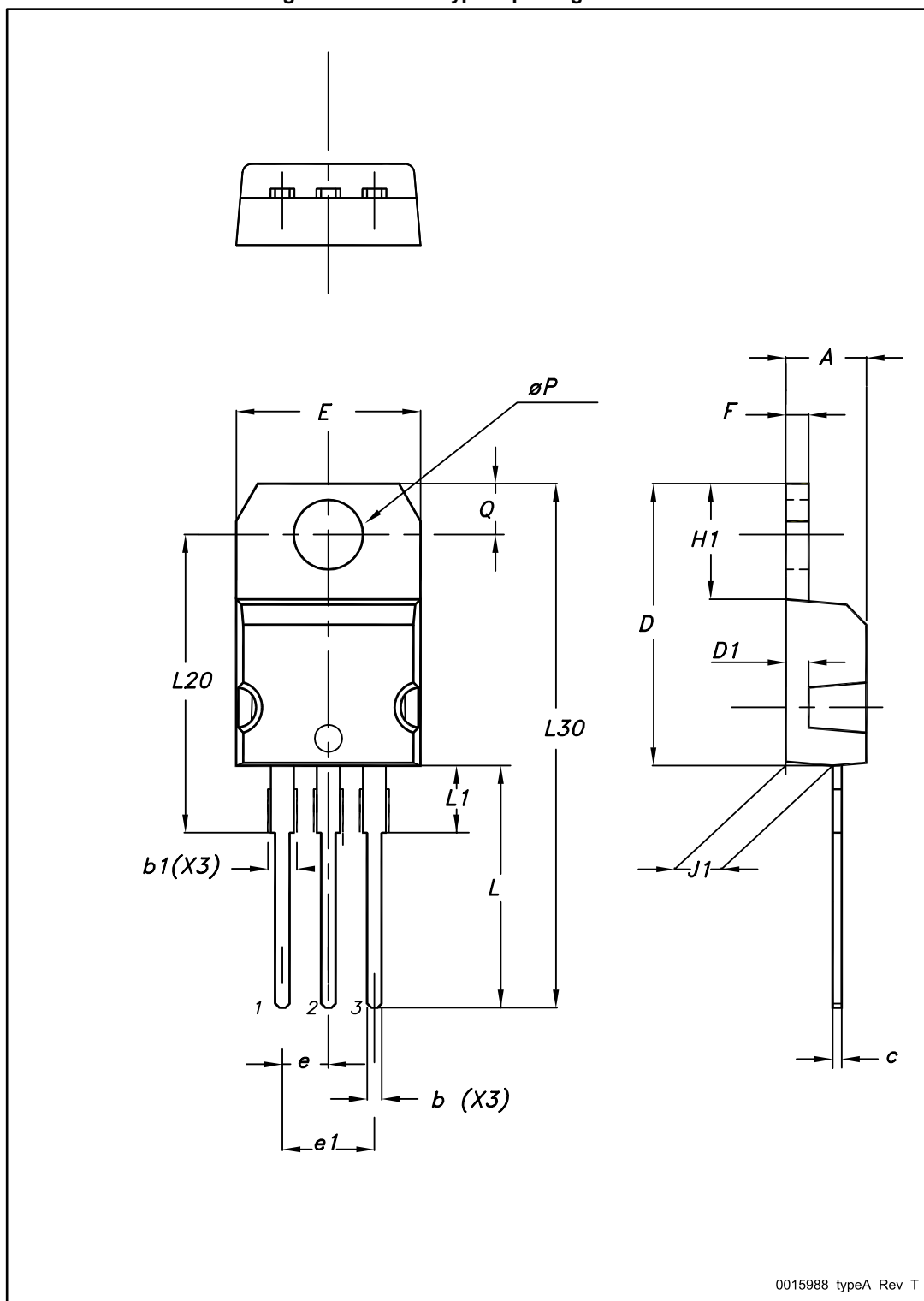

Table 8: TO-220 type A mechanical data

Dim.	mm		
	Min.	Typ.	Max.
A	4.40		4.60
b	0.61		0.88
b1	1.14		1.70
c	0.48		0.70
D	15.25		15.75
D1		1.27	
E	10		10.40
e	2.40		2.70
e1	4.95		5.15
F	1.23		1.32
H1	6.20		6.60
J1	2.40		2.72
L	13		14
L1	3.50		3.93
L20		16.40	
L30		28.90	
øP	3.75		3.85
Q	2.65		2.95

## 5 Revision history

**Table 9: Document revision history**

Date	Revision	Changes
31-Jul-2013	1	First release.
04-Jun-2015	2	Text edits and formatting changes throughout document In section 2 Electrical characteristics: - updated Table 4 Static - updated Table 5 Dynamic - updated Table 7 Source-drain diode - added Section 2.1 Electrical characteristics (curves) Updated and renamed Section 4 Package information (was Package mechanical data)
26-Jun-2015	3	On cover page: - updated Title and Description In Section Electrical ratings: - updated Table Absolute maximum ratings

**IMPORTANT NOTICE – PLEASE READ CAREFULLY**

STMicroelectronics NV and its subsidiaries ("ST") reserve the right to make changes, corrections, enhancements, modifications, and improvements to ST products and/or to this document at any time without notice. Purchasers should obtain the latest relevant information on ST products before placing orders. ST products are sold pursuant to ST's terms and conditions of sale in place at the time of order acknowledgement.

Purchasers are solely responsible for the choice, selection, and use of ST products and ST assumes no liability for application assistance or the design of Purchasers' products.

No license, express or implied, to any intellectual property right is granted by ST herein.

Resale of ST products with provisions different from the information set forth herein shall void any warranty granted by ST for such product.

ST and the ST logo are trademarks of ST. All other product or service names are the property of their respective owners.

Information in this document supersedes and replaces information previously supplied in any prior versions of this document.

© 2015 STMicroelectronics – All rights reserved