

## 800 mA fixed and adjustable output very low drop voltage regulator

Datasheet - production data

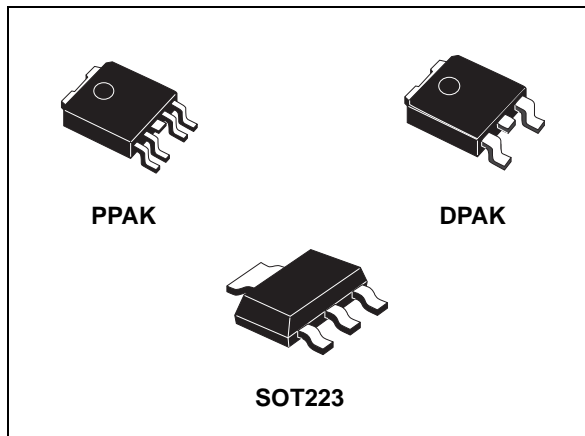

- Fixed and adjustable output voltage ( $\pm 1\%$  at 25 °C)
- Internal current and thermal limit
- Logic controlled electronic shutdown

### Description

The LD29080 is a medium current, high accuracy, low-dropout voltage regulators series. These regulators feature 400 mV dropout voltage and very low ground current. Designed for medium current loads, these devices also find applications in lower current, extremely low dropout-critical systems, where their tiny dropout voltage and ground current values are important attributes. Typical application are in power supply switching post regulation, series power supply for monitors, series power supply for VCRs and TVs, computer systems and battery powered systems.

### Features

- Very low dropout voltage (typ. 0.4 at 800 mA)
- Guaranteed output current up to 800 mA

Table 1. Device summary

Order codes			Output voltages
DPAK (tape and reel)	PPAK (tape and reel)	SOT223	
LD29080DT15R	LD29080PT15R		1.5 V
LD29080DT18R	LD29080PT18R		1.8 V
LD29080DT25R	LD29080PT25R		2.5 V
LD29080DT33R	LD29080PT33R	LD29080S33R	3.3 V
LD29080DT50R	LD29080PT50R		5.0 V
LD29080DT90R	LD29080PT90R		9.0 V
	LD29080PTR		ADJ

---

# Contents

1	Diagram .....	3
2	Pin configuration .....	4
3	Maximum ratings .....	5
4	Electrical characteristics .....	6
5	Typical characteristics .....	14
6	Package mechanical data .....	17
7	Packaging mechanical data .....	23
8	Revision history .....	25

# 1 Diagram

Figure 1. Schematic diagram for adjustable version

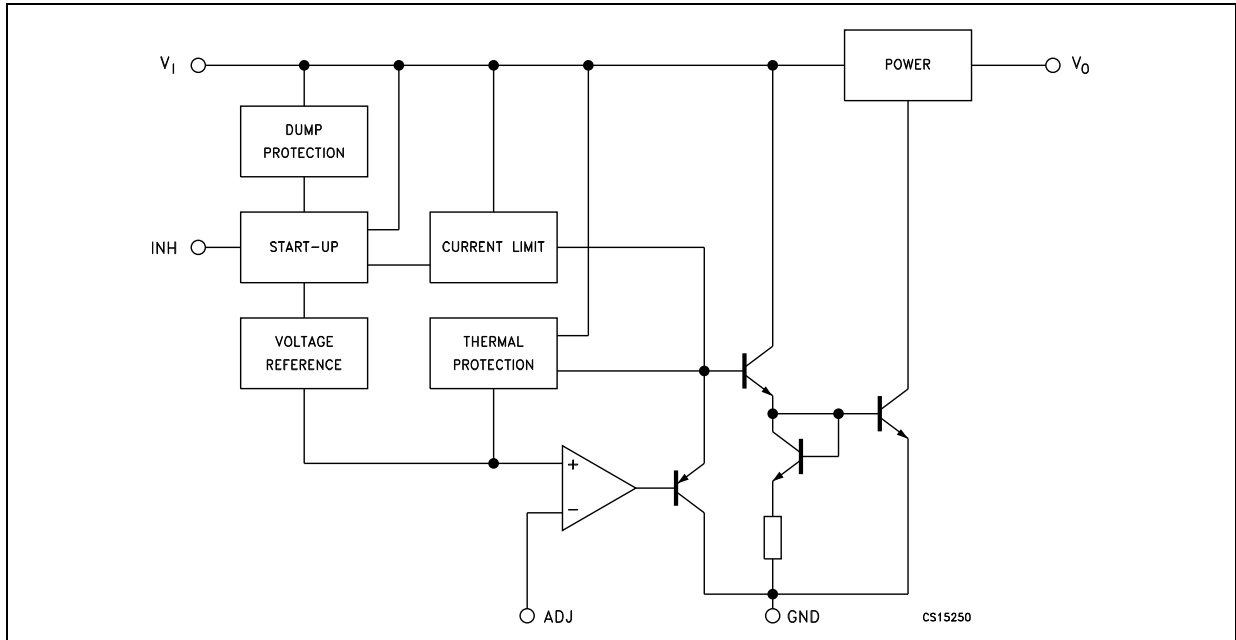
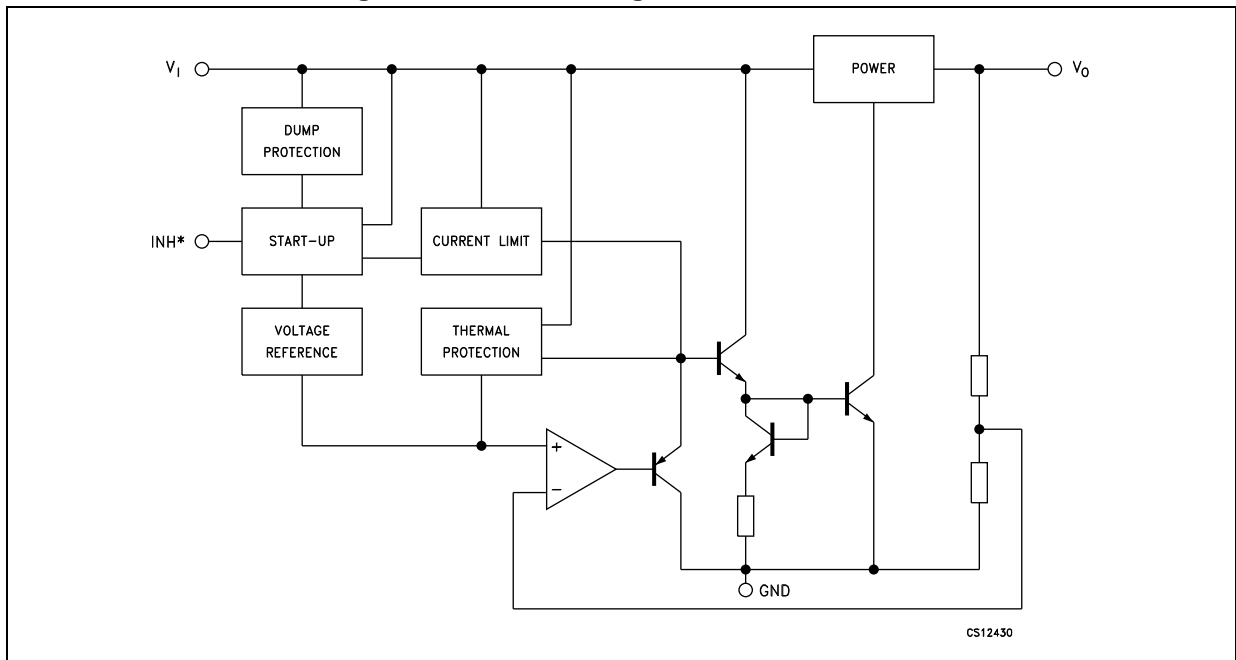

Figure 2. Schematic diagram for fixed version



\* Only for version with inhibit function.

## 2 Pin configuration

Figure 3. Pin connections (top view)

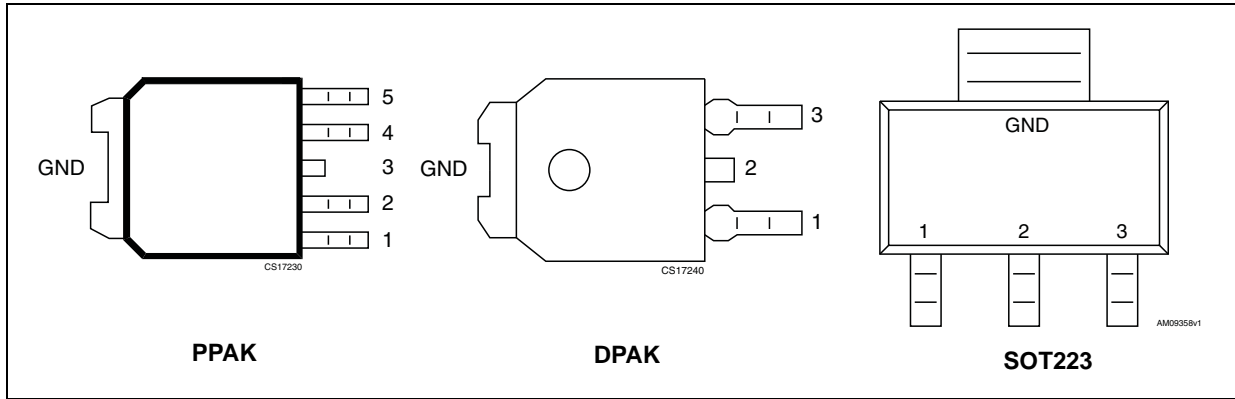
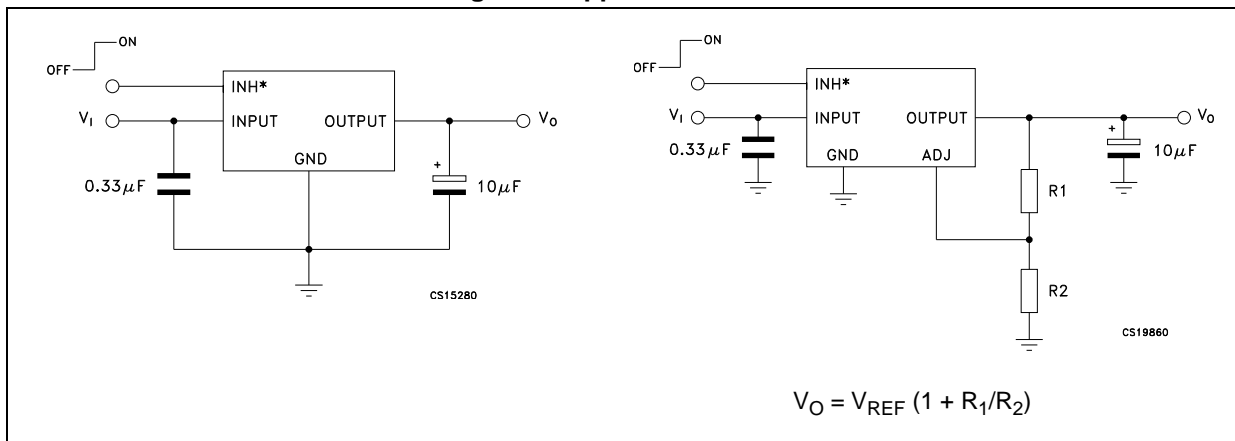

Table 2. Pin description

Symbol	PPAK	DPAK	SOT223
$V_I$	2	1	1
GND	3	2	2
$V_O$	4	3	3
ADJ/N.C. <sup>(1)</sup>	5		
INHIBIT <sup>(2)</sup>	1		

1. Not connected for fixed version.
2. Not internally pulled up; in order to assure the operating condition (device in ON mode), it must be connected to a positive voltage higher than 2 V.

Figure 4. Application circuit



\* Only for version with inhibit function.

### 3 Maximum ratings

**Table 3. Absolute maximum ratings**

Symbol	Parameter	Value	Unit
$V_I$	DC input voltage	30 <sup>(1)</sup>	V
$V_{INH}$	Inhibit input voltage	14	V
$I_O$	Output current	Internally limited	mA
$P_D$	Power dissipation	Internally limited	mW
$T_{STG}$	Storage temperature range	- 55 to 150	°C
$T_{OP}$	Operating temperature range	- 40 to 125	°C

1. Above 14 V the device is automatically in shut-down.

*Note: Absolute maximum ratings are those values beyond which damage to the device may occur. Functional operation under these conditions is not implied.*

**Table 4. Thermal data**

Symbol	Parameter	DPAK	PPAK	SOT223	Unit
$R_{thJC}$	Thermal resistance junction-case	8	8	25	°C/W
$R_{thJA}$	Thermal resistance junction-ambient	100	100	110	°C/W

## 4 Electrical characteristics

$I_O = 10 \text{ mA}$ , (*Note 4*)  $T_J = 25 \text{ }^\circ\text{C}$ ,  $V_I = 3.5 \text{ V}$ ,  $V_{INH} = 2\text{V}$ ,  $C_I = 330 \text{ nF}$ ,  $C_O = 10 \text{ }\mu\text{F}$ , unless otherwise specified.

**Table 5. Electrical characteristics of LD29080#15**

Symbol	Parameter	Test conditions	Min.	Typ.	Max.	Unit
$V_I$	Operating input voltage	$I_O = 10 \text{ mA}$ to $800 \text{ mA}$	2.5		13	V
$V_O$	Output voltage	$I_O = 10 \text{ mA}$ to $800 \text{ mA}$ , $V_I = 3$ to $7 \text{ V}$ $T_J = -40$ to $125 \text{ }^\circ\text{C}$	1.485	1.5	1.515	V
			1.463		1.537	
$\Delta V_O$	Load regulation	$I_O = 10 \text{ mA}$ to $800 \text{ mA}$		0.2	1.0	%
$\Delta V_O$	Line regulation	$V_I = 3$ to $13 \text{ V}$		0.06	0.5	%
SVR	Supply voltage rejection	$f = 120 \text{ Hz}$ , $V_I = 3.8 \pm 1 \text{ V}$ , $I_O = 400 \text{ mA}$ ( <i>Note 1</i> )	65	75		dB
$I_q$	Quiescent current	$I_O = 10 \text{ mA}$ , $T_J = -40$ to $125 \text{ }^\circ\text{C}$		2	5	mA
		$I_O = 400 \text{ mA}$ , $T_J = -40$ to $125 \text{ }^\circ\text{C}$		8	20	
		$I_O = 800 \text{ mA}$ , $T_J = -40$ to $125 \text{ }^\circ\text{C}$		14	35	
		$V_I = 13 \text{ V}$ , $V_{INH} = \text{GND}$ , $T_J = -40$ to $125 \text{ }^\circ\text{C}$		130	180	$\mu\text{A}$
$I_{sc}$	Short circuit current	$R_L = 0$		1.2		A
$V_{IL}$	Control input logic low	OFF MODE, $T_J = -40$ to $125 \text{ }^\circ\text{C}$			0.8	V
$V_{IH}$	Control input logic high	ON MODE, $T_J = -40$ to $125 \text{ }^\circ\text{C}$	2			V
$I_{INH}$	Control input current	$V_{INH} = 13\text{V}$ , $T_J = -40$ to $125 \text{ }^\circ\text{C}$		5	10	$\mu\text{A}$
eN	Output noise voltage	$B_P = 10 \text{ Hz}$ to $100 \text{ kHz}$ , $I_O = 100 \text{ mA}$ ( <i>Note 1</i> )		60		$\mu\text{V}_{\text{RMS}}$

- Note:
- 1 Guaranteed by design.
  - 2 Dropout voltage is defined as the input-to-output differential when the output voltage drops to 99% of its nominal value with  $V_O + 1 \text{ V}$  applied to  $V_I$ .
  - 3 Reference voltage is measured between output and GND pins, with ADJ PIN tied to  $V_O$ .
  - 4 In order to avoid any output voltage rise within the whole operating temperature range, due to output leakage current, a minimum load current of  $2 \text{ mA}$  is required.

$I_O = 10 \text{ mA}$ , (Note 4)  $T_J = 25 \text{ }^\circ\text{C}$ ,  $V_I = 3.5 \text{ V}$ ,  $V_{INH} = 2 \text{ V}$ ,  $C_I = 330 \text{ nF}$ ,  $C_O = 10 \text{ } \mu\text{F}$ , unless otherwise specified.

**Table 6. Electrical characteristics of LD29080#18**

Symbol	Parameter	Test conditions	Min.	Typ.	Max.	Unit
$V_I$	Operating input voltage	$I_O = 10 \text{ mA}$ to $800 \text{ mA}$	2.5		13	V
$V_O$	Output voltage	$I_O = 10 \text{ mA}$ to $800 \text{ mA}$ , $V_I = 3$ to $7.3 \text{ V}$ $T_J = -40$ to $125 \text{ }^\circ\text{C}$	1.782 1.755	1.8	1.818 1.845	V
$\Delta V_O$	Load regulation	$I_O = 10 \text{ mA}$ to $800 \text{ mA}$		0.2	1.0	%
$\Delta V_O$	Line regulation	$V_I = 3$ to $13 \text{ V}$		0.06	0.5	%
SVR	Supply voltage rejection	$f = 120 \text{ Hz}$ , $V_I = 3.8 \pm 1 \text{ V}$ , $I_O = 400 \text{ mA}$ (Note 1)	62	72		dB
$V_{DROP}$	Dropout voltage	$I_O = 150 \text{ mA}$ , $T_J = -40$ to $125 \text{ }^\circ\text{C}$ (Note 2) $I_O = 400 \text{ mA}$ , $T_J = -40$ to $125 \text{ }^\circ\text{C}$ (Note 2) $I_O = 800 \text{ mA}$ , $T_J = -40$ to $125 \text{ }^\circ\text{C}$ (Note 2)		0.1 0.2 0.4		V
$I_q$	Quiescent current	$I_O = 10 \text{ mA}$ , $T_J = -40$ to $125 \text{ }^\circ\text{C}$ $I_O = 400 \text{ mA}$ , $T_J = -40$ to $125 \text{ }^\circ\text{C}$ $I_O = 800 \text{ mA}$ , $T_J = -40$ to $125 \text{ }^\circ\text{C}$ $V_I = 13 \text{ V}$ , $V_{INH} = \text{GND}$ , $T_J = -40$ to $125 \text{ }^\circ\text{C}$		2 8 14 130	5 20 35 180	mA   $\mu\text{A}$
$I_{sc}$	Short circuit current	$R_L = 0$		1.2		A
$V_{IL}$	Control input logic low	OFF MODE, $T_J = -40$ to $125 \text{ }^\circ\text{C}$			0.8	V
$V_{IH}$	Control input logic high	ON MODE, $T_J = -40$ to $125 \text{ }^\circ\text{C}$	2			V
$I_{INH}$	Control input current	$V_{INH} = 13 \text{ V}$ , $T_J = -40$ to $125 \text{ }^\circ\text{C}$		5	10	$\mu\text{A}$
eN	Output noise voltage	$B_P = 10 \text{ Hz}$ to $100 \text{ kHz}$ , $I_O = 100 \text{ mA}$ (Note 1)		72		$\mu\text{V}_{RMS}$

Note: 1 Guaranteed by design.

2 Dropout voltage is defined as the input-to-output differential when the output voltage drops to 99% of its nominal value with  $V_O + 1 \text{ V}$  applied to  $V_I$ .

3 Reference voltage is measured between output and GND pins, with ADJ PIN tied to  $V_O$ .

4 In order to avoid any output voltage rise within the whole operating temperature range, due to output leakage current, a minimum load current of  $2 \text{ mA}$  is required.

$I_O = 10 \text{ mA}$ , (Note 4)  $T_J = 25 \text{ }^\circ\text{C}$ ,  $V_I = 4.5 \text{ V}$ ,  $V_{INH} = 2 \text{ V}$ ,  $C_I = 330 \text{ nF}$ ,  $C_O = 10 \text{ }\mu\text{F}$ , unless otherwise specified.

**Table 7. Electrical characteristics of LD29080#25**

Symbol	Parameter	Test conditions	Min.	Typ.	Max.	Unit
$V_I$	Operating input voltage	$I_O = 10 \text{ mA}$ to $800 \text{ mA}$			13	V
$V_O$	Output voltage	$I_O = 10 \text{ mA}$ to $800 \text{ mA}$ , $V_I = 3.5$ to $8 \text{ V}$ $T_J = -40$ to $125 \text{ }^\circ\text{C}$	2.475	2.5	2.525	V
			2.438		2.562	
$\Delta V_O$	Load regulation	$I_O = 10 \text{ mA}$ to $800 \text{ mA}$		0.2	1.0	%
$\Delta V_O$	Line regulation	$V_I = 3.5$ to $13 \text{ V}$		0.06	0.5	%
SVR	Supply voltage rejection	$f = 120 \text{ Hz}$ , $V_I = 4.5 \pm 1 \text{ V}$ , $I_O = 400 \text{ mA}$ (Note 1)	55	70		dB
$V_{DROP}$	Dropout voltage	$I_O = 150 \text{ mA}$ , $T_J = -40$ to $125 \text{ }^\circ\text{C}$ (Note 2)		0.1		V
		$I_O = 400 \text{ mA}$ , $T_J = -40$ to $125 \text{ }^\circ\text{C}$ (Note 2)		0.2		
		$I_O = 800 \text{ mA}$ , $T_J = -40$ to $125 \text{ }^\circ\text{C}$ (Note 2)		0.4	0.7	
$I_q$	Quiescent current	$I_O = 10 \text{ mA}$ , $T_J = -40$ to $125 \text{ }^\circ\text{C}$		2	5	mA
		$I_O = 400 \text{ mA}$ , $T_J = -40$ to $125 \text{ }^\circ\text{C}$		8	20	
		$I_O = 800 \text{ mA}$ , $T_J = -40$ to $125 \text{ }^\circ\text{C}$		14	35	
		$V_I = 13 \text{ V}$ , $V_{INH} = \text{GND}$ , $T_J = -40$ to $125 \text{ }^\circ\text{C}$		130	180	$\mu\text{A}$
$I_{sc}$	Short circuit current	$R_L = 0$		1.2		A
$V_{IL}$	Control input logic low	OFF MODE, $T_J = -40$ to $125 \text{ }^\circ\text{C}$			0.8	V
$V_{IH}$	Control input logic high	ON MODE, $T_J = -40$ to $125 \text{ }^\circ\text{C}$	2			V
$I_{INH}$	Control input current	$V_{INH} = 13 \text{ V}$ , $T_J = -40$ to $125 \text{ }^\circ\text{C}$		5	10	$\mu\text{A}$
eN	Output noise voltage	$B_p = 10 \text{ Hz}$ to $100 \text{ kHz}$ , $I_O = 100 \text{ mA}$ (Note 1)		100		$\mu\text{V}_{RMS}$

Note: 1 Guaranteed by design.

2 Dropout voltage is defined as the input-to-output differential when the output voltage drops to 99% of its nominal value with  $V_O + 1 \text{ V}$  applied to  $V_I$ .

3 Reference voltage is measured between output and GND pins, with ADJ PIN tied to  $V_O$ .

4 In order to avoid any output voltage rise within the whole operating temperature range, due to output leakage current, a minimum load current of  $2 \text{ mA}$  is required.

$I_O = 10 \text{ mA}$ , (Note 4)  $T_J = 25 \text{ }^\circ\text{C}$ ,  $V_I = 5.3 \text{ V}$ ,  $V_{INH} = 2 \text{ V}$ ,  $C_I = 330 \text{ nF}$ ,  $C_O = 10 \text{ }\mu\text{F}$ , unless otherwise specified.

**Table 8. Electrical characteristics of LD29080#33**

Symbol	Parameter	Test conditions	Min.	Typ.	Max.	Unit
$V_I$	Operating input voltage	$I_O = 10\text{mA to } 800\text{mA}$			13	V
$V_O$	Output voltage	$I_O = 10 \text{ mA to } 800 \text{ mA}$ , $V_I = 4.3 \text{ to } 8.8 \text{ V}$ $T_J = -40 \text{ to } 125 \text{ }^\circ\text{C}$	3.267 3.218	3.3	3.333 3.382	V
$\Delta V_O$	Load regulation	$I_O = 10 \text{ mA to } 800 \text{ mA}$		0.2	1.0	%
$\Delta V_O$	Line regulation	$V_I = 4.3 \text{ to } 13 \text{ V}$		0.06	0.5	%
SVR	Supply voltage rejection	$f = 120 \text{ Hz}$ , $V_I = 5.3 \pm 1 \text{ V}$ , $I_O = 400 \text{ mA}$ (Note 1)	52	67		dB
$V_{DROP}$	Dropout voltage	$I_O = 150 \text{ mA}$ , $T_J = -40 \text{ to } 125 \text{ }^\circ\text{C}$ (Note 2) $I_O = 400 \text{ mA}$ , $T_J = -40 \text{ to } 125 \text{ }^\circ\text{C}$ (Note 2) $I_O = 800 \text{ mA}$ , $T_J = -40 \text{ to } 125 \text{ }^\circ\text{C}$ (Note 2)		0.1 0.2 0.4		V
$I_q$	Quiescent current	$I_O = 10 \text{ mA}$ , $T_J = -40 \text{ to } 125 \text{ }^\circ\text{C}$ $I_O = 400 \text{ mA}$ , $T_J = -40 \text{ to } 125 \text{ }^\circ\text{C}$ $I_O = 800 \text{ mA}$ , $T_J = -40 \text{ to } 125 \text{ }^\circ\text{C}$ $V_I = 13 \text{ V}$ , $V_{INH} = \text{GND}$ , $T_J = -40 \text{ to } 125 \text{ }^\circ\text{C}$		2 8 14 130	5 20 35 180	mA   $\mu\text{A}$
$I_{sc}$	Short circuit current	$R_L = 0$		1.2		A
$V_{IL}$	Control input logic low	OFF MODE, $T_J = -40 \text{ to } 125 \text{ }^\circ\text{C}$			0.8	V
$V_{IH}$	Control input logic high	ON MODE, $T_J = -40 \text{ to } 125 \text{ }^\circ\text{C}$	2			V
$I_{INH}$	Control input current	$V_{INH} = 13 \text{ V}$ , $T_J = -40 \text{ to } 125 \text{ }^\circ\text{C}$		5	10	$\mu\text{A}$
eN	Output noise voltage	$B_P = 10 \text{ Hz to } 100 \text{ kHz}$ , $I_O = 100 \text{ mA}$ (Note 1)		132		$\mu\text{V}_{RMS}$

Note: 1 Guaranteed by design.

2 Dropout voltage is defined as the input-to-output differential when the output voltage drops to 99% of its nominal value with  $V_O + 1 \text{ V}$  applied to  $V_I$ .

3 Reference voltage is measured between output and GND pins, with ADJ PIN tied to  $V_O$ .

4 In order to avoid any output voltage rise within the whole operating temperature range, due to output leakage current, a minimum load current of 2 mA is required.

$I_O = 10 \text{ mA}$ , (Note 4)  $T_J = 25 \text{ }^\circ\text{C}$ ,  $V_I = 7 \text{ V}$ ,  $V_{INH} = 2 \text{ V}$ ,  $C_I = 330 \text{ nF}$ ,  $C_O = 10 \text{ } \mu\text{F}$ , unless otherwise specified.

**Table 9. Electrical characteristics of LD29080#50**

Symbol	Parameter	Test conditions	Min.	Typ.	Max.	Unit
$V_I$	Operating input voltage	$I_O = 10 \text{ mA}$ to $800 \text{ mA}$			13	V
$V_O$	Output voltage	$I_O = 10 \text{ mA}$ to $800 \text{ mA}$ , $V_I = 6$ to $10.5 \text{ V}$ $T_J = -40$ to $125 \text{ }^\circ\text{C}$	4.95 4.875	5	5.05 5.125	V
$\Delta V_O$	Load regulation	$I_O = 10 \text{ mA}$ to $800 \text{ mA}$		0.2	1.0	%
$\Delta V_O$	Line regulation	$V_I = 6$ to $13 \text{ V}$		0.06	0.5	%
SVR	Supply voltage rejection	$f = 120 \text{ Hz}$ , $V_I = 7 \pm 1 \text{ V}$ , $I_O = 400 \text{ mA}$ (Note 1)	49	64		dB
$V_{DROP}$	Dropout voltage	$I_O = 150 \text{ mA}$ , $T_J = -40$ to $125 \text{ }^\circ\text{C}$ (Note 2) $I_O = 400 \text{ mA}$ , $T_J = -40$ to $125 \text{ }^\circ\text{C}$ (Note 2) $I_O = 800 \text{ mA}$ , $T_J = -40$ to $125 \text{ }^\circ\text{C}$ (Note 2)		0.1 0.2 0.4		V
$I_q$	Quiescent current	$I_O = 10 \text{ mA}$ , $T_J = -40$ to $125 \text{ }^\circ\text{C}$ $I_O = 400 \text{ mA}$ , $T_J = -40$ to $125 \text{ }^\circ\text{C}$ $I_O = 800 \text{ mA}$ , $T_J = -40$ to $125 \text{ }^\circ\text{C}$ $V_I = 13 \text{ V}$ , $V_{INH} = \text{GND}$ , $T_J = -40$ to $125 \text{ }^\circ\text{C}$		2 8 14 130	5 20 35 180	mA   $\mu\text{A}$
$I_{sc}$	Short circuit current	$R_L = 0$		1.2		A
$V_{IL}$	Control input logic low	OFF MODE, $T_J = -40$ to $125 \text{ }^\circ\text{C}$			0.8	V
$V_{IH}$	Control input logic high	ON MODE, $T_J = -40$ to $125 \text{ }^\circ\text{C}$	2			V
$I_{INH}$	Control input current	$V_{INH} = 13 \text{ V}$ , $T_J = -40$ to $125 \text{ }^\circ\text{C}$		5	10	$\mu\text{A}$
eN	Output noise voltage	$B_P = 10 \text{ Hz}$ to $100 \text{ kHz}$ , $I_O = 100 \text{ mA}$ (Note 1)		180		$\mu\text{V}_{RMS}$

Note: 1 Guaranteed by design.

2 Dropout voltage is defined as the input-to-output differential when the output voltage drops to 99% of its nominal value with  $V_O + 1 \text{ V}$  applied to  $V_I$ .

3 Reference voltage is measured between output and GND pins, with ADJ PIN tied to  $V_O$ .

4 In order to avoid any output voltage rise within the whole operating temperature range, due to output leakage current, a minimum load current of  $2 \text{ mA}$  is required.

$I_O = 10 \text{ mA}$ , (Note 4)  $T_J = 25 \text{ }^\circ\text{C}$ ,  $V_I = 10 \text{ V}$ ,  $V_{INH} = 2 \text{ V}$ ,  $C_I = 330 \text{ nF}$ ,  $C_O = 10 \text{ } \mu\text{F}$ , unless otherwise specified)

**Table 10. Electrical characteristics of LD29080#80**

Symbol	Parameter	Test conditions	Min.	Typ.	Max.	Unit
$V_I$	Operating input voltage	$I_O = 10 \text{ mA}$ to $800 \text{ mA}$			13	V
$V_O$	Output voltage	$I_O = 10 \text{ mA}$ to $800 \text{ mA}$ , $V_I = 9$ to $13 \text{ V}$ $T_J = -40$ to $125 \text{ }^\circ\text{C}$	7.92 7.80	8	8.08 8.20	V
$\Delta V_O$	Load regulation	$I_O = 10 \text{ mA}$ to $800 \text{ mA}$		0.2	1.0	%
$\Delta V_O$	Line regulation	$V_I = 9$ to $13 \text{ V}$		0.06	0.5	%
SVR	Supply voltage rejection	$f = 120 \text{ Hz}$ , $V_I = 10 \pm 1 \text{ V}$ , $I_O = 400 \text{ mA}$ (Note 1)	45	59		dB
$V_{DROP}$	Dropout voltage	$I_O = 150 \text{ mA}$ , $T_J = -40$ to $125 \text{ }^\circ\text{C}$ (Note 2) $I_O = 400 \text{ mA}$ , $T_J = -40$ to $125 \text{ }^\circ\text{C}$ (Note 2) $I_O = 800 \text{ mA}$ , $T_J = -40$ to $125 \text{ }^\circ\text{C}$ (Note 2)		0.1 0.2 0.4		V
$I_q$	Quiescent current	$I_O = 10 \text{ mA}$ , $T_J = -40$ to $125 \text{ }^\circ\text{C}$ $I_O = 400 \text{ mA}$ , $T_J = -40$ to $125 \text{ }^\circ\text{C}$ $I_O = 800 \text{ mA}$ , $T_J = -40$ to $125 \text{ }^\circ\text{C}$ $V_I = 13 \text{ V}$ , $V_{INH} = \text{GND}$ , $T_J = -40$ to $125 \text{ }^\circ\text{C}$		2 8 14 130	5 20 35 180	mA   $\mu\text{A}$
$I_{sc}$	Short circuit current	$R_L = 0$		1.2		A
$V_{IL}$	Control input logic low	OFF MODE, $T_J = -40$ to $125 \text{ }^\circ\text{C}$			0.8	V
$V_{IH}$	Control input logic high	ON MODE, $T_J = -40$ to $125 \text{ }^\circ\text{C}$	2			V
$I_{INH}$	Control input current	$V_{INH} = 13 \text{ V}$ , $T_J = -40$ to $125 \text{ }^\circ\text{C}$		5	10	$\mu\text{A}$
eN	Output noise voltage	$B_P = 10 \text{ Hz}$ to $100 \text{ kHz}$ , $I_O = 100 \text{ mA}$ (Note 1)		320		$\mu\text{V}_{RMS}$

Note: 1 Guaranteed by design.

2 Dropout voltage is defined as the input-to-output differential when the output voltage drops to 99% of its nominal value with  $V_O + 1 \text{ V}$  applied to  $V_I$ .

3 Reference voltage is measured between output and GND pins, with ADJ PIN tied to  $V_O$ .

4 In order to avoid any output voltage rise within the whole operating temperature range, due to output leakage current, a minimum load current of  $2 \text{ mA}$  is required.

$I_O = 10 \text{ mA}$ , (Note 4)  $T_J = 25 \text{ }^\circ\text{C}$ ,  $V_I = 11 \text{ V}$ ,  $V_{INH} = 2 \text{ V}$ ,  $C_I = 330 \text{ nF}$ ,  $C_O = 10 \text{ }\mu\text{F}$ , unless otherwise specified.

Table 11. Electrical characteristics of LD29080#90

Symbol	Parameter	Test conditions	Min.	Typ.	Max.	Unit
$V_I$	Operating input voltage	$I_O = 10 \text{ mA}$ to $800 \text{ mA}$			13	V
$V_O$	Output voltage	$I_O = 10 \text{ mA}$ to $800 \text{ mA}$ , $V_I = 9$ to $13 \text{ V}$ $T_J = -40$ to $125 \text{ }^\circ\text{C}$	8.91 8.775	9	9.09 9.225	V
$\Delta V_O$	Load regulation	$I_O = 10 \text{ mA}$ to $800 \text{ mA}$		0.2	1.0	%
$\Delta V_O$	Line regulation	$V_I = 10$ to $13 \text{ V}$		0.06	0.5	%
SVR	Supply voltage rejection	$f = 120 \text{ Hz}$ , $V_I = 11 \pm 1 \text{ V}$ , $I_O = 400 \text{ mA}$ (Note 1)	43	57		dB
$V_{DROP}$	Dropout voltage	$I_O = 150 \text{ mA}$ , $T_J = -40$ to $125 \text{ }^\circ\text{C}$ (Note 2) $I_O = 400 \text{ mA}$ , $T_J = -40$ to $125 \text{ }^\circ\text{C}$ (Note 2) $I_O = 800 \text{ mA}$ , $T_J = -40$ to $125 \text{ }^\circ\text{C}$ (Note 2)		0.1 0.2 0.4		V
$I_q$	Quiescent current	$I_O = 10 \text{ mA}$ , $T_J = -40$ to $125 \text{ }^\circ\text{C}$ $I_O = 400 \text{ mA}$ , $T_J = -40$ to $125 \text{ }^\circ\text{C}$ $I_O = 800 \text{ mA}$ , $T_J = -40$ to $125 \text{ }^\circ\text{C}$ $V_I = 13 \text{ V}$ , $V_{INH} = \text{GND}$ , $T_J = -40$ to $125 \text{ }^\circ\text{C}$		2 8 14 130	5 20 35 180	mA   $\mu\text{A}$
$I_{sc}$	Short circuit current	$R_L = 0$		1.2		A
$V_{IL}$	Control input logic low	OFF MODE, $T_J = -40$ to $125 \text{ }^\circ\text{C}$			0.8	V
$V_{IH}$	Control input logic high	ON MODE, $T_J = -40$ to $125 \text{ }^\circ\text{C}$	2			V
$I_{INH}$	Control input current	$V_{INH} = 13 \text{ V}$ , $T_J = -40$ to $125 \text{ }^\circ\text{C}$		5	10	$\mu\text{A}$
eN	Output noise voltage	$B_P = 10 \text{ Hz}$ to $100 \text{ kHz}$ , $I_O = 100 \text{ mA}$ (Note 1)		330		$\mu\text{V}_{RMS}$

Note: 1 Guaranteed by design.

2 Dropout voltage is defined as the input-to-output differential when the output voltage drops to 99% of its nominal value with  $V_O + 1 \text{ V}$  applied to  $V_I$ .

3 Reference voltage is measured between output and GND pins, with ADJ PIN tied to  $V_O$ .

4 In order to avoid any output voltage rise within the whole operating temperature range, due to output leakage current, a minimum load current of  $2 \text{ mA}$  is required.

$I_O = 10 \text{ mA}$ , (Note 4)  $T_J = 25 \text{ }^\circ\text{C}$ ,  $V_I = 10 \text{ V}$ ,  $V_{INH} = 2 \text{ V}$ ,  $C_I = 330 \text{ nF}$ ,  $C_O = 10 \text{ } \mu\text{F}$ , unless otherwise specified.

**Table 12. Electrical characteristics of LD29080#ADJ**

Symbol	Parameter	Test conditions	Min.	Typ.	Max.	Unit
$V_I$	Operating input voltage	$I_O = 10 \text{ mA}$ to $800 \text{ mA}$	2.5		13	V
$\Delta V_O$	Load regulation	$I_O = 10 \text{ mA}$ to $800 \text{ mA}$		0.2	1.0	%
$\Delta V_O$	Line regulation	$V_I = 2.5$ to $13 \text{ V}$ , $I_O = 10 \text{ mA}$		0.06	0.5	%
$V_{REF}$	Reference voltage	$I_O = 10 \text{ mA}$ to $800 \text{ mA}$ , $V_I = 2.5$ to $6.73 \text{ V}$ $T_J = -40$ to $125 \text{ }^\circ\text{C}$ (Note 3)	1.2177	1.23	1.2423	V
			1.1993		1.2607	
SVR	Supply voltage rejection	$f = 120 \text{ Hz}$ , $V_I = 3.23 \pm 1 \text{ V}$ , $I_O = 400 \text{ mA}$ (Note 1)	45	75		dB
$I_q$	Quiescent current	$I_O = 10 \text{ mA}$ , $T_J = -40$ to $125 \text{ }^\circ\text{C}$		2	5	mA
		$I_O = 400 \text{ mA}$ , $T_J = -40$ to $125 \text{ }^\circ\text{C}$		8	20	
		$I_O = 800 \text{ mA}$ , $T_J = -40$ to $125 \text{ }^\circ\text{C}$		14	35	
		$V_I = 13 \text{ V}$ , $V_{INH} = \text{GND}$ , $T_J = -40$ to $125 \text{ }^\circ\text{C}$		130	180	$\mu\text{A}$
$I_{ADJ}$	Adjust pin current	$T_J = -40$ to $125 \text{ }^\circ\text{C}$			1	$\mu\text{A}$
$I_{sc}$	Short circuit current	$R_L = 0$		1.2		A
$V_{IL}$	Control input logic low	OFF MODE, $T_J = -40$ to $125 \text{ }^\circ\text{C}$			0.8	V
$V_{IH}$	Control input logic high	ON MODE, $T_J = -40$ to $125 \text{ }^\circ\text{C}$	2			V
$I_{INH}$	Control input current	$V_{INH} = 13 \text{ V}$ , $T_J = -40$ to $125 \text{ }^\circ\text{C}$		5	10	$\mu\text{A}$
eN	Output noise voltage	$B_P = 10 \text{ Hz}$ to $100 \text{ kHz}$ , $I_O = 100 \text{ mA}$ (Note 1)		50		$\mu\text{V}_{RMS}$

Note: 1 Guaranteed by design.

2 Dropout voltage is defined as the input-to-output differential when the output voltage drops to 99% of its nominal value with  $V_O + 1 \text{ V}$  applied to  $V_I$ .

3 Reference voltage is measured between output and GND pins, with ADJ PIN tied to  $V_O$ .

4 In order to avoid any output voltage rise within the whole operating temperature range, due to output leakage current, a minimum load current of  $2 \text{ mA}$  is required.

## 5 Typical characteristics

Figure 5. Output voltage vs. temperature

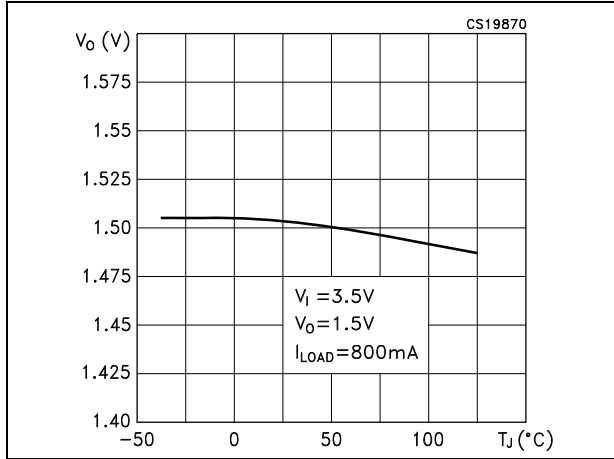

Figure 6. Reference voltage vs. temperature

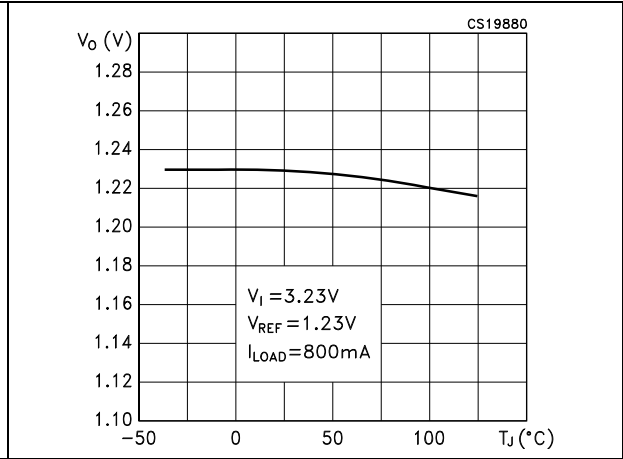

Figure 7. Dropout voltage vs. temperature

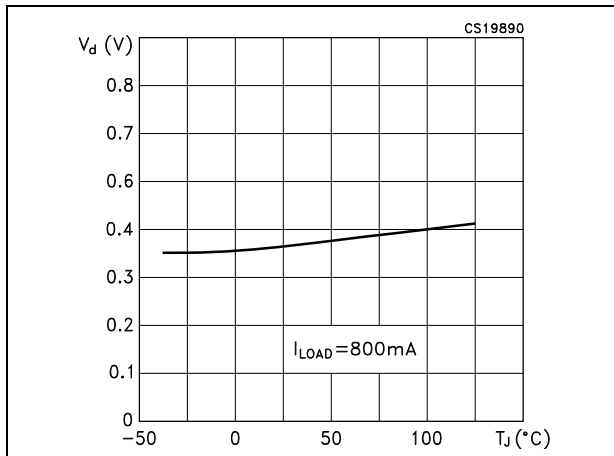

Figure 8. Dropout voltage vs. output current

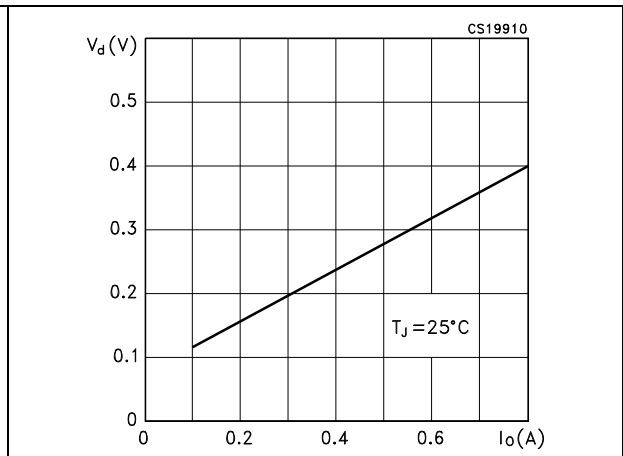

Figure 9. Quiescent current vs. output current

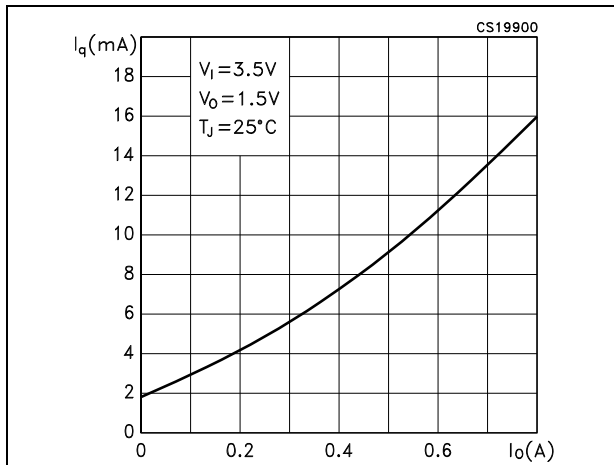

Figure 10. Quiescent current vs. temperature (I<sub>o</sub> = 10 mA)

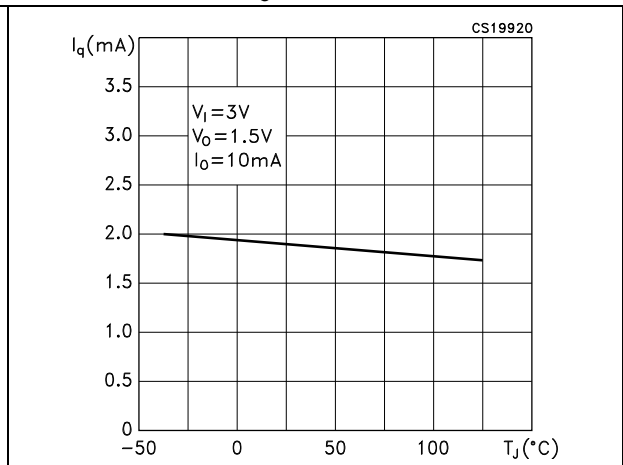

Figure 11. Quiescent current vs. supply voltage      Figure 12. Quiescent current vs. temperature ( $I_o = 800 \text{ mA}$ )

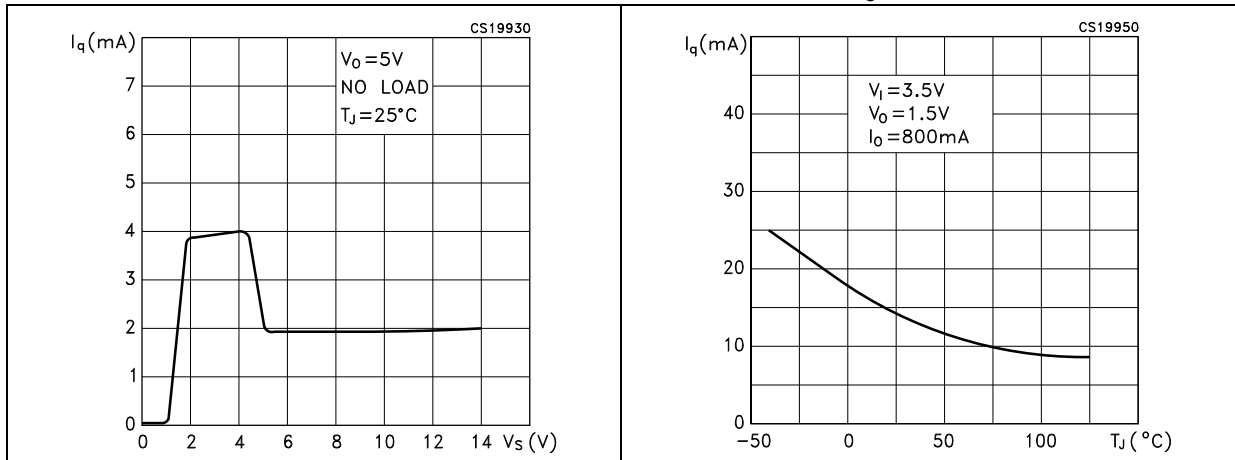

Figure 13. Short circuit current vs. temperature      Figure 14. Adjust pin current vs. temperature

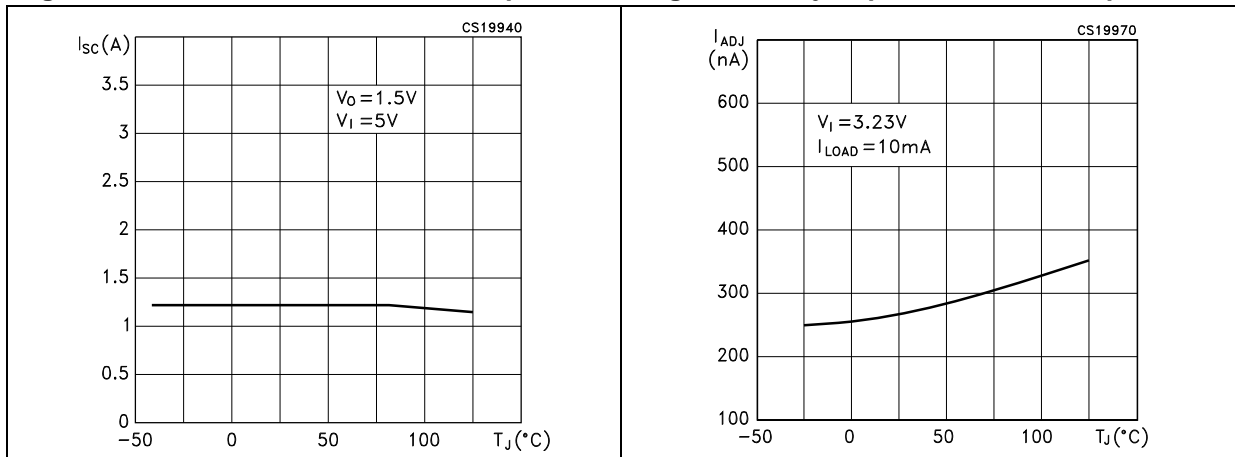

Figure 15. Supply voltage rejection vs. temperature      Figure 16. Output voltage vs. input voltage

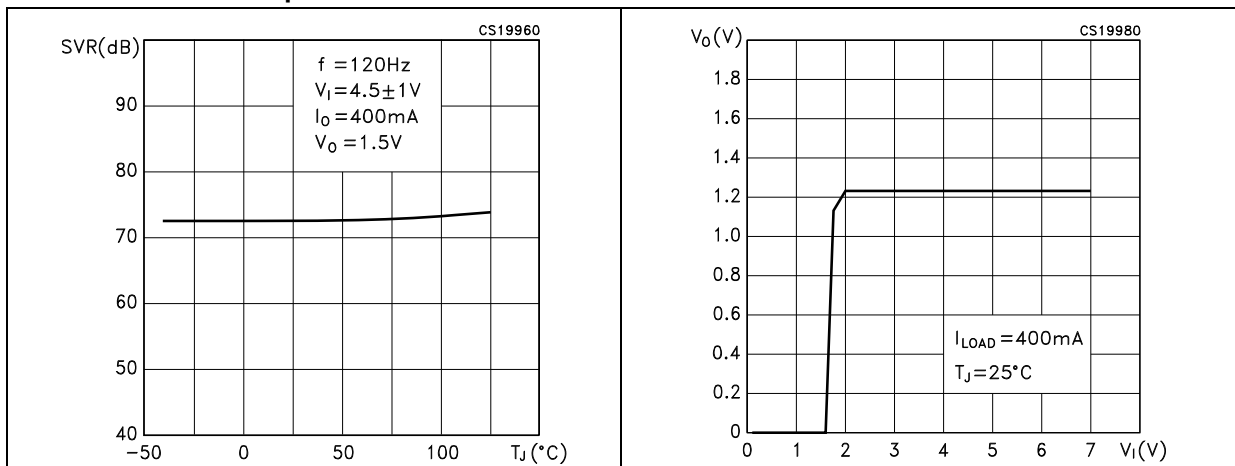

Figure 17. Stability vs.  $C_O$

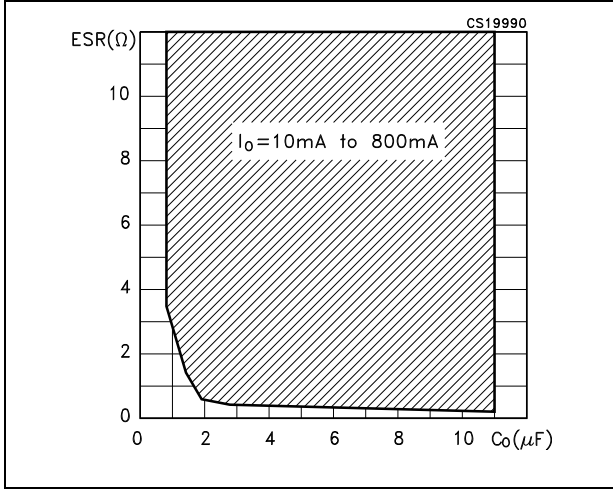

Figure 18. Line transient

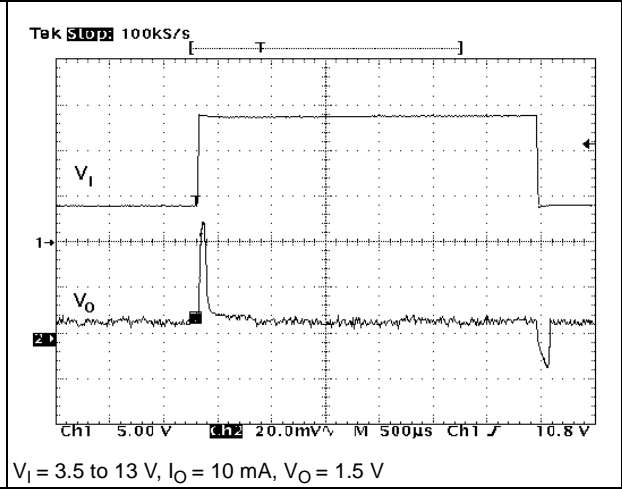
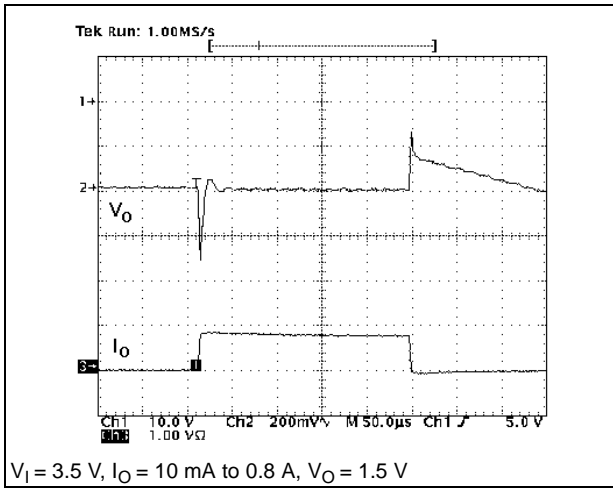

Figure 19. Load transient



## 6 Package mechanical data

In order to meet environmental requirements, ST offers these devices in different grades of ECOPACK<sup>®</sup> packages, depending on their level of environmental compliance. ECOPACK<sup>®</sup> specifications, grade definitions and product status are available at: [www.st.com](http://www.st.com). ECOPACK<sup>®</sup> is an ST trademark.

**Table 13. PPAK mechanical data**

Dim.	mm		
	Min.	Typ.	Max.
A	2.2		2.4
A1	0.9		1.1
A2	0.03		0.23
B	0.4		0.6
B2	5.2		5.4
C	0.45		0.6
C2	0.48		0.6
D	6		6.2
D1		5.1	
E	6.4		6.6
E1		4.7	
e		1.27	
G	4.9		5.25
G1	2.38		2.7
H	9.35		10.1
L2		0.8	1
L4	0.6		1
L5	1		
L6		2.8	
R		0.20	
V2	0°		8°

Figure 20. PPAK drawing

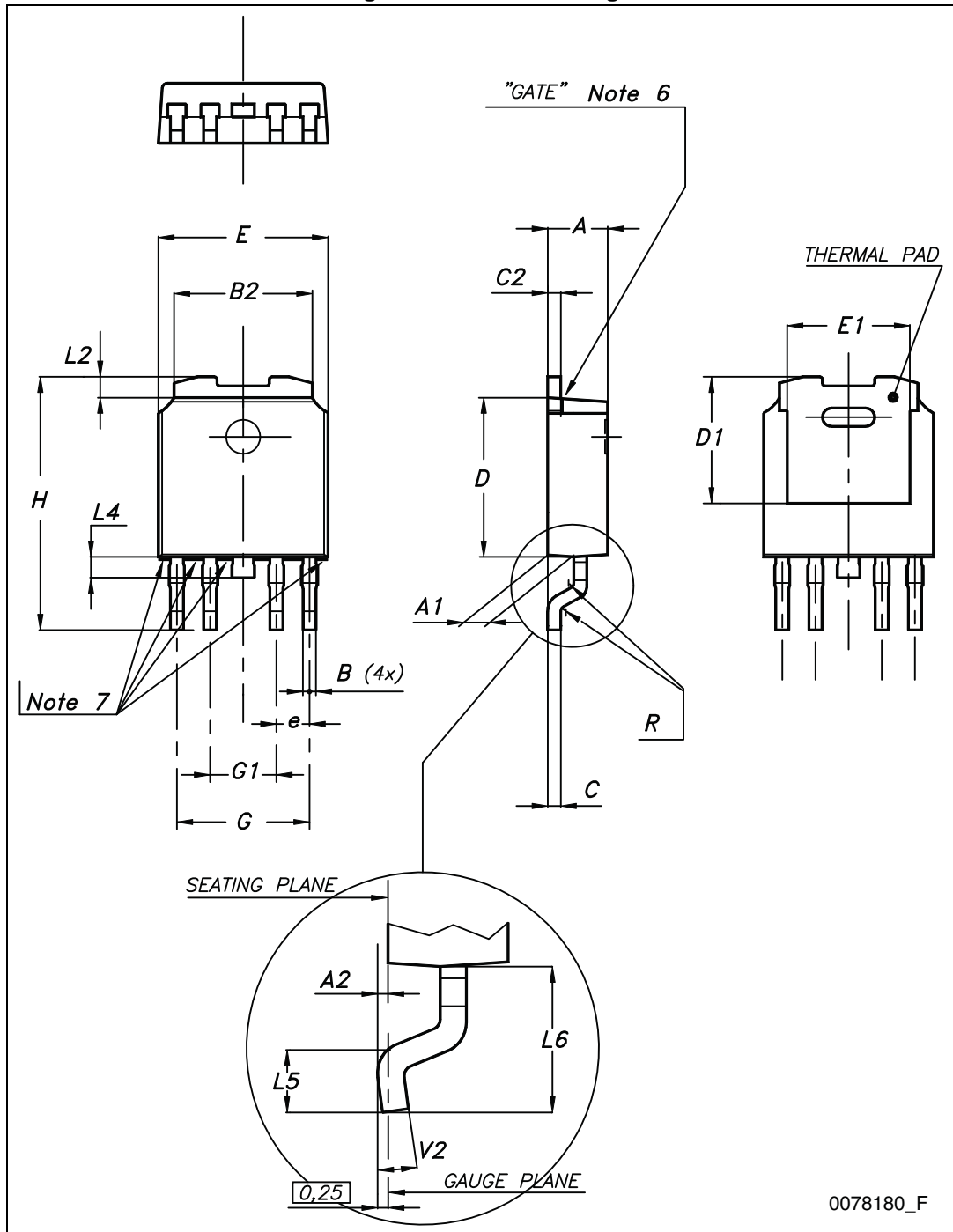
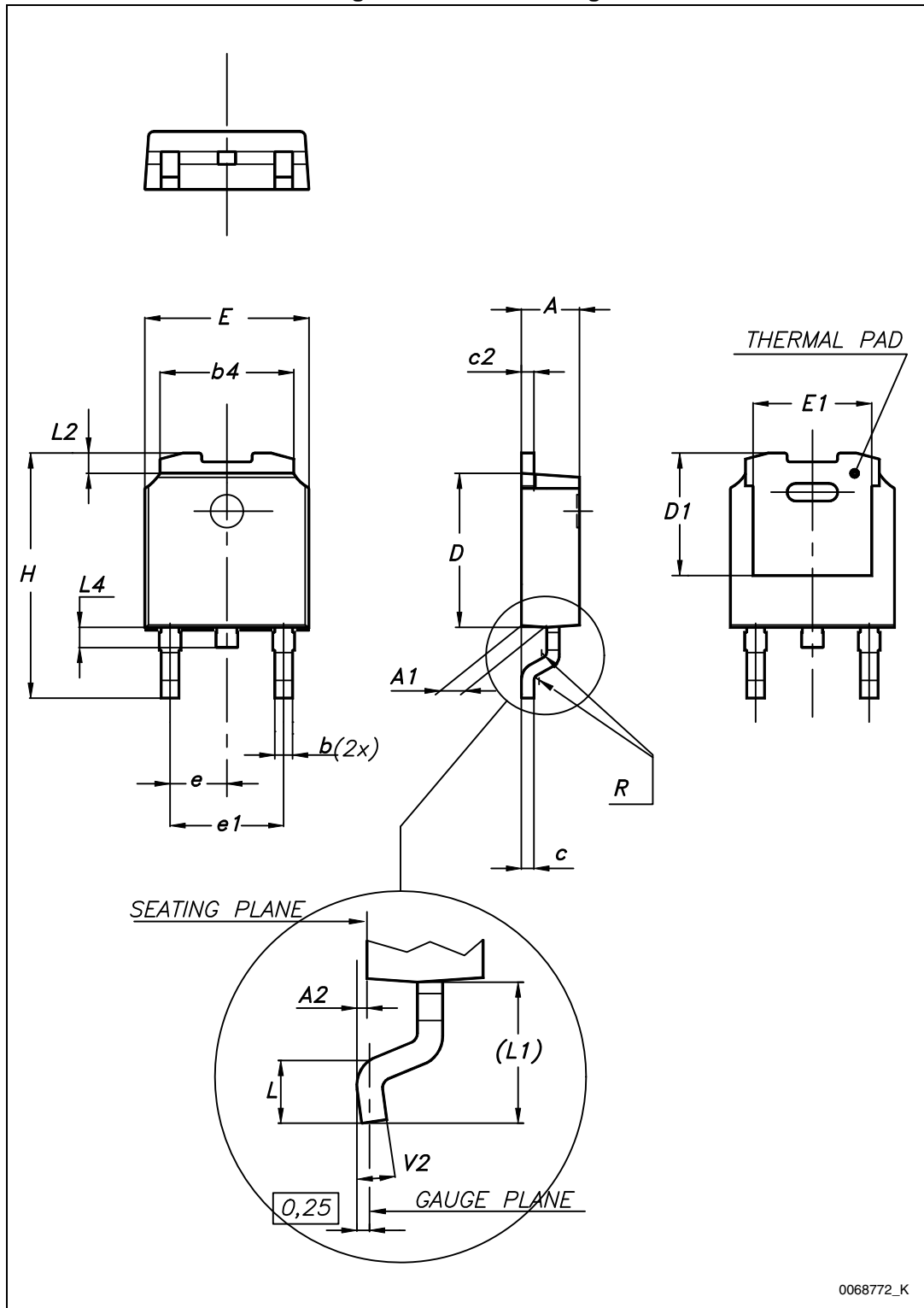

Table 14. DPAK mechanical data

Dim.	mm		
	Min.	Typ.	Max.
A	2.20		2.40
A1	0.90		1.10
A2	0.03		0.23
b	0.64		0.90
b4	5.20		5.40
c	0.45		0.60
c2	0.48		0.60
D	6.00		6.20
D1		5.10	
E	6.40		6.60
E1		4.70	
e		2.28	
e1	4.40		4.60
H	9.35		10.10
L	1.00		1.50
(L1)		2.80	
L2		0.80	
L4	0.60		1.00
R		0.20	
V2	0°		8°

Figure 21. DPAK drawing



0068772\_K

Figure 22. DPAK footprint (a)

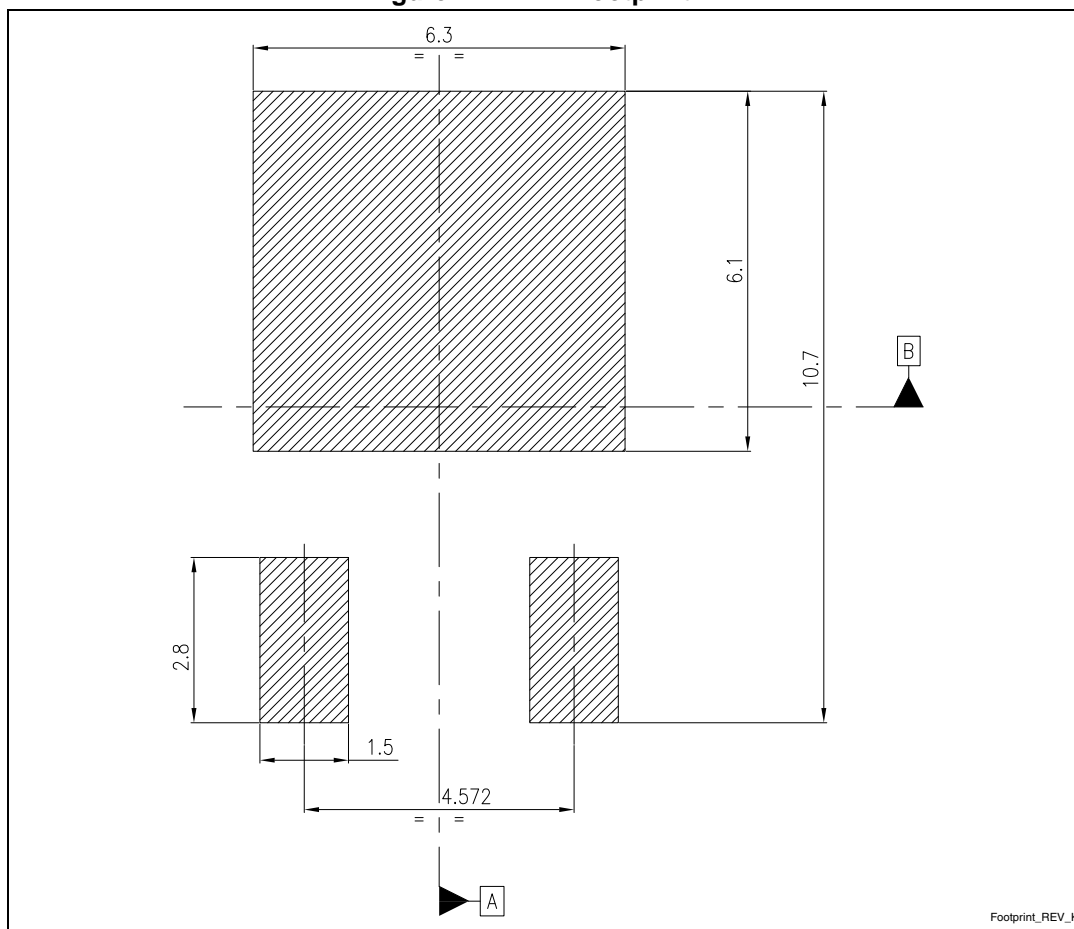

a. All dimensions are in millimeters

Table 15. SOT-223 mechanical data

Dim.	mm		
	Min.	Typ.	Max.
A			1.80
A1	0.02		0.1
B	0.60	0.70	0.85
B1	2.90	3.00	3.15
c	0.24	0.26	0.35
D	6.30	6.50	6.70
e		2.30	
e1		4.60	
E	3.30	3.50	3.70
H	6.70	7.00	7.30
V			10°

Figure 23. SOT-223 mechanical data drawing

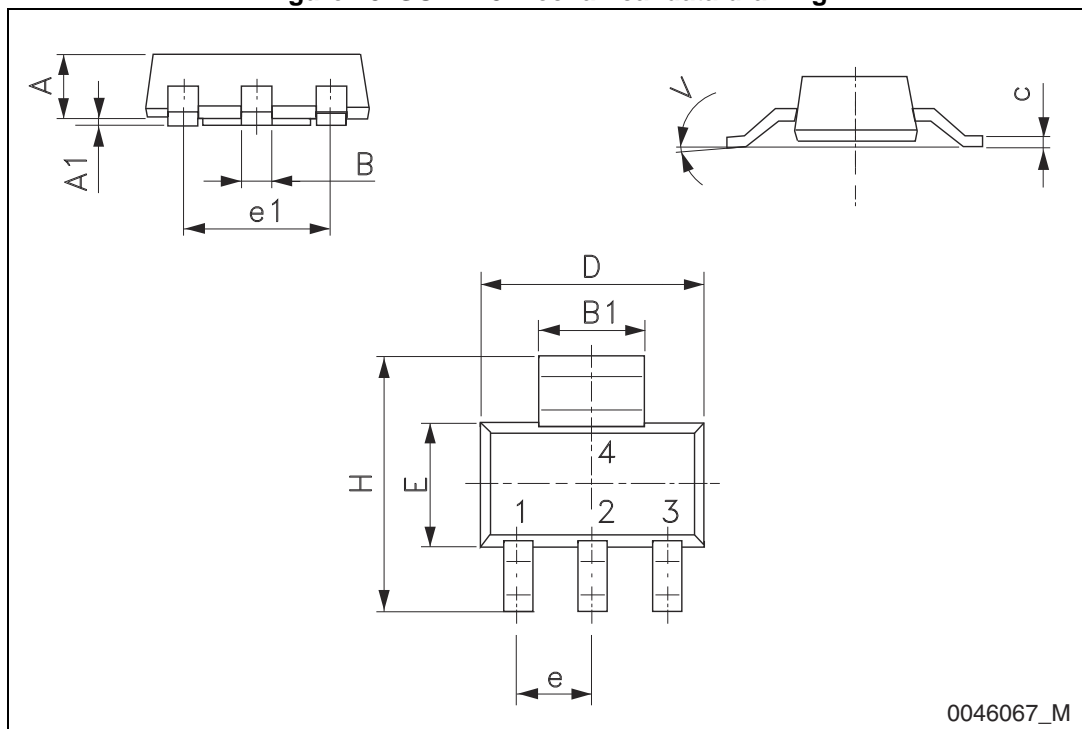

0046067\_M

## 7 Packaging mechanical data

Table 16. PPAK and DPAK tape and reel mechanical data

Tape			Reel		
Dim.	mm		Dim.	mm	
	Min.	Max.		Min.	Max.
A0	6.8	7	A		330
B0	10.4	10.6	B	1.5	
B1		12.1	C	12.8	13.2
D	1.5	1.6	D	20.2	
D1	1.5		G	16.4	18.4
E	1.65	1.85	N	50	
F	7.4	7.6	T		22.4
K0	2.55	2.75			
P0	3.9	4.1	Base qty.		2500
P1	7.9	8.1	Bulk qty.		2500
P2	1.9	2.1			
R	40				
T	0.25	0.35			
W	15.7	16.3			

Figure 24. Tape for PPAK and DPAK

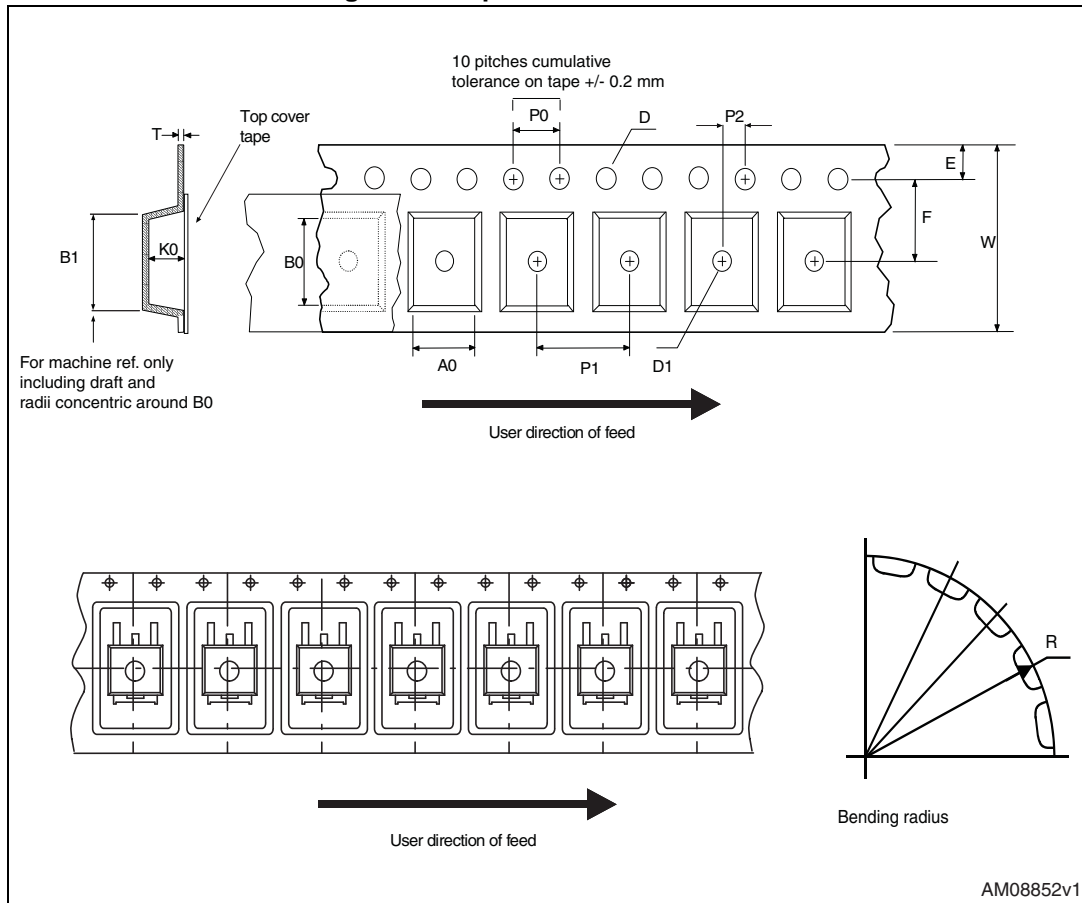
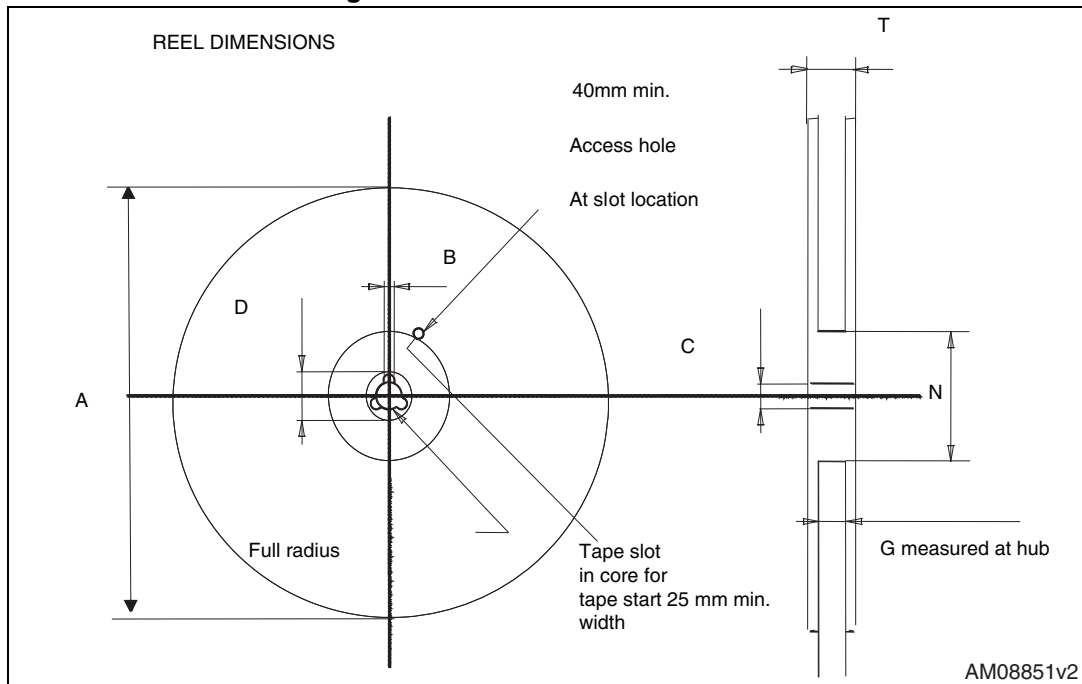

Figure 25. Reel for PPAK and DPAK



## 8 Revision history

**Table 17. Document revision history**

Date	Revision	Changes
15-Oct-2004	1	First release.
20-Oct-2005	2	Order codes updated.
14-May-2007	3	Order codes updated.
26-Jan-2009	4	Modified: eN value in <a href="#">Table 9 on page 10</a> .
22-Feb-2011	5	Added: new order code <a href="#">Table 1 on page 1</a> and mechanical data.
12-Jan-2012	6	Modified: $R_{thJA}$ and $R_{thJC}$ value for SOT223 <a href="#">Table 4 on page 5</a> .
08-May-2012	7	Modified: pin connections for PPAK, DPAK and SOT223 <a href="#">Figure 3 on page 4</a> .
22-Nov-2013	8	Part number LD29080xx changed to LD29080. Updated the Description in cover page, <a href="#">Table 1: Device summary</a> . Updated <a href="#">Section 5: Typical characteristics</a> and <a href="#">Section 6: Package mechanical data</a> . Added <a href="#">Section 7: Packaging mechanical data</a> . Minor text changes.

**Please Read Carefully:**

Information in this document is provided solely in connection with ST products. STMicroelectronics NV and its subsidiaries ("ST") reserve the right to make changes, corrections, modifications or improvements, to this document, and the products and services described herein at any time, without notice.

All ST products are sold pursuant to ST's terms and conditions of sale.

Purchasers are solely responsible for the choice, selection and use of the ST products and services described herein, and ST assumes no liability whatsoever relating to the choice, selection or use of the ST products and services described herein.

No license, express or implied, by estoppel or otherwise, to any intellectual property rights is granted under this document. If any part of this document refers to any third party products or services it shall not be deemed a license grant by ST for the use of such third party products or services, or any intellectual property contained therein or considered as a warranty covering the use in any manner whatsoever of such third party products or services or any intellectual property contained therein.

**UNLESS OTHERWISE SET FORTH IN ST'S TERMS AND CONDITIONS OF SALE ST DISCLAIMS ANY EXPRESS OR IMPLIED WARRANTY WITH RESPECT TO THE USE AND/OR SALE OF ST PRODUCTS INCLUDING WITHOUT LIMITATION IMPLIED WARRANTIES OF MERCHANTABILITY, FITNESS FOR A PARTICULAR PURPOSE (AND THEIR EQUIVALENTS UNDER THE LAWS OF ANY JURISDICTION), OR INFRINGEMENT OF ANY PATENT, COPYRIGHT OR OTHER INTELLECTUAL PROPERTY RIGHT.**

**ST PRODUCTS ARE NOT DESIGNED OR AUTHORIZED FOR USE IN: (A) SAFETY CRITICAL APPLICATIONS SUCH AS LIFE SUPPORTING, ACTIVE IMPLANTED DEVICES OR SYSTEMS WITH PRODUCT FUNCTIONAL SAFETY REQUIREMENTS; (B) AERONAUTIC APPLICATIONS; (C) AUTOMOTIVE APPLICATIONS OR ENVIRONMENTS, AND/OR (D) AEROSPACE APPLICATIONS OR ENVIRONMENTS. WHERE ST PRODUCTS ARE NOT DESIGNED FOR SUCH USE, THE PURCHASER SHALL USE PRODUCTS AT PURCHASER'S SOLE RISK, EVEN IF ST HAS BEEN INFORMED IN WRITING OF SUCH USAGE, UNLESS A PRODUCT IS EXPRESSLY DESIGNATED BY ST AS BEING INTENDED FOR "AUTOMOTIVE, AUTOMOTIVE SAFETY OR MEDICAL" INDUSTRY DOMAINS ACCORDING TO ST PRODUCT DESIGN SPECIFICATIONS. PRODUCTS FORMALLY ESCC, QML OR JAN QUALIFIED ARE DEEMED SUITABLE FOR USE IN AEROSPACE BY THE CORRESPONDING GOVERNMENTAL AGENCY.**

Resale of ST products with provisions different from the statements and/or technical features set forth in this document shall immediately void any warranty granted by ST for the ST product or service described herein and shall not create or extend in any manner whatsoever, any liability of ST.

ST and the ST logo are trademarks or registered trademarks of ST in various countries.

Information in this document supersedes and replaces all information previously supplied.

The ST logo is a registered trademark of STMicroelectronics. All other names are the property of their respective owners.

© 2013 STMicroelectronics - All rights reserved

STMicroelectronics group of companies

Australia - Belgium - Brazil - Canada - China - Czech Republic - Finland - France - Germany - Hong Kong - India - Israel - Italy - Japan - Malaysia - Malta - Morocco - Philippines - Singapore - Spain - Sweden - Switzerland - United Kingdom - United States of America

[www.st.com](http://www.st.com)