

# TR Series

## TO-220 and TO-247 Style Power Resistor

- TR20/30/35/50/50H comes in TO-220 style power package
- TR100 available in TO-247 style power package
- TR30/35/50H/100 has single screw mounting to heat sink
- Molded case for environmental protection
- Electrically isolated case
- Non-inductive package



Electrical Specifications									
Type / Code	Package Style	Power Rating (Watts) @ 25°C with Heat Sink (3)	Power Rating (Watts) @ 25°C	Maximum Working Voltage(1)	Resistance Temperature Coefficient	Ohmic Range (Ω) and Tolerance			
						0.5%	1%	5%	10%
TR20	TO-220	20W	3W	350V	±50 ppm/°C	10 - 10K	10 - 10K	10 - 10K	10 - 10K
TR30	TO-220	30W	2.25W		±100 ppm/°C	10 - 10K	3 - 10K	3 - 10K	3 - 10K
TR35	TO-220	35W	2.5W		±200 ppm/°C	10 - 10K	3 - 10K	3 - 10K	3 - 10K
					±300 ppm/°C (2)	-	1 - 3	1 - 3	1 - 3
TR50	TO-220	50W	3W	350V	±50 ppm/°C	10 - 10K	10 - 10K	10 - 10K	10 - 10K
					±100 ppm/°C	10 - 10K	3 - 10K	3 - 10K	3 - 10K
					±200 ppm/°C	10 - 10K	3 - 10K	3 - 10K	3 - 10K
TR50H	TO-220	50W	2.25W	420V	±300 ppm/°C (2)	-	1 - 3	1 - 3	1 - 3
						-	-	0.1 - 1	0.1 - 1
TR100	TO-247	100W	3.5W	700V	±50 ppm/°C	-	10 - 10K	10 - 10K	10 - 10K
					±100 ppm/°C	-	3 - 10K	3 - 10K	3 - 10K
					±200 ppm/°C	-	3 - 10K	3 - 10K	3 - 10K
					±300 ppm/°C (2)	-	1 - 3	1 - 3	1 - 3
						-	-	0.05 - 1	0.05 - 1

(1) Lesser of  $\sqrt{PR}$  or maximum working voltage

(2) Unspecified TCR. Contact Factory.

(3) The case temperature is to be used for the definition of the applied power limit. Refer to Power Derating Curve.

Environmental Characteristics			
Test Item	Specification		Test Method
	TR20/30/35/50/50H	TR100	
Short Time Overload	$\Delta R \pm (0.3\% + 0.001\Omega)$	$\Delta R \pm (0.5\% + 0.001\Omega)$	2 times rated power with applied voltage not to exceed 1.5 times maximum continuous operating voltage for 5 seconds
Load Life	$\Delta R \pm (1\% + 0.001\Omega)$	$\Delta R \pm (1\% + 0.001\Omega)$	MIL-R-39009, 2000 hours at rated power
Moisture Resistance	$\Delta R \pm (0.5\% + 0.001\Omega)$	$\Delta R \pm (0.5\% + 0.001\Omega)$	MIL-STD-202, Method 103B
Thermal Shock	$\Delta R \pm (0.3\% + 0.001\Omega)$	$\Delta R \pm (0.5\% + 0.001\Omega)$	MIL-STD-202, Method 107G
Terminal Strength	$\Delta R \pm (0.2\% + 0.001\Omega)$	$\Delta R \pm (0.2\% + 0.001\Omega)$	MIL-STD-202, Method 211, Condition A (Pull Test) 2.4N
Vibration, High Frequency	$\Delta R \pm (0.2\% + 0.001\Omega)$	$\Delta R \pm (0.4\% + 0.001\Omega)$	MIL-STD-202, Method 204, Condition D
Dielectric Strength	1800VAC		
Insulation Resistance	10GΩ min.		

Operating Temperature Range: -65°C to + 150°C (TR20/TR30/TR50/TR50H)  
 -65°C to + 175°C (TR35/TR100)

Mechanical Specifications							
Type Code	TR20	TR30	TR35	TR50	TR50H	TR100	Units
A	0.41 ± 0.01 10.41 ± 0.26	0.41 ± 0.01 10.41 ± 0.26	0.4 ± 0.01 10.16 ± 0.25	0.41 ± 0.01 10.41 ± 0.26	0.41 ± 0.01 10.41 ± 0.26	0.62 ± 0.01 15.75 ± 0.26	inches mm
B	0.64 ± 0.01 16.26 ± 0.26	0.64 ± 0.01 16.26 ± 0.26	0.58 ± 0.01 14.75 ± 0.25	0.64 ± 0.01 16.26 ± 0.26	0.64 ± 0.01 16.26 ± 0.26	0.815 ± 0.01 20.7 ± 0.26	inches mm
C	0.125 ± 0.01 3.18 ± 0.26	0.125 ± 0.01 3.18 ± 0.26	0.17 ± 0.015 4.44 ± 0.38	0.125 ± 0.01 3.18 ± 0.26	0.125 ± 0.01 3.18 ± 0.26	0.195 ± 0.01 4.95 ± 0.26	inches mm
D	0.05 ± 0.005 1.27 ± 0.13	0.05 ± 0.005 1.27 ± 0.13	0.05 ± 0.005 1.27 ± 0.13	0.05 ± 0.005 1.27 ± 0.13	0.05 ± 0.005 1.27 ± 0.13	0.143 ± 0.007 3.63 ± 0.18	inches mm
E	0.03 ± 0.004 0.76 ± 0.1	0.03 ± 0.004 0.76 ± 0.1	0.031 ± 0.003 0.78 ± 0.08	0.03 ± 0.004 0.76 ± 0.1	0.03 ± 0.004 0.76 ± 0.1	0.06 ± 0.004 1.52 ± 0.1	inches mm
F	0.2 ± 0.01 5.08 ± 0.26	0.2 ± 0.01 5.08 ± 0.26	0.2 ± 0.01 5.08 ± 0.26	0.2 ± 0.01 5.08 ± 0.26	0.2 ± 0.01 5.08 ± 0.26	0.4 ± 0.01 10.16 ± 0.26	inches mm
G	0.13 ± 0.03 3.3 ± 0.76	0.13 ± 0.03 3.3 ± 0.76	0.13 ± 0.03 3.3 ± 0.76	0.13 ± 0.03 3.3 ± 0.76	0.13 ± 0.03 3.3 ± 0.76	0.11 ± 0.03 2.79 ± 0.76	inches mm
H	0.5 ± 0.05 12.7 ± 1.27	0.5 ± 0.05 12.7 ± 1.27	0.539 ± 0.04 13.7 ± 1	0.5 ± 0.05 12.7 ± 1.27	0.5 ± 0.05 12.7 ± 1.27	0.57 ± 0.05 14.48 ± 1.27	inches mm
J	0.019 ± 0.004 0.5 ± 0.1	0.019 ± 0.004 0.5 ± 0.1	0.024 ± 0.003 0.62 ± 0.08	0.019 ± 0.004 0.5 ± 0.1	0.019 ± 0.004 0.5 ± 0.1	0.032 ± 0.01 0.81 ± 0.26	inches mm
K	0.07 ± 0.01 1.78 ± 0.26	0.07 ± 0.01 1.78 ± 0.26	0.09 ± 0.01 2.28 ± 0.25	0.07 ± 0.01 1.78 ± 0.26	0.07 ± 0.01 1.78 ± 0.26	0.095 ± 0.01 2.41 ± 0.26	inches mm
M	-	0.125 ± 0.004 3.18 ± 0.1	0.144 ± 0.004 3.65 ± 0.1	-	0.125 ± 0.004 3.18 ± 0.1	0.143 ± 0.004 3.63 ± 0.18	inches mm
N	-	0.125 ± 0.01 3.18 ± 0.26	0.116 ± 0.004 2.95 ± 0.1	-	0.125 ± 0.01 3.18 ± 0.26	0.21 ± 0.01 5.33 ± 0.26	inches mm
O	-	-	0.051 ± 0.004 1.3 ± 0.1	-	-	-	inches mm
P	-	-	0.24 ± 0.004 6.1 ± 0.1	-	-	-	inches mm

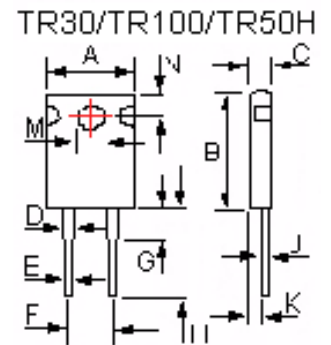
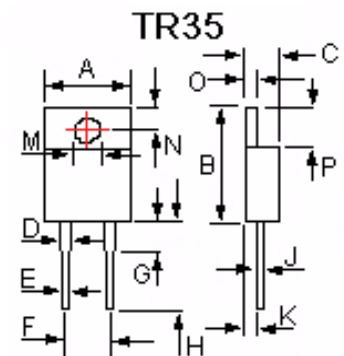
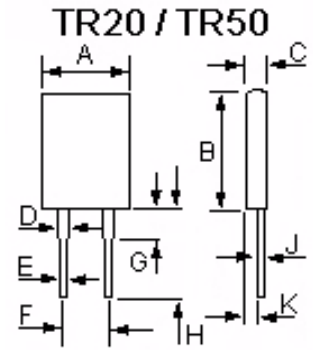

**Mounting Note:**

- (1) When mounting ensure entire ceramic portion of case is mounted on a clean, flat heat sink with an appropriate thermal interface, such as thermal grease. For screw mounting use of a compression washer at a force of 150 to 300lbs (665 to 1330N) is recommended without exceeding mounting torque of 8 in-lbs (0.9 N-m) to avoid package damage. For clip mounting use of a round or smooth clip in contact area is recommended to avoid a concentrated hot spot on package.
- (2) TR50/100 must be mounted to heat sink using proper mounting clip for efficient heat dissipation.

Power Derating Curve:

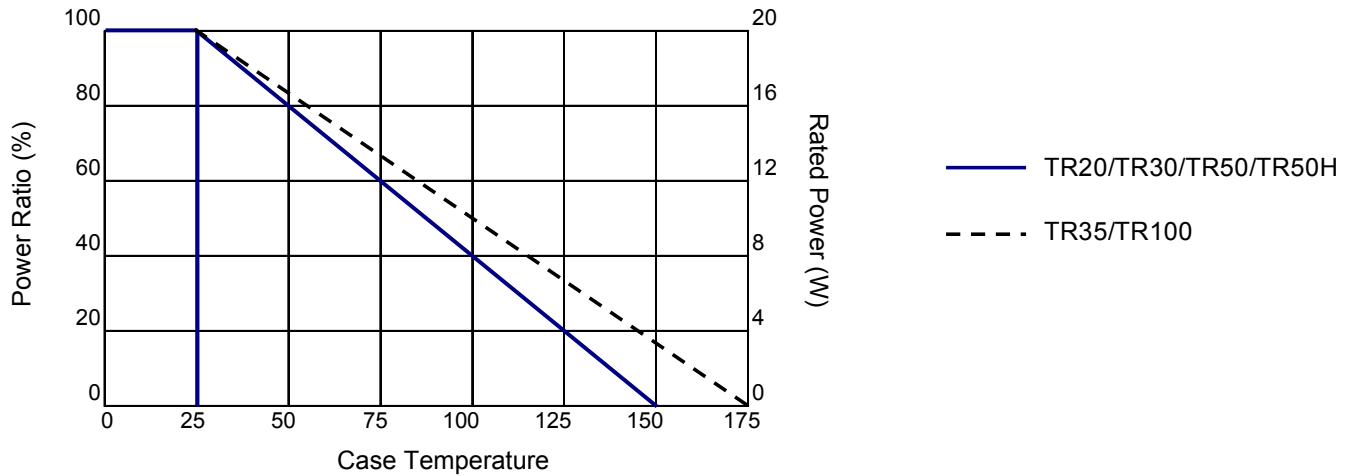

**How to Order**

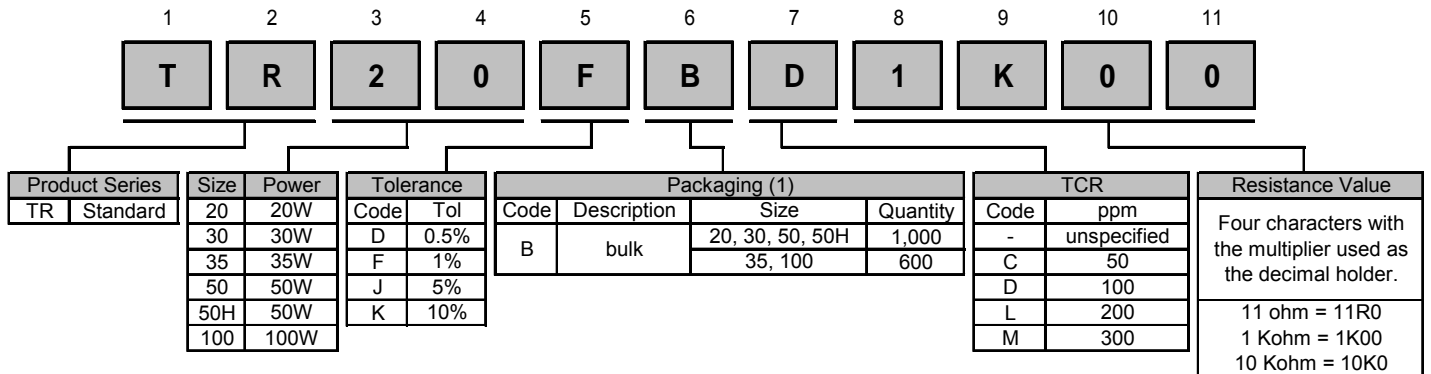

(1) Tube Packaging may be available for large volumes. Please contact factory for details.

Legacy Part Number (before January 3, 2011):

SEI Type		Code		TCR		Nominal Resistance	Tolerance	Packaging (1)			
<b>TR</b>		<b>20</b>		<b>T1</b>		<b>1K</b>	<b>1%</b>	<b>B</b>			
Type	Description	Code	Wattage	Code	TCR	Tolerance		Style	Qty	Description	Code
TR	Standard	20	20W	-	Unspecified	±0.5%		20, 30, 50, 50H	1,000	Box	B
		30	30W	T2	50 ppm	±1%		35, 100	600		
		35	35W	T1	100 ppm	±5%					
		50	50W	T0	200 ppm	±10%					
		50H	50W								
		100	100W								

(1) Tube Packaging may be available for large volumes. Please contact factory for details.