

# EMI Filters and Filtered Interconnects



**ISO 9001**  
CERTIFIED



**SPECTRUM CONTROL INC.**  
A Control Products and Systems Company  
**Signal and Power Integrity Group**



**SPECTRUM CONTROL INC.**  
A Control Products and Systems Company  
**Signal Products Group**

# EMI Filters and Filtered Interconnects

*Since its founding in 1968, Spectrum Control has focused on being a total solutions provider in the suppression or elimination of electromagnetic interference (EMI). Through recent acquisitions, Spectrum Control now offers the industry's broadest line of EMI/RFI filters, capacitors, surface mount filters and inductors, filtered arrays, filtered connectors, filtered datacom connectors, power products, power distribution filters and EMC testing services.*

*Spectrum Control is committed to providing an integrated approach to EMC problem solving by offering customers comprehensive consulting, diagnostic testing and manufacturing services. Products from Spectrum Control are used in all major electronics markets including telecommunications, medical, aerospace avionics and industrial electronics, as well as industrial appliances.*

**ISO 9001**  
CERTIFIED

## Spectrum Control Inc...

**Surface Mount  
Filters &  
Inductors**



**Low Pass  
Filters**

**Filtered  
Arrays**



**Filtered  
Connectors**





**Gaskets &  
Shielding**



		<b>Pages</b>		
<b>Surface Mount Filters &amp; Inductors</b>	<ul style="list-style-type: none"> <li>• Three Terminal Chip EMI Filters</li> <li>• LC Type Chips</li> <li>• Square Surface Mount EMI Filters</li> </ul>	<ul style="list-style-type: none"> <li>• High Current Power SMD EMI Filters</li> <li>• High Frequency Thru-Hole PCB Filters</li> </ul>	<b>19-60</b>	
<b>Low Pass Filters</b>	<ul style="list-style-type: none"> <li>• MLFT Filters</li> <li>• Solder-in Filters</li> <li>• Resin Sealed Bolt-in Filters</li> </ul>	<ul style="list-style-type: none"> <li>• High Current/High Voltage Resin Sealed Filters</li> <li>• Hermetically Sealed Case Filters</li> </ul>	<b>56-100</b>	
<b>Filtered Arrays</b>	<ul style="list-style-type: none"> <li>• Easy Mate<sup>®</sup> Filter Plates</li> <li>• Bolt-in Filter Plates</li> <li>• Custom Filter Plates &amp; Terminal Blocks</li> <li>• Barrier Strip Filtered Terminal Blocks</li> </ul>	<ul style="list-style-type: none"> <li>• PCB Mount Filtered Terminal Blocks</li> </ul>	<b>101-124</b>	
<b>Filtered Connectors</b>	<ul style="list-style-type: none"> <li>• Series F Ferrite Filtered Connectors</li> <li>• Series 100 Chip-Cap Filtered Connectors</li> <li>• Series 500 Low Profile Feed-thru Connectors</li> </ul>	<ul style="list-style-type: none"> <li>• Series 600 Hi-Density Filtered Connectors</li> <li>• Series 700 High Performance Filtered Connectors</li> <li>• Filtered Combo D-Subminiature Connectors</li> </ul>	<ul style="list-style-type: none"> <li>• Series E (ESD/EFT) Transient Protected Connectors</li> <li>• Datacom Connectors</li> <li>• Custom Filtered Connectors</li> </ul>	<b>125-226</b>
<b>Quietshield™ Gaskets &amp; Shielding</b>	<ul style="list-style-type: none"> <li>• Quietshield “D” Profile Gaskets</li> <li>• Quietshield “P” Profile Gaskets</li> <li>• Clips</li> <li>• Quietshield “R” Profile Gaskets</li> </ul>	<ul style="list-style-type: none"> <li>• Quietshield “L” Profile Gaskets</li> <li>• I/O Gaskets - “D”</li> <li>• Custom Shielding Products</li> <li>• EMI Shielding Tapes</li> </ul>	<b>227-236</b>	
<b>Appendix</b>	<ul style="list-style-type: none"> <li>• Military Cross Reference</li> <li>• SCI/Amp Cross Reference</li> <li>• Part Number Index</li> <li>• <a href="http://www.spectrumcontrol.com">www.spectrumcontrol.com</a> Online tools</li> </ul>		<b>237-251</b>	





# EMI Filters and Filtered Interconnects Selection Guide

## LOW PASS FILTERS

	<b>Power Surface Mount (PSM) Square Surface Mount (SSM) Filters</b>	<b>Microwave Discrete Filters</b>	<b>Resin Sealed/ Solder-in Capacitors and Filters</b>	<b>Hermetically Sealed Filters and Capacitors</b>
<b>Applications</b>	 Power amplifiers, power supplies, temperature and motor controls, high current bus lines and driver circuits	 Ideal for microwave applications such as attenuators and oscillators. Perform well in high impedance circuits where large capacitance values are not practical	 Telecommunications equipment, transceivers, microwave filters, industrial control systems, multi-circuit filter assemblies	 Power supplies, signal lines, rocket igniters, aerospace, military/secure communications, medical equipment multisection filters, and mining and oil drilling exploration
<b>Features/ Benefits</b>	<ul style="list-style-type: none"> <li>■ <b>Current rating</b> – PSM - 20 Amps (FT) and 10 Amps (Pi) SSM - 10 Amps</li> <li>■ <b>Construction</b> – High temperature construction</li> <li>■ <b>Small size</b> – Square mechanical geometry enhances soldering to a PCB</li> <li>■ <b>Packaging</b> – Tape and reel packaging along with bulk packaging</li> </ul>	<ul style="list-style-type: none"> <li>■ <b>Small size options</b> – Solder-in Press-in 2-56 threaded</li> <li>■ <b>Construction</b> – High temperature constructions</li> <li>■ <b>Plating</b> – Suitable for gold bonding when specified</li> <li>■ <b>Coaxial</b> – Feed-thru filtering</li> </ul>	<ul style="list-style-type: none"> <li>■ <b>Cost effective</b> – Resin sealed filters provide environmental protection at low cost</li> <li>■ <b>Design flexibility</b> – Wide range of threaded and solder-in bushings with a variety of circuits: C, L, and Pi</li> <li>■ <b>Reliability</b> – All parts built in accordance with MIL-F-15733 and MIL-F-28861</li> <li>■ <b>Safety</b> – Some select filters U.L. 1459 recognized and CSA C22.2 certified</li> <li>■ <b>FED/MIL approvals</b> – Qualified to MIL-F-15733</li> </ul>	<ul style="list-style-type: none"> <li>■ <b>Hermetically sealed</b> – Ideal for use in hostile environments</li> <li>■ <b>Design flexibility</b> – Wide range of bushing sizes and circuit types including C, L, Pi, transient suppression Pi, T, &amp; TT</li> <li>■ <b>Reliability</b> – Built in accordance with MIL-F-15733 and MIL-F-28861, with QPL listings on both MIL-F-28861 and space application 'S' level available</li> <li>■ <b>FED/MIL approvals</b> – Qualified to MIL-F-15733 and MIL-F-28861</li> </ul>
<b>Performance Characteristics</b>	<ul style="list-style-type: none"> <li>■ <b>Insertion loss range</b> – Effective filtering to 18 GHz in a shielded application</li> <li>■ <b>Capacitance</b> – Pi: 68 pF to 4000 pF Feed-thru: 68 pF to .01 <math>\mu</math>F</li> <li>■ <b>Temperature range</b> – -55°C to +125°C</li> </ul>	<ul style="list-style-type: none"> <li>■ <b>Insertion loss range</b> – Effective filtering to 18 GHz in a shielded application</li> <li>■ <b>Capacitance</b> – Up to 30,000 pF</li> <li>■ <b>Operating voltage</b> – Up to 200 VDC</li> <li>■ <b>Temperature range</b> – -55° to +125° C</li> </ul>	<ul style="list-style-type: none"> <li>■ <b>Insertion loss range</b> – Effective filtering from 1 MHz to 18 GHz with proper installation</li> <li>■ <b>Capacitance and temperature characteristics</b> – To 1.4 <math>\mu</math>F NPO, X7R, Z5U</li> <li>■ <b>Temperature range</b> – -55°C to +125°C</li> <li>■ <b>Voltage ratings (max.)</b> – To 2500 VDC 240 VAC @ 400 Hz</li> <li>■ <b>Current ratings (max.)</b> – To 100 Amps</li> </ul>	<ul style="list-style-type: none"> <li>■ <b>Insertion loss range</b> – Effective filtering from 1 MHz to 18 GHz with proper installation</li> <li>■ <b>Capacitance and temperature characteristics</b> – To 1.4 <math>\mu</math>F NPO, X7R, Z5U</li> <li>■ <b>Temperature range</b> – -55°C to +125°C</li> <li>■ <b>Voltage ratings (max.)</b> – To 400 VDC 240 VAC @ 400 Hz</li> <li>■ <b>Current ratings (max.)</b> – To 30 Amps</li> </ul>
	<i>Pages 56-59</i> <a href="http://www.spectrumcontrol.com/hcsmt">www.spectrumcontrol.com/hcsmt</a>	<i>Pages 69-70</i> <a href="http://www.spectrumcontrol.com/mwdis">www.spectrumcontrol.com/mwdis</a>	<i>Pages 71-83</i> <a href="http://www.spectrumcontrol.com/resin">www.spectrumcontrol.com/resin</a>	<i>Pages 84-99</i> <a href="http://www.spectrumcontrol.com/glass">www.spectrumcontrol.com/glass</a>





# EMI Filters and Filtered Interconnects Selection Guide

## FILTERED ARRAYS

	Filter Plate Assemblies	Shrouded Latch Plates	Microcircuit Packages	Filtered Terminal Blocks
<b>Applications</b>	 <p>Telecommunications equipment, cellular base stations, linear power amplifiers, cellular microcell repeaters, industrial, scientific, remote sensory, and medical equipment</p>	 <p>Telecommunications equipment, cellular base stations, linear power amplifiers, cellular microcell repeaters, industrial, scientific, remote sensory, and medical equipment</p>	 <p>Telecommunications equipment, scientific equipment, aerospace applications and point-to-point telemetry</p>	 <p>Telecommunications equipment, industrial controls, power supplies, uninterruptible power supplies, instrumentation and power distribution equipment</p>
<b>Features/ Benefits</b>	<ul style="list-style-type: none"> <li>■ <b>Total reduced costs</b> – Economical method of meeting EMC requirements</li> <li>■ <b>Excellent filtering</b> – Outperform surface mount filters at frequencies above 130 MHz; provide an EMI filtered signal line between electronic system modules</li> <li>■ <b>Reliability</b> – Every filter plate is tested 100% for key parameters</li> <li>■ <b>Standard centers</b> – Of 0.100" and 2mm allow for easy termination</li> <li>■ <b>Easy Mate™ filter plate</b> – Design provides for quick installation into predefined cutout</li> </ul>	<ul style="list-style-type: none"> <li>■ <b>Design flexibility</b> – Available in 10 to 64 positions Mates to most ribbon cable connectors A variety of latch ejector heights available Mixed capacitance values and schematics available</li> <li>■ <b>Standard centers</b> – Pins on .100" centers</li> <li>■ <b>Reliability</b> – Cable retention reliable in vibration prone environments</li> <li>■ <b>Excellent filtering</b> – From 5 MHz to 1 GHz and beyond</li> <li>■ <b>Rugged construction</b> – Shroud protects filter element from potential damage</li> </ul>	<ul style="list-style-type: none"> <li>■ <b>Total reduced costs</b> – Allow users to reduce production and installation time while lowering overall costs</li> <li>■ <b>Design flexibility</b> – Wide variety of shapes and sizes Housing materials include: Kovar, Aluminum, Copper, Titanium and Copper Alloys Variety of circuits: C, L and Pi Connectors offered are: RF, SMA, Bias Pins and Snap-ins</li> <li>■ <b>Hermetically sealed</b> – Available in both hermetic and non-hermetic packaging</li> </ul>	<ul style="list-style-type: none"> <li>■ <b>Rugged construction</b> – Provides protection to filtering element; especially useful for repeated changes in field wiring</li> <li>■ <b>Design flexibility</b> – 2 to 6 terminals available in either the "Barrier Strip" or European variety</li> <li>■ <b>Performance</b> – Filter elements provide high insertion loss for EMI filtering of DC power and control lines</li> <li>■ <b>Reliability</b> – Every terminal block is tested 100% for key parameters</li> <li>■ <b>European style blocks</b> – Available in English and metric spacing</li> <li>■ <b>FED/MIL approvals</b> – Barrier strips are recognized to U.L. 1059 file E133076 and approved by CSA Std 22.2 No. 158-1987 and ECN584B, LR92537; 52-160 series 100 VDC UL/CSA 52-257 series 250 VAC UL/CSA</li> </ul>
<b>Performance Characteristics</b>	<ul style="list-style-type: none"> <li>■ <b>Insertion loss range</b> – Effective insertion loss from 1 MHz to 18 GHz with proper installation</li> <li>■ <b>Capacitance</b> – Pi: 68 pF to 5000 pF Feed-thru: 68 pF to 4000 pF</li> <li>■ <b>Temperature characteristics</b> – NPO, X7R, Z5U</li> <li>■ <b>Temperature range</b> – -55°C to +125°C</li> <li>■ <b>Voltage ratings (max.)</b> – To 250 VDC</li> <li>■ <b>Current ratings (max.)</b> – To 5 Amps standard</li> </ul>	<ul style="list-style-type: none"> <li>■ <b>Insertion loss range</b> – Effective insertion loss from 1 MHz to 18 GHz with proper installation</li> <li>■ <b>Capacitance</b> – Pi: 68 pF to 5000 pF Feed-thru: 68 pF to 4000 pF</li> <li>■ <b>Temperature characteristics</b> – NPO, X7R, Z5U</li> <li>■ <b>Temperature range</b> – -55°C to +125°C</li> <li>■ <b>Voltage ratings (max.)</b> – To 250 VDC</li> <li>■ <b>Current ratings (max.)</b> – To 5 Amps standard</li> </ul>	<ul style="list-style-type: none"> <li>■ <b>Insertion loss range</b> – From 1 MHz to 18 GHz</li> <li>■ <b>Temperature range</b> – -55°C to +125°C</li> <li>■ <b>Voltage ratings (max.)</b> – To 200 VDC</li> <li>■ <b>Current ratings (max.)</b> – To 5 Amps</li> </ul>	<ul style="list-style-type: none"> <li>■ <b>Insertion loss range</b> – Effective insertion loss from 1 MHz to 18 GHz with proper installation</li> <li>■ <b>Capacitance</b> – 2500 pF to 5200 pF</li> <li>■ <b>Temperature range</b> – -55°C to +105°C</li> <li>■ <b>Voltage ratings (max.)</b> – Barrier: to 250 VAC European: to 100 VDC</li> <li>■ <b>Current ratings (max.)</b> – Barrier: 20 Amps European: 12 Amps</li> </ul>
	Pages 103-113 <a href="http://www.spectrumcontrol.com/array">www.spectrumcontrol.com/array</a>	Pages 114-115 <a href="http://www.spectrumcontrol.com/array">www.spectrumcontrol.com/array</a>	Pages 116-119 <a href="http://www.spectrumcontrol.com/mcpck">www.spectrumcontrol.com/mcpck</a>	Pages 120-124 <a href="http://www.spectrumcontrol.com/array">www.spectrumcontrol.com/array</a>

# EMI Filters and Filtered Interconnects Selection Guide

## FILTERED CONNECTORS

	<b>Ferrite Filtered D-Subminiature Connectors .318" Footprint</b>	<b>Feed-Thru &amp; Chip-Cap Filtered D-Subminiature Connectors .318" Footprint</b>	<b>Filtered Combo Connectors</b>	<b>High Performance Filtered D-Subminiature Connectors .590" Footprint and Adapters</b>
<b>Applications</b>	 Personal computers, microcomputers-applied products and peripheral/terminal equipment	 Personal computers, industrial process equipment, cellular base stations, PBX telecommunications equipment, graphics workstations, and medical electronics	 Telecommunications base station equipment, 48 volt DC power, switching and transmission equipment, power supplies, industrial equipment, computer work stations, medical electronics	 Telecommunications equipment, cellular base stations, secured communications, medical electronics, industrial process equipment, microwave TX/RX, personal computers, graphics workstations and aerospace applications
<b>Features/ Benefits</b>	<ul style="list-style-type: none"> <li>■ <b>Cost-effective solutions</b> – Low cost, high performance; replaces individual ferrite bead filters, saving cost and space</li> <li>■ <b>Design flexibility</b> – Available in 9, 15, 25 lines standard density, 15-line hi-density and stacked construction</li> <li>■ <b>Compact design</b> – Short, space saving .318" footprint interchangeable with standard D-subminiature connectors</li> <li>■ <b>Performance</b> – Gold plated contacts</li> <li>■ <b>FED/MIL approvals</b> – UL 94V-0</li> </ul>	<ul style="list-style-type: none"> <li>■ <b>Cost-effective solutions</b> – Low cost, high performance; replaces individual chip capacitor filters on the PCB/ integrated chips, with feed-thru capacitors, or chip-on-board filters, saving cost and space</li> <li>■ <b>Design flexibility</b> – Available in 9, 15, 25, 37 lines standard density</li> <li>■ <b>Compact design</b> – Short, space saving .318", .405" and .590" footprint interchangeable with standard D-subminiature connectors</li> <li>■ <b>Performance</b> – Superior filtering of high frequency interference; ground plane design provides superior EMI shielding; gold plated contacts</li> <li>■ <b>Reliability</b> – Each connector position is tested 100% for critical electrical parameters to ensure consistent performance</li> <li>■ <b>FED/MIL approvals</b> – UL 94V-0, UL/CSA recognized</li> </ul>	<ul style="list-style-type: none"> <li>■ <b>Excellent filtering</b> – Of signal contacts, power and coaxial contacts with high performing coaxial feed-thru capacitors: ground plane design provides superior EMI shielding</li> <li>■ <b>Design flexibility</b> – Available in a wide variety of mixed versions with different accessories</li> <li>■ <b>Reliability</b> – Each connector position is tested 100% for critical electrical parameters to ensure consistent performance</li> <li>■ <b>Options</b> – Available with hardware, gasketing, hooded strain relief</li> </ul>	<ul style="list-style-type: none"> <li>■ <b>Excellent filtering</b> – Filter types include high performing Pi or feed-thru capacitors; ground plane design provides superior EMI shielding</li> <li>■ <b>Design flexibility</b> – 9 to 50-line construction, combined power contacts, and selectively loaded lines</li> <li>■ <b>Reliability</b> – Each connector position is tested 100% for critical electrical parameters to ensure consistent performance</li> <li>■ <b>Numerous options</b> – Hardware, mounting, waved metal gaskets, hooded strain reliefs, combined filter types, plating, etc.</li> <li>■ <b>FED/MIL approvals</b> – UL 94V-0, UL/CSA recognized</li> </ul>
<b>Performance Characteristics</b>	<ul style="list-style-type: none"> <li>■ <b>Insertion loss range</b> – 10 to 300 MHz</li> <li>■ <b>Temperature range</b> – -40°C to +105°C</li> <li>■ <b>Voltage ratings (max.)</b> – 500 VDC</li> <li>■ <b>Current ratings (max.)</b> – 5 Amps</li> </ul>	<ul style="list-style-type: none"> <li>■ <b>Insertion loss range</b> – 1 MHz to 18 GHz and beyond</li> <li>■ <b>Capacitance and temperature characteristics</b> – To 1500 pF To 47 nF for COB NPO, X7R, Z5U</li> <li>■ <b>Temperature range</b> – -40°C to +125°C</li> <li>■ <b>Voltage ratings (max.)</b> – 700 VDC</li> <li>■ <b>Current ratings (max.)</b> – 5 Amps</li> </ul>	<ul style="list-style-type: none"> <li>■ <b>Insertion loss range</b> – 1 MHz to 18 GHz and beyond</li> <li>■ <b>Capacitance and temperature characteristics</b> – 47 pF to 1500 pF</li> <li>■ <b>Temperature range</b> – -55°C to +125°C</li> <li>■ <b>Voltage ratings (max.)</b> – 1000 VDC</li> <li>■ <b>Current ratings (max.)</b> – Coax, 3A, Power 20 A and 40 A</li> </ul>	<ul style="list-style-type: none"> <li>■ <b>Insertion loss range</b> – 1 MHz to 18 GHz and beyond</li> <li>■ <b>Capacitance and temperature characteristics</b> – To 5000 pF NPO, X7R, Z5U</li> <li>■ <b>Temperature range</b> – -55°C to +125°C</li> <li>■ <b>Voltage ratings (max.)</b> – 1000 VDC</li> <li>■ <b>Current ratings (max.)</b> – 5 Amps</li> </ul>
	Pages 129-133 <a href="http://www.spectrumcontrol.com/serf">www.spectrumcontrol.com/serf</a>	Pages 134-141 <a href="http://www.spectrumcontrol.com/conn">www.spectrumcontrol.com/conn</a>	Pages 170-177 <a href="http://www.spectrumcontrol.com/combo">www.spectrumcontrol.com/combo</a>	Pages 146-169 <a href="http://www.spectrumcontrol.com/serf00">www.spectrumcontrol.com/serf00</a>

# EMI Filters and Filtered Interconnects Selection Guide

## FILTERED CONNECTORS

**Series E (ESD/EFT) Transient Protected Connectors**

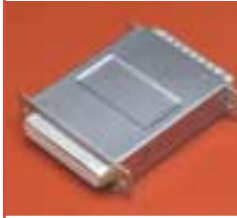

Network servers, firewalls, routers, test and diagnostic equipment, medical monitoring equipment, and I/O interfaces on many PC computer applications

**Applications**

- **Performance** – Complete ESD/EFT protection at the I/O ports and elimination of line-to-line noise problems and spark overs  
All lines have bi-directional protection  
Low ground impedance
- **Design flexibility** – Standard footprints save valuable board space and reduce additional ground traces
- **Cost effective solutions** – Reduction in total component use saves on hidden costs
- **Options** – Available in a wide variety of capacitance values, providing EMI protection  
Numerous mounting and hardware options

**Features/ Benefits**

- **Voltage ratings (max.)** – 700 VDC (for 5 seconds)
- **Current ratings (max.)** – 5 Amps
- **Capacitance and temperature characteristics** – 50 pF to 47,000 pF
- **Insulation resistance** – 500MΩ

**Performance Characteristics**

Pages 178-181

[www.spectrumcontrol.com/serie](http://www.spectrumcontrol.com/serie)

**High Density Filtered D-Subminiature Connectors and Adapters**



Telecommunications equipment, personal computers, graphic workstations, VGA applications, medical and industrial process equipment and aerospace applications

- **Excellent filtering** – Filtering high performance feed-thru capacitors; ground plane design provides superior EMI shielding
- **Design flexibility** – 15 to 78-line configurations and selectively loaded lines
- **Reliability** – Each connector position is tested 100% for critical electrical parameters to ensure consistent performance
- **Numerous options** – Hardware, mounting, waved metal gaskets, hooded strain reliefs, plating, etc.
- **FED/MIL approvals** – UL 94V-0, UL/CSA recognized

- **Insertion loss range** – 1 MHz to 18 GHz and beyond
- **Capacitance and temperature characteristics** – To 5000 pF  
NPO, X7R, Z5U
- **Temperature range** – -55°C to +125°C
- **Voltage ratings (max.)** – 1000 VDC
- **Current ratings (max.)** – 5 Amps

Pages 142-145

[www.spectrumcontrol.com/ser600](http://www.spectrumcontrol.com/ser600)

**Custom Filtered Connectors**



Commercial avionics, satellites, telecommunications, power supplies, electronic warfare, ground/air weapon systems and mining and oil drilling exploration

- **Excellent filtering** – Tubular and planar filtered arrays using Pi, LC, T, and C circuits; TVS protection available
- **Design flexibility** – Filtered MIL-C-38999 series available in compact and extended shells, MIL-C-83723, MIL-C-26482, MIL-C24308, in extended shell, as well as series 400 and 600 ARINC filtered connectors
- **Reliability** – Each connector position is tested 100% for critical electrical parameters

- **Insertion loss range** – Effective insertion loss from 1 MHz to 18 GHz with proper installation
- **Capacitance and temperature characteristics** – To 0.1 μF  
COG, X7R, Z5U
- **Temperature range** – -55°C to +125°C
- **Voltage ratings (max.)** – 125 VAC @ 400 Hz

Pages 198-225

[www.spectrumcontrol.com/cusconn](http://www.spectrumcontrol.com/cusconn)

**Filtered Miniature Ribbon RJ45 & RJ11 Datacom Connectors**



Original telephone manufacturing, operating telephone companies, cable reclamation, cable manufacturing and bay connectorization, LANs, WANs, network cards, broadband transmission equipment, workstations, peripherals, fax/modems, copy machines and multiplexing

- **Cost-effective solutions** – Modular jack connectors filtered with ferrite or capacitive film  
Miniature ribbon connectors filtered with chip capacitors
- **Design flexibility** – Modular jack connectors available in single or multipoint styles  
Miniature ribbon connectors available in 50-line configurations
- **Reliability** – Each connector is tested 100% for critical electrical parameters to ensure consistent performance

- **Insertion loss range** – 1 MHz to 18 GHz and beyond
- **Capacitance** – Up to 820 pF
- **Temperature range** – -55°C to +125°C
- **Voltage ratings (max.)** – 1000 VDC (Miniature ribbon connectors)  
707 VDC (Modular jack connectors)
- **Current ratings (max.)** – 5 Amps

Pages 182-189

[www.spectrumcontrol.com/data](http://www.spectrumcontrol.com/data)

**Quietshield Gasketing & Shielding**



Enclosures or cabinets of electronics equipment such as computers, networking and telecom equipment

- **Effectiveness** – Maintains shielding across seams or gaps  
Exclusive Quiet Contact provides instantaneous shielding upon initial contact of gasket
- **Design flexibility** – Available in a variety of profiles and sizes  
Custom lengths and shapes available
- **Rugged construction** – No creasing or tearing; fabric tensile strength up to 80 pounds/inch  
Lightweight material of 2.3 to 2.8 ounces/square yard
- **Shielding** – Superior shielding effectiveness of 70 dB between 1 MHz to 18 GHz

Pages 227-236

[www.spectrumcontrol.com/quietshield](http://www.spectrumcontrol.com/quietshield)

# Spectrum Control's Expertise

As a complete source of EMC solutions, Spectrum Control combines state-of-the-art test facilities with proven expertise in the design and manufacture of EMI/RFI filtering components.

To ensure filtering performance appropriate for the application, we utilize both tubular and discoidal capacitors, and C or Pi type filter elements. For pass-band requirements above 50 MHz, we provide unfiltered, insulated feed-thru lines.

For additional information or assistance, contact your local Spectrum Control representative or our Customer Engineering Department.

## Spectrum Control Offers:

**Engineering support** – Our engineering staff, with many years of experience in designing EMI filters, has developed sophisticated computer models to help us provide rapid and cost effective EMI solutions. Following an evaluation of your needs, we will produce an economical, space efficient filter, satisfying your compliance requirements.

**Reduced lead times and volume production** – Our vertical integration as a ceramic capacitor and filter producer enables us to reduce lead times for both prototyping and production orders . . . ensuring on-time delivery.

**Custom designs** – Through the use of all available ceramic capacitor options including tubular and discoidal capacitors, we offer maximum design versatility to meet the needs of any unique application. Filters are available in simple |C or Pi types, as well as any combination of capacitor, inductor, circuit voltage protection devices, such as diodes are also available.

**Full qualification testing** – In addition to our integral quality assurance process, we offer testing in compliance with MIL-F-28861, MIL-F-15733, MIL-STD-202 and other filter and connector specifications.

**Customer support programs** – We will work closely with your organization to help improve the final design and performance of your products, as well as increase your manufacturing and operational efficiency. Spectrum Control has instituted a variety of programs designed to maximize these opportunities.

- Flexible manufacturing to cut cycle times and meet deadlines
- EDI to streamline the transmitting of information
- Inventory Management through flexible shipping programs
- Consignment/schedule sharing programs to accommodate customers' forecasts
- Broader distribution base to make our products more readily available and accommodate vendor reduction plans
- New product development geared to meeting customer-specific requirements and targets

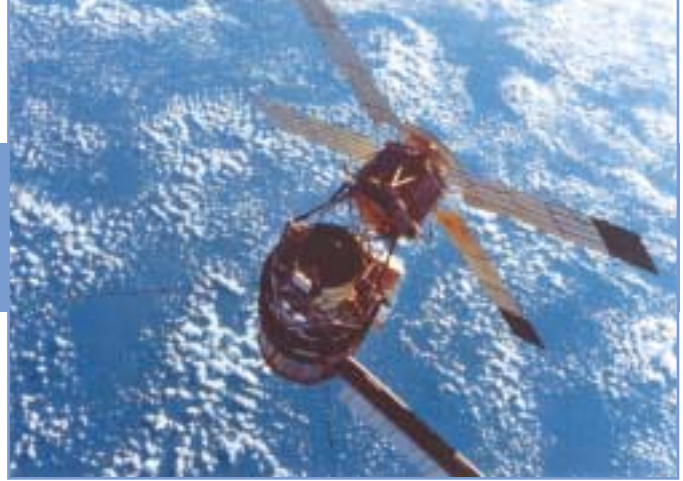

*Spectrum Control Inc. is*

**ISO 9001**  
CERTIFIED

## Spectrum Control's Expertise

### The Foundation: Ceramic Capacitors

Inside every Spectrum Control EMI filter is a ceramic feed-thru capacitor. Spectrum Control Technology Inc. has engineered a line of ceramic capacitors designed to provide solutions to a wide range of filtering applications. Our tubular and discoidal feed-thru capacitors offer enhanced performance to help you satisfy varied voltage, capacitance, and packaging requirements.

All Spectrum Control Technology Inc. ceramic capacitors are manufactured in our world-class ceramic facility which features highly automated, state-of-the-art equipment. By controlling the formulation of the ceramic material and the manufacturing process, Spectrum ensures the foundation of our EMI filters . . . the capacitor, is of the highest quality.

### The Spectrum Commitment

Spectrum Control, Inc. is committed to Operational Excellence . . . an all-consuming customer focus, embodied in our unbending commitment to quality, flexible and responsive factories, faster time to market, and organizational excellence.

We offer a comprehensive line of EMI/RFI filters, capacitors, filter plates, filtered connectors filtered terminal blocks, power line filters and EMC testing services for major OEM's serving a variety of industries throughout the world . . . telecommunication, computers, aerospace, military, instrumentation, medical devices and industrial controls. Our worldwide sales channels include distribution, as well as direct manufacturers representatives.

Our commitment to Operational Excellence enables us to provide innovative EMC solutions which meet our corporate mandate for world-class value, quality, and delivery. Spectrum Control Inc.'s manufacturing facilities have been audited and qualified to MIL-I-45208, and certified ISO 9001.

### Dedication to Quality

Spectrum Control has invested the resources necessary to establish the most efficient and accurate design, material, assembly and testing procedures. The Spectrum production process is an outgrowth of our Quality Management System which instills in every member of the Spectrum team a single-minded purpose of achieving defect-free production. We're proud to produce the highest quality and most reliable EMI filters, capacitors, and filtered connectors in the world.



### The EMC Test Solution

Our commitment to our customers goes much further than any other EMI filter manufacturer; we provide solutions to your EMI problems. That is why we have a fully equipped Electromagnetic Compatibility Test Laboratory and the expertise to solve the most demanding EMC challenge.

We can test your equipment, system, or sub-system to various domestic and international regulatory standards, determine state of compliance, and bring your equipment into compliance with the most cost effective solution. These services are available for a modest daily fee that is often lower than many EMC test houses charge for simply determining compliance or noncompliance.

No other EMI filter manufacturer can offer this total solution and the wide range of available Spectrum Control EMI filtering products.

*For additional information regarding Spectrum Control, our EMI filtering products and our many new products, call us or contact our web site at <http://www.spectrumcontrol.com>*

# Application Guidelines

## Sources of EMI

Electromagnetic interference occurs naturally from terrestrial sources such as lightning discharges, precipitation, and sand and dust storms, in addition to cosmic noise emanating from sources within and outside our solar system. Man-made sources include power lines, rotating machinery, ignition systems, television and radio receivers, fluorescent lights, power amplifiers, computing devices and transmitters of all types.

## Interference Suppression

Filter networks suppress electromagnetic interference in two basic ways. The capacitor elements shunt the interference to ground, and the series inductor elements raise the impedance of the line making the shunt capacitor elements even more effective.

## Capacitor Elements

The types of capacitors used in Spectrum Control filters are often referred to as feed-thru capacitors due to their physical geometry.

The feed-thru design results in greatly reduced self-inductance compared to standard leaded capacitors. Also, this design effectively prevents radiation from the input coupling directly with the output of the capacitor, unlike leaded or chip capacitors. The combination of low inductance and high input/output isolation provides excellent shunting of EMI for frequencies up to and beyond 1 GHz.

The simplest feed-thru type is a ceramic tube that may have buried electrodes and can be constructed as a single capacitor or as two capacitors, as used in a Pi section filter. This type of device can have capacitance values from 10 pF to 0.1  $\mu$ F and typical working voltage ratings up to 2500 VDC. Due to the simple construction, these capacitors are very efficient at frequencies up to 10 GHz and exhibit no pronounced resonances.

Multilayer monolithic discoidal capacitors are used for very high capacitance parts in standard sizes or for smaller filters where the required capacitance cannot be achieved by a ceramic tube. This type of capacitor consists of alternate layers of opposite polarity electrodes separated by a ceramic dielectric. Typical capacitance values from 100 pF to 10  $\mu$ F are available with working voltages up to 400 VDC.

## Inductive Elements

Ferrite sleeves are used with tubular capacitors since they can be conveniently accommodated inside the tube to provide a very compact filter. They are also used with discoidal capacitors in some applications. Wound inductors are used with discoidal capacitors to provide very high performance filters.

### Multilayer Discoidal Capacitor

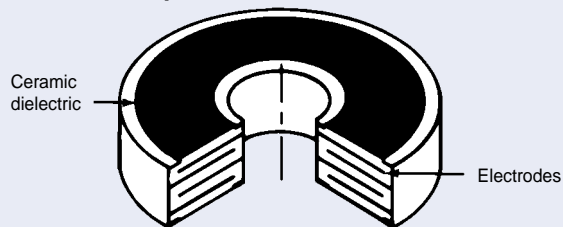

### Embedded Electrode Tubular Capacitor

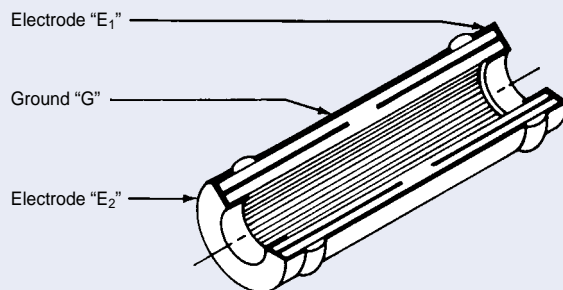

### Resin Sealed Filter

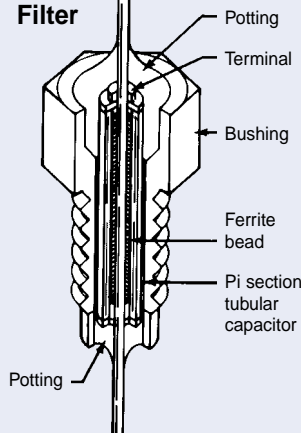

### Hermetically Sealed Filter

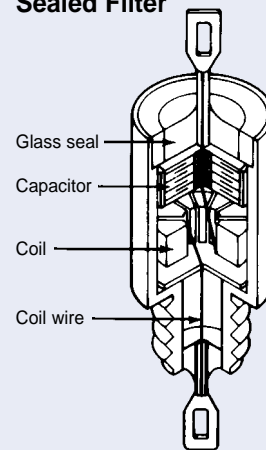

### Circular Filtered Connector

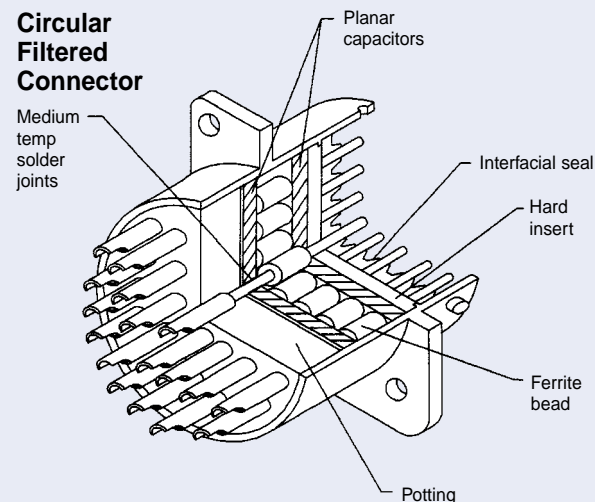

# Application Guidelines

Low Pass EMI filters are available in the following circuit configurations, schematics are shown at right.

## C Filter

The C filter is a three terminal feed-thru capacitor. It is used to attenuate high frequency signals.

## L Filter

An L filter consists of one inductive element and one capacitive element. This type of filter can offer high impedance or low impedance input depending upon its orientation in the circuit. It is most commonly used in applications where one has a high impedance load and a low impedance source (see LT), or where one has a high impedance source and a low impedance load (see LB).

## Pi Filter

The Pi filter contains two capacitive elements and one inductive element. It presents a low impedance to both the source and the load. Because of the additional element, it provides better high frequency performance than the C or L configurations. Due to the possibility of 'ringing', Pi filters are not recommended for switching applications.

## Transient Suppression Pi Filter

The Transient Suppression Pi filter consists of a Pi filter with a transient suppressor at the input to the filter. The filter supplies the high frequency performance of the Pi filter with the added protection of the transient suppressor to protect the circuit from voltage spikes on the line.

## T Filter

The T filter consists of two inductive elements and one capacitive element. This circuit configuration presents a high impedance input from either end. It has similar filter performance to the Pi circuit configurations. It does not have the ringing characteristic of the Pi filter and can be used in switching applications.

## Multi-section Filter (Double T)

Spectrum's multi-element filters are designed for optimum insertion loss in circuits with a relatively low source and load impedance. These filters are also recommended in any application where a high degree of filtering is required. The unit utilizes an inductor input for the best compatibility with a MIL-STD-461 test setup (10  $\mu$ F feed-thru capacitor).

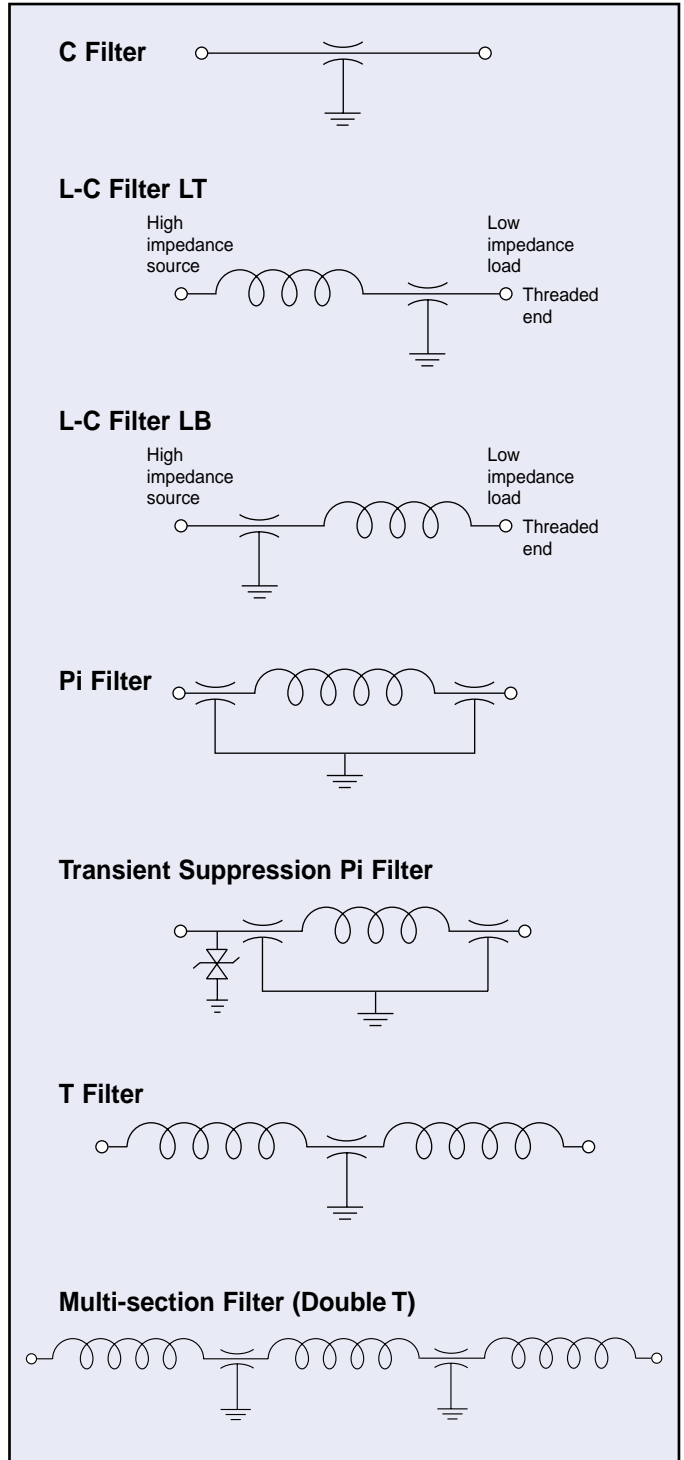

# Application Guidelines

## Insertion Loss Measurement

Insertion loss (IL) is a measure of the effectiveness of a filter. It is defined as the ratio of the voltage (E1) across the circuit load without the filter and the voltage (E2) across the load with the filter. Since insertion loss is dependent on the source and load impedance in which the filter is to be used, IL measurements are defined for a matched 50 ohm system. The insertion loss is measured in decibels (dB) and defined as follows:

$$IL \text{ (dB)} = 20 \log \left[ \frac{E1}{E2} \right]$$

## Circuit Impedance vs. Insertion Loss

In practical circuit applications the source and load impedances may be quite different from 50 ohms. If these impedances are known, Spectrum engineering can provide information on the expected Insertion Loss or an estimate can be made using the following formula:

$$IL \text{ (dB)} = 20 \log \left[ 1 + \frac{Z_s Z_l}{Z_t (Z_s + Z_l)} \right]$$

Where  $Z_s$  = Source impedance in ohms  
 $Z_l$  = Load impedance in ohms  
 $Z_t$  = Transfer impedance in 50 ohm system

Example:

1. System source and load impedances are 100 ohms and 600 ohms respectively.
2. Selected filter has insertion loss of 50 dB at 100 MHz in a 50 ohm system.
3. From the IL vs Transfer Impedance curve (right) the transfer impedance is 0.08 ohms.

$$4. IL = 20 \log \left[ 1 + \frac{100 \times 600}{0.08 (100+600)} \right]$$

$$= 20 \log 1072$$

$$= 61 \text{ dB}$$

Insertion Loss (dB)

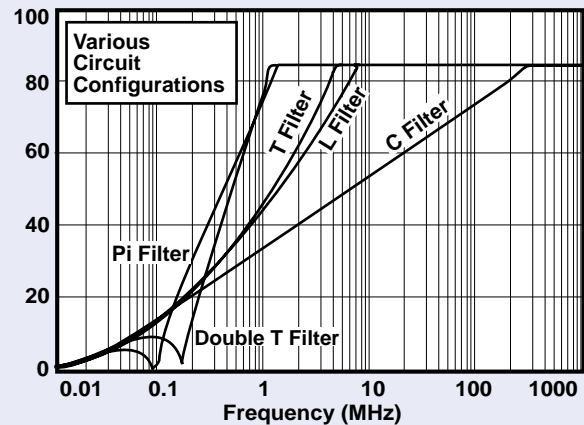
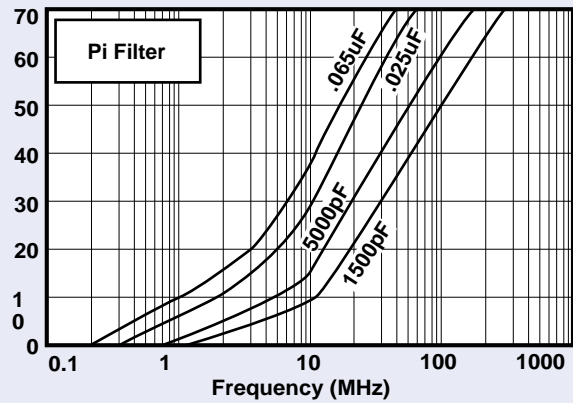
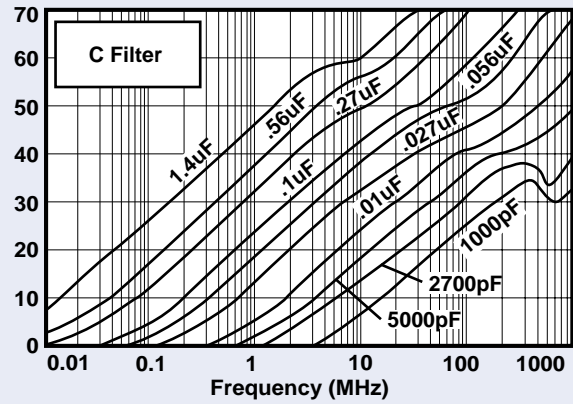

Transfer Impedance Graph

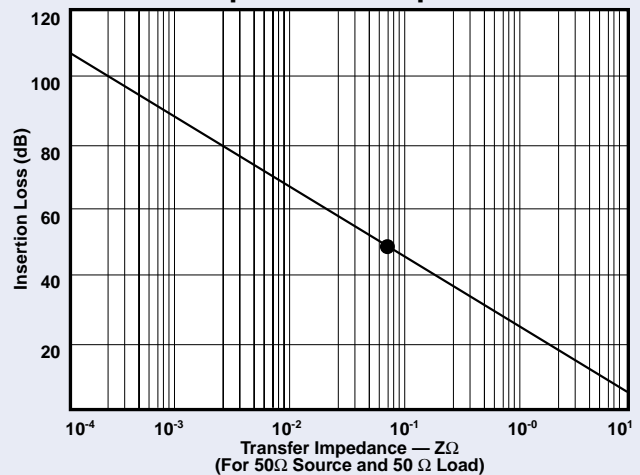

# Application Guidelines

## Surface Mount Filters

Surface mount filters are rated at currents up to 20 amps for achieving electromagnetic compatibility on high current printed circuit boards. These filters are available in feed-thru and Pi circuit configurations. Tape and reel packaging is available to enable pick and place equipment installation of this product, saving time and cost compared to thru-hole filters.

## Resin Sealed Filters

Resin sealed filters offer a wide variety of packages to accommodate your size and mounting requirements. Miniature solder-in (low profile) filters are constructed with a discoidal and are glass sealed on one end to provide hermeticity between compartments. Solder-in filters provide a compact, low cost Pi or C filter that can be soldered into a bulkhead. High current/high voltage bolt-in filters featuring current ratings up to 100 ADC or rated voltages up to 2500 VDC.

## Hermetically Sealed Case Filters

Glass seal filters are used where a rugged, hermetically sealed filter is required. They consist of discoidal capacitors with or without ferrite sleeves or wound inductors in 1/4-28 or 5/16-24 threaded cases. Through the use of discoidal capacitors and wound inductors, high capacitance and inductance values can be achieved. Hermetically sealed filters provide very high EMI filtering performance.

## Filtered Arrays

The filtered array product offers flexibility to customers in choosing an efficient and cost effective solution to solving EMC issues. The filtered array product line encompasses our filter plates and filtered terminal blocks. Filter plates involve multiple filter elements packaged into a metal ground plate. We offer both the patent pending Easy Mate® family of filter plates or traditional Bolt-in style plates. Standard filter plates are available in 0.100" or 2mm centers, with many other configurations possible.

## Filtered Connectors

Spectrum Control's filtered connectors offer the most complete selection of products in the industry. Our products range from standard D-subminiature filtered connectors to more complex circular and ARINC connectors. Custom solutions are available, and our engineering support team will work closely with your engineering staff to solve your EMC problems at the I/O interface.



## EMC Testing Services

Spectrum Control is a solutions-oriented EMC test corporation committed to effectively satisfying worldwide EMC standards for commercial and military equipment. Our EMC testing services offer you a flexible resource to assist in product development by identifying and correcting EMI susceptibility and/or emission problems.

Our commitment to our customers goes much further than any other EMI filtered power products manufacturer. Spectrum Control has a fully equipped EMC Test Laboratory and experienced engineering staff ready to solve your most demanding EMC challenges.

We can test your equipment, system or subsystem to various domestic and international regulatory standards, determine state of compliance, and develop the most compact and cost-effective solution. These services (EMC testing and compliance recommendations) are available for a modest daily fee. It is not uncommon for clients leave Spectrum Control's EMC Test Laboratory with a prototype in hand.

### State-of-the-art Testing

- Two test environments available: anechoic chamber and shielded room
- Baseline of device under test in ambient-free anechoic chamber
- Computer controlled pre-selected EMI receivers with quasi-peak detection accumulate data for displaying information in graphical or tabular formats
- Fiber optic coupled video cameras for dynamic test observation
- Computer generated test data reduces time and improves accuracy



### Testing Capabilities

#### MILITARY

MIL-STD-461 A/B/C/D/E and MIL-STD-1399

#### AUTOMOTIVE

SAE-J1113, SAE-J551

#### COMMERCIAL

FCC-Part 15

RTCA-DO-160 A/B/C

Boeing-16050-2

Bellcore-TR-NWT-001089

#### INTERNATIONAL

EN 55011 (CISPR 11)

EN 55014 (CISPR 14)

EN 55022 (CISPR 22)

IEC-1000-4-02 ESD

IEC-1000-4-03 RFI

IEC-1000-4-04 EFT

IEC-1000-4-05 Surge

IEC-1000-4-06 CI

# Filter Installation

## Threaded Style Filters

Filter Thread Size	Maximum Mounting Torque		Mounting Hole Dia.		Drill Size	
	in-lbs	Nm	(in)	(mm)	English	Metric (mm)
4-40	1.5	0.170	0.120	3.05	# 31	3.10
6-40	3	0.339	0.147	3.73	# 26	3.75
6-32	3	0.339	0.147	3.73	# 26	3.75
8-32	4	0.452	0.173	4.39	# 17	4.40
10-32	4	0.452	0.190	4.83	# 8	5.10
12-28	6	0.678	0.228	5.79	# 1	5.80
12-32	6	0.678	0.228	5.79	# 1	5.80
1/4-28 *	7	0.791	0.261	6.63	# G	6.70
5/16-24 *	7	0.791	0.323	8.20	# P	8.25
5/16-32	7	0.791	0.323	8.20	# P	8.25
3/8-32	9	1.017	0.386	9.80	# W	9.90

Note: For 5/8-24 and 7/16-28 please refer to the specific instruction noted on part drawings or see page 82 of the catalog.

- Exceeding recommended mounting torque may result in damage to the capacitor within the filter due to possible twisting or elongation of the case.
- For product without hex surfaces do not hold the filter with pliers or other gripping tools. Pressure exerted on the filter case may crack the ceramic capacitor element.
- Proper use of filters requires that the filter case be adequately grounded to form an effective path for the interference.

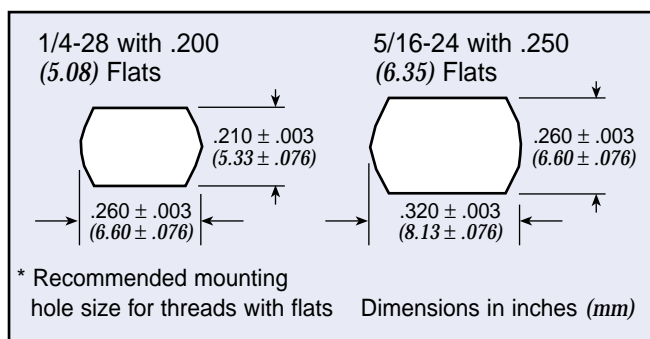

## Solder-in Style Filters

- A controlled temperature profile not exceeding 6°F (3°C) per second is recommended when soldering filters.
- When soldering to terminals of a filter, a heat sink should always be used adjacent to the body of the filter.
- 60-40 solder is recommended for installation of the filter into the chassis as well as soldering to the terminals. If a filter style without an eyelet is being soldered into a chassis, iron processes should be avoided and the recommended solder alloy is 60-38-2.
- Installation hole size for a solder-in filter should be 0.003-0.005" over the maximum tolerance of the minor diameter of the mounting portion of the eyelet with a ±0.002" tolerance.
- Machine/oven soldering 385-415°F (195-210°C) using a dwell and cycle time fast enough to reflow the solder and ramped to maintain less than 6°F/sec rate of change.

- For iron soldering to filter body, preheat components at 250-300°F (120-150°C), solder iron is recommended to be set at 500-550°F (260-290°C). The dwell on the solder joint should be less than 5 seconds. The time is dependent on the heat sinking provided by the chassis so a longer preheat may be required.

## Soldering to Filter Terminals

- Use a temperature controlled soldering iron with tip temperature of 525 ± 10°F (275 ± 5°C).
- Use an SN 63 RMA flux core solder.
- Make mechanical wire connection.
- Use heat sink next to filter body where possible.
- Clean soldering iron tip.
- Clip end of solder (remove 0.5") to expose flux for soldering.
- Apply soldering iron to wire/flag junction at wetted solder tip region of iron (Wetted Bridge Method). Immediately apply solder. Dwell time for soldering iron tip on product should be 3-5 seconds maximum.

# EMI/RFI Filter and Capacitor Performance Testing

The resin sealed and hermetically sealed filters shown in this section have been designed to meet the requirements of this test plan as applicable. Group I tests are typically performed on most product. Groups II, III and IV tests are performed per specification requirements.

The information shown can be used as a basis for filter specifications. (Contact factory for additional details if necessary.)

Test Group	Order of Test	Examination or Test	Test Method	Post Test Requirements
I	*1	Visual and Mechanical Examination		In accordance with applicable requirements.
	*2	Materials, Designs, Construction and Workmanship		
	*3	Physical Dimensions and Marking		
	*4	Seal	Method 112 <sup>†</sup> , Condition A	No leaks. Not applicable to resin sealed or solder-in products.
	*5	Capacitance	Method 305 <sup>†</sup> , 1KHz. 2.5 VRMS Max. 25°C	Within specified tolerance.
	*6	Dielectric Withstanding Voltage	Method 301 <sup>†</sup> , 2.5 times, DCWV, 5 seconds, 50 Ma max. charging current	No evidence of damage or breakdown.
	*7	Insulation Resistance	Method 302 <sup>†</sup> at DCWV, at 2 minutes 50 ma charging current	Greater than 1000 megohms or 100 ohm farads, whichever is less.
	*8	Voltage Drop	MIL-F-15733, Paragraph 4.6.8	Per applicable requirements.
	*9	Insertion Loss	MIL-STD-220, 3pc, sample only	Per applicable requirements.
II	1	Temperature Rise	MIL-F-15733, Paragraph 4.6.4	Per applicable requirements.
	2	Overload	MIL-F-15733, Paragraph 4.6.10	Per applicable requirements.
	3	Barometric Pressure	Method 105 <sup>†</sup> , Test Condition B hi-pot, (per method 301 <sup>†</sup> ) at 1.25 times DCWV	No evidence of damage or breakdown.
	4	Shock	Method 213 <sup>†</sup> , Test Condition I	No mechanical damage, Insulation resistance greater than 500 ohm farads, whichever is less.
	5	Vibration	Method 204 <sup>†</sup> , Test Condition B for Glass Seal, Condition D for Resin	No mechanical damage, Insulation resistance greater than 500 megohms or 50 ohm farads, whichever is less.
	6	Moisture Resistance	Method 106 <sup>†</sup>	Insulation resistance greater than 500 megohms or 50 ohm farads whichever is less.
III	1	Terminal Strength	Method 211 <sup>†</sup> , Test Condition A, 5 lbs.	No evidence of loosening or rupturing of terminal.
	2	Resistance to Soldering Heat	Method 210 <sup>†</sup> , Test Condition B, Depth of immersion 1/16 plus or minus 1/32	Insulation resistance greater than 500 megohms or 50 ohm farads whichever is less.
	3	Thermal Shock	Method 107 <sup>†</sup> Test Condition A -55°C to +125°C	Insulation resistance greater than 500 megohms or 50 ohm farads whichever is less.
	4	Immersion Cycling	Method 104 <sup>†</sup> Test Condition A	Insulation resistance greater than 500 megohms or 50 ohm farads whichever is less.
IV	1	Solderability (5pcs only)	Method 208 <sup>†</sup>	Per applicable requirements.
	2	Life	Method 108 <sup>†</sup> , Test Condition D with 125% rated voltage at maximum operating temperature	Filters shall meet all initial requirements except insulation resistance shall not be less than 50% of initial guaranteed value.

\* Acceptance tests typically performed on most products.

<sup>†</sup> Methods are from MIL-STD-202

# EMI/RFI Filter and Capacitor Performance Testing



## Reliability Levels

### Class B

Class B is outlined in MIL-F-28861 and is prescribed for most military/aerospace requirements. It is more stringent than MIL-F-15733 requiring 100% screening that includes thermal shock, voltage conditioning and x-ray.

Periodic Group B testing is performed on units selected at random from production lots.

## Class B Test Sequence Summary

### Group II

- Voltage and temperature limits of capacitance
- Insertion loss: @ 25°C, +125°C, -55°C
- AC voltage drop: (AC rated parts only)
- Temperature rise
- Barometric pressure
- Insulation resistance: @ 25°C and 125°C
- Overload: Apply 140% of rated current for 15 minutes
- Resistance to solvents

### Group III

- Vibration: 3 planes
- Vibration: (random) 3 planes
- Thermal shock: 5 cycles
- Seal test
- Resistance to solder heat
- Salt spray
- X-ray inspection

### Group IV

- Shick
- Terminal strength
- Thermal shock
- Seal
- X-ray inspection

### Group V

- Life test: 1000 hrs

### Group VI

- Solderability

### Class S

Class S is outlined in MIL-F-28861 and is prescribed for space/mission critical requirements. This reliability level includes all of the testing of Class B but also specifies complete baseline documentation for both capacitor manufacturing as well as filter manufacturing. Capacitor manufacturing is also controlled to MIL-C-123 which includes additional screening on the ceramic capacitors.

Group B testing is performed on every production lot.

## "R" level testing

"R" level screening is performed by Spectrum Control's Hi-Rel Laboratory as detailed below. Customers requiring special tests may order to their own specifications or simply order to level R and then note additions or deviations.

### "R" level test sequence

(100% testing unless otherwise specified)

- Thermal Shock: 5 cycles from -55°C to +125°C in accordance with MIL-STD-202, Method 107D, Condition A.
- Burn-in: 100 hours at 1.4x rated DC voltage, 125°C.
- Seal Test: MIL-STD-202, Method 112, Test Condition A. Hermetic seal parts only.
- Capacitance and Dissipation Factor: MIL-STD-202, Method 305, frequency 1kHz.
- Dielectric Withstanding Voltage: 2.5 times the rated DC voltage for 5 ± 1 second at 25°C, with 50 mA maximum charging current.
- Insulation Resistance: MIL-STD-202, Method 302, 125°C at rated DC voltage and room temperature (25°C). The 125°C requirement shall be 10% of the specified catalog IR at 25°C.
- DC Resistance: MIL-STD-202, Method 303.
- Insertion Loss Test — Sample per MIL-F-15733. At full rated load in accordance with MIL-STD-220. The minimum insertion loss shall be defined in the filter catalog.
- Visual and Mechanical: in accordance with MIL-F-15733.
- Marking: All filters which have successfully completed the test sequence shall be marked with an "R" in the second part of the number. For example, a standard SCI-2130-004 becomes SCI-R2130-004 and 9051-100-0000 becomes 9051-R100-0000, and 51-719-011 becomes 51-R719-011 after completion of the Hi-Rel Level "R" Test Sequence.

# Surface Mount Filters and Inductors



**ISO 9001**  
CERTIFIED



**SPECTRUM CONTROL INC.**  
A Control Products and Systems Company  
**Signal and Power Integrity Group**

# Surface Mount Filters and Inductors Selection Guide

## Three Terminal Chip EMI Filters

- SMD chips in EIA 0805, 1205, and 1806 body sizes
- Rated to 2 amps
- Capacitance values from 22 to 220,000 pF
- Several ceramic characteristics available
- Supplied on T&R for easy placement (Bulk also available)

Spectrum Control three terminal chips offer excellent filtering performance in high-current applications. These non-polar, surface-mountable chips offer superior ability to withstand transient voltages and surge. Other characteristics include exceptional solderability and resistance to solder heat.

*Three Terminal Chips . . . . . 48-51*  
*Three Terminal Chips Soldering Specifications . . . . . 52*  
*Three Terminal Chips Packaging Specifications . . . . . 53*

## LC Type Chips

- SMD chips in EIA 0805 and 1206 body sizes
- Available with cut-off frequencies from 10 MHz to 220 MHz
- Steep insertion loss (IL) curves

LC chips are ideal for use in high frequency signal lines as high-efficiency surface mount filters. These non-polar chip filters are effective over a wide range of frequencies and feature steep insertion loss characteristics. LC type chips are of monolithic construction utilizing dielectric and ferrite materials.

*LC Type Chips . . . . . 54-55*

## Square Surface Mount EMI Filters

- Square geometric for enhanced SMD soldering
- Pi circuits up to 10 amps
- Capacitance values up to 4000 pF
- Rated up to 100V DC

Square surface mount EMI filters are designed to filter EMI/RFI on crowded printed circuit boards at currents up to 10 amps. These filters eliminate the need for thru-hole filters, thereby giving the designer the ability to create an "RF fence" without using high-cost RF bulkheads. Spectrum square surface mount EMI filters are of high temperature construction and may be installed utilizing pick-and-place equipment.

*SSM Series . . . . . 56-59*

## High Current Power SMD EMI Filters

- PSM series
- Handles up to 20 amps
  - 20 amps for Feed-Thrus
  - 10 amps for Pi
- Rated up to 200V DC
- Capacitance values of 68 pF to 10,000 pF
- Superior performance in GHz applications

Spectrum Control high current power SMD EMI filters are the first surface mount filters designed to effectively filter EMI/RFI on printed circuit boards operating at currents up to 20 amps. These filters are of high temperature construction and offer superior high frequency noise suppression.

*PSM Series . . . . . 56-59*

## High Frequency Thru-Hole PCB Filters

- Thru-hole design available in two configurations
- Encapsulated capacitive and Ferrite to protect against environmental concerns

High frequency thru-hole PCB filters aid in meeting FCC and VDE requirements by providing EMI filtering for protection of low power digital circuits. These filters mount directly to printed circuit board, allowing the filter to be flow soldered with other components. Placement of one of these filters at the EMI problem source could eliminate the need for additional filtering at other circuit points.

*PCB Filters . . . . . 60*

## Surface Mount EMI Filters Three Terminal Chips

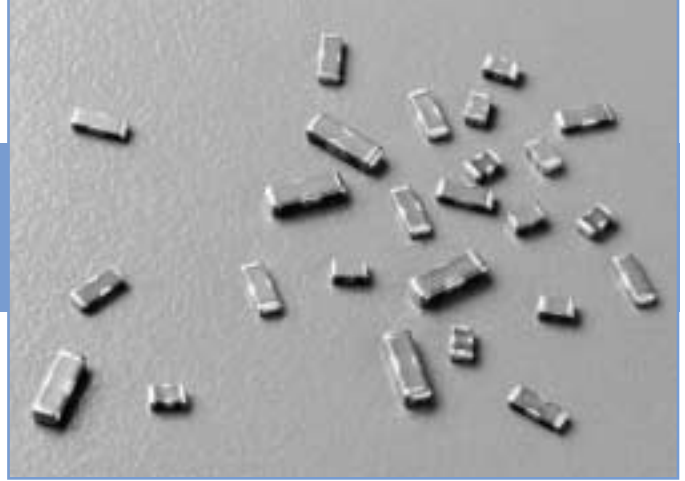

### Features

- Excellent performance in high current applications
- Non-polar, surface mountable
- Superior filtering characteristics
- Superb ability to withstand transient voltages and surge
- Offers exceptional solderability and resistance to solder heat
- Available in 0805, 1205 and 1806 body size
- Two amp current rating available

### Applications

- Cellular telephones and base stations
- Telecommunication equipment
- Industrial electronic interface or programmable controllers
- Electronic automotive equipment
- Computer and peripheral equipment

### Circuit Schematic

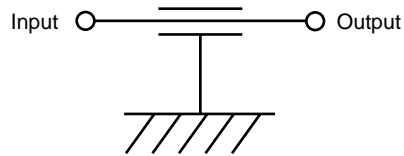

### Typical Electrical Characteristics

<i>Capacitance</i>	
<i>Range</i> .....	COG (NPO) 22 pF to 470 pF X7R 470 pF to 47,000 pF
<i>Capacitance</i>	
<i>Tolerance</i> .....	COG (NPO) ± 50%/-20% X7R ± 50%/-20%
<i>Temperature</i>	
<i>Coefficient</i> .....	COG (NPO) 0 ±30 ppm/°C, -55 to +125°C X7R +/-15%, -55 to +125°C
<i>Insulation</i>	
<i>Resistance</i> .....	up to 22,000 pF 10000 Megohms 47,000 pF 5000 Megohms
<i>DC</i>	
<i>Resistance</i> .....	0.4 Amp or less 0.3 ohm max. 1 Amp 0.08 ohm max. 2 Amp 0.04 ohm max.

## Surface Mount EMI Filters Three Terminal Chips

### Selection Guide

Part Number	Body Size	Capacitance (in picofarad)	Capacitance Tolerance	Temp. Charact.	Rated Voltage (Volts DC)	Rated Current (Amps DC)	IR (Megohms Min.)	DC Resistance (ohm Max.)	Operating Temp.
SF0805C220SBNC-*	0805	22	+50/-20%	COG	50	0.4	10,000	0.3	-55/+125°C
SF0805C470SBNC-*	0805	47	+50/-20%	COG	50	0.4	10,000	0.3	-55/+125°C
SF0805C101SBNC-*	0805	100	+50/-20%	COG	50	0.4	10,000	0.3	-55/+125°C
SF0805C221SBNC-*	0805	220	+50/-20%	COG	50	0.4	10,000	0.3	-55/+125°C
SF0805X471SBNC-*	0805	470	+50/-20%	X7R	50	0.4	10,000	0.3	-55/+125°C
SF0805X102SBNC-*	0805	1,000	+50/-20%	X7R	50	0.4	10,000	0.3	-55/+125°C
SF0805X222SBNC-*	0805	2,200	+50/-20%	X7R	50	0.4	10,000	0.3	-55/+125°C
<b>SF0805X223SBND-*</b>	<b>0805</b>	<b>22,000</b>	<b>+50/-20%</b>	<b>X7R</b>	<b>50</b>	<b>1.0</b>	<b>10,000</b>	<b>0.08</b>	<b>-55/+125°C</b>
SF1205C220SBNB-*	1205	22	+50/-20%	COG	50	0.3	10,000	0.3	-55/+125°C
SF1205C470SBNB-*	1205	47	+50/-20%	COG	50	0.3	10,000	0.3	-55/+125°C
SF1205C101SBNB-*	1205	100	+50/-20%	COG	50	0.3	10,000	0.3	-55/+125°C
SF1205C221SBNB-*	1205	220	+50/-20%	COG	50	0.3	10,000	0.3	-55/+125°C
SF1205X471SBNB-*	1205	470	+50/-20%	X7R	50	0.3	10,000	0.3	-55/+125°C
SF1205X102SBNB-*	1205	1,000	+50/-20%	X7R	50	0.3	10,000	0.3	-55/+125°C
SF1205X222SBNB-*	1205	2,200	+50/-20%	X7R	50	0.3	10,000	0.3	-55/+125°C
SF1205X223SBNB-*	1205	22,000	+50/-20%	X7R	50	0.3	10,000	0.3	-55/+125°C
<b>SF1205X473SBND-*</b>	<b>1205</b>	<b>47,000</b>	<b>+50/-20%</b>	<b>X7R</b>	<b>50</b>	<b>1.0</b>	<b>5,000</b>	<b>0.08</b>	<b>-55/+125°C</b>
SF1806C220SDNB-*	1806	22	+50/-20%	COG	100	0.3	10,000	0.3	-55/+125°C
SF1806C470SDNB-*	1806	47	+50/-20%	COG	100	0.3	10,000	0.3	-55/+125°C
SF1806C101SDNB-*	1806	100	+50/-20%	COG	100	0.3	10,000	0.3	-55/+125°C
SF1806C221SDNB-*	1806	220	+50/-20%	COG	100	0.3	10,000	0.3	-55/+125°C
SF1806C471SDNB-*	1806	470	+50/-20%	COG	100	0.3	10,000	0.3	-55/+125°C
SF1806X102SDNB-*	1806	1,000	+50/-20%	X7R	100	0.3	10,000	0.3	-55/+125°C
SF1806X222SDNB-*	1806	2,200	+50/-20%	X7R	100	0.3	10,000	0.3	-55/+125°C
SF1806X103SDNB-*	1806	10,000	+50/-20%	X7R	100	0.3	10,000	0.3	-55/+125°C
SF1806X223SDNB-*	1806	22,000	+50/-20%	X7R	100	0.3	10,000	0.3	-55/+125°C
<b>2 AMP FILTER SF1806Y224ZBNE-*</b>	<b>1806</b>	<b>220,000</b>	<b>+80/-20%</b>	<b>Y5V †</b>	<b>50</b>	<b>2.0</b>	<b>1,000</b>	<b>0.04</b>	<b>-25/+85°C</b>

**Bold Letter** = High Current Applications

-\* = Denotes Packaging Style. Replace with T for Tape and Reel or B for Bulk

† = Temperature Characteristic is +30/-80%

# Surface Mount EMI Filters Three Terminal Chips

## Insertion Loss (Per Mil Stand 220)

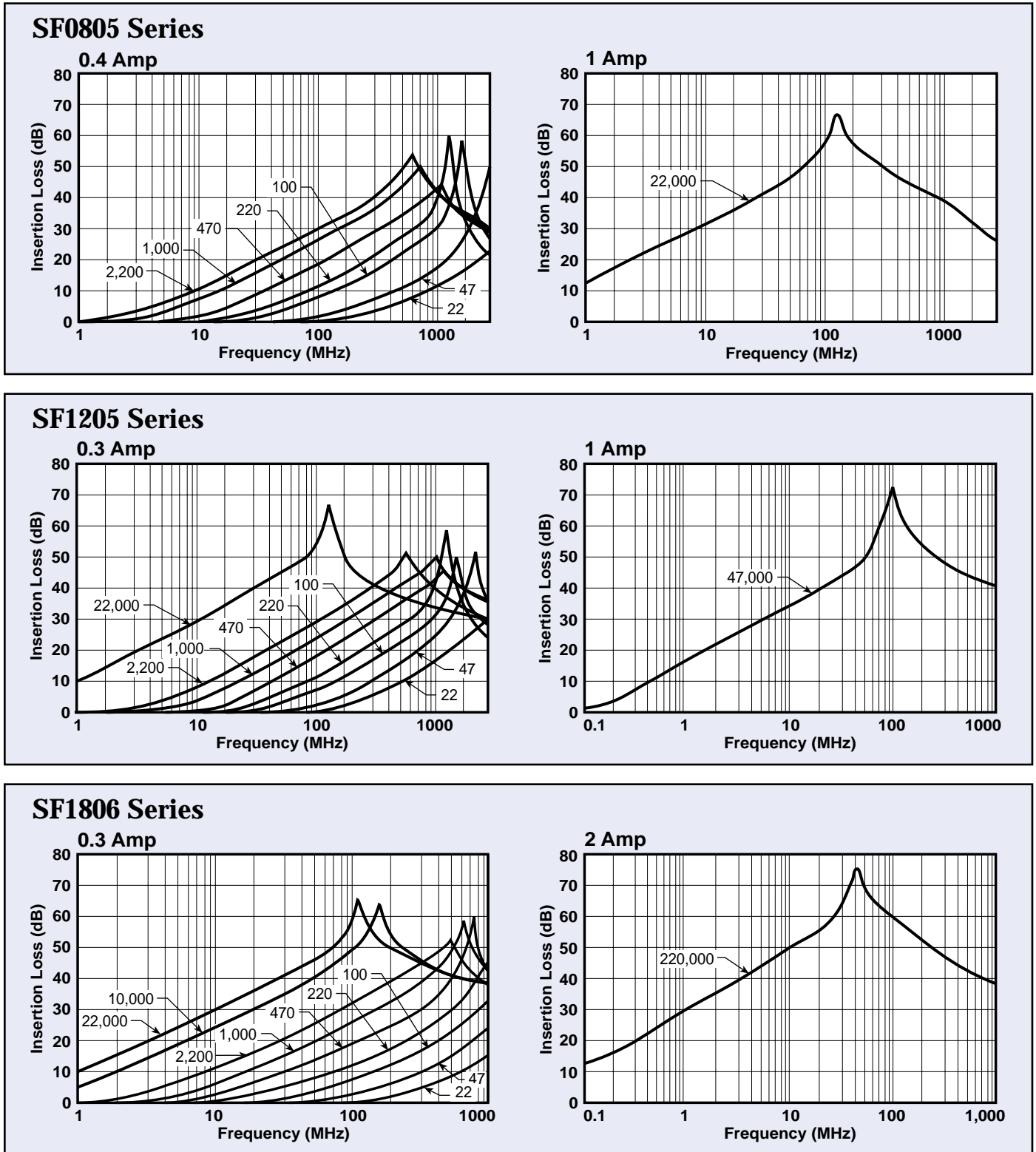

# Surface Mount EMI Filters Three Terminal Chips

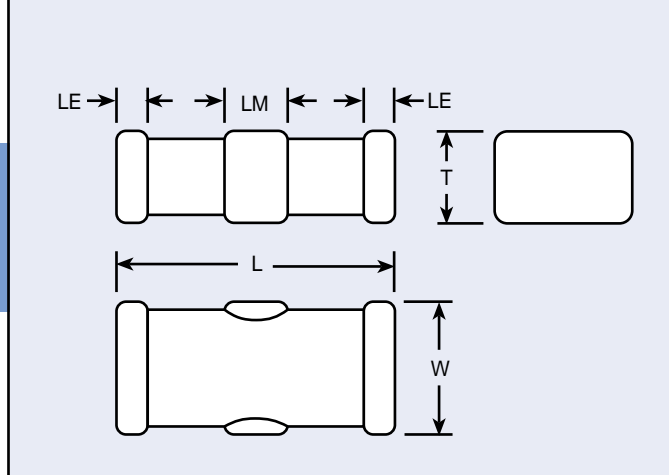

## Mechanical Dimensions

Dimensions in inches (mm)

Body Style/Size	Body Length (L)	Body Width (W)	Body Thickness (T)	End Terminal Length (LE)	Middle Terminal Length (LM)
SF0805	0.079 +/-0.008 (2.0 +/-0.2)	0.049 +/-0.008 (1.25 +/-0.2)	0.032 +/-0.008 (0.8 +/-0.2)	0.012 +/-0.008 (0.3 +/-0.2)	0.024 +/-0.008 (0.6 +/-0.2)
SF1205	0.126 +/-0.008 (3.2 +/-0.2)	0.049 +/-0.008 (1.25 +/-0.2)	0.028 +/-0.008 (0.7 +/-0.2)	0.016 +/-0.012 (0.4 +/-0.3)	0.043 +/-0.012 (1.1 +/-0.3)
SF1806	0.177 +/-0.012 (4.5 +/-0.3)	0.063 +/-0.012 (1.6 +/-0.3)	0.039 +/-0.012 (1.0 +/-0.3)	0.020 +/-0.012 (0.5 +/-0.3)	0.055 +/-0.012 (1.4 +/-0.3)

## Ordering Information

Example: **SF0805C221SBNCT**

This part number represents a three terminal chip with a body size of 0805 with a COG (NPO) dielectric. The capacitance is 220 pF with a capacitance tolerance of +50%/-20%. Voltage rating is 50 Volts DC. It has nickel barrier, solder plated terminations and a current rating of 0.4 Amp, (400 milliamps). The parts are taped and reeled.

SF	0805	C	221	S	B	N	C	T
Style	Size	Ceramic	Capacitance Code	Capacitance Tolerance	Rated Voltage (Vdc)	Termination	Current Rating	Packaging
SF	0805 1205 1806	C - COG X - X7R Y - Y5V	First Two Numbers are Significant, the Third Number Refers to Number of Zeroes	S - +50%/-20% Z - +80%/-20%	B - 50 D - 100	N - Ni Barrier, Solder Plated	B - 0.3 A C - 0.4 A D - 1 A E - 2 A	T - Tape and Reel B - Bulk

# Surface Mount EMI Filters Three Terminal Chips Soldering Specifications

## Soldering Instructions

### Reflow Soldering

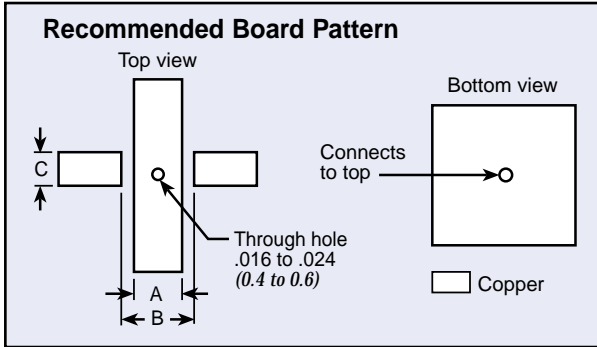

Board Pattern Dimensions in inches (mm)

Body Style/Size	Dimension		
	A	B	C
SF0805	0.024 (0.6)	0.059 (1.5)	0.039 (1.0)
SF1205	0.051 (1.3)	0.091 (2.3)	0.047 (1.2)
SF1806	0.079 (2.0)	0.138 (3.5)	0.051 (1.3)

### Reflow Soldering

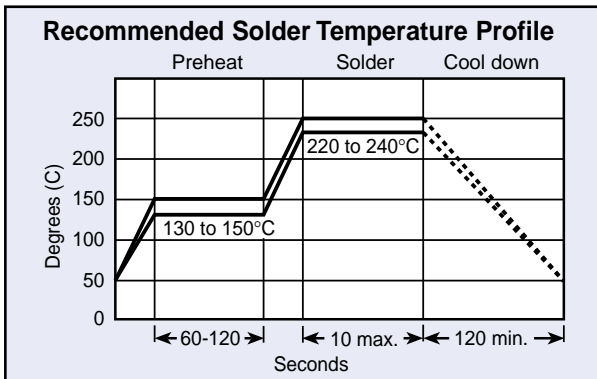

## General Soldering Notes

- High soldering temperatures and long soldering times can cause leaching of the termination and adversely affect adhesion. These conditions can also decrease capacitance value. Use the above recommended solder temperature cycle.
- Due to the mechanical characteristic of ceramic composition, aggressive thermal shock will degrade performance. Preheat the assembly before soldering using the above solder temperature profile as a guide.

### Flow Soldering

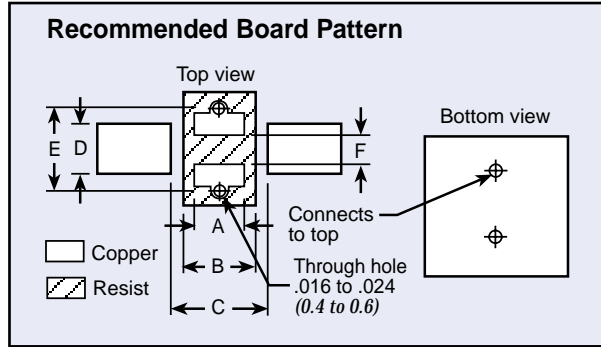

Board Pattern Dimensions in inches (mm)

Body Style/Size	Dimension					
	A	B	C	D	E	F
SF0805	0.024 (0.6)	0.031 (0.8)	0.059 (1.5)	0.039 (1.0)	0.087 (2.2)	0.024 (0.6)
SF1205	0.051 (1.3)	0.059 (1.5)	0.047 (1.2)	0.047 (1.2)	0.118 (3.0)	0.024 (0.6)
SF1806	0.059 (1.5)	0.079 (1.5)	0.138 (3.5)	0.051 (1.3)	0.118 (3.0)	0.024 (0.6)

### Flow Soldering

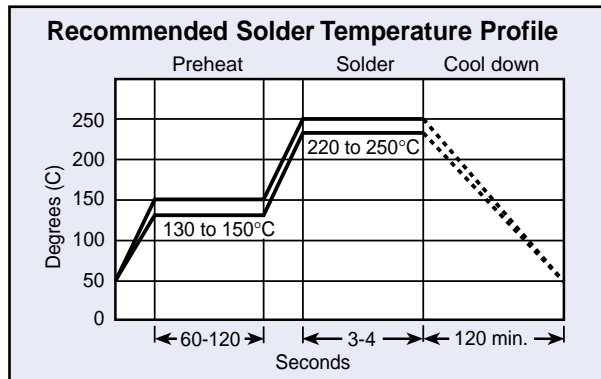

- Use mild flux (less than 0.2% by weight of Chlorine), preferable rosin based. If water soluble, wash thoroughly to assure all residue is removed from the underside of components.
- Ultrasonic Cleaning  
When using an ultrasonic cleaning method, the following range is recommended:  
Frequency: Not to exceed 28KHz  
Output Power: Not to exceed 20W/liter  
Cleaning Time: 5 minutes max

# Surface Mount EMI Filters Three Terminal Chips Packaging Specifications

## Package Quantities

Body Style/Size	Tape and Reel
SF0805	4,000 units/reel
SF1205	4,000 units/reel
SF1806	2,000 units/reel

## Package Information Paper Tape Dimensions SF0805 and SF1205 Bodies

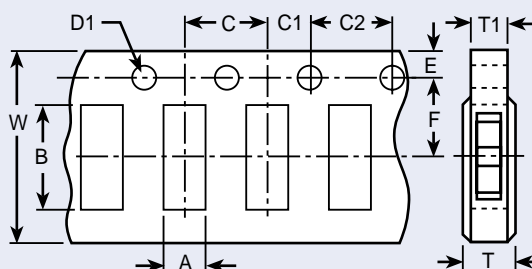

Dimensions in inches (mm)

Body Style/Size	Chip Cavity		Tape			Holes			Hole Diameter		Thickness	
	Length A	Width B	Width W	Center to End F	Indexing to End E	Center to Center C	Indexing to Center C1	Indexing to Center C2	Center D (Min.)	Indexing D1	Overall T (Max.)	Carrier Tape T1 (Max.)
SF0805	0.064	0.091	0.315	0.138	0.069	0.157	0.079	0.157	0.059		0.043	0.039
	+/-0.008 (1.62 +/-0.2)	+/-0.008 (2.3 +/-0.2)	+/-0.012 (8.0 +/-0.3)	+/-0.002 (3.5 +/-0.05)	+/-0.004 (1.75 +/-0.1)	+/-0.004 (4.0 +/-0.1)	+/-0.004 (2.0 +/-0.1)	+/-0.008 (4.0 +/-0.1)	+0.004/-0	(1.5 +/-0.1/-0)	(1.1)	(1.0)
SF1205	0.067	0.138	0.315	0.138	0.069	0.157	0.079	0.157	0.059		0.043	0.039
	+/-0.008 (1.70 +/-0.2)	+/-0.008 (3.5 +/-0.2)	+/-0.012 (8.0 +/-0.3)	+/-0.002 (3.5 +/-0.05)	+/-0.004 (1.75 +/-0.1)	+/-0.004 (4.0 +/-0.1)	+/-0.004 (2.0 +/-0.1)	+/-0.008 (4.0 +/-0.1)	+0.004/-0	(1.5 +/-0.1/-0)	(1.1)	(1.0)

## Plastic Reel Dimensions

Dimensions in inches (mm)

Body Style/Size	Diameter (Max.)	Width (Max.)
SF0805	7.00 (180)	0.46 (11.5)
SF1205	7.00 (180)	0.46 (11.5)
SF1806	7.00 (180)	0.61 (11.5)

## Package Information Tape and Reel Specification Plastic Carrier Tape Dimensions SF1806 Body

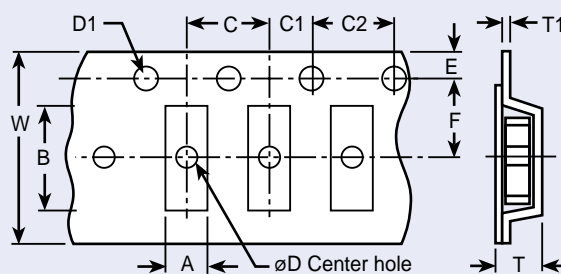

Dimensions in inches (mm)

Body Style/Size	Chip Cavity		Tape			Holes			Hole Diameter		Thickness	
	Length A	Width B	Width W	Center to End F	Indexing to End E	Center to Center C	Indexing to Center C1	Indexing to Center C2	Center D (Min.)	Indexing D1	Overall T (Max.)	Tape T1 (Max.)
SF1806	0.071	0.185	0.472	0.217	0.069	0.157	0.079	0.157	0.059	0.059	0.098	0.024
	+/-0.008 (1.80 +/-0.2)	+/-0.008 (4.70 +/-0.2)	+/-0.008 (12.0 +/-0.2)	+/-0.002 (5.5 +/-0.05)	+/-0.004 (1.75 +/-0.1)	+/-0.004 (4.0 +/-0.1)	+/-0.004 (2.0 +/-0.1)	+/-0.008 (4.0 +/-0.1)	+0.004/-0	(1.5 +/-0.1/-0)	(2.5)	(0.6)

# Surface Mount EMI Filters LC Type Chips

Surface Mount Filters & Inductors

## Features

- High efficiency EMI surface mount filter
- Non-polar, surface mountable
- Ideally suited for high frequency signal lines
- Steep insertion loss (IL) characteristics
- Effective over a wide range of frequencies
- Monolithic construction of dielectric and ferrite materials
- Available in the 0805 and 1206 body sizes

## Typical Electrical Characteristics

### Cut-off

Frequency Ranges . . . . . 10 MHz to 220 MHz

### Cut-off

Frequency Tolerances . . . . . ± 20%

Rated Voltage . . . . . 25 Volt

Rated Current . . . . . 100 milliamp

IR . . . . . 10 Megohms min.

Temperature Range . . . . . -25°C to +85°C

DC Resistance . . . . . 6 ohms max.

## Applications

- Cellular telephones and base stations
- Telecommunication equipment
- Industrial electronic interface or programmable controllers
- Computer and peripheral equipment
- Digital AV equipment such as TV, VCR and DVD
- Digital circuit equipment

## Package Quantities

Body Style/Size	Tape and Reel
LC0805	4,000 units/reel
LC1205	4,000 units/reel



## LC0805 Style

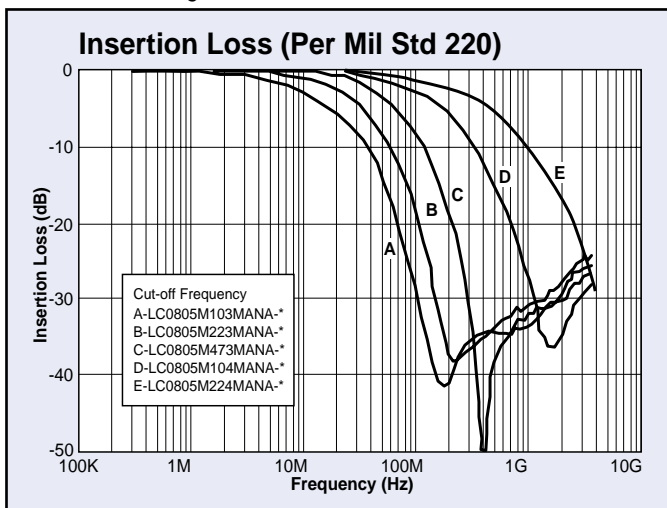

-\* Denotes packaging style, replace with T for tape and reel or B for bulk

## LC1206 Style

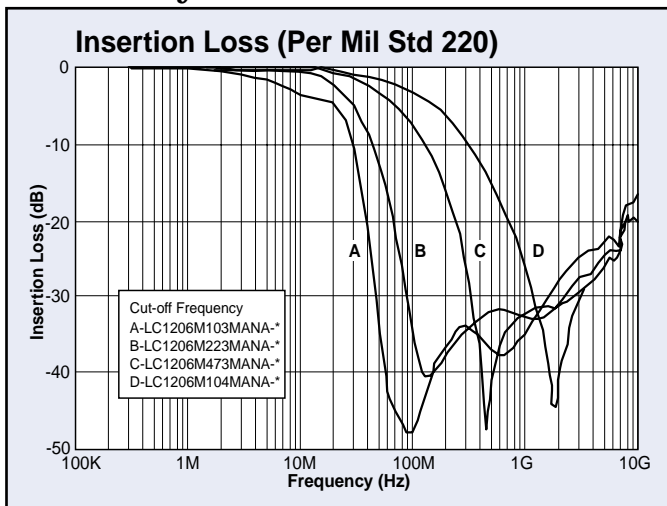

-\* Denotes packaging style, replace with T for tape and reel or B for bulk

# Surface Mount EMI Filters LC Type Chips

## Circuit Schematic

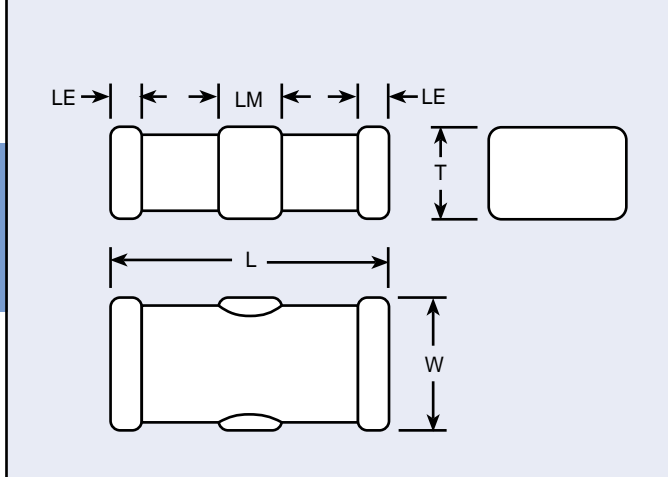
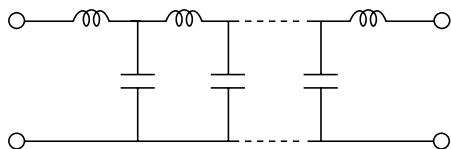

## Mechanical Dimensions

Dimensions in inches (mm)

Body Style/Size	Body Length (L)	Body Width (W)	Body Thickness (T)	End Terminal Length (LE)	Middle Terminal Length (LM)
LC0805	0.079 ± 0.008 (2.0 ± 0.2)	0.049 ± 0.008 (1.25 ± 0.2)	0.032 ± 0.008 (0.8 ± 0.2)	0.012 ± 0.008 (0.3 ± 0.2)	0.024 ± 0.008 (0.6 ± 0.2)
LC1206	0.126 ± 0.008 (3.2 ± 0.2)	0.058 ± 0.008 (1.60 ± 0.2)	0.0394 ± 0.008 (1.0 ± 0.2)	0.016 ± 0.012 (0.4 ± 0.3)	0.043 ± 0.012 (1.1 ± 0.3)

## Selector Guide

Part Number	Body Size	Cut-off Frequency	Cut-off Frequency Tolerance	Rated Voltage	Rated Current	I.R.	Temperature Range
LC0805M103MANA-*	0805	10 MHz	± 20%	25 V	10 mA	10 MΩ	-25°C ~ +85°C
LC0805M223MANA-*		22 MHz					
LC0805M473MANA-*		47 MHz					
LC0805M104MANA-*		100 MHz					
LC0805M224MANA-*		220 MHz					
LC1206M103MANA-*	1206	10 MHz	± 20%	25 V	10 mA	10 MΩ	-25°C ~ +85°C
LC1206M223MANA-*		22 MHz					
LC1206M473MANA-*		47 MHz					
LC1206M104MANA-*		100 MHz					

\* Denotes packaging style, replace with T for tape and reel or B for bulk

## Ordering Information

Example: **LC1206M223MANAT**

This part number represents an LC EMI filter chip with a body size of 1206. The cut-off frequency is 22 MHz with a tolerance of ± 20%, voltage rating is 25 Volts DC. It has nickel barrier, solder plated termination and a current rating of 0.1 Amp (100 milliamps). The parts are taped and reeled.

LC	1206	M223	M	A	N	A	T
Style	Size	Cut-off Frequency	Cut-off Tolerance	Rated Voltage	Termination	Rated Current	Packaging
LC	0805 1206	M103 = 10 MHz M223 = 22 MHz M473 = 47 MHz M104 = 100 MHz M224 = 220 MHz	M = ± 20%	A = 25 VDC	N = Ni Barrier, Solder Plated	A = 0.1 A (100 mA)	T = Tape and Reel B = Bulk

## Surface Mount EMI Filters PSM & SSM Series

PSM Series filters are the first surface mount components to effectively filter EMI/RFI on printed circuit boards operating at currents up to 20 Amps. SSM Series filters lend themselves for mounting on densely populated circuit boards where currents of 10 Amps or less are desired. By eliminating the need to use conventional thru-hole filters at these higher currents, it will be possible to create an “RF fence” without expensive RFI bulkheads. SSM & PSM filters can be installed with pick and place equipment, providing time and cost savings compared to installing thru-hole filters.



### Features

- High current up to 10 Amps (SSM) and 20 Amps (PSM)
- High temperature construction
- Excellent high frequency noise suppression
- Capacitance values up to 2,000pF (SSM) and 10,000pF (PSM)
- Superior performance in GHz applications
- Square mechanical geometry enhances SMT soldering

### Applications

- Power amplifiers
- High current bus lines
- Switching power supplies
- Signal and data lines in electronic equipment

# Surface Mount EMI Filters PSM & SSM Series

## PSM

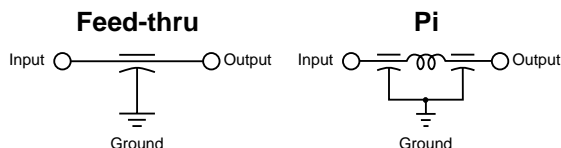

- Voltage Rating DC** . . . . . 200 VDC @ -55°C to +125°C
- Voltage Rating AC** . . . . . 125 VAC @ 60Hz
- DWV** . . . . . 700 VDC
- Current Rating** . . . . . 20 Amps (Feed-thru)  
10 Amps (Pi)
- Surge Current Capabilities** . . . . . 100 A for 1 second (Feed-thru)  
50 A for 1 second (Pi)
- Insulation Resistance** . . . . . 1.0 GOhms @ 25°C
- Dissipation Factor** . . . . . 4.0% maximum
- D.C.R.** . . . . . Max. .0005Ω, typ. .0002Ω

## SSM

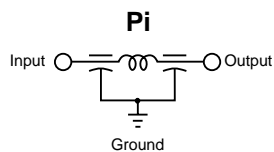

- Working Voltage** . . . . . 100 Vdc
- Test Voltage** . . . . . 250 Vdc
- Current** . . . . . Max. 10 amps
- Insulation Resistance** . . . . . Min. 10<sup>4</sup> MOhm
- Terminations** . . . . . Silver Ni-Tin plated
- Soldering Conditions** . . . . . Max. 250°C -5 sec.
- Marking** . . . . . None
- Packaging** . . . . . Bulk or tape and reel

**Note:** Insertion loss for SSM product not shown.  
For reference purposes use chart as follows:

SSM Value	PSM Value
101Z	100pF
501P	470pF
202P	1500pF

## Feed-thru Insertion Loss

### Typical SMT Applications

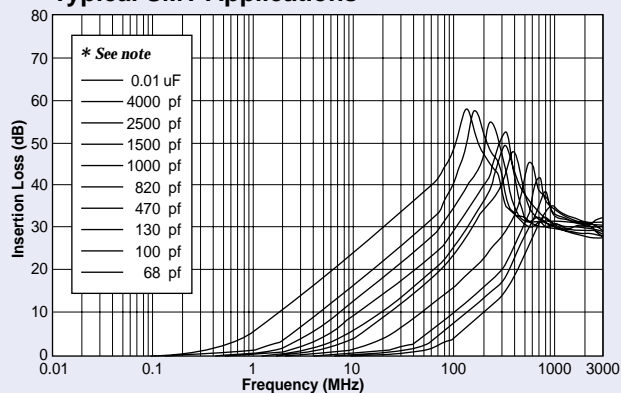

### Shielded or Partition Applications

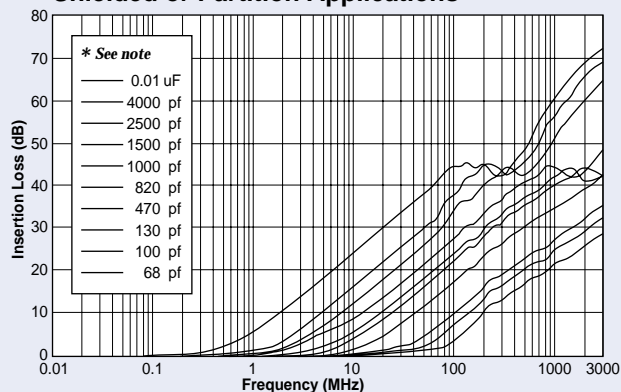

\* Capacitance values for insertion loss curves are displayed left to right in the order shown.

## Pi Insertion Loss

### Typical SMT Applications

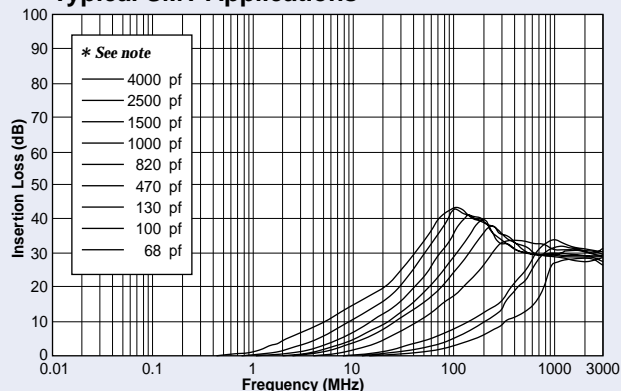

### Shielded or Partition Applications

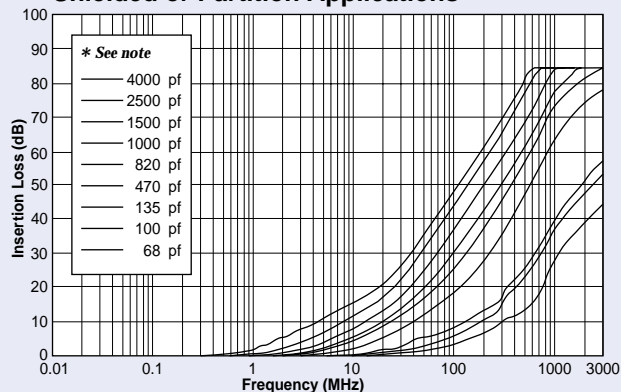

# Surface Mount EMI Filters PSM & SSM Series

## PSM Ordering Information

Example: **PSM4-402P-20T**

The part number shown represents a power surface mount feed-thru filter with a capacitance value of 4000 pF and capacitance tolerance of +80/-20%. The current rating of the part is 20 Amps and the packaging is tape and reel.

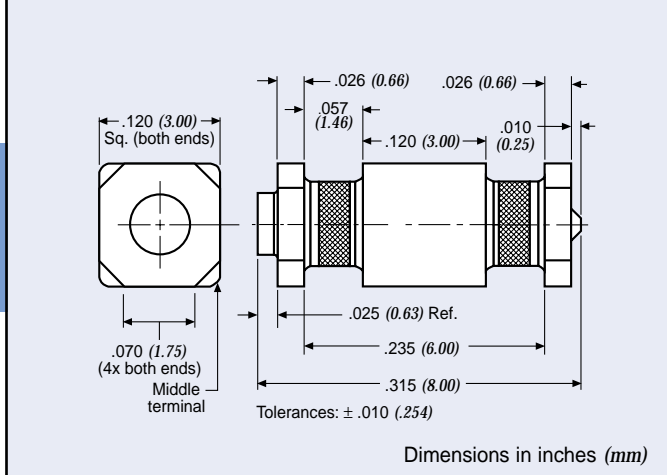

Surface Mount Filters & Inductors

<b>PSM</b> <hr/> Power Surface Mount	<b>4</b> <hr/> Circuit Configuration 1 - Pi 4 - Feed-thru	<b>402Z</b> <hr/> Capacitance	<b>20</b> <hr/> Current Rating 10 - 10 Amps (Pi) 20 - 20 Amps (Feed-thru)	<b>T</b> <hr/> Packaging T - Tape and reel packaging B - Bulk packaging	<b>0</b> <hr/> Tape and Reel 0 - 500 pieces 2 - 2,000 pieces <i>Note: Tape and reel packaging - 500 pieces (7") and 2,000 pieces (13")</i>
---	--	----------------------------------	--	--	--

Code	Value*	Tolerance
680M	68 pF	±20%
101M	100 pF	±20%
131P	130 pF	+100/-0%
471P	470 pF	+100/-0%
821M	820 pF	±20%
102M	1000 pF	±20%
152M	1500 pF	±20%
252P	2500 pF	+100/-0%
402P	4000 pF	+100/-0%
103Z**	.01 μF	+80/-20%

† Also available through Spectrum Control's authorized distributors.  
 € Also available through Spectrum Control's authorized European distributors/agents.  
 † PSM1-402Z-10T0 €  
 † PSM4-103Z-20T0 €  
 † PSM4-152M-20T0 €  
 † PSM4-402Z-20T0 €

\* Other capacitance values available as special order.  
 \*\* Available in Feed-thru circuit only.

## SSM Ordering Information

Example: **SSM1-101Z-05T**

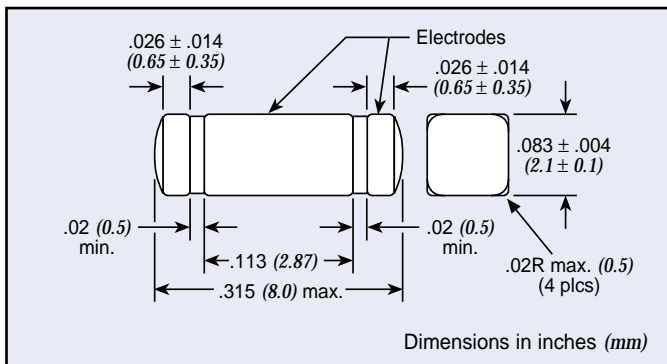

<b>SSM</b> <hr/> Style	<b>1</b> <hr/> Circuit Configuration 1 - Pi	<b>101Z</b> <hr/> Capacitance	<b>05</b> <hr/> Current Rating 05 - 5 Amps 10 - 10 Amps	<b>T</b> <hr/> Packaging T - Tape and reel packaging B - Bulk packaging	<b>1</b> <hr/> Tape and Reel 1 - 1,000 pieces 6 - 6,000 pieces <i>Note: Tape and reel packaging - 1,000 pieces (7") and 6,000 pieces (13")</i>
---------------------------	---	----------------------------------	--	--	--

Code	Value	Tolerance
101Z	100 pF	+80%/-20%
501P	500 pF	GMV
152P	1500 pF	+100%/-0%
202P	2000 pF	GMV
402E	4000 pF	±25%

† Also available through Spectrum Control's authorized distributors.  
 € Also available through Spectrum Control's authorized European distributors/agents.  
 † SSM1-152P-05-T1 €

# Surface Mount EMI Filters PSM & SSM Series

## Technical Notes

- Soldering recommendations supplied upon request
- Reflow temperature limit is 250°C
- Unit weight is approximately 0.4 grams
- Tape and reel packaging available for automated assembly

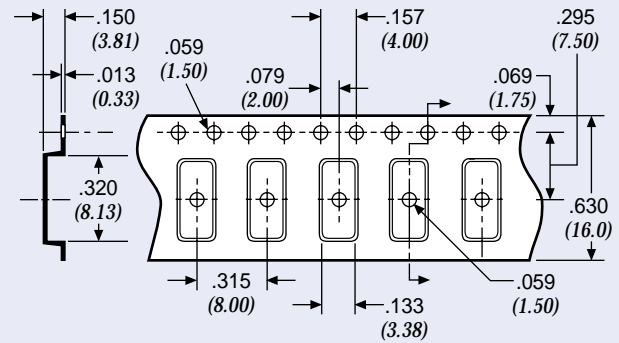

## PSM Tape and Reel Packaging

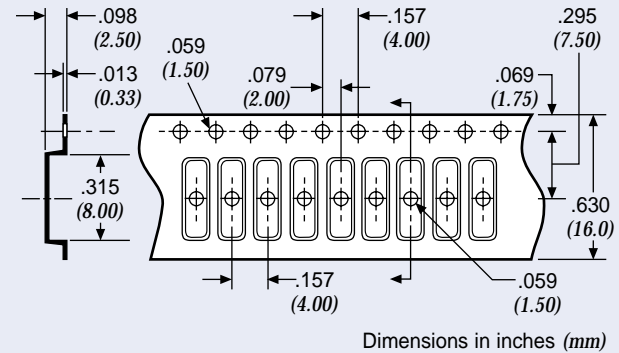

## SSM Tape and Reel Packaging



## PSM

-  Solder paste pattern
-  Recommended pad, must be able to support continuous signal current

X = 0.350" minimum for 1 oz. copper (0.036 mm thickness)  
 X = 0.200" minimum for 2 oz. copper (0.071 mm thickness)  
 For low current (10 Amp or less)  
 X = 0.130" minimum for 1 oz. copper (0.036 mm thickness for 10 Amp and 0.5 oz. copper - 0.018 mm thickness for 5 Amp or less)

Dimensions in inches (mm)

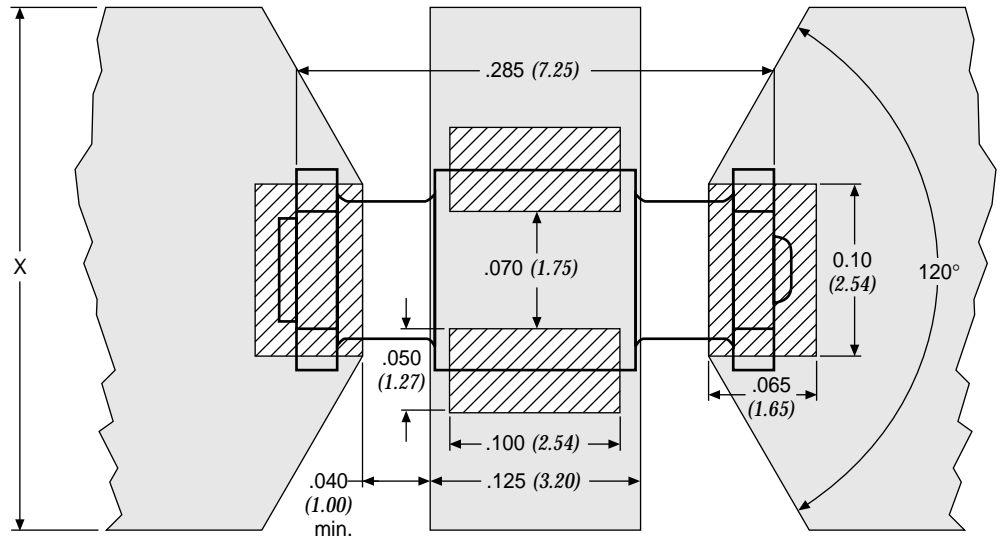

## SSM

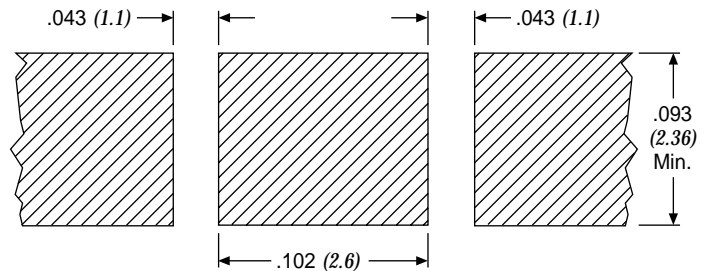

# Thru-hole Filters High Frequency PCB Filters

Surface Mount Filters & Inductors

The economical High Frequency PCB Filter offers electrical characteristics which allow many devices to meet most government and industry specifications for EMI control, while providing good electrostatic discharge protection.

A lossy ferrite filter with a center ground lead is terminated within the filter's thermoset epoxy body.

The High Frequency PCB Filter offers savings three ways. First is the low cost of the filter assembly. Second is the economy of installation. Three silver plated leads are inserted into holes in a printed circuit board which has a ground path circuit, for conventional flows-soldering with other components. No special mounting plate or brackets are needed and when the holes are placed as recommended in a .062 (1.57mm) thick board, no lead trimming is required. Elimination of hand soldering provides opportunities for improved quality in addition to applied-cost benefits.

A third savings results from placing a filter at the source of an EMI problem, potentially eliminating the need for additional filtering at other points in the circuit.

## Features

- Provides EMI filtering to protect low power digital circuits - helps equipment meet FCC and VDE specifications
- Mounts directly to printed circuit board with no bracket or plate for lower applied costs - can be flow soldered with other components
- Encapsulated for environmental protection
- Mounts on PCB to begin filtering at the source of the problem
- Built-in standoffs permit cleaning or coating under the filter

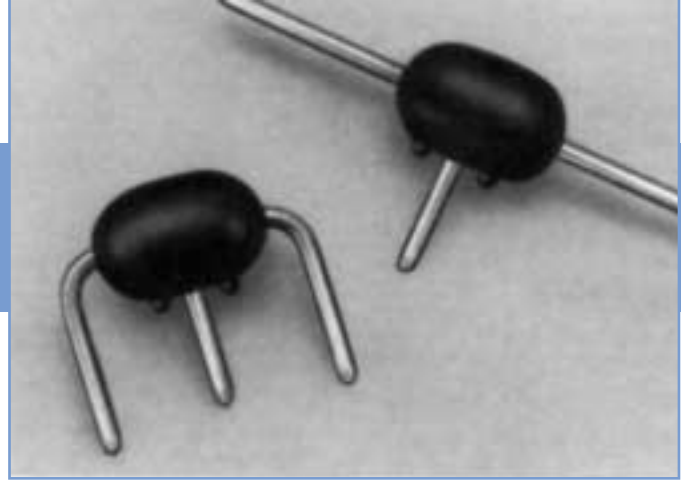

## Typical Electrical Characteristics

<i>Current</i> . . . . .	Max. 10A DC; 0.3A RF
<i>Operating Voltage</i> . . . . .	Max. 50 VDC, -25°C +85°C
<i>Capacitance</i> . . . . .	800 pF min.
<i>Dissipation Factor</i> . . . . .	0.1 Max.
<i>Dielectric Withstanding Voltage</i> . . . . .	125 VDC for 5 seconds
<i>Insulation Resistance</i> . . . . .	Min. 100 MegOhms at 100 VDC for 2 minutes and 25°C
<i>Direct Current Resistance</i> . . . . .	0.002 ohms Max.
<i>Minimum No-Load Insertion Loss</i> . . . . .	Per MIL-STD-220 at 25°C; PCB mounted, 50 ohm strip line
	3dB @ 8 MHz
	10dB @ 25 MHz
	15dB @ 50 MHz
	20dB @ 100 MHz-1GHz

## Preformed to Recommended Mounting Configuration Part Number 842448-2

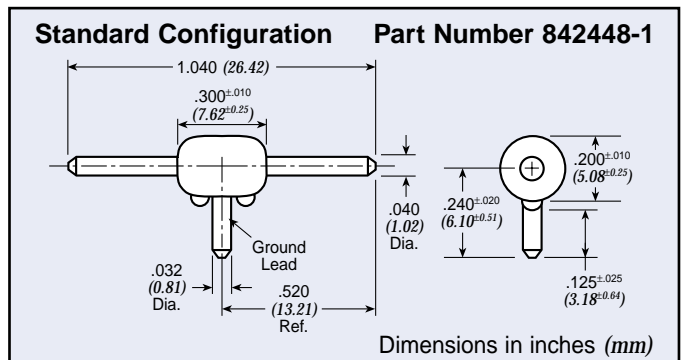
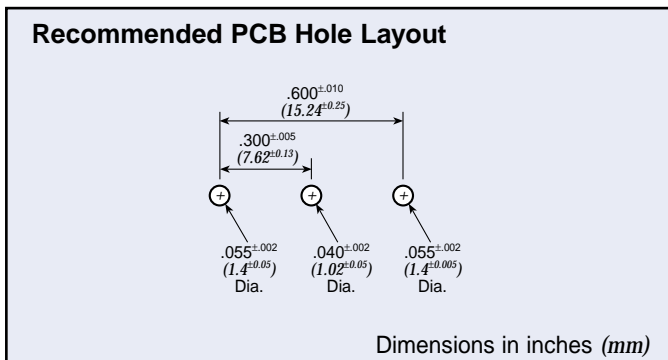
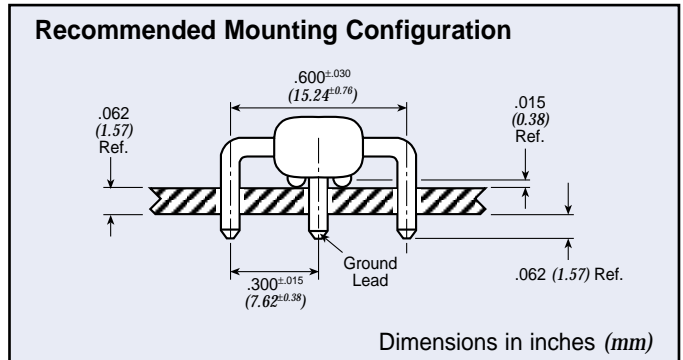

# Low Pass EMI Filters

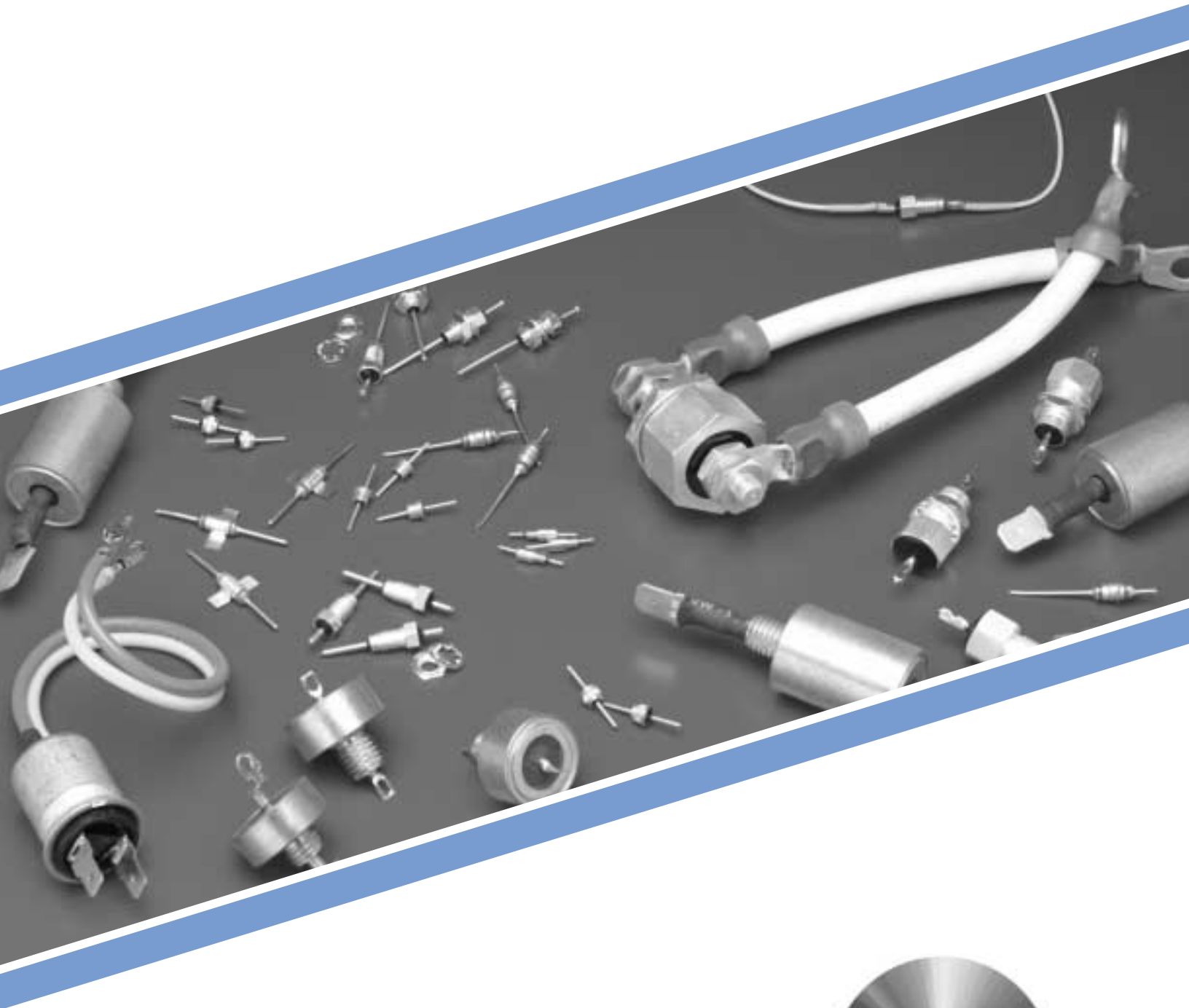

**ISO 9001**  
CERTIFIED



**SPECTRUM CONTROL INC.**  
A Control Products and Systems Company  
**Signal and Power Integrity Group**

**Other Key**

Pages	Pages
Filter Installation .....	16
Performance Testing.....	17-18
Value Added Filter Assemblies .....	100
Military Cross Reference .....	237-239

# Low Pass Filter Selection Guide

## MLFT Filters

- Performance through the GHz range
- Standard and custom mechanical packages available
- Transient voltage & surge protection available in some packages
- Available in multiple line packages

Motor Line Feed-Thru Technology (MLFT) is an innovative new line of filters designed to be a flexible, low cost solution to EMI (RF) noise issues. This product can be used in a variety of applications requiring high capacitance at lower voltages with the option of custom designed, easy to retro fit mechanical packaging.

*MLFT Filters* . . . . . 63

## Solder-in Filters

- Small size to allow effective use of space
- Voltage ratings to 750 VDC
- Multiple circuit configurations: C & Pi standard L circuit also available
- High temperature construction to prevent reflow during installation
- MIL-F-15733 QPL and MIL-C-11015 (CK99) filters available

Solder-in filters are ideal for use in critical areas where space does not allow use of mounting tools or hardware. The solder-in feature also allows installation in unison with other board mounted components. Primarily used in filtering signal/data lines and AC power lines.

*Solder-in Filters*

C . . . . .	64-65
Pi . . . . .	66-67
Miniature Solder-in Filters. . . . .	68

## Resin Sealed Bolt-in Filters

- Wide range of sizes: 4-40 thread through 5/16-24 thread
- Voltage ratings to 500 VDC/220 VAC
- MIL-F-15733 QPL filters available
- Multiple circuit configurations: C, L and Pi
- Metric Threaded filters available
- Spec-Spin and Spec-Mini Press filters

These filters are easily mounted in a tapped hole or thru-hole with supplied nut and lock-washer. The rugged case with resin seals at both ends provides excellent environmental protection. Primarily used in filtering signal/data lines and DC power lines. The Spec-Mini Press and Spec Spin Filters are ideal for use where solder is undesirable. Each offers easy filter substitution and are for use in microwave applications and other high frequency applications.

*Spec Mini-Press 9900 Series* . . . . . 69

*Spec Spin Filters* . . . . . 70

*Resin Sealed Bolt-in Filters*

4-40 . . . . .	71-73
6-32 . . . . .	74
6-40 . . . . .	74
8-32 . . . . .	75-76
10-32 . . . . .	77
12-28/32 . . . . .	78-80
5/16-24, 5/16-32 . . . . .	81

## High Current/High Voltage Resin Sealed Filters

- Current ratings up to 100 Amps
- Continuous voltage ratings up to 2500 VDC/240 VAC
- U.L. 1459 recognized and CSA C22.2 certified versions available
- Rugged bolt-in style for easy installation

High current filters are ideal for use in high current 5 volt logic buss, but also can be used for +/-48 VDC telephone rack buss, high current switch mode power supplies and DC charging systems. High voltage filters find use in high voltage power supplies and applications requiring U.L. Hi-Pot.

*High Voltage Filters*

25 Amp . . . . .	82-83
------------------	-------

*UL/CSA Filters*

50 Amp . . . . .	82-83
100 Amp . . . . .	82-83

## Hermetically Sealed Case Filters

- Popular .375/.410" and .690" case diameters
- Voltage ratings from 50 VDC to 400 VDC/240 VAC
- Filter configurations available: C, L, Pi, T and double T
- MIL-F-15733 and MIL-F-28861 QPL filters available

This series of filters features hermetic glass seals and high EMI filtering performance. They are excellent for critical applications that demand high reliability in the toughest environmental conditions and provide broadband high performance EMI filtering from 10 KHz to over 10 GHz.

Case Dia.	Filter	
.375 .410	C . . . . .	85
	L . . . . .	86-90
	Pi . . . . .	91-92
	Transient Suppression	
	Pi . . . . .	92
	T . . . . .	93
.690	TT . . . . .	94
	C . . . . .	95
	L . . . . .	96-97
	Pi . . . . .	98
	T . . . . .	99

## MLFT Filters

Motor Line Feed-Thru Technology (MLFT) is an innovative new line of filters designed to be a flexible, low cost solution to EMI (RF) noise issues.

The product was originally developed to solve the filtering needs of DC motors, allowing them to pass the stringent standards that govern these motors in various industries they are used. Although this product was developed with the DC motors in mind, it can be used in almost any application that requires high capacitance at lower voltages with the option of custom designed, easy to fit mechanical packaging.

By utilizing our vast experience in designing, testing products at our on-site lab, and manufacturing integrated filtering products; we can quickly and economically design an easy to use solution to any EMC issue.

With easy installation in mind, our feed-thru packages are designed to be placed at the product's interface to the outside world at the low impedance ground — where filtering is optimized. Thus eliminating the need for complex PC boards that are required when trying to incorporate surface mount components and boards into a system.

### Features

- Performance through the GHz range
- Standard and custom mechanical packages available
- Transient voltage & surge protection available in some packages
- Available in multiple line packages

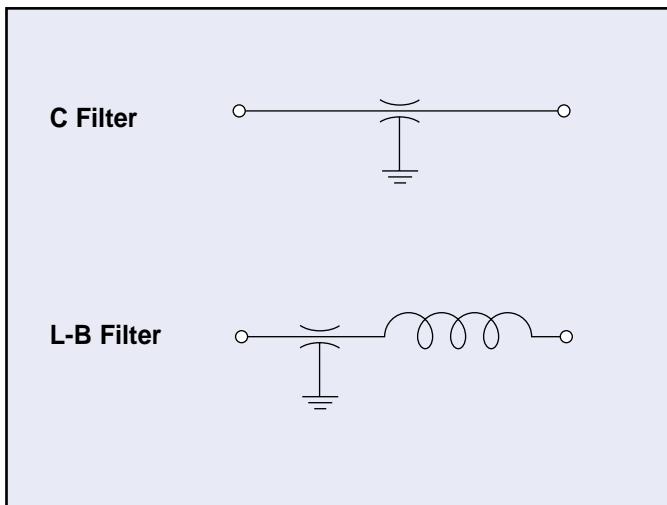

# Solder-in Filters



Solder-in filters are ideal for use in critical areas where space does not allow use of mounting tools or hardware. The solder-in feature also allows installation in unison with other board mounted components. Primarily used in filtering signal/data lines and DC power lines.

## Features

- Small size to allow effective use of space
- Voltage ratings to 750 VDC
- Multiple circuit configurations: C, L & Pi available
- High temperature construction to prevent reflow during installation
- MIL-F-15733 QPL versions available

Low Pass Filters

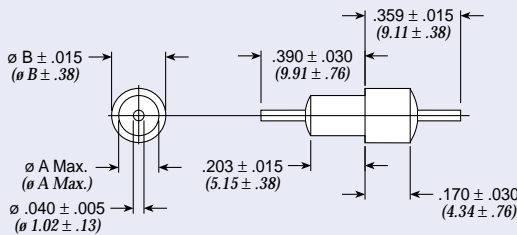

Figure 1

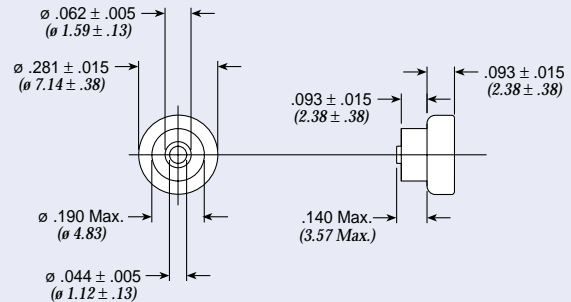

Figure 2

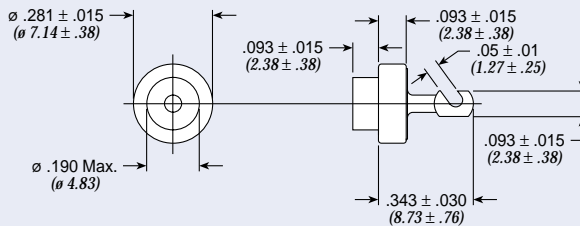

Figure 3

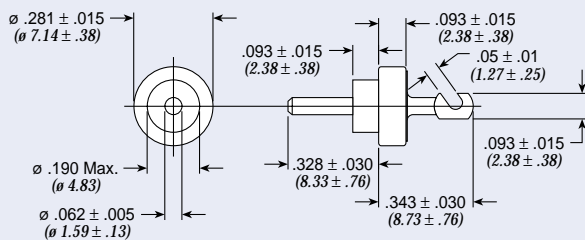

Figure 4

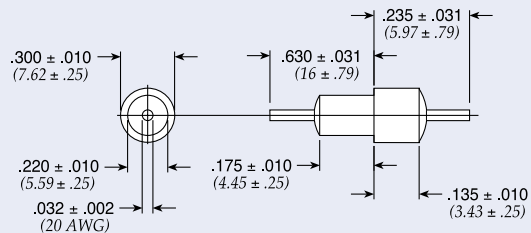

Figure 5

Dimensions in inches (mm)

# Solder-in Filters

## Solder-in C Circuit

Part Number	See Pg. 64 for Fig.	A		B		Rated Voltage 125°C DC	I Amp	Cap*	Minimum Insertion Loss (dB)						
		In	(mm)	In	(mm)				1 MHz	10 MHz	30 MHz	100 MHz	300 MHz	1 GHz	10 GHz
54-786-003	1	0.156	(3.96)	0.203	(5.16)	50	10	0.30 $\mu$ F	32	47	54	60	66	70	20
54-785-002	1	0.125	(3.18)	0.170	(4.32)	100	10	0.05 $\mu$ F (min)	16	33	41	45	48	50	50
54794002X5R101M	4	—	—	—	—	250	25	100 pF $\pm$ 20%	—	—	—	—	10	20	20
54803004X5R101M	3	—	—	—	—	250	25	100 pF $\pm$ 20%	—	—	—	—	10	20	20
54802002X5R101M	2	—	—	—	—	250	25	100 pF $\pm$ 20%	—	—	—	—	10	20	20
† 54794002X5R471M	4	—	—	—	—	250	25	470 pF $\pm$ 20%	—	—	—	12	22	25	25
† 54803004X5R471M	3	—	—	—	—	250	25	470 pF $\pm$ 20%	—	—	—	12	22	25	25
54802002X5R471M	2	—	—	—	—	250	25	470 pF $\pm$ 20%	—	—	—	12	22	25	25
† 54802002X5V102P	2	—	—	—	—	250	25	1000 pF	—	—	—	15	25	35	40
† 54803004X5V102P	3	—	—	—	—	250	25	1000 pF	—	—	—	15	25	35	40
† 54794002X5V102P	4	—	—	—	—	250	25	1000 pF	—	—	—	15	25	35	40
† 54-785-047	5	—	—	—	—	750	10	1000pF	—	4	—	20	25	35	40

† Also available through Spectrum Control's authorized distributors.

\* Tolerances are +100/-0% unless noted.

# Solder-in Filters

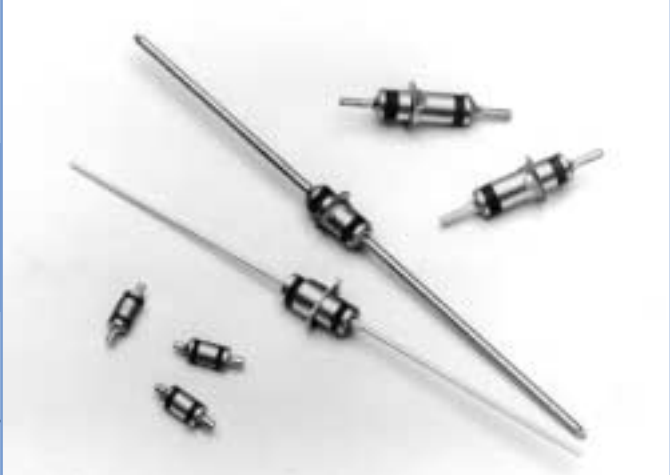

## Solder-in Pi Circuit

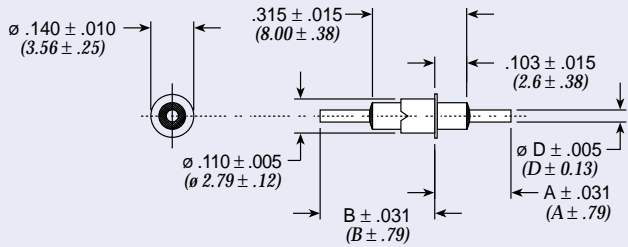

Figure 1

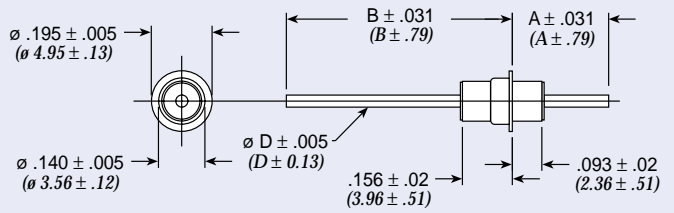

Figure 2

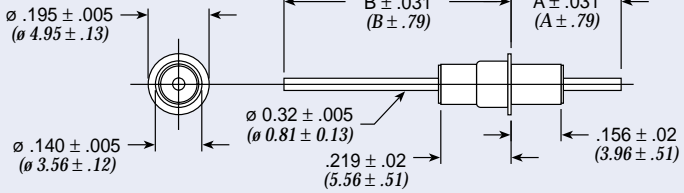

Figure 3

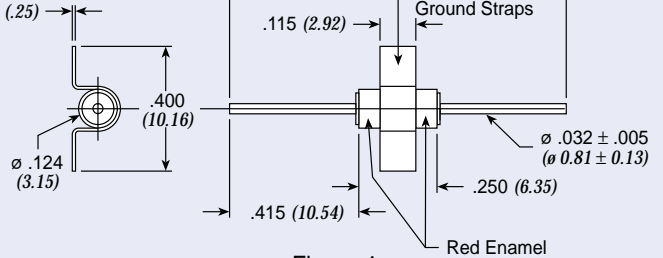

Figure 4

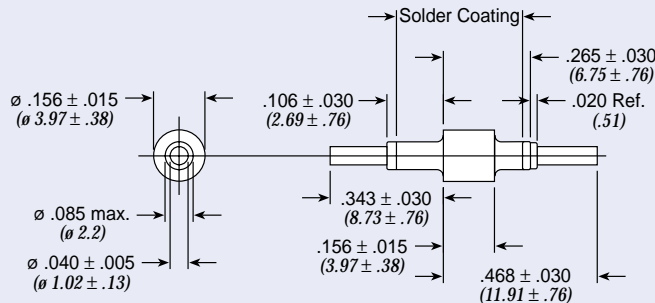

Figure 5

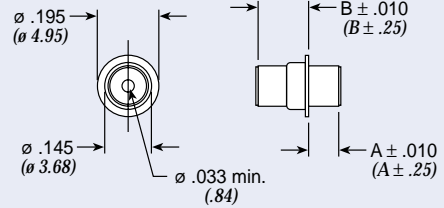

Figure 6

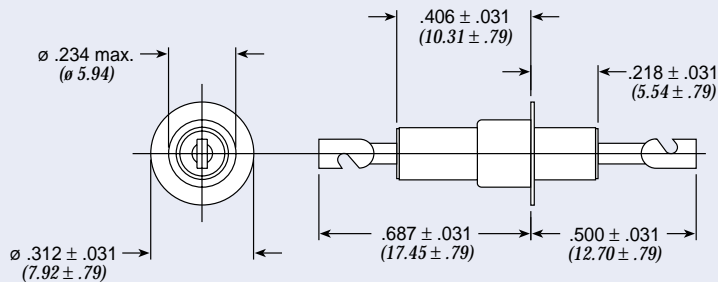

Figure 7

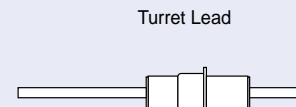

Figure 8

Dimensions in inches (mm)

# Solder-in Filters

## Solder-in Pi Circuit

Part Number	M15733 MIL Number	See Pg. 66 for Fig.	A		B		D		Rated Voltage 125°C		I Amp	Min Cap	Minimum Insertion Loss (dB)						
			In	(mm)	In	(mm)	In	(mm)	DC	AC			1 MHz	10 MHz	30 MHz	100 MHz	300 MHz	1 GHz	10 GHz
			1223-012	—	1	0.240	(6.10)	0.360	(9.14)	0.040			(1.02)	50	—	15	3000 pF	—	7
51-703-013*	/62-0003	3	0.312	(7.92)	0.469	(11.91)	0.032	(0.81)	70	—	10	1500 pF	—	5	12	50	50	65	65
51-750-309*	/62-0004	2	0.268	(6.81)	0.780	(19.81)	0.032	(0.81)	70	—	10	0.012 µF	5	22	50	70	70	65	65
† 1234-000* €	—	2	0.257	(6.53)	0.780	(19.81)	0.032	(0.81)	70	—	10	0.012 µF	5	25	50	70	70	70	70
51-749-304	—	4	—	—	—	—	—	—	70	—	10	0.012 µF	5	25	50	70	70	65	65
1234-001	—	4	—	—	—	—	—	—	70	—	10	0.012 µF	5	25	50	70	70	65	65
† 51-750-301*	—	2	0.250	(6.35)	0.780	(19.81)	0.032	(0.81)	70	—	10	0.012 µF	5	25	50	70	70	70	70
† 1233-000* €	—	3	0.312	(7.92)	0.780	(19.81)	0.032	(0.81)	70	—	10	0.022 µF	7	35	60	70	70	70	70
† 51-750-302*	—	3	0.312	(7.92)	0.780	(19.81)	0.032	(0.81)	70	—	10	0.022 µF	7	25	60	70	70	70	70
51-750-313	/51-0002	3	0.312	(7.92)	0.780	(19.81)	0.032	(0.81)	70	—	10	0.022 µF	7	25	60	70	70	70	70
† 51-723-303	—	5	—	—	—	—	—	—	200	—	10	1300 pF	—	5	15	30	45	55	55
51-713-010	/62-0002	1	1.140	(28.96)	1.277	(32.44)	0.032	(0.81)	200	—	10	1500 pF	—	5	12	45	50	70	70
† 1251-001 €	—	1	1.109	(28.17)	1.206	(30.63)	0.032	(0.81)	200	—	10	1500 pF	—	5	15	40	50	70	70
51-703-001*	—	3	0.312	(7.92)	0.406	(10.31)	0.032	(0.81)	200	—	10	1500 pF	—	8	17	45	65	70	70
† 1203-050 €	—	3	0.312	(7.92)	0.406	(10.31)	0.032	(0.81)	200	—	10	1500 pF	—	5	15	45	50	70	70
51-703-012*	—	3	0.312	(7.92)	0.406	(10.31)	0.032	(0.81)	200	140	10	1500 pF	—	3	15	45	50	70	70
51-713-002	—	1	1.103	(28.01)	1.212	(30.78)	0.032	(0.81)	200	—	10	1500 pF	—	5	12	40	70	70	70
1214-029	—	2	0.288	(7.31)	0.780	(19.81)	0.032	(0.81)	200	—	10	1750 pF	—	5	15	50	60	60	60
† 1214-007 €	—	6	0.093	(2.36)	0.157	(3.99)	—	—	200	—	10	1750 pF	—	5	15	35	50	60	60
51-707-002*	—	2	0.288	(7.31)	0.780	(19.81)	0.032	(0.81)	200	—	10	1750 pF	—	8	17	50	65	70	70
† 1214-001*	—	2	0.288	(7.31)	0.780	(19.81)	0.032	(0.81)	200	—	10	1750 pF	—	5	15	50	50	60	60
† 51-707-006*	/33-0001	2	0.288	(7.31)	0.780	(19.81)	0.032	(0.81)	200	90	10	1750 pF	—	5	15	50	50	60	60
51-707-007	/33-0002	2	0.288	(7.31)	0.780	(19.81)	0.032	(0.81)	200	90	10	1750 pF	—	5	15	50	50	60	60
51-707-026	/66-0001	6	0.288	(7.31)	0.157	(3.99)	—	—	200	—	10	1750 pF	—	5	15	35	50	50	50
† 51-750-322	—	2	1.123	(28.52)	1.347	(34.21)	0.040	(1.02)	200	—	10	3000 pF	—	7	25	50	65	65	65
51-723-301	—	5	—	—	—	—	—	—	200	—	10	5500 pF	—	14	30	55	65	65	65
51-703-007*	/51-0001	3	0.312	(7.92)	0.406	(10.31)	0.032	(0.81)	200	200	10	5500 pF	—	15	30	55	65	70	70
† 1204-050 €	—	7	—	—	—	—	—	—	500	—	25	3000 pF	—	8	25	50	65	70	70
51-704-002	/40-0001	7	—	—	—	—	—	—	500	350	25	3000 pF	—	7	25	55	65	70	70

\* Denotes parts with turret on one end per Figure 8.  
 † Also available through Spectrum Control's authorized distributors.  
 € Also available through Spectrum Control's authorized European distributors/agents.

# Miniature Solder-in Filters

These filters are ideal for microwave applications such as attenuators and oscillators, and perform well in high impedance circuits where large capacitance values are not practical.

## Features

- Miniature size to allow effective use of space
- Standard capacitance values from 5pF to .030μF
- Voltage ratings to 200 VDC/115 VAC 0–400 Hz
- Hermetically sealed on one end allows for thru-hole sealing between compartments
- High temperature construction meets MIL-F-28861 solderability and resistance to soldering heat requirements
- Available in MIL-C-11015 versions — see page 239
- Gold plating compatible with gold bonding techniques

## Marking

Color dot standard as follows:

- 101 Green – 100pF
- 272 Red – 2700pF
- 501 Brown – 500pF
- 502 Blue – 5000pF
- 102 Purple – 1000pF
- 153 Pink – 15000pF
- 122 White – 1200pF
- 000 None – 10pF max

## Miniature Solder-in C Circuit

Part Number*	Figure	Rated Voltage 125°C		I Amp	Min Cap	Minimum Insertion Loss (dB)						
		DC	AC			1 MHz	10 MHz	30 MHz	100 MHz	300 MHz	1 GHz	10 GHz
SCI-9900-153	1	50		5	0.015 μF	7	25	30	40	40	60	60
SCI-9900-303	1	50		5	0.030 μF	10	30	35	45	50	55	55
† SCI-9910-272	1	100		5	2700 pF	—	10	18	25	33	40	50
† SCI-9910-502	1	100		5	5000 pF	—	15	20	30	35	45	55
SCI-9900-000	1	200		5	10 pF max.	—	—	—	—	—	10	10
† SCI-9920-101	1	200	115	5	100 pF	—	—	—	3	10	20	28
† SCI-9920-501	1	200	115	5	500 pF	—	—	—	15	22	35	40
† SCI-9920-122	1	200	115	5	1200 pF	—	5	10	20	28	35	45

\* For reverse glass seal add an "R" to the end of the part number (SCI-9900-153R).

† Also available through Spectrum Control's authorized distributors.

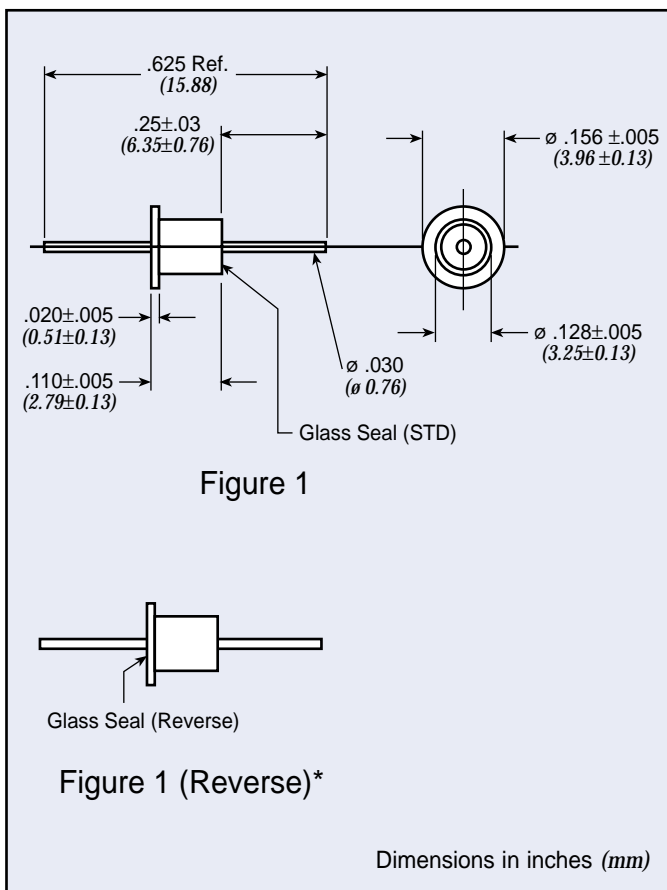

# Spec Mini-Press 9900 Series

This new knurled filter is designed to be pressed into place and create a reliable mechanical bond. This feature makes it an excellent selection for applications where soldering is undesirable. Suitable plating is available that allows gold bonding to the terminals.

## Applications

These filters are ideal for microwave and RF applications such as attenuators, synthesizers, and oscillators. They perform well in high impedance circuits where large capacitance values are not practical.

## Installation

- .136" to .137" (3.45-3.48mm) diameter hole
- Hole must be free of all insulating materials.
- Installation tool must have a hole of sufficient depth and diameter to accept the terminal of the filter.
- Installation force must be applied gradually and smoothly until the flange of the filter is seated against the receiving part (request installation instructions).

## Mechanical Specifications

- Installation* . . . . . Press-in
- Plating* . . . . . Gold
- Seal* . . . . . Glass sealed on one end,  
resin sealed on the other end
- Termination Options* . . . . . Plating suitable for gold  
bonding
- Operating Temperature* . . . . -55°C to +125°C

## Circuit Schematic

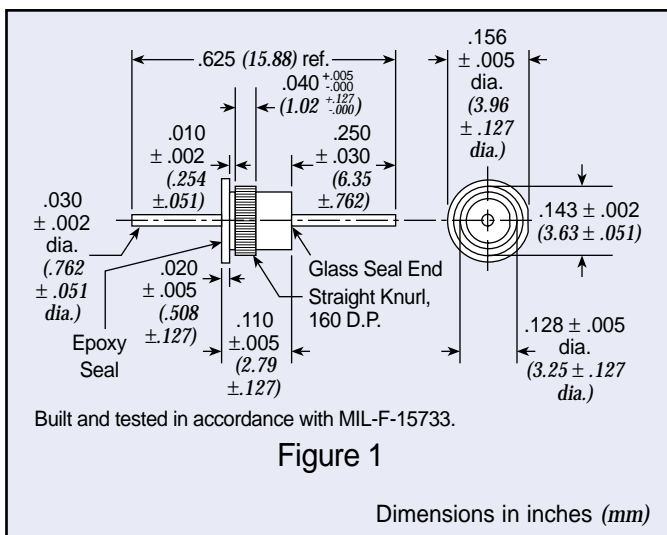
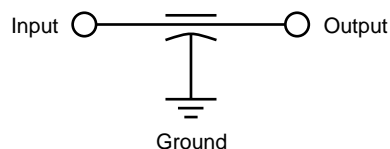

## Insertion Tool

Part Number: SCI-9925-200

Part Number	Figure	Rated Voltage	I Amp	Cap	Minimum Insertion Loss (dB)						
		125°C			1 MHz	10 MHz	30 MHz	100 MHz	300 MHz	1 GHz	10 GHz
† SCI-9925-153	1	50	5	0.015 µF +100%/-0%	7	25	30	40	40	60	60
† SCI-9925-303	1	50	5	0.030 µF +100%/-0%	10	30	35	45	50	55	55
† SCI-9925-502	1	100	5	5000 pF +100%/-0%	—	15	20	30	35	45	55
† SCI-9925-000	1	200	5	10 pF max.	—	—	—	—	—	10	10
† SCI-9925-101	1	200	5	100 pF +100%/-0%	—	—	—	3	10	20	28
† SCI-9925-501	1	200	5	500 pF +100%/-0%	—	—	—	15	22	35	40
† SCI-9925-122	1	200	5	1200 pF +100%/-0%	—	5	10	20	28	35	45

† Also available through Spectrum Control's authorized distributors.



# Resin Sealed Bolt-in Filters



These filters are easily mounted in a tapped hole or thru-hole with supplied nut and lock-washer. The rugged case with resin seals at both ends provides excellent environmental protection. Primarily used in filtering signal/data lines and DC power lines.

## Features

- Wide range of sizes: 4-40 thread through 5/16-24 thread
- Voltage ratings to 500 VDC/220 VAC (400 Hz)
- MIL-F-15733 QPL filters available
- Multiple circuit configurations: C, L and Pi
- Metric threaded filters available, consult factory

## 4-40 C Circuit

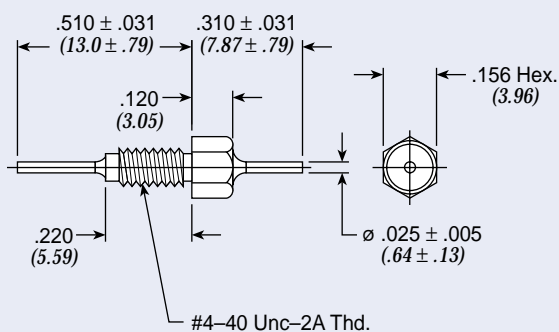

Figure 1

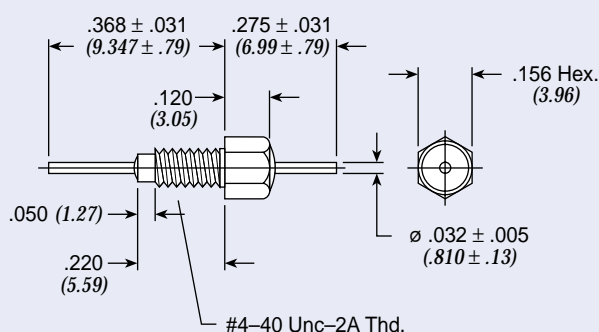

Figure 2

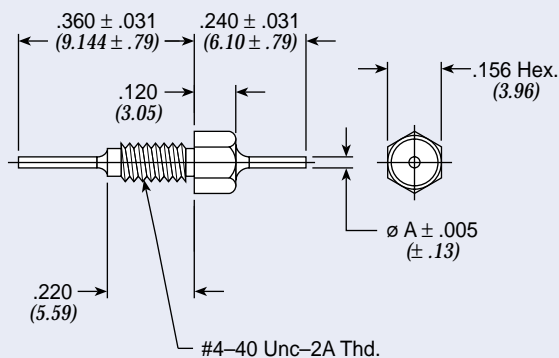

Figure 3

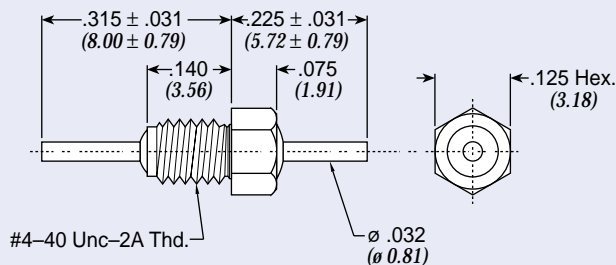

Figure 4

Dimensions in inches (mm)

# Resin Sealed Bolt-in Filters

## 4-40 C Circuit

Low Pass Filters

Part Number	See Pg. 71 for Fig.	Rated Voltage 125°C		I Amp	Min Cap	A		Minimum Insertion Loss (dB)							
		DC	AC			In	(mm)	1 MHz	3 MHz	10 MHz	30 MHz	100 MHz	300 MHz	1 GHz	10 GHz
† SCI-9110-100	3	50	—	10	10 pF	0.032	(0.81)	—	—	—	—	—	—	10	10
† 9900-381-6004	2	50	—	10	5000 pF	—	—	—	—	15	22	30	35	45	55
9900-381-6026	2	50	—	10	0.031 µF	—	—	12	20	25	35	40	45	55	60
† 9900-381-6006	2	50	—	10	0.045 µF	—	—	14	22	30	40	45	50	55	60
† 54-790-023	1	100	—	10	0.056 µF	—	—	15	24	34	41	45	50	60	60
† 54790001X5F101M	1	100	—	10	100 pF ± 20%	—	—	—	—	—	—	—	10	20	25
54-790-019	1	100	—	10	2700 pF	—	—	—	—	9	18	27	33	35	35
9900-381-6013	2	100	—	10	2700 pF	—	—	—	—	10	18	25	33	40	50
54-790-020	1	100	—	10	5600 pF	—	—	—	—	15	24	33	37	40	40
SCI-9112-273	3	100	—	3	0.027 µF	0.016	(0.41)*	10	20	30	37	45	45	55	60
SCI-9110-273	3	100	—	10	0.027 µF	0.020	(0.51)	10	20	30	37	45	45	55	60
54-790-022	1	100	—	10	0.027 µF	—	—	10	20	30	37	45	50	55	60
† SCI-9112-503	3	100	—	3	0.05 µF	0.016	(0.41)*	15	24	35	41	45	50	60	60
SCI-9110-503	3	100	—	10	0.05 µF	0.020	(0.51)	15	24	35	41	45	50	60	60
54-862-001	4	200	—	10	10 pF	—	—	—	—	—	—	—	—	10	10
54-862-002	4	200	—	10	100 pF	—	—	—	—	—	—	3	10	20	28
54-862-003	4	200	—	10	1000 pF	—	—	—	—	—	—	15	25	35	40
† 9900-381-6020	2	200	—	10	100 pF	—	—	—	—	—	—	3	10	20	28
SCI-9122-101	3	200	115	3	100 pF	0.016	(0.41)*	—	—	—	—	—	10	20	20
SCI-9120-101	3	200	115	10	100 pF	0.020	(0.51)	—	—	—	—	—	10	20	20
9900-381-6021	2	200	—	10	500 pF	—	—	—	—	—	—	15	20	35	40
† SCI-9122-102	3	200	115	3	1000 pF	0.016	(0.41)*	—	—	—	11	20	28	28	68
† SCI-9120-102	3	200	115	10	1000 pF	0.020	(0.51)	—	—	—	11	20	28	28	68
† 9900-381-6022	2	200	—	10	1200 pF	—	—	—	—	5	9	20	28	35	45
SCI-9122-502	3	200	115	3	5000 pF	0.016	(0.41)*	—	—	15	24	33	37	40	50
SCI-9120-502	3	200	115	10	5000 pF	0.020	(0.51)	—	—	15	24	33	37	40	50
SCI-9122-103	3	200	115	3	0.01 µF	0.016	(0.41)*	—	12	20	29	38	45	50	55
SCI-9120-103	3	200	115	10	0.01 µF	0.020	(0.51)	—	12	20	29	38	45	50	55
9900-381-6005	2	200	—	10	0.015 µF	—	—	7	9	20	29	35	45	50	60
† 54-790-018	1	300	—	10	1000 pF	—	—	—	—	9	20	28	28	68	68
† 54-790-021	1	300	—	10	0.01 µF	—	—	—	9	20	29	38	45	50	50

\* Tinned, steel leads.

† Also available through Spectrum Control's authorized distributors.

# Resin Sealed Bolt-in Filters

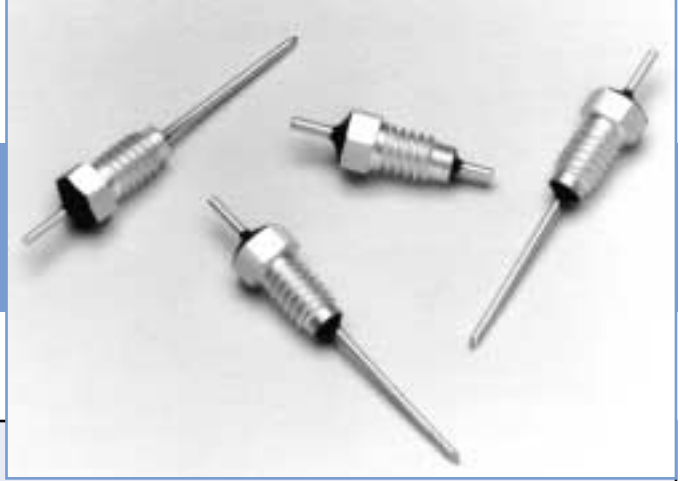

## 4-40 L and Pi Circuit

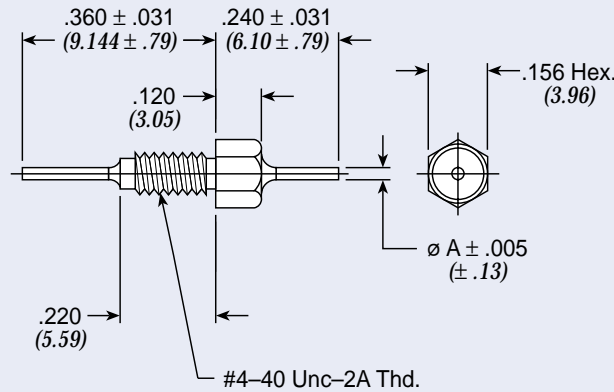

Figure 1

Dimensions in inches (mm)

Part Number	Figure	Rated Voltage 125°C		I Amp	CKT	Min Cap	A		Minimum Insertion Loss (dB)							
		DC	AC				In	(mm)	1 MHz	3 MHz	10 MHz	30 MHz	100 MHz	300 MHz	1 GHz	10 GHz
+51-729-305	1	50	—	3	Pi	5500 pF	0.018	(0.46)	—	7	14	40	60	70	70	70
+51-729-312	1	50	—	3	Pi	7000 pF	0.018	(0.46)	—	8	15	40	65	70	70	70
SCI-3102-002	1	50	—	3	LB	0.075 μF	0.016	(0.41)*	18	25	37	42	52	55	70	70
SCI-3102-000	1	50	—	5	LB	0.075 μF	0.016	(0.41)	18	25	37	42	52	55	70	70
SCI-3102-007	1	50	—	10	LB	0.075 μF	0.025	(0.64)	18	25	37	42	52	55	70	70
+51-729-304	1	100	—	3	LB	0.022 μF	0.018	(0.46)	7	17	27	34	43	47	55	55
+SCI-3112-002	1	100	—	3	LB	0.027 μF	0.016	(0.41)*	10	20	30	38	45	45	65	70
+SCI-3112-000	1	100	—	5	LB	0.027 μF	0.016	(0.41)	10	20	30	38	45	45	65	70
SCI-3112-007	1	100	—	10	LB	0.027 μF	0.025	(0.64)	10	20	30	38	45	45	65	70
SCI-3112-102	1	100	—	3	LB	0.05 μF	0.016	(0.41)*	15	24	35	42	54	56	70	70
SCI-3112-100	1	100	—	5	LB	0.05 μF	0.016	(0.41)	15	24	35	42	54	56	70	70
SCI-3112-107	1	100	—	10	LB	0.05 μF	0.025	(0.64)	15	24	35	42	54	56	70	70
+51-729-303	1	200	—	3	Pi	1500 pF	0.018	(0.46)	—	—	5	15	42	65	70	70
SCI-3122-002	1	200	115	3	LB	0.01 μF	0.016	(0.41)*	—	12	21	30	41	45	70	70
SCI-3122-000	1	200	115	5	LB	0.01 μF	0.016	(0.41)	—	12	21	30	41	45	70	70
SCI-3122-007	1	200	115	10	LB	0.01 μF	0.025	(0.64)	—	12	21	30	41	45	70	70

\* Tinned, steel leads.

+ Also available through Spectrum Control's authorized distributors.

# Resin Sealed Bolt-in Filters

## 6-32 C, L, Pi/6-40 Pi

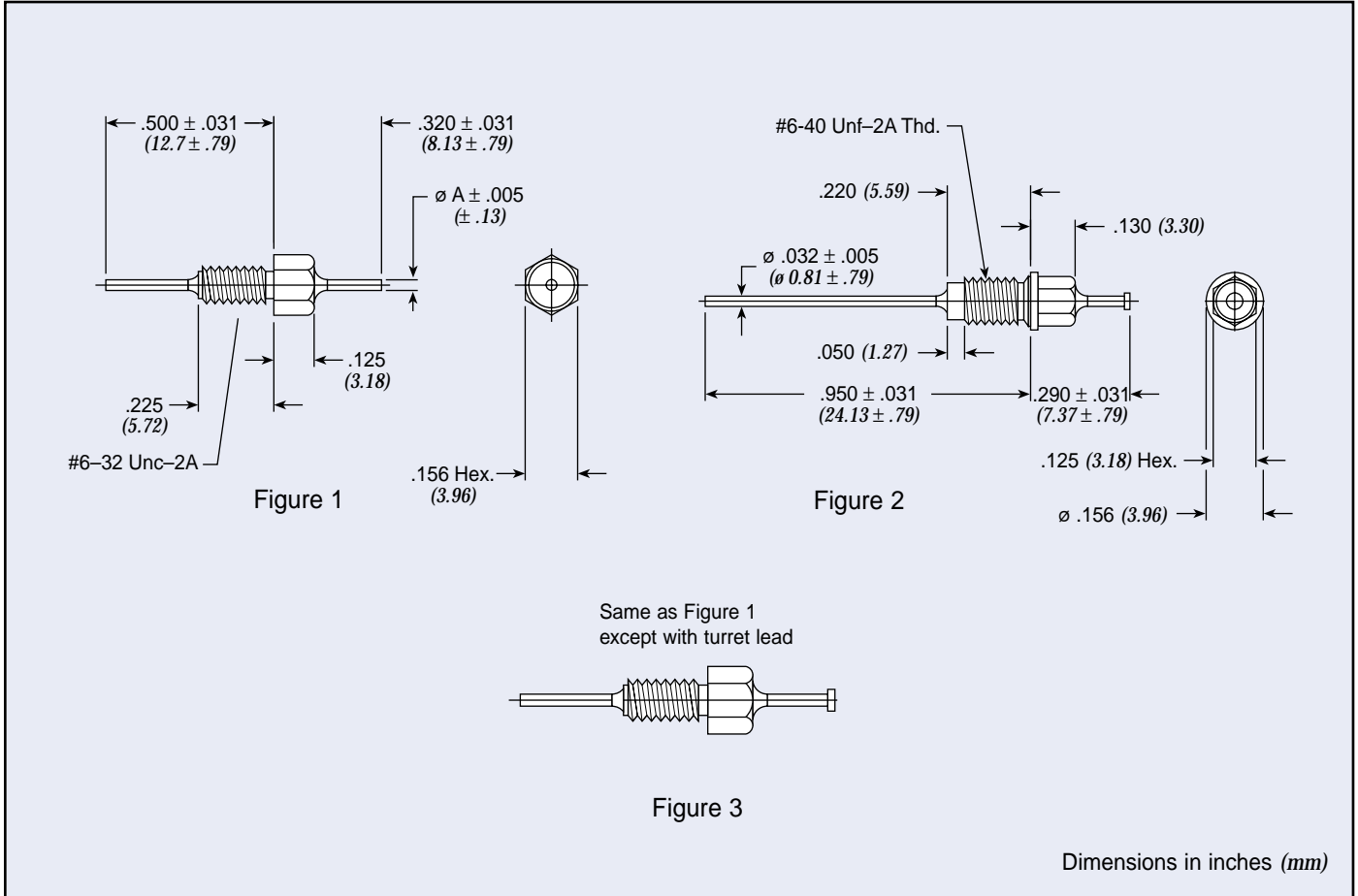

Part Number	Figure	Rated Voltage 125°C		I Amp	CKT	Min Cap	A		Minimum Insertion Loss (dB)							
		DC	AC				In	(mm)	1 MHz	3 MHz	10 MHz	30 MHz	100 MHz	300 MHz	1 GHz	10 GHz
† 51-726-008	1	50	—	3	Pi	5500 pF	0.018	(0.46)	—	7	14	30	55	70	70	70
† 51-726-017	1	50	—	3	Pi	9000 pF	0.018	(0.46)	—	8	18	45	65	70	70	70
54-779-019	1	50	—	10	C	0.10 µF	0.032	(0.81)	22	31	40	44	47	55	65	65
† 54779001X5F100M	1	100	—	10	C	10 pF ± 20%	0.032	(0.81)	—	—	—	—	—	—	10	10
† 54779001X5U102P €	1	100	—	10	C	1000 pF	0.032	(0.81)	—	—	10	21	28	28	28	28
54-779-014	1	100	—	10	C	2700 pF	0.032	(0.81)	—	—	9	18	27	33	35	35
54-779-016	1	100	—	10	C	0.01 µF	0.032	(0.81)	—	9	20	29	38	45	50	50
† 51-726-002	3	100	—	10	LB	0.022 µF	0.032	(0.81)	7	17	27	34	43	50	60	60
54-779-017	1	100	—	10	C	0.027 µF	0.032	(0.81)	10	20	30	37	45	50	55	60
54-779-018	1	100	—	10	C	0.050 µF	0.032	(0.81)	15	24	34	41	45	50	60	60
† 51-726-001	1	200	—	3	Pi	1500 pF	0.018	(0.46)	—	—	5	15	42	65	70	70
† 1289-001	2	200	—	10	Pi	1500 pF	—	—	—	—	5	15	40	60	60	60
† 1289-004	2	200	—	10	Pi	3000 pF	—	—	—	—	8	15	50	65	70	70
54-779-015	1	200	—	10	C	5600 pF	0.032	(0.81)	—	—	15	24	33	37	40	40

† Also available through Spectrum Control's authorized distributors.

€ Also available through Spectrum Control's authorized European distributors/agents.

# Resin Sealed Bolt-in Filters



## 8-32 C Circuit

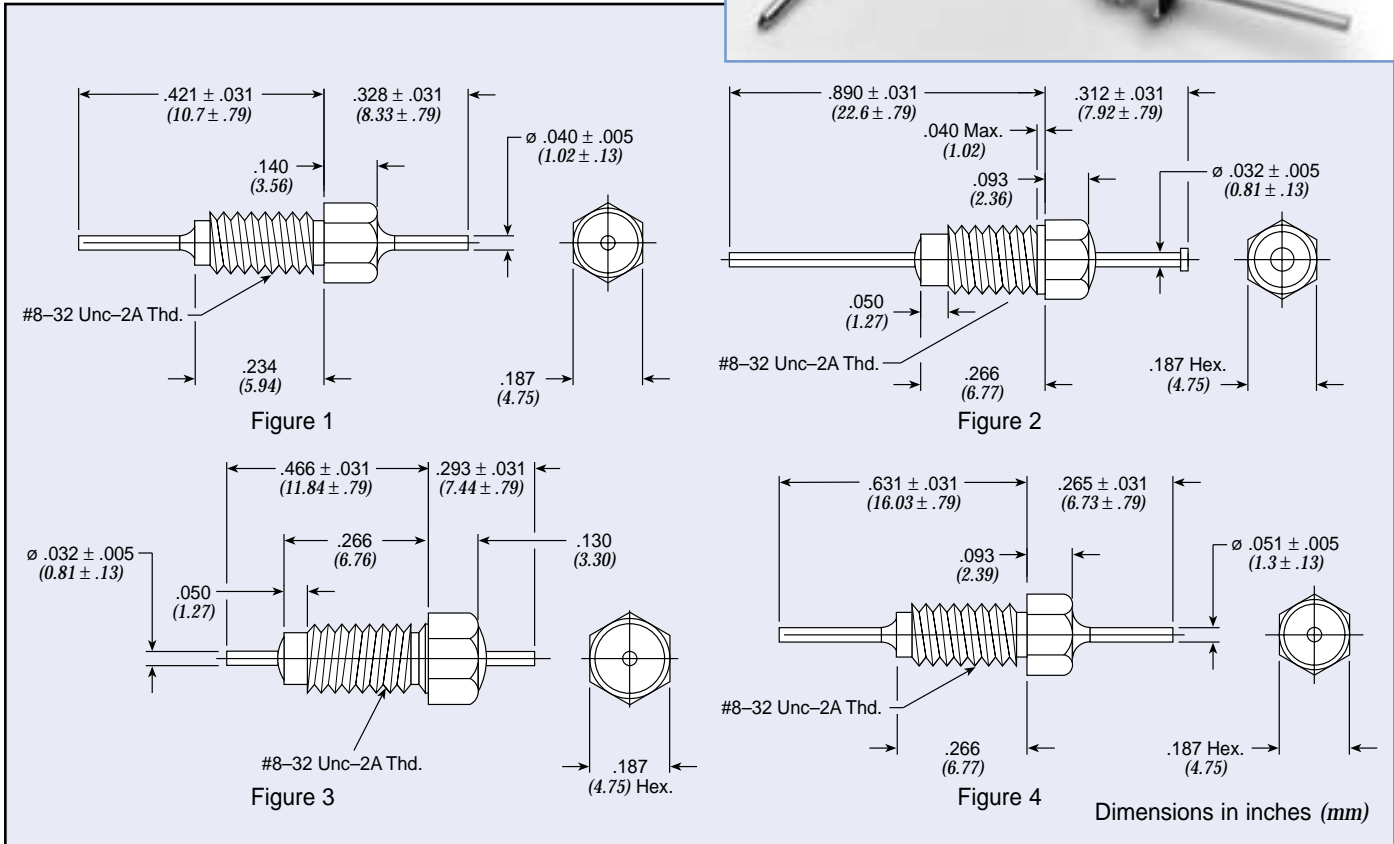

Part Number	Figure	Rated Voltage 125°C		I Amp	Min Cap	Minimum Insertion Loss (dB)							
		DC	AC			1 MHz	3 MHz	10 MHz	30 MHz	100 MHz	300 MHz	1 GHz	10 GHz
SCI-9200-503	2	50	—	10	0.05 μF	15	24	35	41	45	50	60	60
9950-381-6009	3	50	—	10	0.12 μF	20	30	43	45	55	55	55	55
† 54-785-017	1	50	—	10	0.21 μF	28	37	45	50	55	60	70	70
9950-381-6008	3	70	—	10	0.08 μF	15	24	37	41	51	51	55	55
† 54713001X5F101M	4	100	—	10	80 pF	—	—	—	—	—	10	20	20
† 54713001X5U102P	4	100	—	10	1000 pF	—	—	—	11	20	28	28	28
54-785-013	1	100	—	10	0.01 μF	—	9	20	29	38	45	50	55
SCI-9210-103	2	100	—	10	0.01 μF	—	12	20	29	38	45	50	50
SCI-9210-273	2	100	—	10	0.027 μF	10	20	30	36	45	50	55	60
† 54-785-005	1	100	—	10	0.05 μF	15	24	34	41	45	50	60	60
9950-381-6007	3	100	—	10	0.05 μF	13	24	29	37	37	44	44	55
54-785-016	1	100	—	10	0.1 μF	20	29	38	44	47	55	65	65
54-785-011	1	150	—	10	2000 pF	—	—	8	17	26	32	34	35
54-785-012	1	150	—	10	5000 pF	—	6	15	24	33	37	40	40
SCI-9220-101	2	200	115	10	100 pF	—	—	—	—	—	10	20	25
SCI-9220-102	2	200	115	10	1000 pF	—	—	—	11	20	28	28	28
SCI-9220-502	2	200	115	10	5000 pF	—	6	15	24	33	37	40	40

† Also available through Spectrum Control's authorized distributors.

# Resin Sealed Bolt-in Filters

## 8-32 L & Pi Circuit

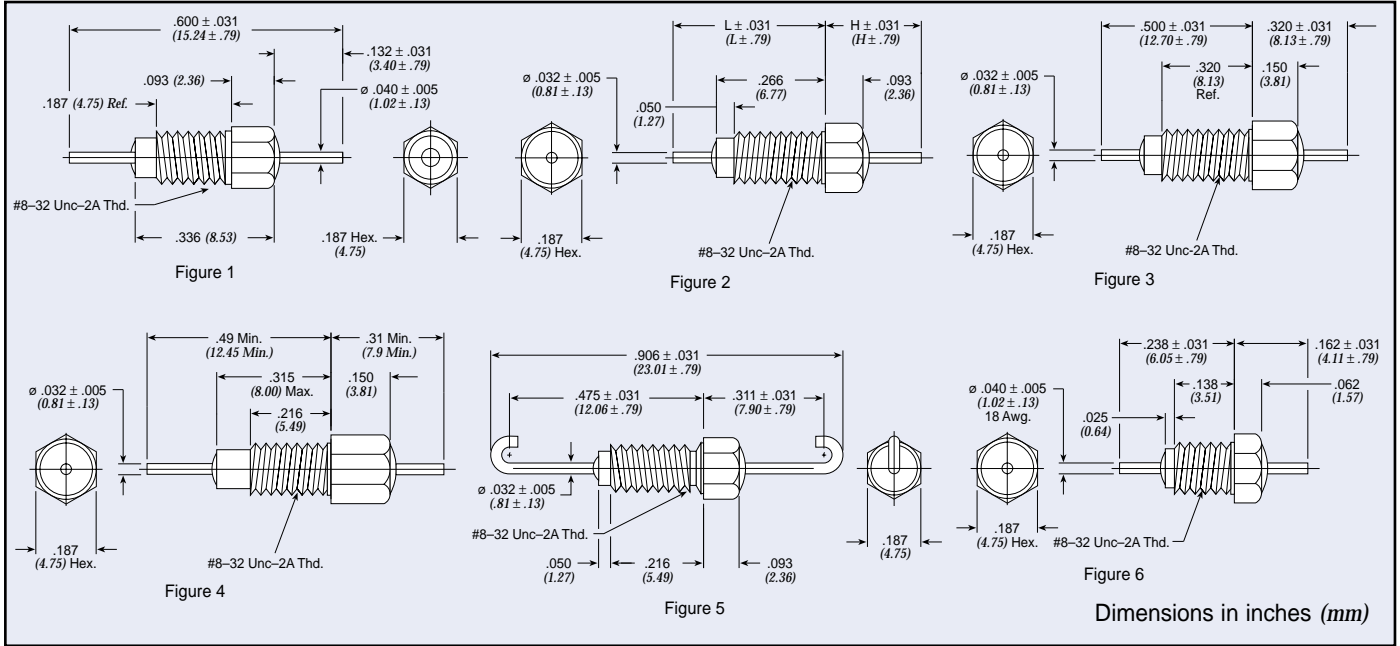

Low Pass Filters

Part Number	M15733 MIL Number	Fig.	Rated Voltage 125°C		I Amp	CKT	Min Cap	H In	H (mm)	L In	L (mm)	Minimum Insertion Loss (dB)							
			DC	AC								1 MHz	3 MHz	10 MHz	30 MHz	100 MHz	300 MHz	1 GHz	10 GHz
51-712-069 €	—	2	50	—	10	Pi	0.012 µF	0.265	(6.73)	0.413	(10.49)	5	9	18	45	65	70	70	70
+ 51-712-065	/61-0014	4	50	—	20	Pi	0.012 µF	0.310	(7.87)	0.490	(12.45)	—	10	20	30	65	70	70	70
+ 1250-054	—	2	70	—	10	Pi	5000 pF	0.312	(7.92)	0.500	(12.70)	—	—	20	30	65	65	70	70
+ 1293-001	—	3	70	—	10	Pi	0.028 µF	—	—	—	—	10	14	38	65	75	75	75	75
51-712-055	/43-0002	2	100	70	10	Pi	3000 pF	0.312	(7.92)	0.578	(14.68)	—	—	5	15	45	50	50	50
+ 51-712-014	/28-0001	2	100	70	10	Pi	3000 pF	0.312	(7.92)	0.890	(22.61)	—	—	5	15	45	60	60	60
51-712-028	/28-0002	5	100	70	10	Pi	3000 pF	—	—	—	—	—	—	5	15	45	60	60	60
+ 51-712-063*	/61-0008	2	100	70	5	Pi	5500 pF	0.312	(7.92)	0.500	(12.70)	—	—	15	35	65	70	70	70
+ 51-712-003 ◊	—	2	100	—	10	LB	0.022 µF	0.280	(7.11)	0.850	(21.59)	7	17	27	34	43	50	60	60
51-712-060 ◊	/28-0004	2	100	70	10	LB	0.022 µF	0.312	(7.92)	0.890	(22.61)	10	17	28	34	41	50	60	60
+ 51-712-067	/61-0013	2	100	—	10	LB	0.031 µF	0.280	(7.11)	0.890	(22.61)	10	20	30	38	42	52	60	60
51-762-006	/44-0003	6	125	85	15	Pi	65 pF	—	—	—	—	—	—	—	—	—	—	16	42
+ 1250-059	—	6	125	—	15	Pi	1500 pF	—	—	—	—	—	—	5	15	35	45	60	60
+ 51-762-005	/44-0002	6	125	85	15	Pi	1500 pF	—	—	—	—	—	—	5	15	25	35	50	50
1250-062	—	1	125	—	15	Pi	3000 pF	—	—	—	—	—	—	5	15	45	45	70	70
+ 51-744-003*	/44-0001	1	125	85	15	Pi	3000 pF	—	—	—	—	—	—	10	15	30	40	65	65
+ SCI-3223-000	—	2	200	115	10	Pi	2000 pF	0.312	(7.92)	0.890	(22.61)	—	—	8	10	48	50	70	70
+ 1250-003 €	—	2	200	—	10	Pi	3000 pF	0.312	(7.92)	0.890	(22.61)	—	—	5	15	45	65	70	70
+ 51-712-001*	—	2	200	—	10	Pi	3000 pF	0.312	(7.92)	0.890	(22.61)	—	—	5	15	45	65	70	70
1250-049	—	2	200	—	10	Pi	3000 pF	0.312	(7.92)	0.578	(14.68)	—	—	5	15	45	65	65	60
+ 51-744-002 ◊	—	2	200	—	10	Pi	5500 pF	0.265	(6.73)	0.413	(10.49)	—	7	14	30	55	70	70	70
+ 1293-000	—	3	200	—	10	Pi	0.012 µF	—	—	—	—	5	10	28	40	65	70	70	70

+ Also available through Spectrum Control's authorized distributors.

◊ Supplied with .040" (1.02mm) diameter lead.

€ Also available through Spectrum Control's authorized European distributors/agents.

\* Denotes parts with turret lead.

# Resin Sealed Bolt-in Filters

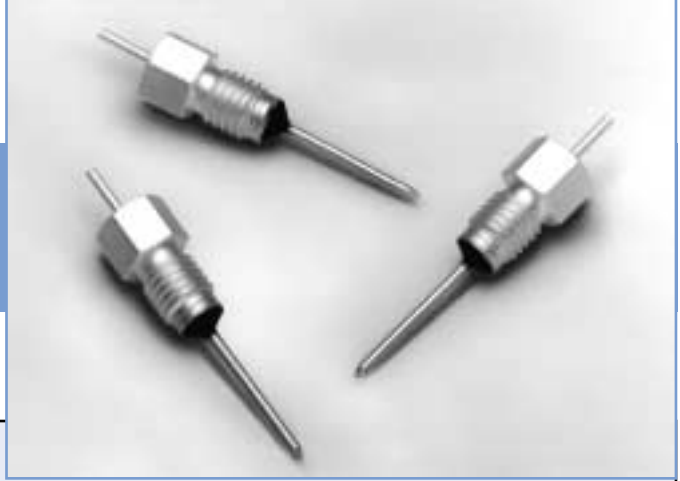

## 10-32 C & Pi Circuit

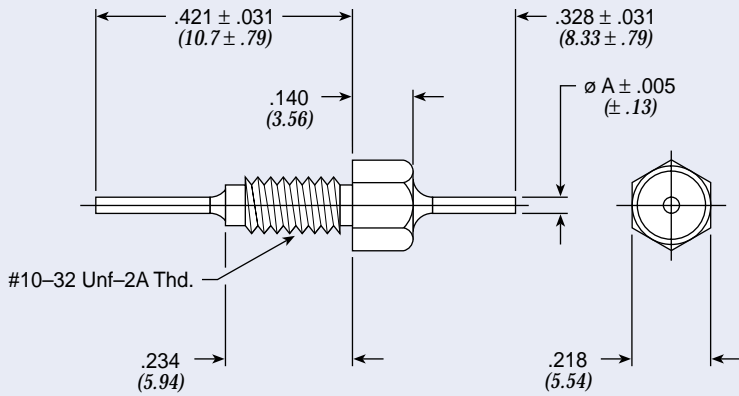

Figure 1

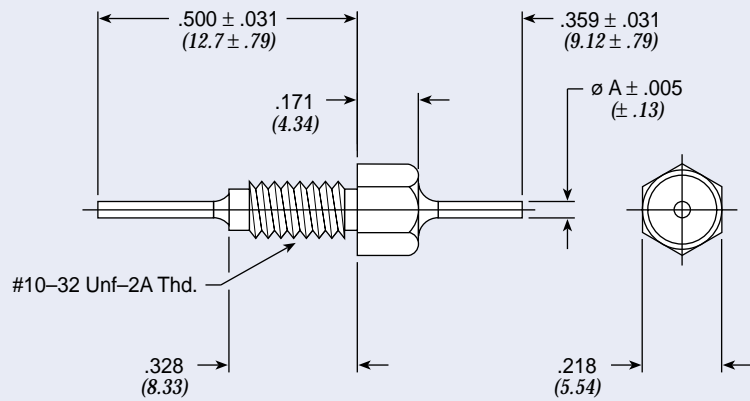

Figure 2

Dimensions in inches (mm)

Part Number	Figure	Rated Voltage 125°C		I Amp	CKT	Min Cap	A		Minimum Insertion Loss (dB)							
		DC	AC				In	(mm)	1 MHz	3 MHz	10 MHz	30 MHz	100 MHz	300 MHz	1 GHz	10 GHz
51-761-002	1	50	—	10	Pi	0.018 μF	0.032	(0.81)	7	14	30	55	70	70	70	70
† 54-786-013	1	50	—	10	C	0.3 μF	0.040	(1.02)	30	38	47	50	55	60	70	70
54-786-028	1	50	—	10	C	0.56 μF	0.040	(1.02)	35	43	50	52	60	65	70	70
† 54-786-014	2	50	—	10	C	0.8 μF	0.040	(1.02)	40	46	52	54	70	70	70	70
51-761-001	1	100	—	10	Pi	0.01 μF	0.032	(0.81)	—	10	20	45	65	70	70	70
54-786-027	1	200	—	10	C	0.1 μF	0.040	(1.02)	20	29	38	44	47	55	65	65

† Also available through Spectrum Control's authorized distributors.

# Resin Sealed Bolt-in Filters

## 12-28 C /12-32 C Circuit

Low Pass Filters

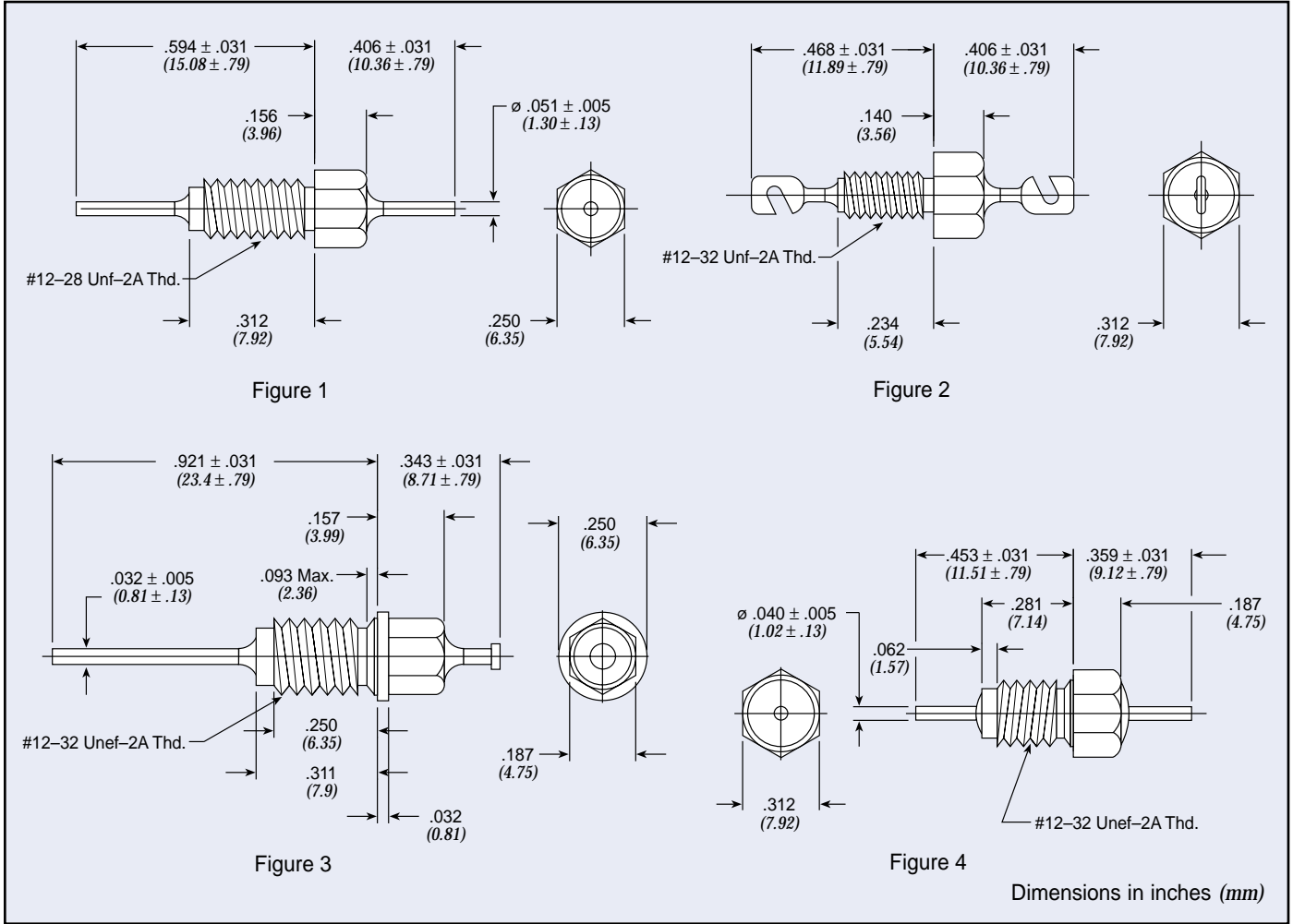

Part Number	Figure	Rated Voltage 125°C		I Amp	CKT	Min Cap	Minimum Insertion Loss (dB)							
		DC	AC				1 MHz	3 MHz	10 MHz	30 MHz	100 MHz	300 MHz	1 GHz	10 GHz
9910-381-6004	4	35	—	15	C	1 μF	38	40	52	52	70	70	78	80
9910-381-6003	4	50	—	15	C	0.75 μF	35	37	51	51	61	61	65	70
SCI-9310-273	3	100	—	10	C	0.027 μF	10	20	30	37	45	50	55	60
9910-381-6002	4	100	—	15	C	0.30 μF	28	30	45	50	55	55	60	65
54804002X5R101M	2	250	—	10	C	100 pF ± 20%	—	—	—	—	—	10	20	25
† 54804002X5R471M	2	250	—	10	C	470 pF ± 20%	—	—	—	—	12	22	25	28
† 54804002X5V102P	2	250	—	10	C	1000 pF	—	—	—	10	21	28	28	28
54743001X5U102Z	1	250	—	15	C	1000 pF	—	—	—	—	20	28	28	28

† Also available through Spectrum Control's authorized distributors.

# Resin Sealed Bolt-in Filters



## 12-28 & 12-32 Pi Circuit

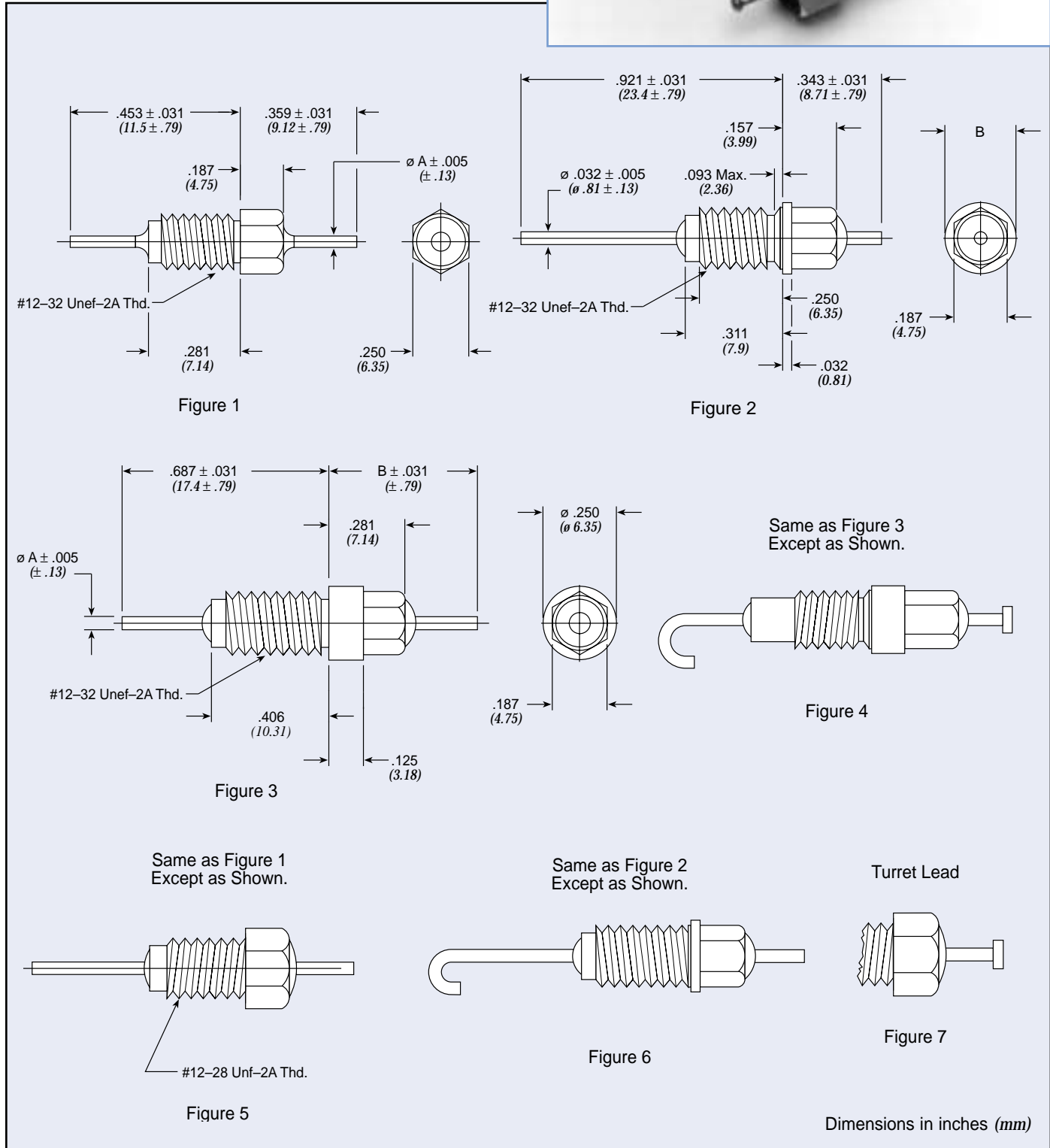

Low Pass Filters

# Resin Sealed Bolt-in Filters

## 12-28 & 12-32 Pi Circuit

Part Number	M15733 MIL Number	See Pg. 79 for Fig.	Rated Voltage 125°C		I Amp	Min Cap	A		B		Minimum Insertion Loss (dB)							
			DC	AC			In	(mm)	In	(mm)	1 MHz	3 MHz	10 MHz	30 MHz	100 MHz	300 MHz	1 GHz	10 GHz
			51-709-013	—			3	50	—	10	0.1 μF	0.040	(1.02)	0.437	(11.10)	10	40	52
SCI-3303-000*	—	2	50	—	10	0.15 μF	0.032	(0.81)	0.250	(6.35)	12	43	68	70	70	70	70	70
51-709-015	/61-0009	3	70	—	10	0.012 μF	0.032	(0.81)	0.470	(11.94)	—	—	—	—	65	65	65	65
† 1216-001	—	3	70	—	10	0.050 μF	0.032	(0.81)	0.468	(11.89)	15	20	60	65	75	75	75	75
† 1270-016*	—	2	100	—	10	5500 pF	0.032	(0.81)	0.250	(6.35)	—	7	20	35	65	70	70	70
† 1270-025	—	2	100	—	10	5500 pF	0.032	(0.81)	0.235	(5.97)	—	7	20	35	65	70	70	70
† 1201-066	—	1	100	—	10	5500 pF	0.032	(0.81)	—	—	—	7	20	40	68	70	70	70
51-714-055*	/61-0011	2	100	—	10	5500 pF	0.032	(0.81)	0.235	(5.97)	—	7	20	—	65	70	70	70
51-714-054*	/61-0010	2	100	—	10	5500 pF	0.032	(0.81)	0.250	(6.35)	—	7	20	—	65	70	70	70
51-714-053*	/61-0007	2	100	70	10	5500 pF	0.032	(0.81)	0.250	(6.35)	—	7	—	—	65	70	70	70
51-714-058*	—	2	100	—	10	0.025 μF	0.040	(1.02)	0.250	(6.35)	10	15	40	60	70	70	70	70
51-714-056	/61-0012	6	100	—	10	0.025 μF	0.032	(0.81)	0.235	(5.97)	—	—	—	—	65	65	65	65
† SCI-3313-000*	—	2	100	—	10	0.10 μF	0.032	(0.81)	0.250	(6.35)	10	40	65	70	70	70	70	70
51-719-022	—	1	200	—	10	1300 pF	0.040	(1.02)	—	—	—	—	5	10	35	60	70	70
† 1201-052	—	5	200	—	10	3000 pF	0.032	(0.81)	—	—	—	—	5	15	45	45	70	70
† 1201-054	—	1	200	—	10	3000 pF	0.032	(0.81)	—	—	—	—	5	15	45	45	70	70
51-714-001*	—	2	200	—	10	3000 pF	0.032	(0.81)	0.250	(6.35)	—	—	5	15	43	60	70	70
† 1270-024	—	2	200	—	10	3000 pF	0.032	(0.81)	0.235	(5.97)	—	—	5	15	45	45	70	70
51-714-003*	—	2	200	—	10	3000 pF	0.032	(0.81)	0.235	(5.97)	—	—	5	15	43	60	70	70
† 1270-009	—	2	200	—	10	3000 pF	0.032	(0.81)	0.250	(6.35)	—	—	5	15	45	45	70	70
51-719-053**	/61-0001	5	200	140	10	3000 pF	0.032	(0.81)	—	—	—	—	—	—	45	—	70	70
51-719-054*	/61-0002	1	200	140	10	3000 pF	0.032	(0.81)	—	—	—	—	—	—	45	45	70	70
51-714-051*	/61-0005	2	200	140	10	3000 pF	0.032	(0.81)	0.250	(6.35)	—	—	—	—	45	45	70	70
51-719-023*	/43-0001	5	200	140	10	3000 pF	0.032	(0.81)	—	—	—	—	—	—	45	45	45	45
51-714-052*	/61-0006	2	200	140	10	3000 pF	0.032	(0.81)	0.235	(5.97)	—	—	—	—	45	45	70	70
51-714-004*	—	2	200	—	10	5500 pF	0.032	(0.81)	0.235	(5.97)	—	7	14	35	60	70	70	70
† 51-719-021	—	1	200	—	10	5500 pF	0.040	(1.02)	—	—	—	7	14	30	50	65	65	65
€ 51-714-002*	—	2	200	—	10	5500 pF	0.032	(0.81)	0.250	(6.35)	—	7	14	35	60	70	70	70
† SCI-3323-000*	—	2	200	115	10	0.012 μF	0.032	(0.81)	0.250	(6.35)	—	—	27	30	70	70	70	70
† 1221-001	—	4	300	—	10	5500 pF	0.032	(0.81)	0.437	(11.10)	—	—	15	30	65	70	70	70
† 51-709-004	/46-0001	4	300	—	10	5500 pF	0.032	(0.81)	0.437	(11.10)	—	—	—	—	65	70	70	70
1201-086	—	1	350	—	10	2500 pF	0.032	(0.81)	—	—	—	—	5	10	50	50	65	65
† 51-719-011 €	—	1	500	—	10	3000 pF	0.040	(1.02)	—	—	—	—	12	20	45	60	60	60

† Also available through Spectrum Control's authorized distributors.

€ Also available through Spectrum Control's authorized European distributors/agents.

\* Denotes parts supplied with lead as shown in Figure 7.

\*\* Bushing housing will have 1 1/2 imperfect threads at hex to thread interface.

# Resin Sealed Bolt-in Filters

## 5/16-24 & 5/16-32 C & Pi Circuit

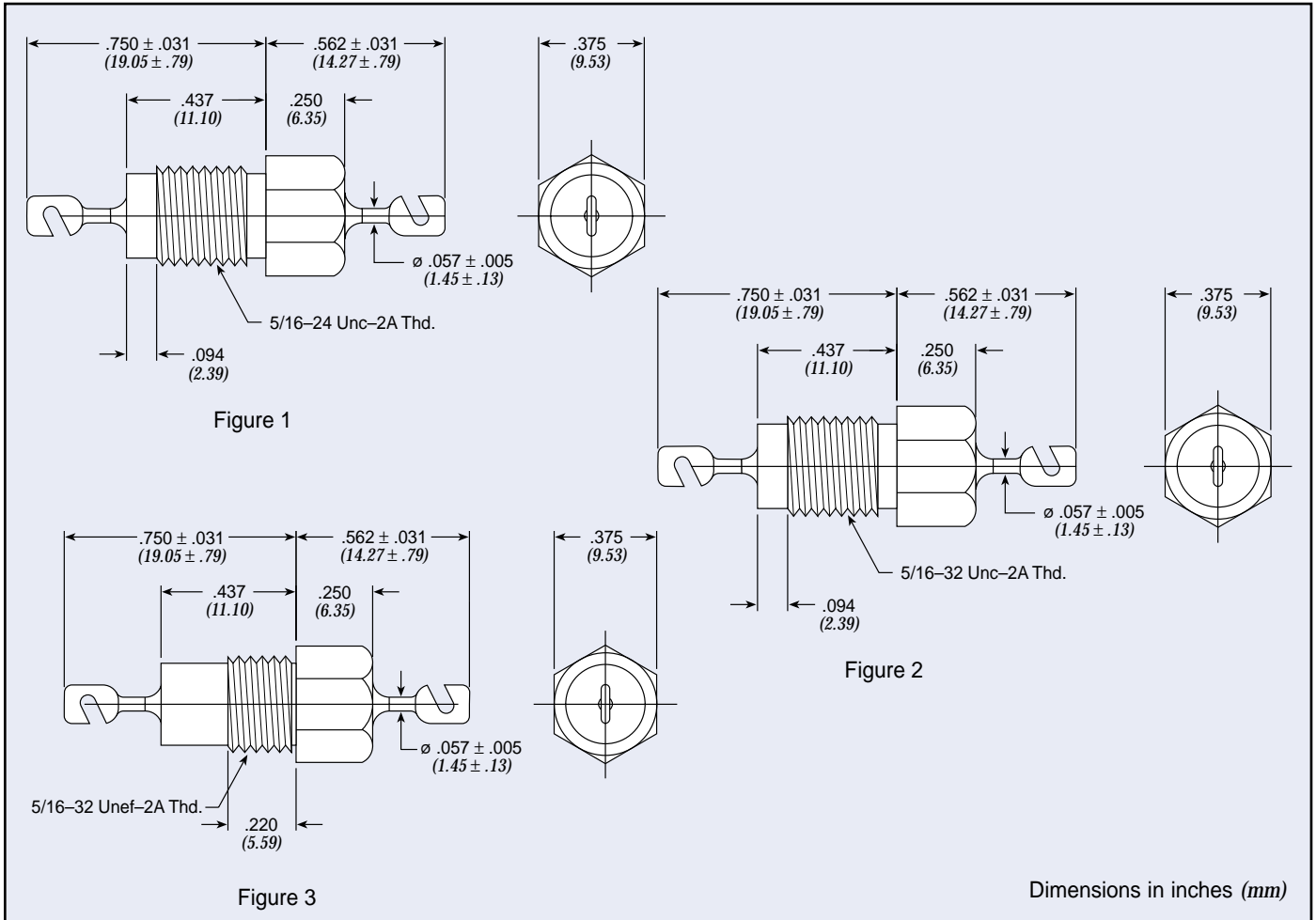

Part Number	M15733 MIL Number	Fig.	Rated Voltage 125°C		I Amp	CKT	Min Cap	Minimum Insertion Loss (dB)							
			DC	AC				1 MHz	3 MHz	10 MHz	30 MHz	100 MHz	300 MHz	1 GHz	10 GHz
SCI-9510-503	—	1	100	—	25	C	0.05 µF	15	24	35	41	45	60	60	60
SCI-3513-000	—	1	100	—	25	Pi	0.1 µF	10	18	28	37	70	70	70	70
SCI-3523-000	—	1	200	115	25	Pi	0.02 µF	—	—	25	50	66	66	70	70
SCI-3543-000	—	1	400	220	25	Pi	6000 pF	—	—	15	35	54	65	70	70
SCI-9550-102	—	1	500	115	25	C	1000 pF	—	—	—	11	20	28	28	28
† 1202-052	—	1	500	—	25	Pi	3000 pF	—	—	10	35	55	55	70	70
† 1202-054	—	2	500	—	25	Pi	3000 pF	—	—	10	35	55	55	70	70
51-702-020*	/61-0003	3	500	350	25	Pi	3000 pF	—	—	—	35	55	55	70	70
51-702-021	/61-0004	3	500	350	25	Pi	3000 pF	—	—	10	35	55	55	70	70
SCI-9550-332	—	1	500	115	25	C	3300 pF	—	—	12	20	30	33	40	40
SCI-3553-000	—	1	500	220	25	Pi	0.012 µF	—	—	18	28	52	52	70	70
† 1202-005	—	2	700	—	25	Pi	2000 pF	—	—	5	20	50	55	70	70

† Also available through Spectrum Control's authorized distributors.

\* Denotes parts with 5/16-24 Threads

# High Current/High Voltage Resin Sealed Filters

High current filters are ideal for use in high current 5 volt logic buss, but also can be used for  $\pm 48$  VDC telephone rack buss, high current switch mode power supplies and DC charging systems. High voltage filters find use in high voltage power supplies and applications requiring U.L. Hi-Pot.

## Features

- Current ratings up to 100 Amps
- Continuous voltage ratings up to 1250 VDC/240 VAC (400Hz)
- U.L. 1459 recognized and CSA C22.2 approved versions available
- Rugged bolt-in style for easy installation



## Installation Notes

for Figure 1 & 2 — see below (Figure 3 see page 16)

1. Mounting installation torque
  - Method A:** Mounting in full threaded thru hole  
**Maximum torque:** 96 in-lbs
  - Method B:** Mounting w/hardware  
**Maximum torque:** 84 in-lbs
2. Terminal installation torque  
**Maximum torque:** 20 in-lbs  
Note: Use two wrench method to install terminal hardware

Low Pass Filters

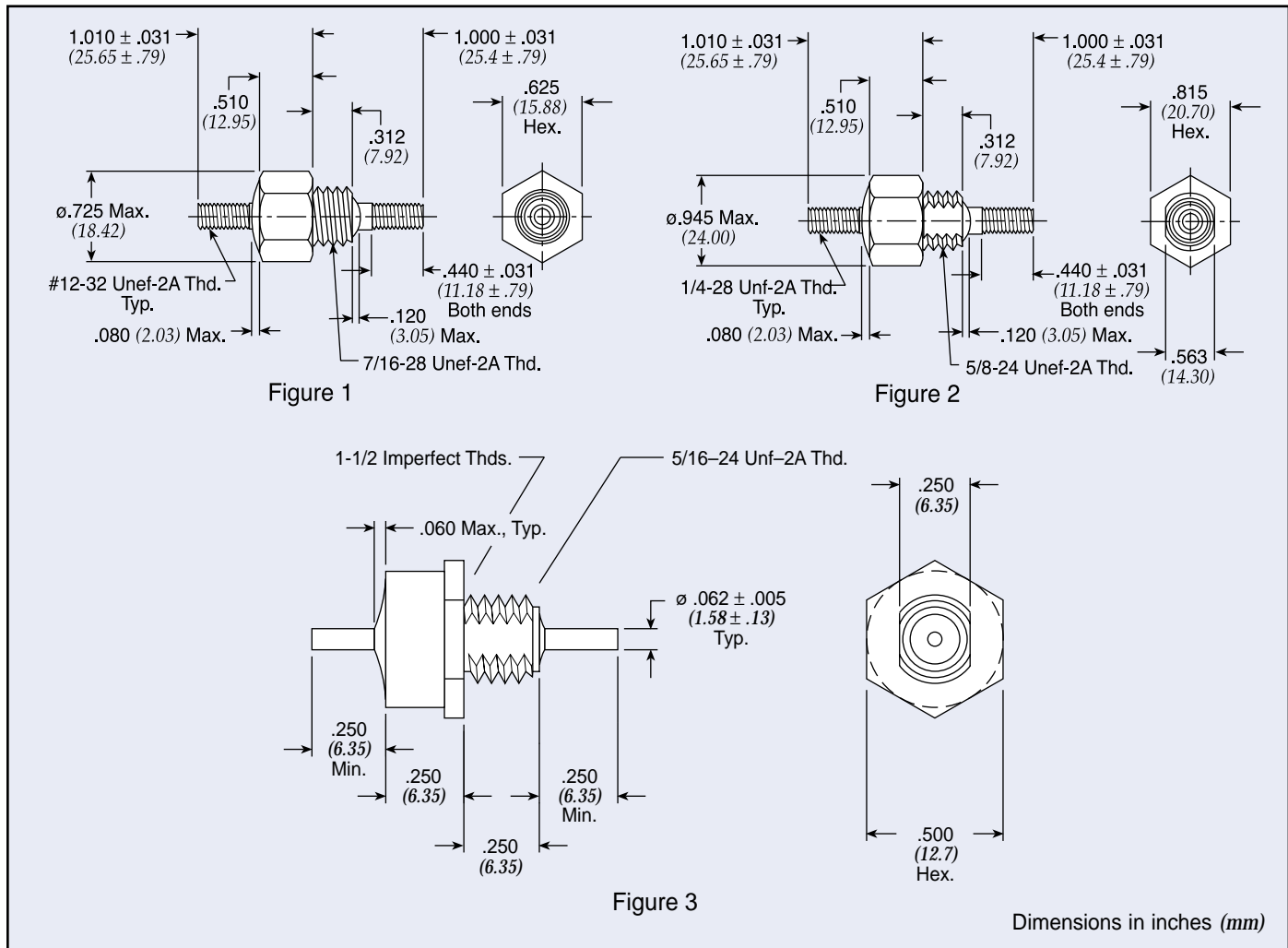

# High Current/High Voltage Resin Sealed Filters

## High Current High Voltage Feed-thru

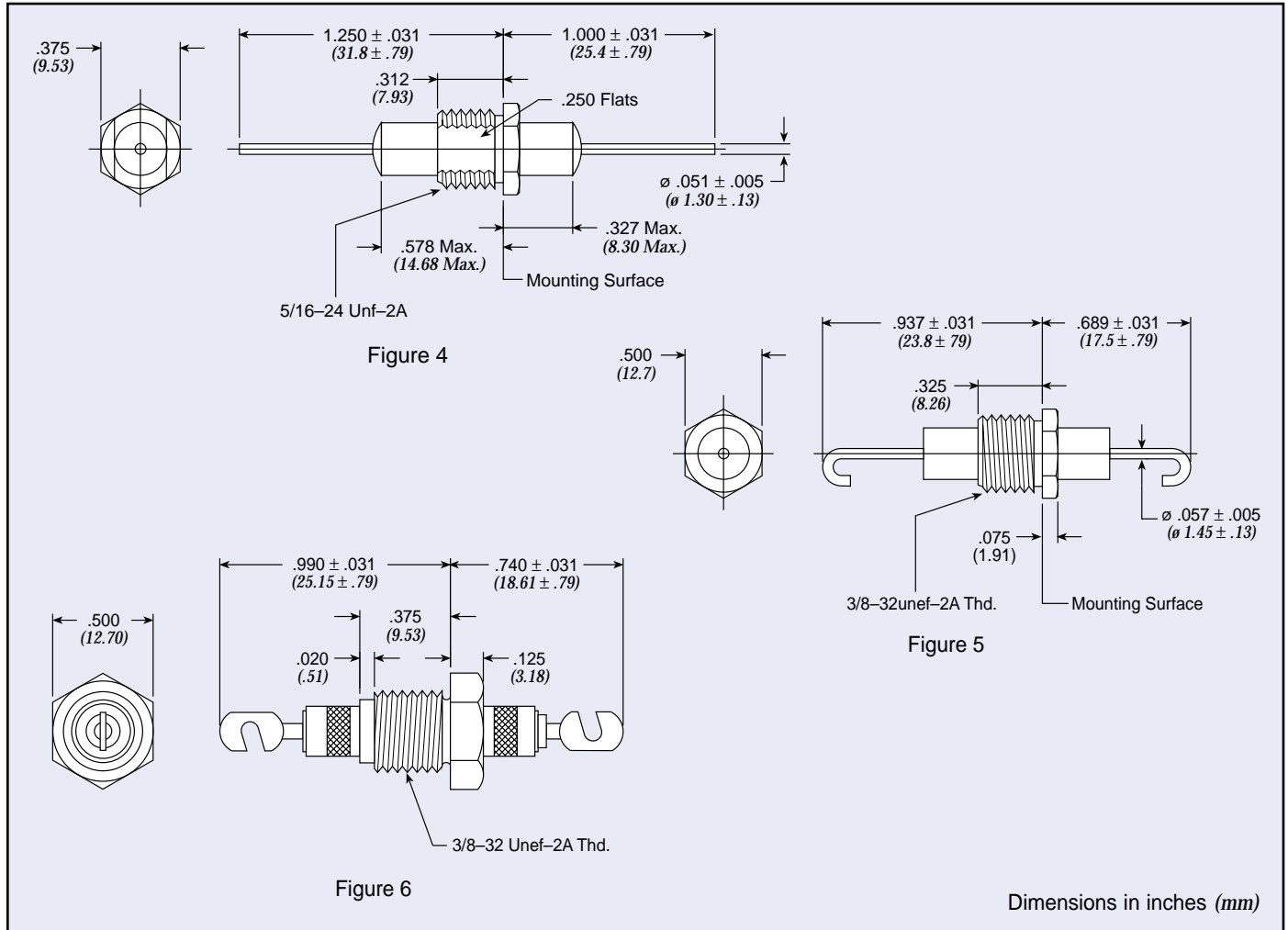

Part Number	Figure	Rated Voltage 125°C		I Amp	CKT	Min Cap	Minimum Insertion Loss (dB)							
		DC	AC***				1 MHz	3 MHz	10 MHz	30 MHz	100 MHz	300 MHz	1 GHz	10 GHz
54-848-005*	1	60	—	50	C	0.22 µF	20	30	40	50	50	50	50	50
54-853-001*	2	60	—	50	C	0.22 µF	20	30	40	50	50	50	50	50
54-853-004 €	2	200	140	100	C	0.22 µF	20	30	40	50	50	50	50	50
54-848-008	1	200	140	100	C	0.22 µF	20	30	40	50	50	50	50	50
54-844-001**	3	600	240	25	C	4700 pF ± 20%	—	—	12	20	30	33	50	50
54-844-002**	3	600	240	25	C	0.01 µF ± 20%	3	7	20	25	35	40	57	57
54-763-008	4	750	—	25	C	1000 pF	—	—	—	10	20	28	28	28
54-763-009	4	750	—	25	C	5000 pF	—	—	10	22	32	35	35	40
54-789-003	5	1250	—	25	C	4000 pF	—	—	6	20	30	35	35	35
† 1280-060 €	6	2500	—	25	Pi	1500 pF	—	—	5	15	50	50	50	50

† Also available through Spectrum Control's authorized distributors.

€ Also available through Spectrum Control's authorized European distributors/agents.

\* Denotes parts that are UL recognized to UL 60950 and certified to CSA C22.2

\*\* Denotes parts that meet 1500 VAC Dielectric Withstanding Voltage per UL 1283 and CSA C22.2

\*\*\* AC Voltage to be 400Hz

# Hermetically Sealed Threaded Case Filters

This series of filters features hermetic glass seals and high EMI filtering performance. They are excellent for critical applications that demand high reliability in the toughest environmental conditions and provide broad-band high performance EMI filtering from 10 KHz to over 10 GHz.

## Features

- Popular .375", .410" and .690" case diameters
- Voltage ratings from 50 VDC to 400 VDC/240 VAC, 400 Hz
- Filter configurations available: C, L, Pi, T and double T
- MIL-F-15733 and MIL-F-28861 QPL filters available



Low Pass Filters

Thread length: A - 0.187 (4.76) B - 0.312 (7.92)

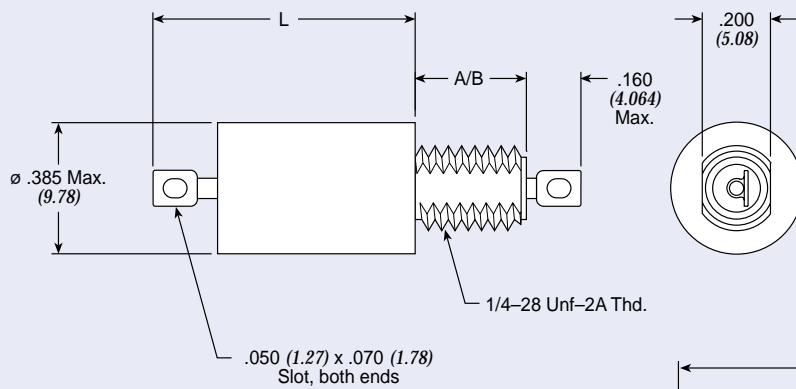

Figure 1

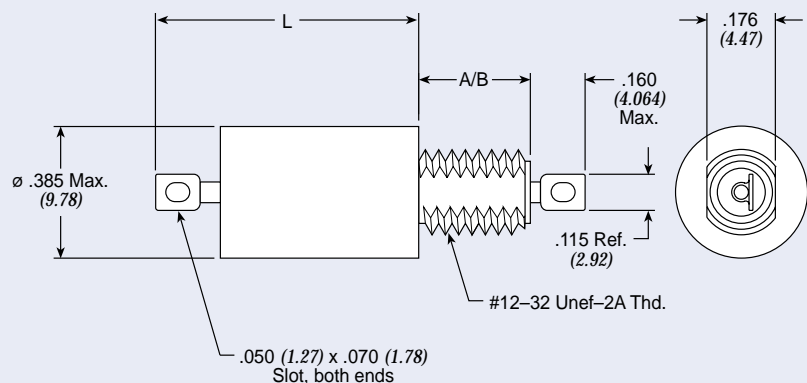

Figure 2

Dimensions in inches (mm)

Note: ø .410 Max. for M28861 parts

# Hermetically Sealed Threaded Case Filters

## .375 ø C Circuit Standard

Part Number	MIL No	See Pg. 84 for Fig.	Rated Voltage				I Amp	Min Cap µF	DCR Max Ohms	Max L		Thd Lgth	Minimum Insertion Loss (dB)						
			85°C		125°C					In	(mm)		30 KHz	150 KHz	300 KHz	1 MHz	10 MHz	100 MHz	1 GHz
			DC	AC	DC	AC													
† 54-367-008	—	1	80	—	50	—	15	1.400	0.005	0.387	(9.830)	A	15	28	33	44	60	70	70
54-370-007	—	1	80	—	50	—	15	2.800	0.005	0.576	(14.630)	A	20	34	39	50	60	70	70
54-371-001	—	1	80	—	50	—	15	4.000	0.005	0.688	(17.475)	A	26	40	46	55	60	70	70
54-367-005	—	1	150	—	100	—	15	0.450	0.005	0.387	(9.830)	A	6	19	25	36	55	70	70
† 9920-100-6002	—	1	200	—	150	125	15	0.150	0.005	0.387	(9.830)	A	—	6	15	26	42	55	70
54-367-007	—	1	250	—	200	125	15	0.015	0.005	0.387	(9.830)	A	—	—	—	6	25	45	50
† 54-367-006	—	1	250	—	200	125	15	0.250	0.005	0.387	(9.830)	A	—	14	19	30	50	65	70
54-370-006	—	1	250	—	200	125	15	0.500	0.005	0.630	(16.002)	A	7	20	28	39	55	70	70
9923-100-6004	—	1	400	—	400	240	15	0.060	0.005	0.415	(10.541)	A	—	5	10	18	38	55	70

## .375 ø C Circuit MIL Qualified (See MIL index on page 237-239 for complete MIL part number listing)

Part Number	M15733 M28861 MIL No	See Pg. 84 for Fig.	Rated Voltage				I Amp	Min Cap µF	DCR Max Ohms	Max L		Thd Lgth	Minimum Insertion Loss (dB)						
			85°C		125°C					In	(mm)		30 KHz	150 KHz	300 KHz	1 MHz	10 MHz	100 MHz	1 GHz
			DC	AC	DC	AC													
54-367-054	1-012◇	1	—	—	50	—	15	1.200	0.008	0.410	(10.414)	B	15	28	33	40	40	70	70
54-367-049	1-002◇	1	—	—	50	—	15	1.200	0.008	0.410	(10.414)	A	15	28	33	40	40	70	70
54-370-032	49-0008	1	—	—	50	—	15	2.100	0.010	0.576	(14.630)	A	20	33	40	50	65	70	70
54-367-055	1-014◇	1	—	—	70	—	15	0.700	0.008	0.410	(10.414)	B	10	24	30	40	40	64	70
54-370-030	34-0035	2	—	—	100	—	10	0.300	0.004	0.474	(12.040)	A	7	19	25	35	55	70	70
54-367-051	1-006◇	1	—	—	100	—	15	0.450	0.008	0.410	(10.414)	A	6	19	25	36	40	60	70
54-367-056	1-016◇	1	—	—	100	—	15	0.450	0.008	0.410	(10.414)	B	6	19	25	36	40	60	70
54-367-057	1-018◇	1	—	—	150	—	15	0.250	0.008	0.410	(10.414)	B	—	14	20	31	40	56	70
54-367-053	1-010◇	1	—	—	200	125	15	0.150	0.008	0.410	(10.414)	A	—	10	16	26	40	52	70
54-367-058	1-020◇	1	—	—	200	125	15	0.150	0.008	0.410	(10.414)	B	—	10	16	26	40	52	70
54-370-034	49-0010	1	—	—	330	—	15	0.062	0.004	0.680	(17.272)	A	—	2	7	17	37	55	70

† Also available through Spectrum Control's authorized distributors.

# Hermetically Sealed Threaded Case Filters

## .375 ø L Circuit

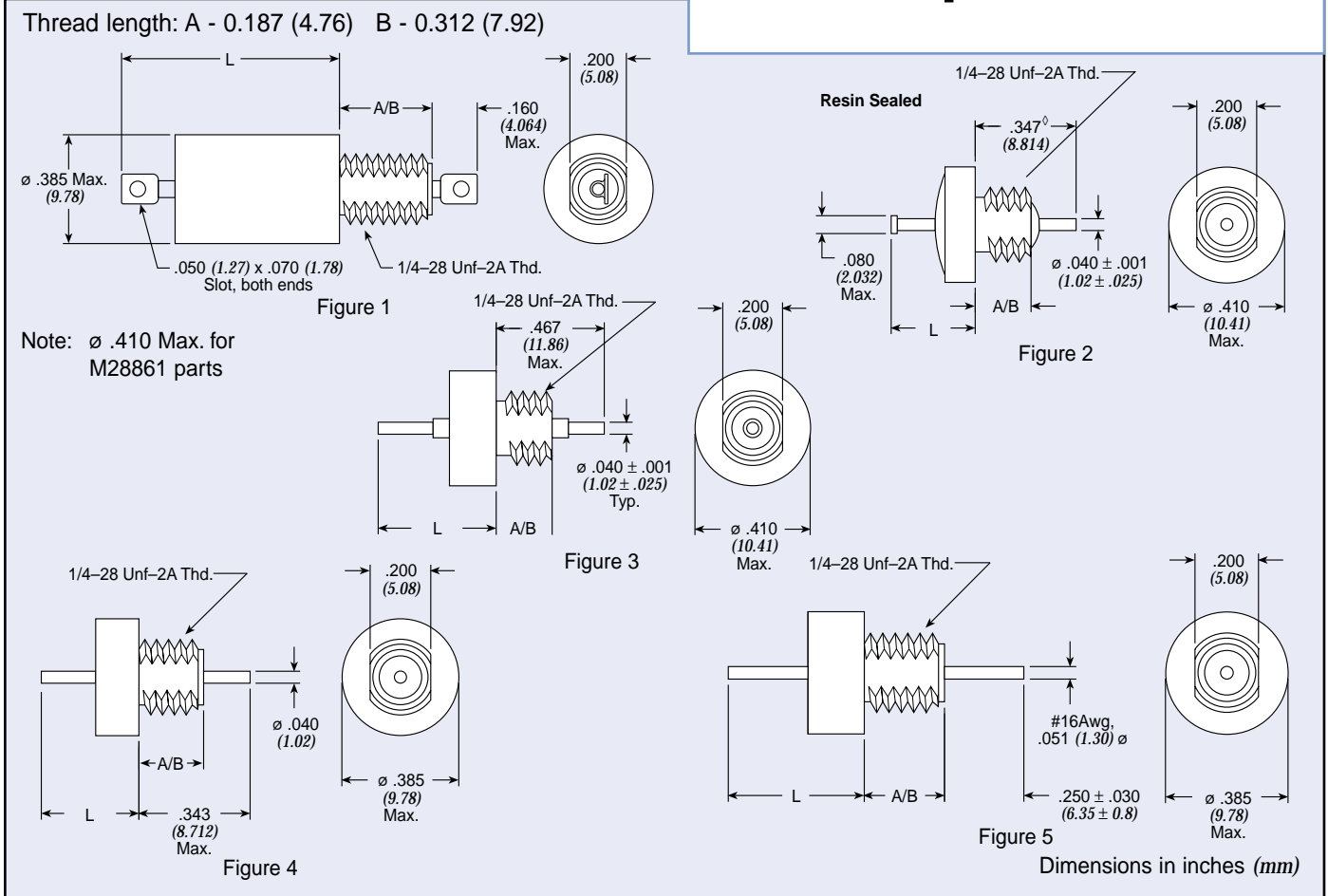

## L-C Filter LT

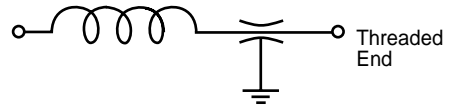

## L-C Filter LB

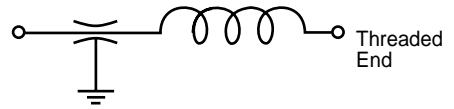

## .375 ø L Standard Low Profile

Part Number	MIL No	Figure	Rated Voltage				I Amp	Min Cap µF	DCR Max Ohms	CKT	Max L		Thd Lgth	Minimum Insertion Loss (dB)						
			85°C		125°C						In	(mm)		30 KHz	150 KHz	300 KHz	1 MHz	10 MHz	100 MHz	1 GHz
			DC	AC	DC	AC														
† 9051-100-0000	—	1	80	—	50	—	15	1.200	0.005	LB	0.370	(9.398)	A	15	25	34	44	60	70	70
† 51-359-001 €	—	1	80	—	50	—	15	1.400	0.010	LB	0.370	(9.398)	A	15	28	33	44	60	70	70
SCI-1021-000	—	2	80	—	50	—	15	1.400	0.003	LB	0.280	(7.112)	A	15	28	33	44	60	70	70
† 9053-100-0001	—	1	80	—	50	—	15	1.400	0.005	LB	0.370	(9.398)	A	15	25	34	44	60	70	70
† 51-717-001 €	—	2	80	—	50	—	15	1.400	0.010	LB	0.325	(8.255)	A	15	28	33	44	60	70	70
51-344-006	—	4	80	—	50	—	15	1.400	0.010	LB	0.330	(8.382)	A	15	28	33	44	60	70	70
† SCI-1020-000	—	1	80	—	50	—	15	1.400	0.003	LB	0.370	(9.398)	A	15	28	33	44	60	70	70
SCI-1021-020	—	2 <sup>o</sup>	80	—	50	—	15	1.400	0.003	LB	0.280	(7.112)	B	15	28	33	44	60	70	70
† SCI-1020-020	—	1	80	—	50	—	15	1.400	0.003	LB	0.370	(9.398)	B	15	28	33	44	60	70	70
SCI-1150-001	—	1	80	—	50	—	15	2.800	0.003	LB	0.450	(11.430)	B	20	34	40	49	60	70	70
9051-101-0018	—	5	80	—	50	—	25	1.400	0.001	LB	0.450	(11.430)	A	15	25	34	44	60	70	70
† 9053-100-0008	—	1	100	—	70	—	15	0.700	0.005	LB	0.370	(9.398)	A	9	20	29	39	52	70	70

† Also available through Spectrum Control's authorized distributors.

€ Also available through Spectrum Control's authorized European distributors/agents.

◊ Note: 0.462" (11.73mm) length from mounting surface to end of lead — not 0.347" (8.8mm).

# Hermetically Sealed Threaded Case Filters

## L-C Filter LT

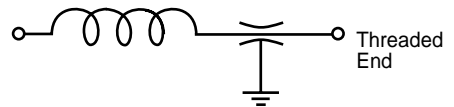

## L-C Filter LB

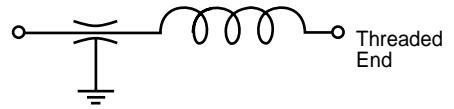

### .375 ø L Standard Low Profile *continued*

Part Number	MIL No	See Pg. 86 for Fig	Rated Voltage				I Amp	Min Cap µF	DCR Max Ohms	CKT	Max L		Thd Lgth	Minimum Insertion Loss (dB)						
			85°C		125°C						In	(mm)		30 KHz	150 KHz	300 KHz	1 MHz	10 MHz	100 MHz	1 GHz
			DC	AC	DC	AC														
+ 9050-100-0008	—	2	100	—	70	—	15	0.750	0.005	LB	0.325	(8.255)	A	9	20	29	39	52	70	70
+ 9053-100-0002	—	1	150	—	100	—	15	0.500	0.005	LB	0.370	(9.398)	A	4	12	21	31	48	70	70
SCI-1250-001	—	1	150	—	100	—	15	0.500	0.003	LB	0.450	(11.430)	B	8	20	25	34	50	64	70
€ SCI-2150-000	—	1	150	—	100	—	15	1.000	0.003	LB	0.450	(11.430)	A	10	25	30	41	56	70	70
SCI-2150-001	—	1	150	—	100	—	15	1.000	0.003	LB	0.450	(11.430)	B	10	25	30	41	56	70	70
+ 51-717-007	—	2	250	125	200	125	15	0.015	0.010	LB	0.325	(8.255)	A	—	—	—	6	25	38	45
+ 51-359-007	—	1	250	125	200	125	15	0.015	0.010	LB	0.370	(9.398)	A	—	—	—	6	25	38	50
9050-100-0011	—	2	250	125	200	125	15	0.150	0.008	LB	0.325	(8.255)	A	—	10	15	25	40	52	60
€ SCI-2350-000	—	1	300	125	300	125	15	0.250	0.003	LB	0.450	(11.430)	A	4	15	21	31	50	70	70
SCI-2350-001	—	1	300	125	300	125	15	0.250	0.003	LB	0.450	(11.430)	B	4	15	21	31	50	70	70

### .375 ø L Circuit MIL Qualified Low Profile

(See MIL index on page 237-239 for complete MIL part number listing)

Part Number	M15733 M28861 MIL No	See Pg. 86 for Fig	Rated Voltage				I Amp	Min Cap µF	DCR Max Ohms	CKT	Max L		Thd Lgth	Minimum Insertion Loss (dB)						
			85°C		125°C						In	(mm)		30 KHz	150 KHz	300 KHz	1 MHz	10 MHz	100 MHz	1 GHz
			DC	AC	DC	AC														
+ 51-359-021	38-0004	1	—	—	50	—	10	1.400	0.008	LB	0.370	(9.398)	A	15	28	33	44	60	70	70
+ 51-359-024	38-0005	1	80	—	50	—	10	1.400	0.008	LB	0.370	(9.398)	A	15	28	33	44	60	70	70
+ 51-359-051	58-0001	1	80	—	50	—	10	1.400	0.008	LB	0.545	(13.843)	A	15	28	33	44	60	70	70
51-359-105	58-0004	1	80	—	50	—	10	1.400	0.008	LT	0.545	(13.843)	B	15	28	33	44	60	70	70
+ 51-359-044	49-0006	1	100	—	50	—	15	1.200	0.010	LB	0.370	(9.398)	A	15	28	33	44	60	70	70
+ 51-359-055	49-0007	3	100	—	50	—	15	1.200	0.010	LB	0.450	(11.43)	A	15	28	33	44	60	70	70
51-359-081	1-001◇	1	—	—	50	—	15	1.400	0.008	LB	0.410	(10.414)	A	15	28	33	40	40	70	70
51-359-086	1-011◇	1	—	—	50	—	15	1.400	0.008	LB	0.410	(10.414)	B	15	28	33	40	40	70	70
+ 51-359-053	49-0001	4	100	—	50	—	15	0.680	0.010	LB	0.319	(8.103)	A	8	20	28	38	55	70	70
51-359-082	1-003◇	1	—	—	70	—	15	0.700	0.008	LB	0.410	(10.414)	A	10	24	30	40	40	64	70
51-359-083	1-005◇	1	—	—	100	—	15	0.450	0.008	LB	0.410	(10.414)	A	6	19	25	36	40	60	70
51-359-088	1-015◇	1	—	—	100	—	15	0.450	0.008	LB	0.410	(10.414)	B	6	19	25	36	40	60	70
51-359-084	1-007◇	1	—	—	150	—	15	0.250	0.008	LB	0.410	(10.414)	A	—	14	20	31	40	56	70
51-359-050	38-0008	1	—	—	200	125	15	0.030	0.008	LB	0.370	(9.398)	A	—	—	—	6	25	42	60
51-359-085	1-009◇	1	—	—	200	125	15	0.150	0.008	LB	0.410	(10.414)	A	—	10	16	26	40	52	70
51-359-090	1-019◇	1	—	—	200	125	15	0.150	0.008	LB	0.410	(10.414)	B	—	10	16	26	40	52	70

† Also available through Spectrum Control's authorized distributors.

€ Also available through Spectrum Control's authorized European distributors/agents.

# Hermetically Sealed Threaded Case Filters

## .375 ø L Circuit

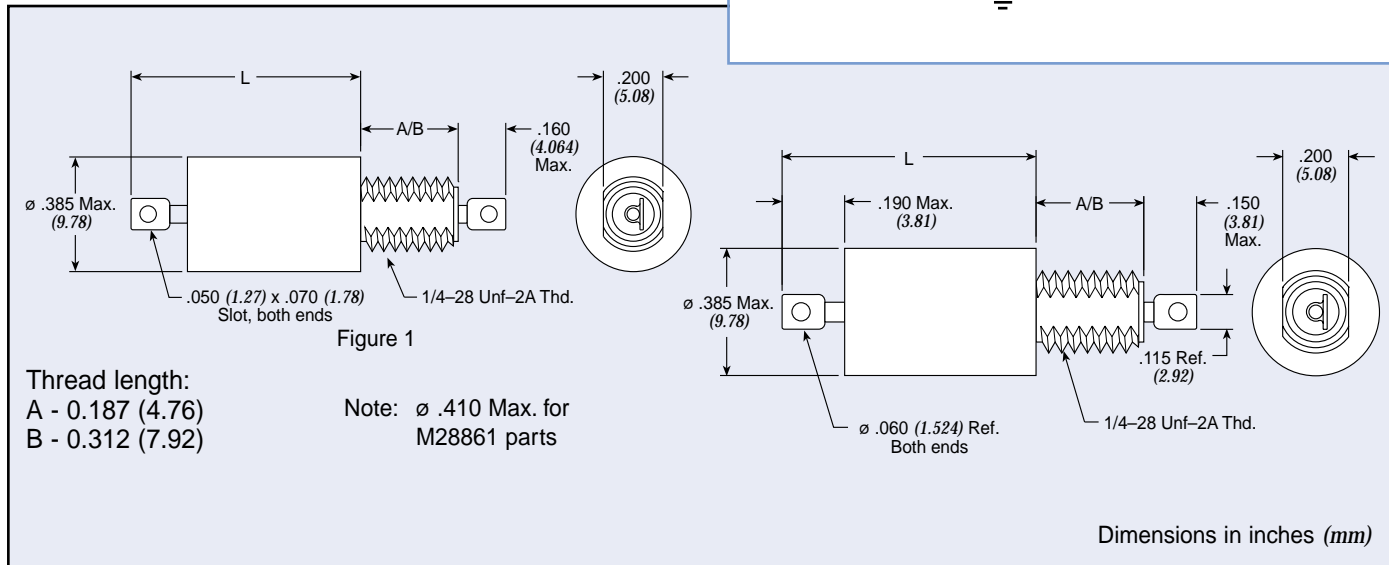

## .375 ø L Circuit Standard Product

Part Number	MIL No	Figure	Rated Voltage				I Amp	Min Cap µF	DCR Max Ohms	CKT	Max L In	Max L (mm)	Thd Lgth	Minimum Insertion Loss (dB)						
			85°C DC	85°C AC	125°C DC	125°C AC								30 KHz	150 KHz	300 KHz	1 MHz	10 MHz	100 MHz	1 GHz
51-353-007	—	1	80	—	50	—	0.06	1.400	70.000	LB	0.770	(19.558)	A	44	70	70	70	70	70	70
51-353-095	—	1	80	—	50	—	0.15	1.400	12.000	LT	0.960	(24.384)	A	21	52	64	70	70	70	70
51-353-003	—	1	80	—	50	—	0.45	1.400	1.200	LB	0.770	(19.558)	A	16	31	37	55	70	70	70
51-353-099	—	1	80	—	50	—	1.00	1.400	0.250	LT	0.770	(19.558)	A	16	33	44	70	70	70	70
51-353-100	—	1	80	—	50	—	5.00	1.400	0.015	LT	0.770	(19.558)	A	15	28	33	46	70	70	70
† 9200-300-0025	—	1	80	—	50	—	10.00	1.200	0.010	LB	0.450	(11.430)	A	15	28	33	44	60	70	70

† Also available through Spectrum Control's authorized distributors.

# Hermetically Sealed Threaded Case Filters

## L-C Filter LT

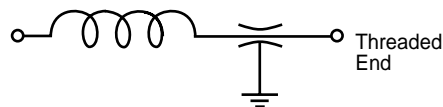

## L-C Filter LB

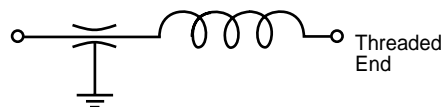

### .375 ø L Circuit Standard Product *continued*

Part Number	MIL No	See Pg. 88 for Fig	Rated Voltage				I Amp	Min Cap µF	DCR Max Ohms	CKT	Max L		Thd Lgth	Minimum Insertion Loss (dB)						
			85°C		125°C						In	(mm)		30 KHz	150 KHz	300 KHz	1 MHz	10 MHz	100 MHz	1 GHz
			DC	AC	DC	AC														
† 9200-303-0095	—	1	80	—	50	—	10.00	1.200	0.010	LB	0.450	(11.430)	B	15	28	33	44	60	70	70
51-353-101	—	1	80	—	50	—	10.00	1.400	0.010	LT	0.450	(11.430)	A	14	28	33	44	60	70	70
51-353-109	—	1	80	—	50	—	10.00	1.400	0.010	LT	0.450	(11.430)	B	15	28	33	44	60	70	70
51-353-120	—	1	150	—	100	—	1.00	0.750	0.250	LB	0.758	(19.253)	A	9	27	36	57	70	70	70
9000-103-0019	—	1	150	—	100	—	5.00	0.450	0.015	LT	0.758	(19.253)	B	6	20	26	37	68	70	70
SCI-2120-014	—	1	150	—	100	—	10.00	1.000	0.003	LB	0.450	(11.430)	B	14	28	34	44	52	70	70
† 51-353-110	—	1	250	—	200	125	1.00	0.250	0.250	LT	0.758	(19.253)	A	—	17	29	50	70	70	70
† 51-353-111	—	1	250	—	200	125	1.00	0.250	0.250	LB	0.758	(19.253)	A	—	17	29	50	70	70	70
51-353-112	—	1	250	—	200	125	3.00	0.250	0.050	LT	0.758	(19.253)	A	—	13	20	35	70	70	70
† 51-353-113	—	1	250	—	200	125	3.00	0.250	0.050	LB	0.758	(19.253)	A	—	13	20	35	70	70	70
51-353-114	—	1	250	—	200	125	5.00	0.250	0.015	LT	0.758	(19.253)	A	—	12	20	30	62	70	70
51-353-116	—	1	250	—	200	125	10.00	0.250	0.010	LT	0.450	(11.430)	A	—	15	20	30	50	70	70
SCI-2320-010	—	1	300	—	300	125	0.50	0.150	1.000	LB	0.758	(19.253)	B	—	23	35	56	70	70	70
SCI-2320-004	—	1	300	—	300	125	1.00	0.150	0.250	LB	0.758	(19.253)	A	—	10	21	41	70	70	70
SCI-2320-005	—	1	300	—	300	125	2.00	0.150	0.063	LB	0.758	(19.253)	A	—	8	14	30	70	70	70
SCI-2320-006	—	1	300	—	300	125	3.00	0.150	0.027	LB	0.758	(19.253)	A	—	8	14	26	64	70	70
SCI-2320-007	—	1	300	—	300	125	10.00	0.150	0.003	LB	0.450	(11.430)	A	—	8	14	25	45	52	70
SCI-2320-014	—	1	300	—	300	125	10.00	0.150	0.003	LB	0.450	(11.430)	B	—	8	14	25	45	52	70

### .375 ø L Circuit MIL Qualified Profile

(See MIL index on pages 237-239 for complete MIL part number listing)

Part Number	M15733 MIL No	See Pg. 88 for Fig	Rated Voltage				I Amp	Min Cap µF	DCR Max Ohms	CKT	Max L		Thd Lgth	Minimum Insertion Loss (dB)						
			85°C		125°C						In	(mm)		30 KHz	150 KHz	300 KHz	1 MHz	10 MHz	100 MHz	1 GHz
			DC	AC	DC	AC														
51-390-018	23-0026	1	—	—	50	—	0.50	1.400	0.360	LB	0.630	(16.002)	A	12	36	48	69	70	70	70
51-390-026	23-0038	1	—	—	50	—	1.00	1.400	0.140	LB	0.630	(16.002)	A	11	26	36	55	70	70	70
51-390-034	23-0050	1	—	—	50	—	2.00	1.400	0.070	LB	0.630	(16.002)	A	10	24	32	48	70	70	70
† 51-353-067	24-0006	1	80	—	50	—	10.00	1.400	0.010	LB	0.760	(19.304)	B	15	28	31	42	56	70	70
51-353-207	34-0007	1	—	—	50	—	10.00	1.400	0.010	LB	0.760	(19.304)	A	15	28	31	42	56	70	70
51-444-072	58-0002	1	80	—	50	—	10.00	1.400	0.008	LT	0.545	(13.843)	A	15	28	33	44	60	70	70
† 51-353-066	24-0005	1	80	—	50	—	10.00	1.400	0.010	LB	0.760	(19.304)	A	15	28	31	42	56	70	70
51-353-287	39-0014	1	—	—	50	—	10.00	1.400	0.003	LT	0.760	(19.304)	B	14	28	34	44	52	70	70
† 51-444-060	24-0008	1	80	—	50	—	10.00	1.400	0.010	LT	0.740	(18.796)	B	15	28	31	42	56	70	70
† 51-343-028	38-0002	1	—	—	50	—	15.00	1.400	0.008	LB	0.481	(12.217)	A	15	28	33	44	64	70	70
† 51-343-034	38-0006	1	—	—	50	—	15.00	1.400	0.008	LB	0.481	(12.217)	B	15	28	33	44	64	70	70
51-353-053	25-0003	1	—	—	100	—	1.00	0.450	0.250	LB	0.738	(18.745)	A	6	23	34	55	70	70	70
† 51-353-054	25-0005	1	—	—	100	—	5.00	0.450	0.015	LT	0.758	(19.253)	A	6	17	23	35	69	70	70
† 51-353-055	25-0008	1	—	—	100	—	5.00	0.450	0.015	LB	0.738	(18.745)	A	6	17	23	35	69	70	70
51-353-155	39-0008	1	—	—	100	—	5.00	0.450	0.015	LB	0.760	(19.304)	A	6	20	26	35	60	60	70
51-444-039	25-0017	1	—	—	100	—	5.00	0.450	0.015	LT	0.758	(19.253)	B	6	17	23	35	69	70	70

† Also available through Spectrum Control's authorized distributors.

# Hermetically Sealed Threaded Case Filters

## L-C Filter LT

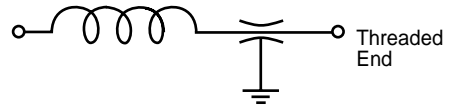

## L-C Filter LB

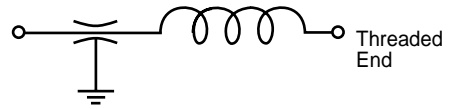

### .375 ø L Circuit MIL Qualified Profile *continued*

(See MIL index on pages 237-239 for complete MIL part number listing)

Part Number	M15733 MIL No	See Pg. 88 for Fig	Rated Voltage				I Amp	Min Cap $\mu$ F	DCR Max Ohms	CKT	Max L In	Max L (mm)	Thd Lgth	Minimum Insertion Loss (dB)							
			85°C		125°C									30 KHz	150 KHz	300 KHz	1 MHz	10 MHz	100 MHz	1 GHz	
			DC	AC	DC	AC															
51-444-040	25-0020	1	—	—	100		5.00	0.450	0.015	LB	0.738 (18.745)	B	6	17	23	35	69	70	70		
51-353-156	39-0009	1	—	—	100		10.00	0.450	0.003	LT	0.760 (19.304)	A	6	20	26	35	56	60	70		
51-353-157	39-0010	1	—	—	100		10.00	0.450	0.003	LB	0.760 (19.304)	A	6	20	26	35	56	60	70		
+ 51-353-076	26-0001	1	—	—	150	125	1.00	0.250	0.250	LT	0.758 (19.253)	A	—	13	24	45	80	70	70		
+ 51-353-077	26-0003	1	—	—	150	125	1.00	0.250	0.250	LB	0.738 (18.745)	A	—	13	24	45	80	70	70		
51-444-043	26-0013	1	—	—	150	125	1.00	0.250	0.250	LT	0.758 (19.253)	B	—	13	24	45	80	70	70		
51-444-044	26-0015	1	—	—	150	125	1.00	0.250	0.250	LB	0.738 (18.745)	B	—	13	24	45	80	70	70		
51-390-040	23-0058	1	—	—	150		2.00	0.250	0.070	LT	0.630 (16.002)	A	3	15	23	38	60	70	60		
51-390-039	23-0057	1	—	—	150		2.00	0.250	0.070	LT	0.630 (16.002)	B	3	15	23	38	60	70	60		
51-444-005	34-0015	1	—	—	150	125	3.00	0.150	0.050	LT	0.758 (19.253)	B	—	8	15	30	68	70	70		
+ 51-353-078	26-0004	1	—	—	150	125	3.00	0.250	0.050	LT	0.758 (19.253)	A	—	8	15	30	68	70	70		
+ 51-353-079	26-0006	1	—	—	150	125	3.00	0.250	0.050	LB	0.738 (18.745)	A	—	8	15	30	68	70	70		
+ 51-444-046	26-0018	1	—	—	150	125	3.00	0.250	0.050	LB	0.738 (18.745)	B	—	8	15	30	68	70	70		
51-444-047	26-0019	1	—	—	150	125	5.00	0.250	0.015	LT	0.758 (19.253)	B	—	8	14	25	58	70	70		
+ 51-353-080	26-0007	1	—	—	150	125	5.00	0.250	0.015	LT	0.758 (19.253)	A	—	8	14	25	58	70	70		
51-353-081	26-0010	1	—	—	150	125	5.00	0.250	0.015	LB	0.738 (18.745)	A	—	8	14	25	58	70	70		
51-444-027	34-0030	1	—	—	200	125	5.00	0.250	0.150	LB	0.900 (22.860)	A	2	15	21	32	60	70	70		
51-444-117	54-0018	2	—	—	300	125	1.00	0.150	0.250	LB	0.740 (18.796)	A	—	10	21	41	70	70	70		

† Also available through Spectrum Control's authorized distributors.

# Hermetically Sealed Threaded Case Filters



## .375 ø Pi Circuit

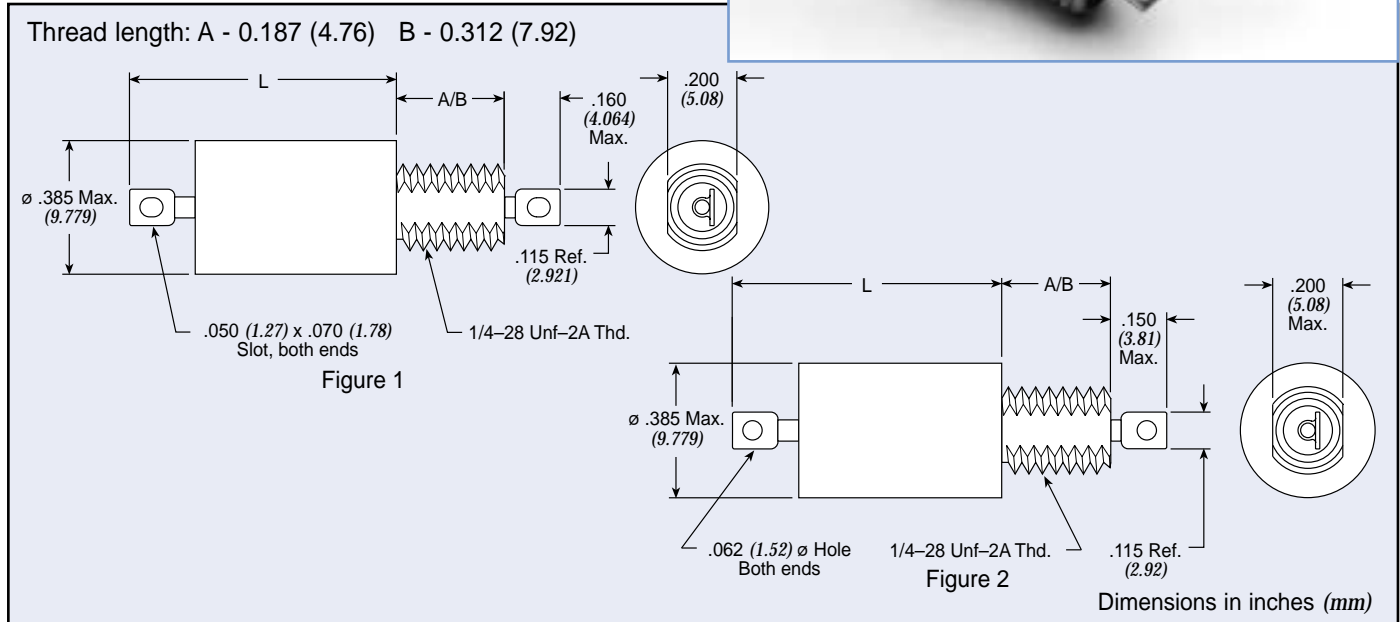

## .375 ø Pi Circuit Standard Product

Part Number	MIL No	Figure	Rated Voltage				I Amp	Min Cap µF	DCR Max Ohms	Max L		Thd Lgth	Minimum Insertion Loss (dB)						
			85°C		125°C					In	(mm)		30 KHz	150 KHz	300 KHz	1 MHz	10 MHz	100 MHz	1 GHz
			DC	AC	DC	AC													
SCI-2030-010	—	2	80	—	50	—	0.50	1.500	1.000	0.758	(19.253)	B	24	66	70	70	70	70	
SCI-2030-004	—	2	80	—	50	—	1.00	1.500	0.250	0.758	(19.253)	A	15	54	70	70	70	70	
SCI-2030-005	—	2	80	—	50	—	2.00	1.500	0.063	0.758	(19.253)	A	—	45	62	70	70	70	
SCI-2030-006	—	2	80	—	50	—	3.00	1.500	0.027	0.758	(19.253)	A	—	35	55	70	70	70	
SCI-2030-013	—	2	80	—	50	—	3.00	1.500	0.027	0.758	(19.253)	B	—	35	55	70	70	70	
†9001-100-1080	—	1	80	—	50	—	5.00	2.800	0.015	0.758	(19.253)	A	—	18	60	70	70	70	
†9001-100-1081	—	1	80	—	50	—	10.0	2.800	0.005	0.758	(19.253)	A	21	32	40	35	68	70	70
SCI-2130-009	—	1	150	—	100	—	0.25	1.000	4.000	0.758	(19.253)	B	28	70	70	70	70	70	
51-311-319	—	1	150	—	100	—	0.50	1.000	0.600	0.758	(19.253)	A	—	51	69	70	70	70	
†9001-100-1010	—	1	150	—	100	—	0.50	1.000	0.600	0.758	(19.253)	A	6	39	68	70	70	70	
51-311-320	—	1	150	—	100	—	1.00	1.000	0.250	0.758	(19.253)	A	—	41	60	70	70	70	
†9001-100-1013	—	1	150	—	100	—	1.00	1.000	0.250	0.758	(19.253)	A	—	28	59	70	70	70	
51-311-321	—	1	150	—	100	—	3.00	1.000	0.060	0.758	(19.253)	A	—	16	41	70	70	70	
†51-311-322	—	1	150	—	100	—	5.00	1.000	0.015	0.758	(19.253)	A	—	—	28	65	70	70	
SCI-2130-007	—	1	150	—	100	—	10.0	1.000	0.003	0.758	(19.253)	A	9	24	29	40	70	70	
SCI-2130-014	—	1	150	—	100	—	10.0	1.000	0.005	0.758	(19.253)	B	9	24	29	40	70	70	
51-311-316	—	1	250	125	200	125	1.00	0.300	0.250	0.758	(19.253)	A	—	20	40	70	70	70	
51-311-317	—	1	250	125	200	125	3.00	0.300	0.050	0.758	(19.253)	A	—	—	20	55	70	70	
†9001-100-1025	—	1	250	125	200	125	5.00	0.300	0.015	0.758	(19.253)	A	—	—	12	50	70	70	80
SCI-2330-009	—	1	300	125	300	125	0.25	0.300	4.000	0.758	(19.253)	B	8	50	66	70	70	70	
SCI-2330-010	—	1	300	125	300	125	0.50	0.300	1.000	0.758	(19.253)	B	—	40	56	70	70	70	
SCI-2330-012	—	1	300	125	300	125	2.00	0.300	0.063	0.758	(19.253)	B	—	18	33	63	70	70	
SCI-2330-007	—	1	300	125	300	125	10.0	0.300	0.003	0.758	(19.253)	A	—	14	20	30	70	70	

† Also available through Spectrum Control's authorized distributors.

# Hermetically Sealed Threaded Case Filters

## .375 ø Pi Circuit MIL Qualified Product

(See MIL index on pages 237-239 for complete MIL part number listing)

Part Number	M15733 MIL No	See Pg. 91 for Fig.	Rated Voltage				I Amp	Min Cap µF	DCR Max Ohms	Max L		Thd Lgth	Minimum Insertion Loss (dB)						
			85°C		125°C					In	(mm)		30 KHz	150 KHz	300 KHz	1 MHz	10 MHz	100 MHz	1 GHz
			DC	AC	DC	AC													
51-390-305	23-0017	1	—	—	50	—	0.30	2.800	0.770	0.730	(18.542)	B	29	73	80	80	80	80	
51-390-314	23-0042	1	—	—	50	—	1.00	2.800	0.140	0.730	(18.542)	A	8	52	71	80	80	80	80
† 51-390-318	23-0054	1	—	—	50	—	2.00	1.500	0.070	0.730	(18.542)	A	—	46	65	80	80	80	80
† 51-390-317	23-0053	1	—	—	50	—	2.00	1.500	0.070	0.730	(18.542)	B	—	46	65	80	80	80	80
51-311-311	25-0010	1	—	—	100	—	0.25	0.900	1.500	0.793	(20.142)	A	—	48	66	80	80	80	70
† 51-311-308	25-0002	1	—	—	100	—	1.00	0.500	0.250	0.793	(20.142)	A	—	33	52	80	80	80	70
† 51-311-309	25-0004	1	—	—	100	—	3.00	0.660	0.050	0.793	(20.142)	A	—	17	34	68	80	80	70
† 51-311-310	25-0006	1	—	—	100	—	5.00	0.900	0.015	0.793	(20.142)	A	—	—	17	57	80	80	70
51-353-344	39-0011	1	—	—	100	—	10.0	0.990	0.003	0.760	(19.304)	A	9	24	29	40	70	70	70
51-353-345	39-0012	1	—	—	100	—	10.0	0.990	0.003	0.760	(19.304)	A	9	24	29	40	70	70	70
† 51-311-314	26-0011	1	—	—	150	125	0.25	0.300	1.500	0.793	(20.142)	A	—	29	47	70	80	80	70
51-390-312	23-0036	1	—	—	150	—	0.50	0.500	0.360	0.730	(18.542)	A	—	48	66	70	70	70	70
51-390-311	23-0035	1	—	—	150	—	0.50	0.500	0.360	0.730	(18.542)	B	—	48	66	70	70	70	70
† 51-353-336	26-0002	1	—	—	150	125	1.00	0.300	0.250	0.793	(20.142)	A	—	11	32	63	80	80	70
51-390-315	23-0047	1	—	—	150	—	1.00	0.500	0.140	0.730	(18.542)	B	—	32	51	70	70	70	70
51-311-312	26-0005	1	—	—	150	125	3.00	0.300	0.050	0.793	(20.142)	A	—	5	6	47	80	80	70
51-311-408	54-0005	2	—	—	300	115	1.00	0.300	0.250	0.761	(19.329)	A	—	23	43	70	70	70	70

† Also available through Spectrum Control's authorized distributors.

Low Pass Filters

## Transient Suppression Pi Filters

Part Number	See Pg. 91 for Fig.	Rated Volt. VDC	I Amp	Min Cap µF	DCR Min Mohms	Max RDC Ohms	Transient Suppressor*				Length		Max Thd Lgth	Minimum Insertion Loss (dB)					
							VR* (VDC)	BV* (VDC)	IT* (MA)	IPP* (A)	In	(mm)		30 KHz	300 KHz	1 MHz	10 MHz	100 MHz	1 GHz
51-570-300	1	5	0.50	1.400	0.500	0.600	6.5	7.22/7.98	10	44.7	1.179	(29.947)	A	23	57	70	70	70	70
51-570-301	1	5	1.00	1.400	0.500	0.350	6.5	7.22/7.98	10	44.7	1.179	(29.947)	A	3	47	70	70	70	70
51-570-302	1	5	3.00	1.400	0.500	0.060	6.5	7.22/7.98	10	44.7	1.179	(29.947)	A	—	23	58	70	70	70
51-570-303	1	5	5.00	1.400	0.500	0.015	6.5	7.22/7.98	10	44.7	1.179	(29.947)	A	—	17	48	70	70	70
51-570-304	1	5	10.00	1.400	0.500	0.005	6.5	7.22/7.98	10	44.7	1.179	(29.947)	A	16	26	35	40	60	70
51-570-310	1	28	0.50	1.400	30.000	0.600	33.0	36.7/40.6	1	9.4	1.179	(29.947)	A	23	57	70	70	70	70
51-570-311	1	28	1.00	1.400	30.000	0.350	33.0	36.7/40.6	1	9.4	1.179	(29.947)	A	3	47	70	70	70	70
51-570-312	1	28	3.00	1.400	30.000	0.060	33.0	36.7/40.6	1	9.4	1.179	(29.947)	A	—	23	58	70	70	70
51-570-313	1	28	5.00	1.400	30.000	0.015	33.0	36.7/40.6	1	9.4	1.179	(29.947)	A	—	17	48	70	70	70
51-570-314	1	28	10.00	1.400	30.000	0.005	33.0	36.7/40.6	1	9.4	1.179	(29.947)	A	16	26	35	40	60	70
51-570-320	1	50	0.50	1.400	50.000	0.600	58.0	64.4/71.2	1	5.3	1.179	(29.947)	A	23	57	70	70	70	70
51-570-321	1	50	1.00	1.400	50.000	0.350	58.0	64.4/71.2	1	5.3	1.179	(29.947)	A	3	47	70	70	70	70
51-570-322	1	50	3.00	1.400	50.000	0.060	58.0	64.4/71.2	1	5.3	1.179	(29.947)	A	—	23	58	70	70	70
51-570-323	1	50	5.00	1.400	50.000	0.015	58.0	64.4/71.2	1	5.3	1.179	(29.947)	A	—	17	48	70	70	70
51-570-324	1	50	10.00	1.400	50.000	0.005	58.0	64.4/71.2	1	5.3	1.179	(29.947)	A	16	26	35	40	60	70

\* Transient Suppression definitions and ratings

VR = Reverse standoff voltage  
BV = Breakdown voltage

IPP = Max. peak pulse current  
IT = Test current

# Hermetically Sealed Threaded Case Filters



## .375 ø T Circuit

Thread length: A - 0.187 (4.76) B - 0.312 (7.92)

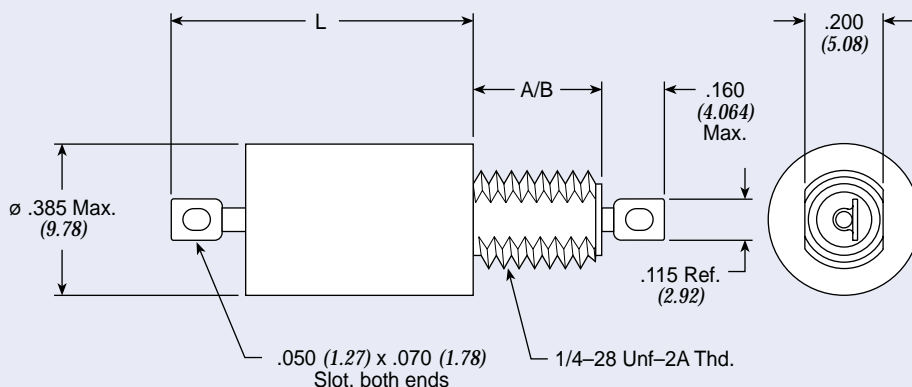

Figure 1

Note: Max. O.D. is ø .416" for Military QPL Filters.

Dimensions in inches (mm)

## .375 ø T Circuit Standard Product

Part Number	MIL No	Figure	Rated Voltage				I Amp	Min Cap µF	DCR Max Ohms	Max L		Thd Lgth	Minimum Insertion Loss (dB)						
			85°C		125°C					In	(mm)		30 KHz	150 KHz	300 KHz	1 MHz	10 MHz	100 MHz	1 GHz
SCI-2040-012	—	1	80	—	50	—	2.00	1.400	0.126	1.071	(27.203)	B	8	22	30	55	70	70	70
SCI-2040-013	—	1	80	—	50	—	3.00	1.400	0.054	1.071	(27.203)	B	8	22	28	43	70	70	70
† 9004-100-2017	—	1	80	—	50	—	15.0	1.400	0.005	1.179	(29.947)	A	17	27	34	44	60	70	70
SCI-2140-004	—	1	150	—	100	—	1.00	0.500	0.500	1.070	(27.178)	A	4	25	40	70	70	70	70
SCI-2140-006	—	1	150	—	100	—	3.00	0.500	0.054	1.071	(27.203)	A	4	19	24	39	70	70	70
SCI-2140-007	—	1	150	—	100	—	10.0	0.500	0.010	1.071	(27.203)	A	4	19	24	34	57	70	70
SCI-2340-009	—	1	300	—	300	125	0.25	0.150	8.000	1.071	(27.203)	B	11	57	70	70	70	70	70
SCI-2340-004	—	1	300	—	300	125	1.00	0.150	0.500	1.071	(27.203)	A	—	13	29	59	70	70	70
SCI-2340-013	—	1	300	—	300	125	3.00	0.150	0.054	1.071	(27.203)	B	—	8	14	29	70	70	70
SCI-2340-014	—	1	300	—	300	125	10.0	0.150	0.010	1.071	(27.203)	B	—	8	14	24	47	70	70

† Also available through Spectrum Control's authorized distributors.

## .375 ø T Circuit MIL Qualified Product

(See MIL index on page 237-239 for complete MIL part number listing)

Part Number	M15733 MIL No	Figure	Rated Voltage				I Amp	Min Cap µF	DCR Max Ohms	Max L		Thd Lgth	Minimum Insertion Loss (dB)						
			85°C		125°C					In	(mm)		30 KHz	150 KHz	300 KHz	1 MHz	10 MHz	100 MHz	1 GHz
51-382-609	25-0024	1	—	—	100	—	2.00	0.750	0.100	1.179	(29.947)	B	10	22	31	55	80	70	70
51-382-603	25-0007	1	—	—	100	—	4.00	0.750	0.063	1.345	(34.163)	A	10	22	28	43	80	70	70
† 51-351-604	26-0012	1	—	—	150	125	2.00	0.250	0.100	1.179	(29.947)	A	—	13	21	43	80	70	70
51-351-603	26-0008	1	—	—	150	125	4.00	0.250	0.063	1.345	(34.163)	A	—	11	18	33	80	70	70

† Also available through Spectrum Control's authorized distributors.

# Hermetically Sealed Threaded Case Filters

## .375 ø TT Circuit Standard Product

Part Number	MIL No	See Pg. 93 for Fig.	Rated Voltage				I Amp	Min Cap $\mu$ F	DCR Max Ohms	Max L		Thd Lgth	Minimum Insertion Loss (dB)						
			85°C		125°C					In	(mm)		30 KHz	150 KHz	300 KHz	1 MHz	10 MHz	100 MHz	1 GHz
			DC	AC	DC	AC													
SCI-2060-009	—	1	—	—	50	—	0.25	1.500	12.000	1.241	(31.521)	B	70	70	70	70	70	70	70
SCI-2060-013	—	1	—	—	50	—	3.00	1.500	0.081	1.241	(31.521)	B	—	33	54	70	70	70	70
SCI-2060-007	—	1	—	—	50	—	10.0	1.500	0.006	1.241	(31.521)	A	15	29	35	42	55	70	70
SCI-2060-014	—	1	—	—	50	—	10.0	1.500	0.006	1.241	(31.521)	B	15	29	35	42	55	70	70
SCI-2160-011	—	1	—	—	100	—	1.00	1.500	0.750	1.241	(31.521)	B	12	52	70	70	70	70	70
SCI-2160-012	—	1	—	—	100	—	2.00	1.500	0.189	1.241	(31.521)	B	—	33	56	70	70	70	70
SCI-2160-013	—	1	—	—	100	—	3.00	1.500	0.081	1.241	(31.521)	B	—	24	54	70	70	70	70
SCI-2160-014	—	1	—	—	100	—	10.0	1.400	0.006	1.241	(31.521)	B	12	25	32	42	55	70	70
SCI-2360-011	—	1	—	—	300	125	1.00	0.500	0.750	1.241	(31.521)	B	—	48	70	70	70	70	70
SCI-2360-006	—	1	—	—	300	125	3.00	0.500	0.080	1.241	(31.521)	A	—	12	38	70	70	70	70
SCI-2360-007	—	1	—	—	300	125	10.0	0.500	0.006	1.241	(31.521)	A	5	18	24	34	55	70	70
SCI-2360-014	—	1	—	—	300	125	10.0	0.500	0.006	1.241	(31.521)	B	5	18	24	34	55	70	70

# Hermetically Sealed Threaded Case Filters



## .690 ø C Circuit

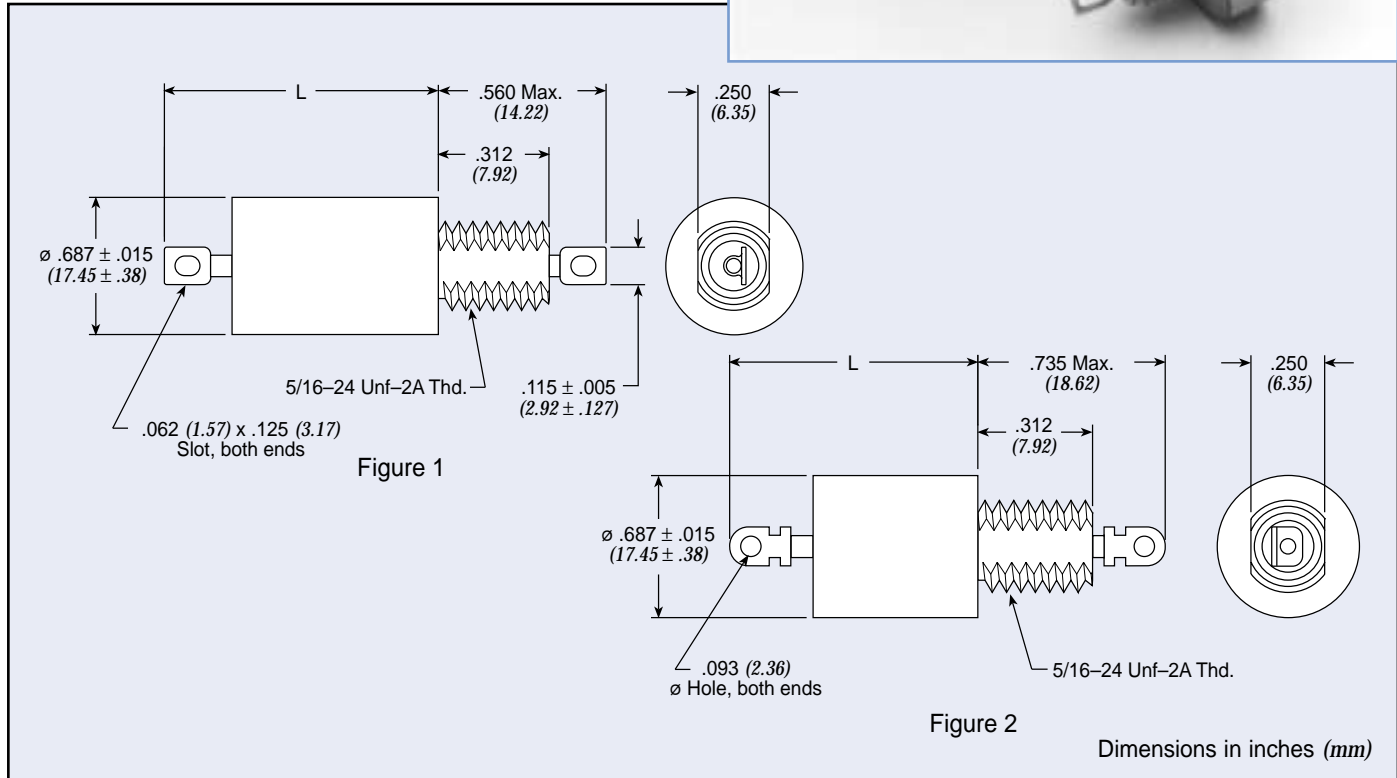

## .690 ø C Circuit Standard Product

Part Number	MIL No	Figure	Rated Voltage				I Amp	Min Cap $\mu$ F	DCR Max Ohms	Max L		Minimum Insertion Loss (dB)						
			85°C		125°C					In	L (mm)	30 KHz	150 KHz	300 KHz	1 MHz	10 MHz	100 MHz	1 GHz
			DC	AC	DC	AC												
† 9932-100-6004	—	1	200	—	150	—	15	2.600	0.005	0.702	(17.831)	10	29	39	50	60	70	70
54-310-001	—	1	300	—	300	125	15	0.500	0.005	0.560	(14.224)	6	19	25	36	50	70	70
54-310-005	—	2	250	—	200	125	25	0.500	0.005	0.750	(19.050)	6	19	25	36	50	70	70
54-310-009	—	1	450	240	400	240	15	0.250	0.005	0.560	(14.224)	—	14	19	30	45	60	70
† 9932-100-6005	—	1	450	240	400	240	15	0.250	0.005	0.560	(14.224)	—	14	19	30	50	70	70

## .690 ø C Circuit MIL Qualified Product

Part Number	M15733 MIL No	Figure	Rated Voltage				I Amp	Min Cap $\mu$ F	DCR Max Ohms	Max L		Minimum Insertion Loss (dB)						
			85°C		125°C					In	L (mm)	30 KHz	150 KHz	300 KHz	1 MHz	10 MHz	100 MHz	1 GHz
			DC	AC	DC	AC												
54-310-039	34-0037	1	—	—	275	125	15	0.200	0.005	0.575	(14.605)	5	15	21	31	51	70	70

## .690 ø C Circuit DSCC 84084 Product

Part Number	84084 No	Figure	Rated Voltage				I Amp	Min Cap $\mu$ F	DCR Max Ohms	Max L		Minimum Insertion Loss (dB)						
			85°C		125°C					In	L (mm)	30 KHz	150 KHz	300 KHz	1 MHz	10 MHz	100 MHz	1 GHz
			DC	AC	DC	AC												
54-310-042	-001	1	—	—	400	230	15	0.150	0.005	0.700	(17.780)	—	10	16	26	40	52	70

† Also available through Spectrum Control's authorized distributors.

# Hermetically Sealed Threaded Case Filters



## .690 ø L Circuit

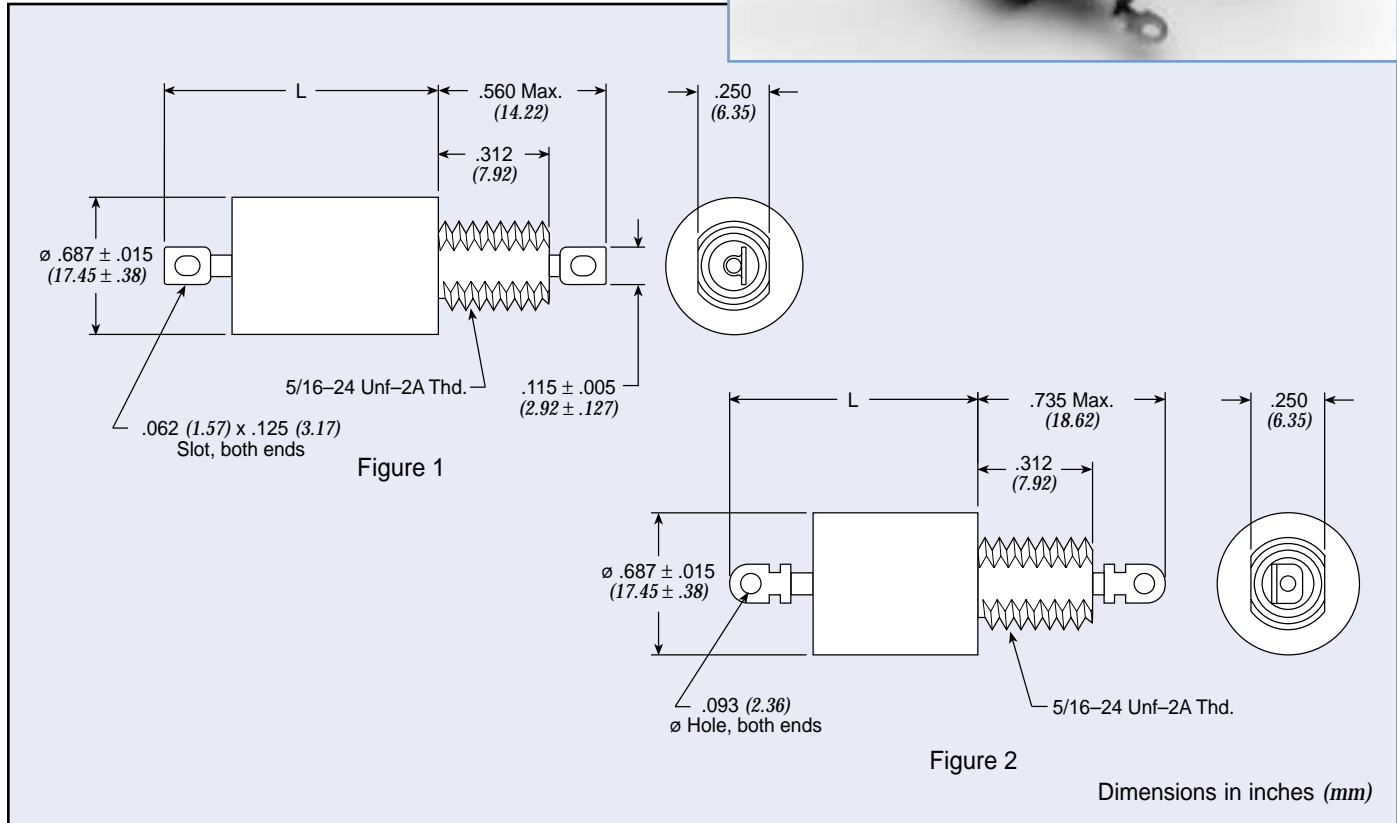

Low Pass Filters

## .690 ø L Circuit Standard Product

Part Number	MIL No	Figure	Rated Voltage				I Amp	Min Cap µF	DCR Max Ohms	CKT	Max L In	Max L (mm)	Minimum Insertion Loss (dB)						
			85°C		125°C								30 KHz	150 KHz	300 KHz	1 MHz	10 MHz	100 MHz	1 GHz
			DC	AC	DC	AC													
9010-100-0049	—	1	150	—	100	—	10.0	1.400	0.005	LT	0.905 (22.987)	16	24	34	44	60	70	70	
SCI-6120-008	—	1	150	—	100	—	10.0	2.600	0.006	LB	0.959 (24.359)	18	32	39	49	70	70	70	
SCI-6120-009	—	1	150	—	100	—	20.0	2.600	0.001	LB	0.905 (22.987)	18	32	39	49	60	70	70	
51-320-041	—	1	250	—	200	125	10.0	0.500	0.008	LT	0.905 (22.987)	5	19	25	35	50	70	70	
† 51-320-024	—	1	450	240	400	240	1.00	0.360	0.210	LT	0.905 (22.987)	5	30	38	60	70	70	70	
51-320-100	—	1	450	240	400	240	1.00	0.250	0.210	LT	0.905 (22.987)	—	21	33	55	70	70	70	
† 51-320-026	—	1	450	240	400	240	3.00	0.360	0.030	LT	0.905 (22.987)	5	19	25	45	70	70	70	
51-320-103	—	1	450	240	400	240	5.00	0.360	0.010	LB	0.905 (22.987)	—	12	18	30	60	70	70	
51-322-007	—	1	450	240	400	240	15.0	0.360	0.007	LB	0.650 (16.510)	5	19	25	35	48	62	70	
51-322-015	—	2	450	240	400	240	25.0	0.360	0.007	LT	0.750 (19.050)	5	17	23	34	48	62	70	
51-322-036	—	2	450	240	400	240	25.0	0.250	0.007	LB	0.750 (19.050)	—	10	16	29	45	60	70	
9010-100-0054	—	1	450	240	300	240	1.00	0.150	0.250	LT	0.905 (22.987)	—	14	32	52	70	70	70	
SCI-6320-004	—	1	300	—	300	125	1.00	0.400	0.300	LB	0.959 (24.359)	6	24	35	56	70	70	70	

† Also available through Spectrum Control's authorized distributors.

# Hermetically Sealed Threaded Case Filters

## L-C Filter LT

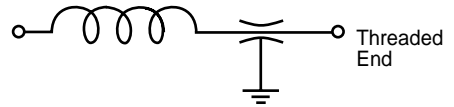

## L-C Filter LB

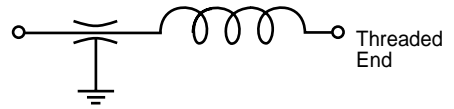

(See MIL index on page 237-239 for complete  
MIL part number listing)

### .690 ø L Circuit MIL Qualified Product

Part Number	M15733 MIL No	See Pg. 96 for Fig.	Rated Voltage				I Amp	Min Cap µF	DCR Max Ohms	CKT	Max L		Minimum Insertion Loss (dB)							
			85°C		125°C						In	(mm)	30	150	300	1	10	100	1	
			DC	AC	DC	AC							KHz	KHz	KHz	MHz	MHz	MHz	GHz	
† 51-320-015	27-0005	1	—	—	200	125	3.00	0.250	0.033	LT	0.900	(22.860)	—	14	21	39	80	70	70	
51-320-017	27-0008	1	—	—	200	125	5.00	0.250	0.016	LT	0.900	(22.860)	—	13	19	32	69	70	70	
51-320-018	27-0009	1	—	—	200	125	5.00	0.250	0.016	LB	0.900	(22.860)	—	13	19	32	69	70	70	
51-323-003	27-0011	1	—	—	200	125	10.0	0.250	0.005	LT	1.031	(26.187)	—	13	19	30	61	70	70	
51-323-004	27-0012	1	—	—	200	125	10.0	0.250	0.005	LB	1.031	(26.187)	—	13	19	30	61	70	70	
† 51-322-009	27-0014	2	—	—	200	125	15.0	0.250	0.007	LT	1.763	(44.780)	—	19	25	36	60	70	70	
51-322-017	34-0002	2	—	—	200	125	20.0	0.360	0.050	LB	1.763	(44.780)	—	19	25	35	57	70	70	

### .690 ø L Circuit DSCC 84084 Product

Part Number	84084 No	See Pg. 96 for Fig.	Rated Voltage				I Amp	Min Cap µF	DCR Max Ohms	CKT	Max L		Minimum Insertion Loss (dB)							
			85°C		125°C						In	(mm)	30	150	300	1	10	100	1	
			DC	AC	DC	AC							KHz	KHz	KHz	MHz	MHz	MHz	GHz	
51-320-162	-004	1	—	—	400	230	1.00	0.150	0.150	LT	0.905	(22.987)	—	19	30	46	60	70	70	
51-320-163	-005	1	—	—	400	230	1.00	0.150	0.150	LB	0.905	(22.987)	—	19	30	46	60	70	70	
51-320-164	-006	1	—	—	400	230	3.00	0.150	0.026	LT	0.905	(22.987)	—	11	19	36	60	70	70	
51-320-165	-007	1	—	—	400	230	3.00	0.150	0.026	LB	0.905	(22.987)	—	11	19	36	60	70	70	
51-320-166	-008	1	—	—	400	230	5.00	0.150	0.013	LT	0.905	(22.987)	—	10	16	28	54	70	70	
51-320-167	-009	1	—	—	400	230	5.00	0.150	0.013	LB	0.905	(22.987)	—	10	16	28	54	70	70	
51-320-168	-010	1	—	—	400	230	10.0	0.150	0.008	LT	0.905	(22.987)	—	10	16	25	48	70	70	
51-320-169	-011	1	—	—	400	230	10.0	0.150	0.008	LB	0.905	(22.987)	—	10	16	25	48	70	70	

† Also available through Spectrum Control's authorized distributors.

# Hermetically Sealed Threaded Case Filters

## .690 ø Pi Circuit

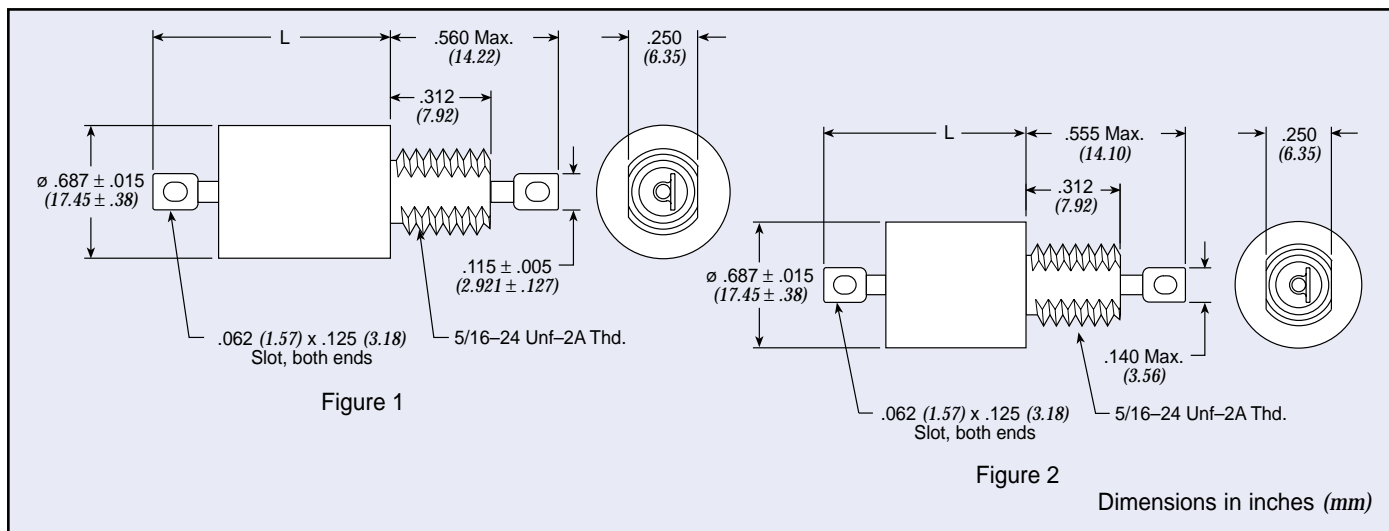

Low Pass Filters

## .690 ø Pi Circuit Standard Product

Part Number	MIL No	Figure	Rated Voltage				I Amp	Min Cap µF	DCR Max Ohms	Max L (mm)		Minimum Insertion Loss (dB)						
			85°C		125°C							30 KHz	150 KHz	300 KHz	1 MHz	10 MHz	100 MHz	1 GHz
			DC	AC	DC	AC						In	L					
51-321-322	—	1	150	—	100	—	1.00	2.800	0.210	1.195	(30.353)	35	69	70	70	70	70	70
SCI-6130-009	—	1	150	—	100	—	20.0	5.200	0.001	1.195	(30.353)	23	35	42	50	70	70	70
51-321-317	—	1	450	240	400	*240	1.00	0.720	0.400	1.195	(30.353)	—	53	70	70	70	70	70
†51-321-318	—	1	450	240	400	*240	3.00	0.720	0.030	1.195	(30.353)	—	31	51	70	70	70	70
†51-321-319	—	1	450	240	400	*240	5.00	0.720	0.020	1.195	(30.353)	—	11	30	65	70	70	70

\* 0-60 Hz

(See MIL index on page 237-239 for complete MIL part number listing)

## .690 ø Pi Circuit MIL Qualified Product

Part Number	M15733 MIL No	Figure	Rated Voltage				I Amp	Min Cap µF	DCR Max Ohms	Max L (mm)		Minimum Insertion Loss (dB)						
			85°C		125°C							30 KHz	150 KHz	300 KHz	1 MHz	10 MHz	100 MHz	1 GHz
			DC	AC	DC	AC						In	L					
51-321-312	27-0004	1	—	—	200	125	1.00	0.500	0.250	1.195	(30.353)	—	47	65	80	80	70	70
†51-323-313	27-0003	1	—	—	200	125	1.00	0.500	0.270	1.031	(26.187)	—	43	61	80	80	70	70
51-321-313	27-0010	1	—	—	200	125	5.00	0.500	0.024	1.195	(30.353)	—	10	28	64	80	70	70
†51-321-314	27-0013	1	—	—	200	125	10.0	0.500	0.008	1.195	(30.353)	—	16	18	48	80	70	70
51-321-329	34-0005	1	—	—	200	125	10.0	0.500	0.075	1.195	(30.353)	—	16	18	48	80	70	70

## .690 ø Pi Circuit DSCC 84084 Product

Part Number	84084 No	Figure	Rated Voltage				I Amp	Min Cap µF	DCR Max Ohms	Max L (mm)		Minimum Insertion Loss (dB)						
			85°C		125°C							30 KHz	150 KHz	300 KHz	1 MHz	10 MHz	100 MHz	1 GHz
			DC	AC	DC	AC						In	L					
51-321-398	-013	2	—	—	400	230	1.00	0.200	0.150	1.200	(30.480)	—	27	46	74	80	80	80
51-321-399	-014	2	—	—	400	230	3.00	0.200	0.026	1.200	(30.480)	—	—	30	60	80	80	80
51-321-400	-015	2	—	—	400	230	5.00	0.200	0.013	1.200	(30.480)	—	—	12	50	80	80	80
51-321-401	-016	2	—	—	400	230	10.0	0.200	0.008	1.200	(30.480)	—	—	—	30	80	80	80

† Also available through Spectrum Control's authorized distributors.

# Hermetically Sealed Threaded Case Filters

## .690 ø T Circuit

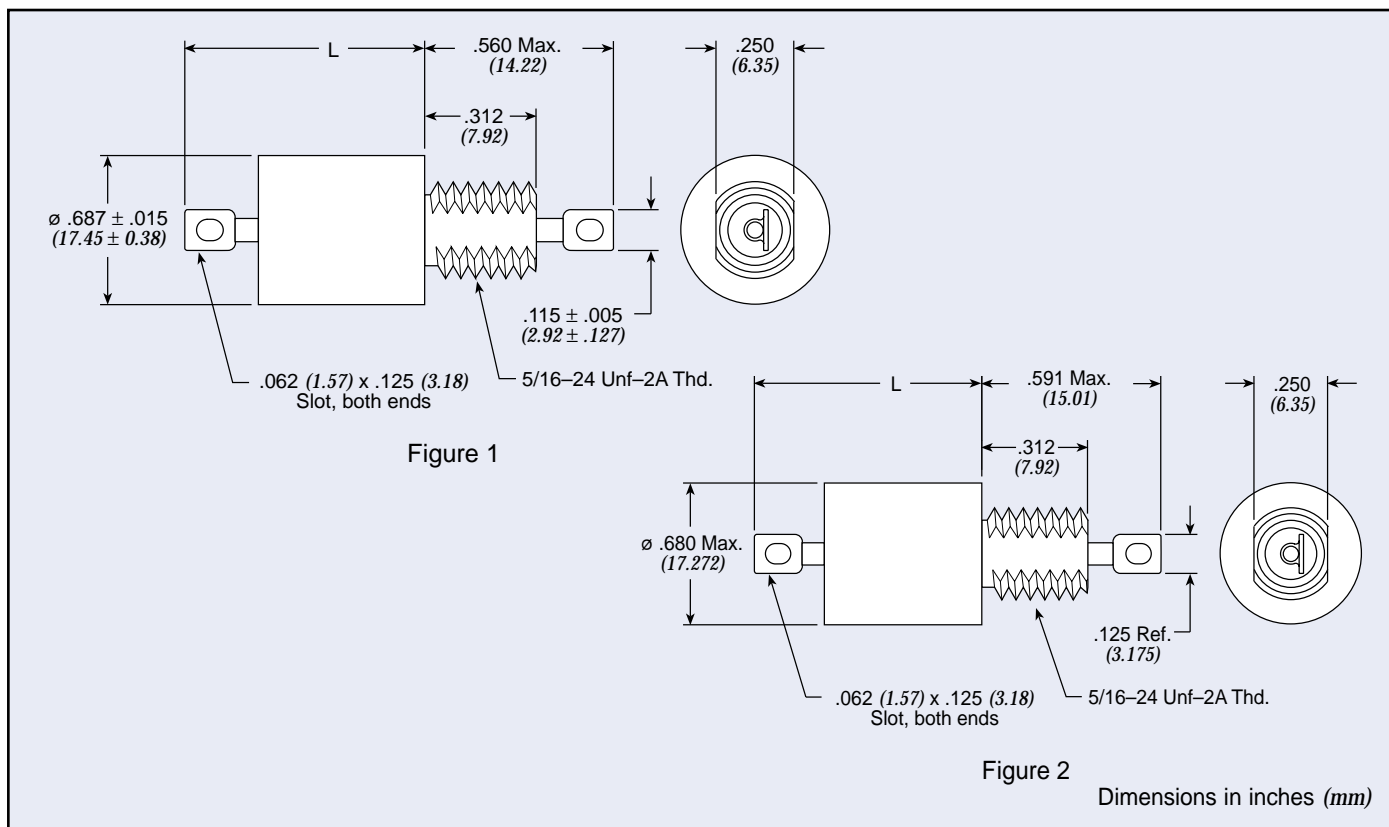

## .690 ø T Circuit Standard Product

Part Number	MIL No	Figure	Rated Voltage				I Amp	Min Cap $\mu$ F	DCR Max Ohms	Max L		Minimum Insertion Loss (dB)						
			85°C		125°C					In	L (mm)	30 KHz	150 KHz	300 KHz	1 MHz	10 MHz	100 MHz	1 GHz
			DC	AC	DC	AC						—	—	—	—	—	—	—
SCI-6140-004	—	1	150	—	100	—	1.00	2.600	0.600	1.195	(30.353)	23	54	70	70	70	70	70
SCI-6140-006	—	1	150	—	100	—	3.00	2.600	0.100	1.195	(30.353)	21	35	46	70	70	70	70
SCI-6140-007	—	1	150	—	100	—	5.00	2.600	0.060	1.195	(30.353)	21	34	41	58	70	70	70
SCI-6140-009	—	1	150	—	100	—	20.0	2.600	0.002	1.195	(30.353)	21	35	41	50	60	70	70
51-321-649	—	1	250	125	200	125	2.00	0.360	0.090	1.195	(30.353)	—	24	38	65	70	70	70
† 51-321-610	—	1	450	240	400	240	1.00	0.360	0.600	1.195	(30.353)	7	43	60	70	70	70	70

## .690 ø T Circuit MIL Qualified Product

(See MIL index on pages 237-239 for complete MIL part number listing)

Part Number	M15733 MIL No	Figure	Rated Voltage				I Amp	Min Cap $\mu$ F	DCR Max Ohms	Max L		Minimum Insertion Loss (dB)						
			85°C		125°C					In	L (mm)	30 KHz	150 KHz	300 KHz	1 MHz	10 MHz	100 MHz	1 GHz
			DC	AC	DC	AC						—	—	—	—	—	—	—
51-321-607	27-0017	1	—	—	200	125	1.50	0.250	0.133	1.195	(30.353)	—	19	32	62	70	70	70
51-321-608	27-0018	1	—	—	200	125	4.00	0.250	0.025	1.195	(30.353)	—	14	21	36	70	70	70
51-321-670	54-0017	2	—	—	300	115	10.0	0.500	0.006	1.177	(29.896)	5	20	23	35	60	70	60

† Also available through Spectrum Control's authorized distributors.

# Value-Added Low Pass Filter Assemblies

Spectrum Control's value-added low pass filters provide flexible solutions to meet your unique design challenges. Our manufacturing process allows you to add connectors, modify terminations or add wire harnesses without adding much cost or drastically increasing lead times.

For custom requirements and exceptional needs, contact our design/manufacturing team.

## Features

- Build-to-order low pass filters from Spectrum Control, Inc.
- Custom low pass filter assemblies

## Benefits

- Incorporates specific terminations, connectors or wire harnesses to accommodate your application
- Lowers the cost of acquisition and assembly
- Reduces production operations and lead times
- Allows you to stream line your bill of materials
- Reduces inventory/production costs



# Filtered Arrays

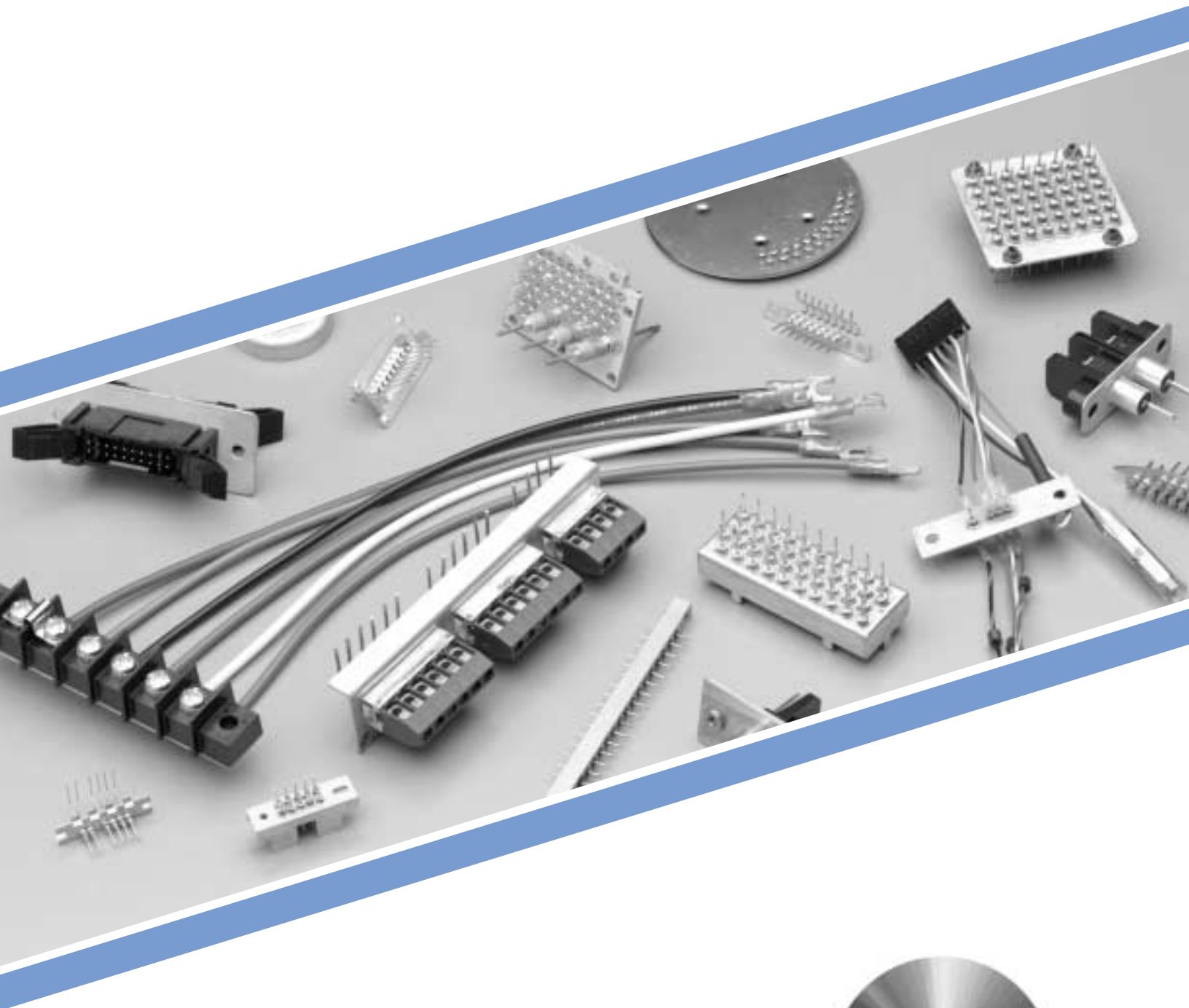

**ISO 9001**  
CERTIFIED



**SPECTRUM CONTROL INC.**  
A Control Products and Systems Company  
**Signal and Power Integrity Group**

# Filtered Array Selection Guide

## Easy Mate® Filter Plates

- Reduce installation time and overall cost
- Eliminate mounting hardware and prepwork
- Flexibility in mounting density, 0.100" and 2mm centers
- Multiple finger ground contacts provide excellent EMI filtering from 5 MHz to 18 GHz
- Maximize real estate on PCB
- Ideal for isolation of electronic compartments

The Easy Mate® & Easy Mate® Jr. filter plate family offer one of the most innovative EMI solutions in the electronic arena. The Easy Mate® concept of multiple finger ground contacts provides the lowest path of impedance for noise to ground.

The Easy Mate® family reduces your total installed cost by eliminating the need for prep work and hardware.

**Pages**  
*Easy Mate® Filter Plates* . . . . . 104-107  
*Easy Mate® Jr. Filter Plates* . . . . . 108-109

## Bolt-in Filter Plates

- Eliminate the need to mount filters into bulkheads
- Excellent filtering from 5 MHz to 1 GHz, outperforms surface mount filters over 50 MHz
- Mixed capacitance values and circuits
- Maximize real estate on PCB
- Total installed cost savings compared to discrete filters
- Ideal for isolation of electronic compartments

Bolt-in style filter plates provide an excellent method for electronic system interface and EMI filtering of signal and power lines. Bolt-in filter plates are available in a variety of plate sizes and up to 74 lines per plate in Hi-Density, and 60 pins per plate in standard density configuration.

*Bolt-in Filter Plates* . . . . . 110-113

## Custom Filter Plates & Terminal Blocks

- Custom assemblies with varying cable lengths and terminations
- Integrate with other functional devices to supply a complete turnkey assembly
- Perform EMC evaluations on complete equipment and identify proper placement of EMI/RFI filtering components
- Custom High Reliability assemblies

Spectrum Control offers a number of value added features designed to specifically meet your manufacturing needs. Spectrum Control can build and provide product that meets the most stringent High Reliability specifications.

*Shrouded Latch Filter Plates* . . . . . 114-115  
*Custom Filter Plates* . . . . . 116-117  
*Filter Selection* . . . . . 118  
*Filter Plate Design Inquiry Form* . . . . . 119  
*Custom Terminal Blocks* . . . . . 124  
*Terminal Block Design Inquiry Form* . . . . . 124

## Barrier Strip Filtered Terminal Blocks

- Rugged construction provides protection to filtering element
- 2 to 6 terminals in a single row available
- Cost effective solution for backplane EMI leakage problems
- 20 Amp rating
- UL recognized & CSA approved for DC voltages

The Barrier style terminal block is designed to provide excellent EMI filtering for both DC power and signal lines. These terminal blocks are available in sizes from 2 through 6 positions. Applications include power supplies in telecommunications equipment, metering, industrial controls, instrumentation and heavy equipment controls.

*Barrier Strip Filtered Terminal Blocks* . . . . . 120-121

## PCB Mount Filtered Terminal Blocks

- Fast and easy PCB installation and maintenance
- Cost effective solution for industrial interconnection EMI filtering problems
- Available with metric (5mm) or U.S. (.200") pin spacing
- 2 to 12 terminals available

The PCB terminal block is designed to provide excellent EMI filtering of low voltage DC power and signal/control lines. These terminal blocks use a screw clamp system with wire protector, which provides for quick and simple installation. Applications include power supplies in telecommunications equipment, metering, industrial controls, instrumentation and heavy equipment controls.

*PCB Mount Filtered Terminal Blocks* . . . . . 122-123

## Filter Plates

Eliminating EMI/RFI interference has become a stringently enforced matter and needs to be considered at the early stages of design for all electronic systems. Both internal and external interference sources have a major impact on the successful EMC performance of a new system.

Shielding alone is unsatisfactory in shunting unwanted harmonics, conducted or radiated, on power/ control lines that run through compartments of an electronic enclosure. This is particularly applicable in systems operating at frequencies above 50 MHz. Isolation and the incorporation of feed-thru filters (Filter Plates) to facilitate entering or leaving sensitive compartments in an assembly are excellent methods to bring electronic interdependent functions/systems into compliance.

Filter Plates allow a means of interfacing voltage and/or data (controlling instructions) to distant areas of a system without compromising its performance. Filter Plates provide excellent isolation from 5 MHz to 18 GHz and beyond, reduce the labor involved for installation, as well as reduce the risk of damaging filter elements during installation. Connecting to these Filter Plates is easily accomplished through several methods, either ribbon style connectors, harnesses, hard wiring or directly soldering leads at a 90° angle to the printed circuit board.

The drawings on pages 105, 111 and 115 illustrate how filter plates are incorporated into an electronic system.

### Filter Plate Advantages

- Provide an EMI filtered signal line between electronic system modules
- Reduce cost . . . economical method to meet EMC requirements
- Reduce labor . . . eliminate need to assemble filters into a bulkhead
- Outperform surface mount EMI filters at frequencies above 50 MHz
- Reduce risk of damage to filter elements due to thermal shock and installation
- Improve reliability . . . every filter plate is 100% tested for key parameters
- Maximize real estate on PCB
- Mixed schematics in a single filter plate package

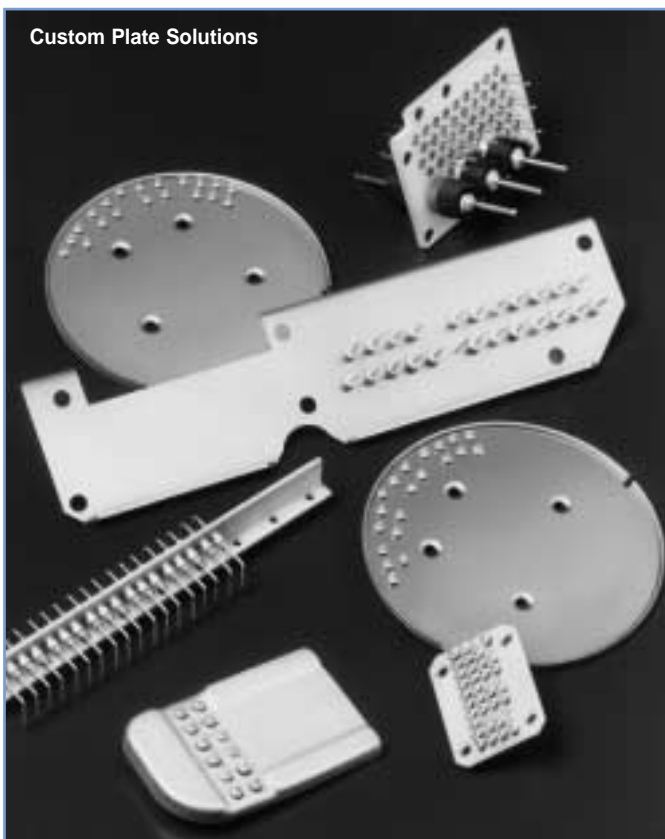
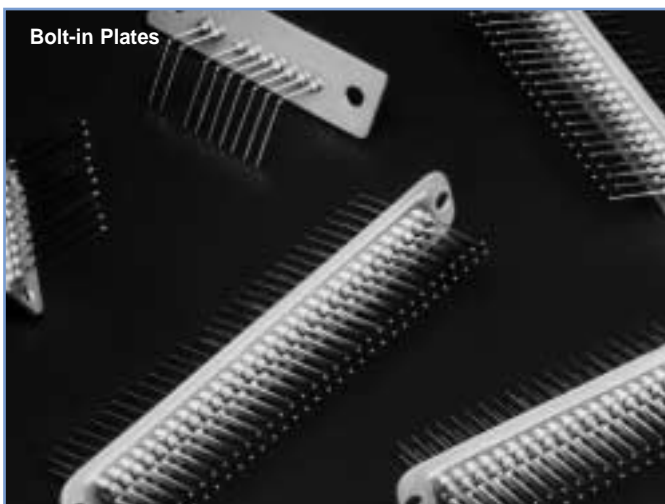
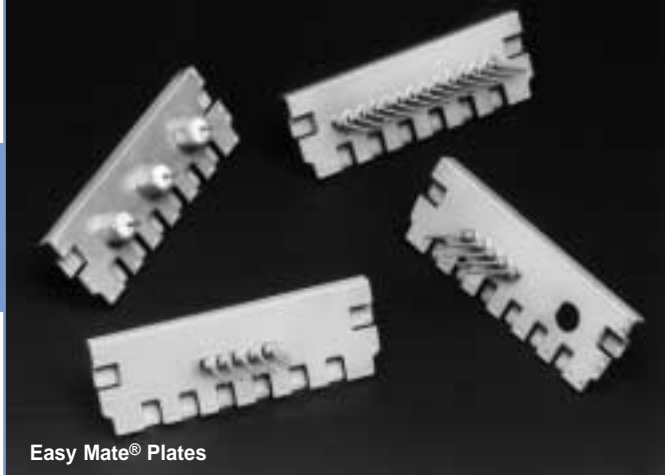

# Easy Mate® Filter Plates

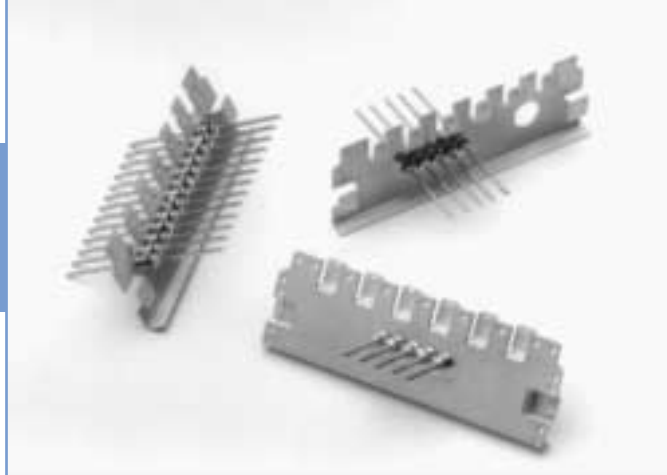

Spectrum Control developed a new EMI/RFI filter plate, Easy Mate®, which simplifies installation and eliminates the need for mounting hardware. The Easy Mate®, **patented**, is designed to “snap” into the chassis of electronic systems, reducing the labor required to complete a plate installation. The drawing on page 105 shows the Easy Mate® design.

These plates are available in two lengths and in both standard density centers (.100") and hi-density centers (2mm). Standard density Easy Mate® plates offer up to 26 lines per plate in a double row configuration, while hi-density plates offer up to 32 lines. Custom sizes for Easy Mate® plates are available.

## Easy Mate® Advantages

- Reduces installation time and overall cost
- Eliminates mounting hardware and prepwork
- Flexibility for 1 or 2 rows and standard density centers (.100") or hi-density centers (2mm)
- Improves overall quality and reliability
- Multiple dimpled finger ground contacts provides excellent long term EMI filtering from 5 MHz to 18 GHz
- Outperforms surface mount devices
- Maximize real estate on PCB
- Mixed capacitance values and schematics
- Ideal for isolation of electronic compartments

## Ordering Information

**Example: 52-898-206-B A 2**

The part number shown represents an Easy Mate® filter plate with 2 rows, 6 filters per row. Filters are C style with a capacitance value of 100pF. The plate length is 1.092", and the leads are bent 90° to the right side.

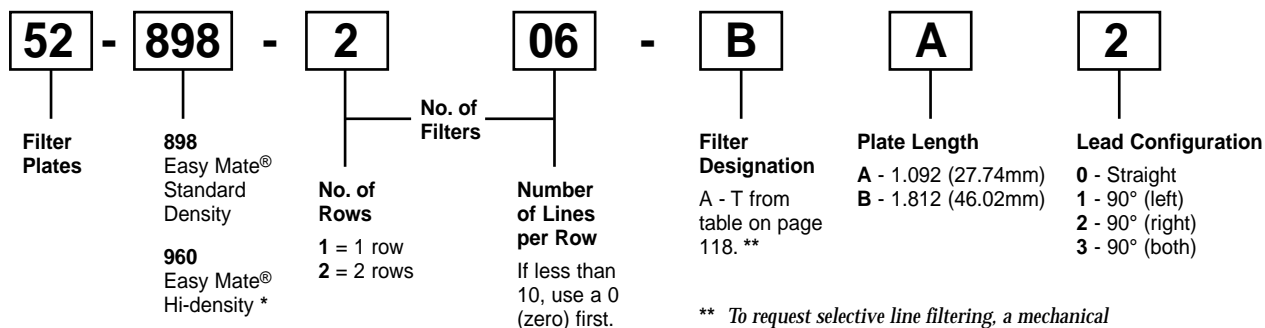

\* Maximum capacitance up to 4000pF C style filter

\*\* To request selective line filtering, a mechanical configuration or material specification not shown in this catalog, please complete and forward the design inquiry form on page 119. We will review your request and provide you with a part number.

# Easy Mate® Filter Plates

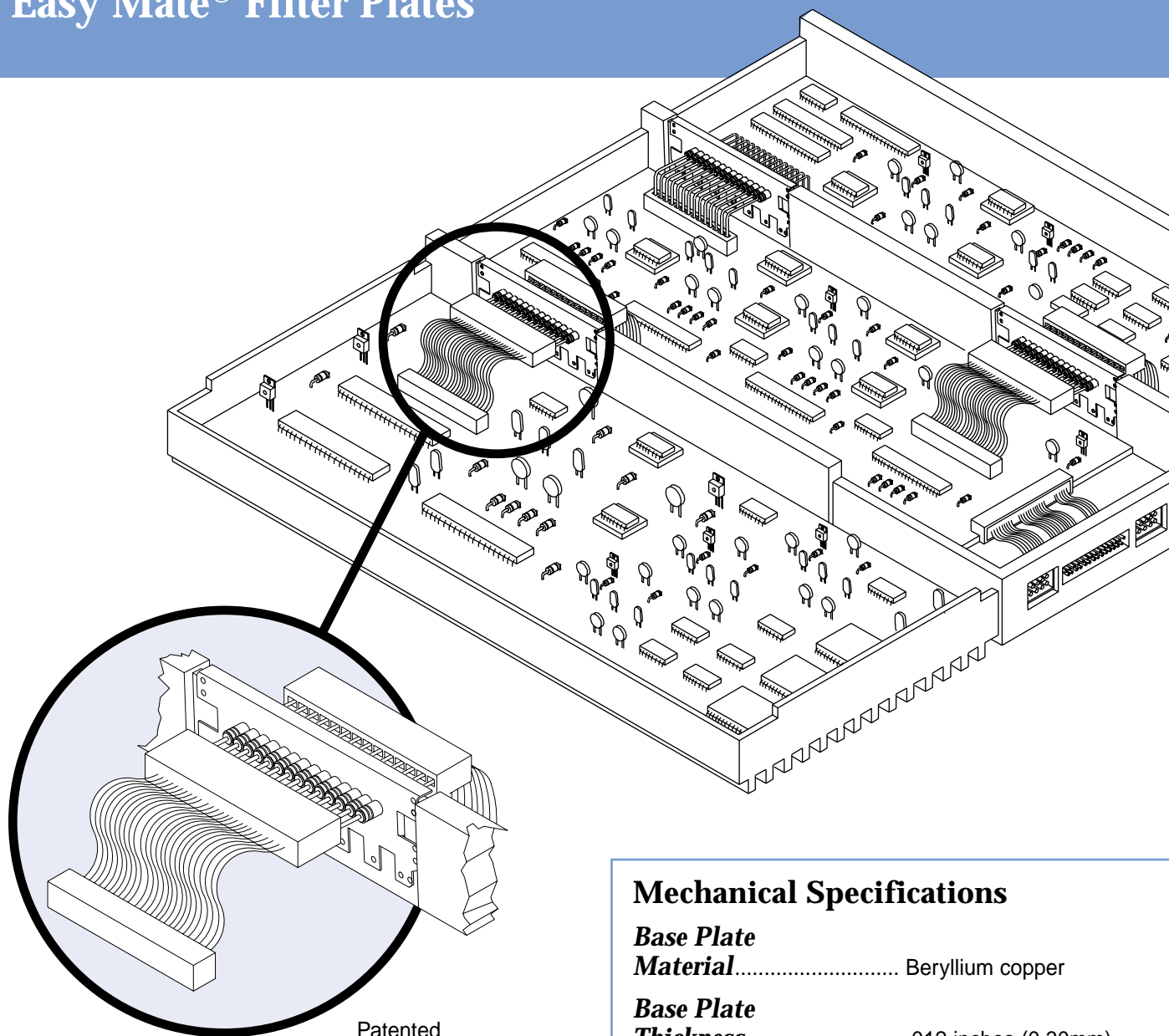

Patented

## Soldering to Filter Terminals

- Use a temperature controlled soldering iron with tip temperature of 525 ± 10° F (275 ± 5° C).
- Use an SN 63 RMA flux core solder.
- Make mechanical wire connection.
- Use heat sink next to filter body where possible.
- Clean soldering iron tip.
- Clip end of solder—remove 0.5" (12.7mm) to expose flux for soldering.
- Apply soldering iron to wire/flag junction at wetted solder tip region of iron (Wetted Bridge Method). Immediately apply solder. Dwell time for soldering iron tip on product should be 3-5 seconds maximum.

## Mechanical Specifications

<b>Base Plate</b>	
<b>Material</b> .....	Beryllium copper
<b>Base Plate</b>	
<b>Thickness</b> .....	.012 inches (0.30mm)
<b>Plating</b> .....	
	Tin
<b>Lead Material</b> .....	
	Copper alloy
<b>Lead Plating</b> .....	
	Gold plate
<b>Lead Diameter</b> .....	
	ø .025" (.64mm) for 0.100" centers (2.54mm)
	ø .020 (.51mm) for 0.079" centers (2.00mm)
<b>Current Rating</b> .....	
	5 Amps for .025" ø (.64mm)
	3 Amps for .020" ø (.51mm)

# Easy Mate® Filter Plates

## Standard Density Centers .100"

**Dimensions:** inches and (mm)  
**Lead Spacing:** .100" (2.54 mm)

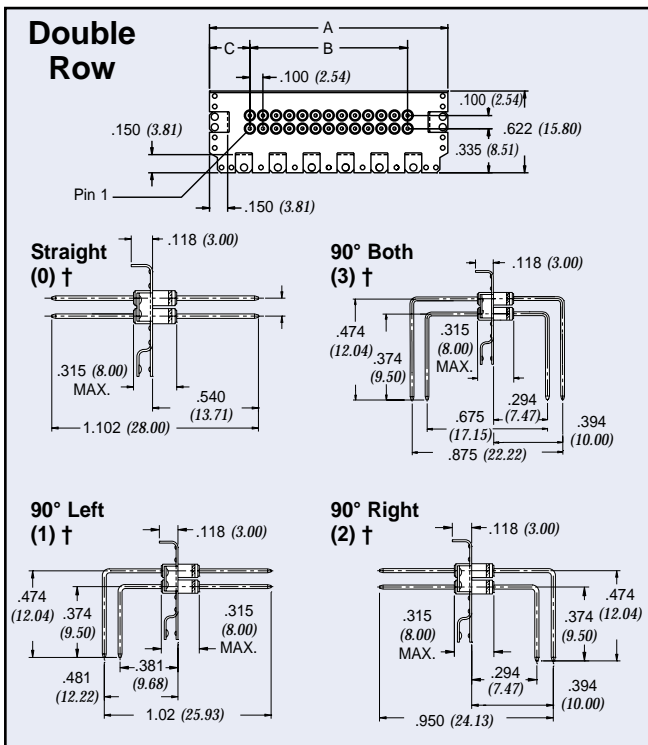
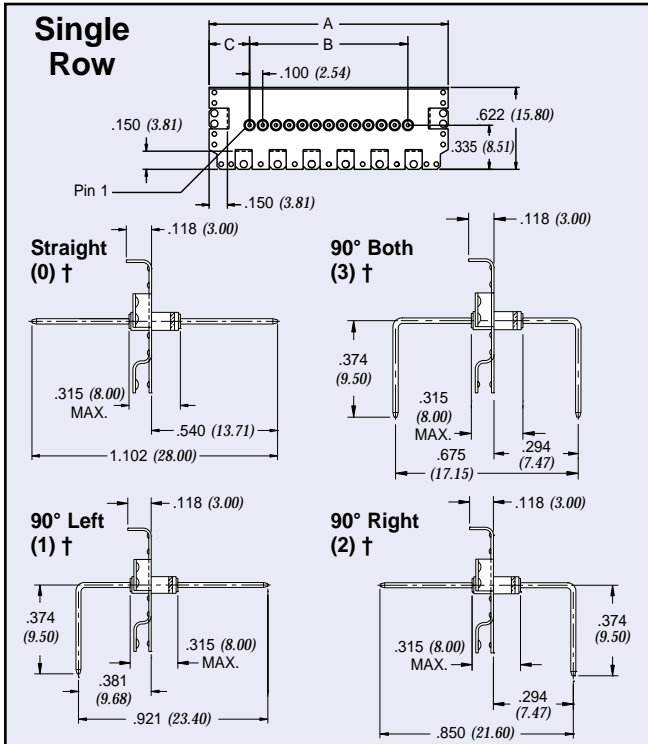
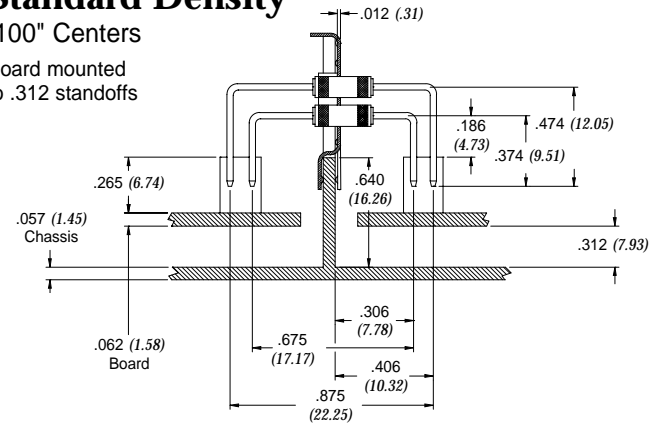

Plate length (A)	No. of filtered lines per row	52-898-XXX-XXX	
		B	C
1.092 (27.74)	1	0 (0.00)	0.496 (12.60)
	2	0.1 (2.54)	0.496 (12.60)
	3	0.2 (5.08)	0.396 (10.06)
	4	0.3 (7.62)	0.396 (10.06)
	5	0.4 (10.16)	0.296 (7.52)
	6	0.5 (12.70)	0.296 (7.52)
1.812 (46.02)	1	0 (0.00)	0.906 (23.01)
	2	0.1 (2.54)	0.806 (20.47)
	3	0.2 (5.08)	0.806 (20.47)
	4	0.3 (7.62)	0.706 (17.93)
	5	0.4 (10.16)	0.706 (17.93)
	6	0.5 (12.70)	0.606 (15.39)
	7	0.6 (15.24)	0.606 (15.39)
	8	0.7 (17.78)	0.506 (12.85)
	9	0.8 (20.32)	0.506 (12.85)
	10	0.9 (22.86)	0.406 (10.31)
	11	1.0 (25.40)	0.406 (10.31)
	12	1.1 (27.94)	0.306 (7.77)
	13	1.2 (30.48)	0.306 (7.77)

## Typical Mounting Applications

### Standard Density .100" Centers

Board mounted to .312 standoffs



### Hi-Density 2mm Centers

Board mounted to .312 standoffs

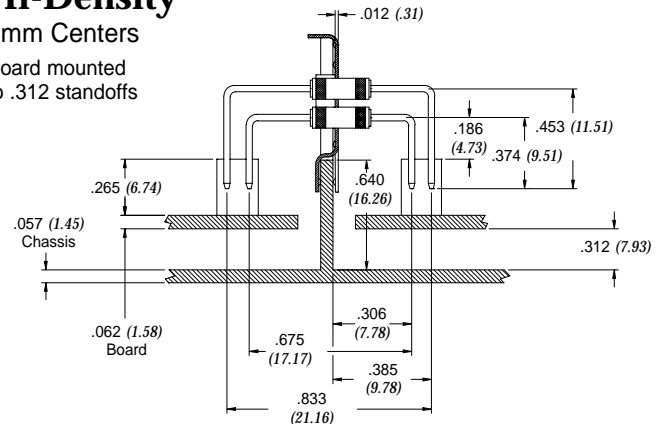

Patented  
 † Refers to lead configuration for part number/ordering information

# Easy Mate® Filter Plates

## Hi-Density Centers 2mm

**Dimensions:** inches and (mm)  
**Lead Spacing:** .079" (2.00 mm)

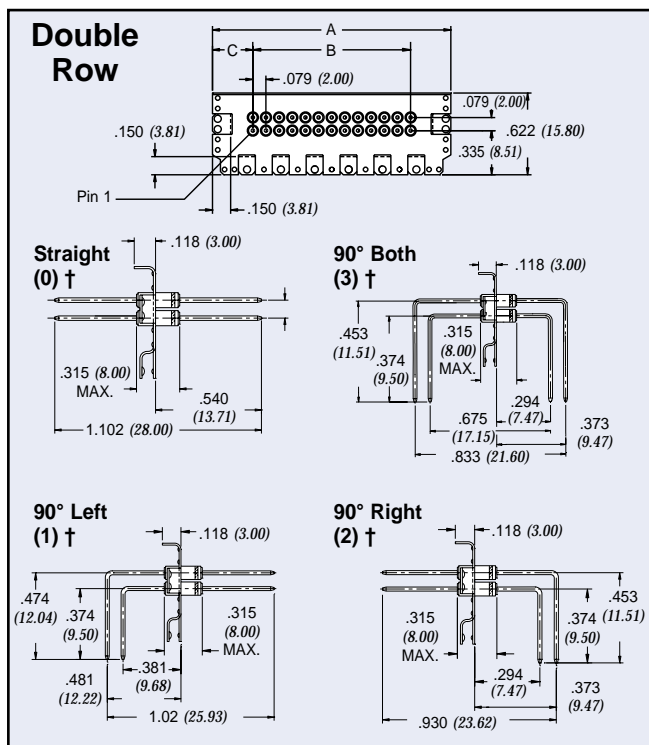
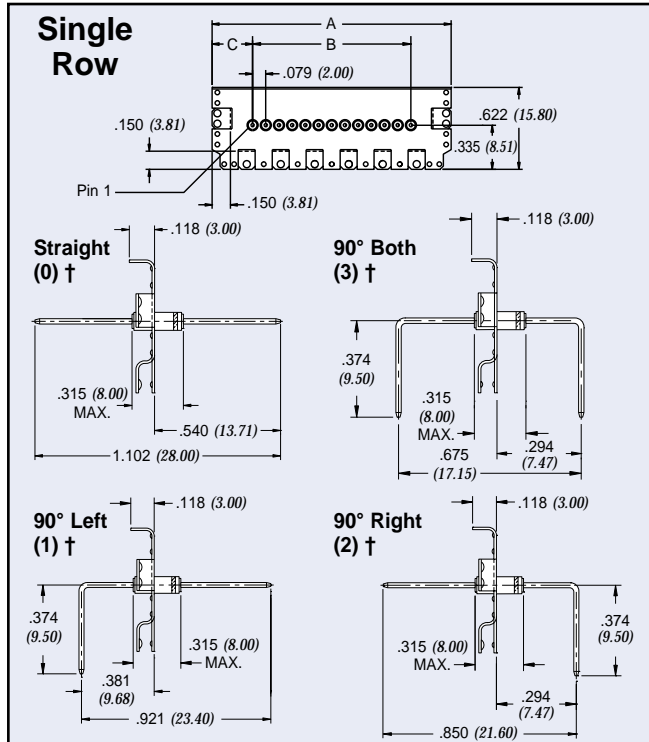

Patented  
 † Refers to lead configuration for part number/ordering information

Plate length (A)	No. of filtered lines per row	52-960-XXX-XXX	
		B	C
1.092 (27.74)	2	0.079 (2.00)	0.463 (11.77)
	3	0.157 (4.00)	0.463 (11.77)
	4	0.236 (6.00)	0.385 (9.77)
	5	0.315 (8.00)	0.385 (9.77)
	6	0.394 (10.00)	0.306 (7.77)
1.812 (46.02)	7	0.472 (12.00)	0.306 (7.77)
	2	0.079 (2.00)	0.866 (22.00)
	3	0.157 (4.00)	0.787 (20.00)
	4	0.236 (6.00)	0.787 (20.00)
	5	0.315 (8.00)	0.709 (18.00)
	6	0.394 (10.00)	0.709 (18.00)
	7	0.472 (12.00)	0.630 (16.00)
	8	0.551 (14.00)	0.630 (16.00)
	9	0.630 (16.00)	0.551 (14.00)
	10	0.709 (18.00)	0.551 (14.00)
	11	0.787 (20.00)	0.472 (12.00)
12	0.866 (22.00)	0.472 (12.00)	
13	0.945 (24.00)	0.394 (10.00)	
14	1.024 (26.00)	0.394 (10.00)	
15	1.102 (28.00)	0.315 (8.00)	
16	1.181 (30.00)	0.315 (8.00)	

### Easy Mate® Chassis Cut-out Design

Patent Pending

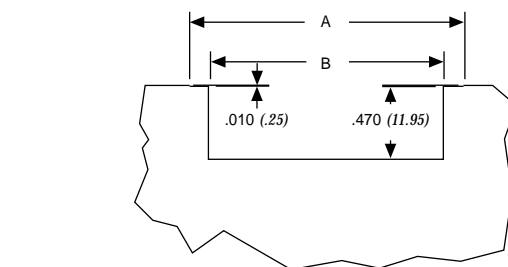
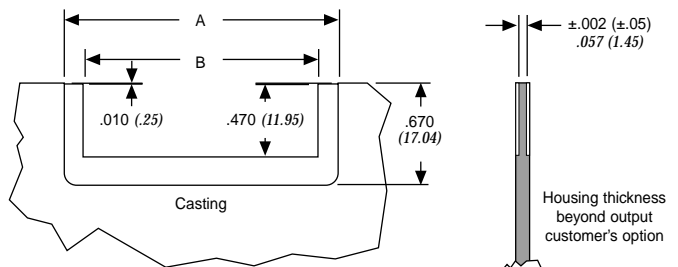

Plate Length	B	C
1.092 (27.74)	1.117 (28.41)	0.816 (20.75)
1.812 (46.02)	1.837 (46.71)	1.535 (39.04)

Filtered Arrays

# Easy Mate® Jr. Filter Plates

Spectrum Control has expanded its popular Easy Mate® family by adding two more package sizes. These new sizes are lower profile and facilitate installation of feed-thru filters into small hardware applications such as PCS linear power amplifiers and RF transmitters. The Easy Mate® Jr. is available in two plate lengths .990" and 1.240" and in standard (.100") and high density centers (2mm).

## Easy Mate® Jr. Advantages

- Reduces installation time and overall cost
- Eliminates mounting hardware and prepwork
- Increase flexibility with standard density centers (.100") or high density centers (2mm)
- Improves overall quality and reliability
- Multiple finger ground contacts provide excellent EMI filtering from 5 MHz to 18 GHz
- Outperforms surface mount devices
- Maximize real estate on PCB
- Mixed capacitance values and schematics
- Ideal for isolation of electronic compartments

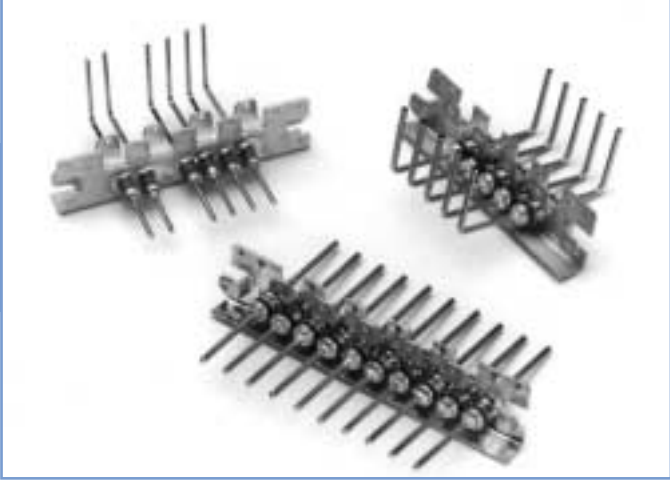

## Mechanical Specifications

### Base Plate

**Material** .....Beryllium copper

### Base Plate

**Thickness** .....010 inches (.25mm)

**Plating**.....Tin

**Lead Material**.....Copper alloy

**Lead Plating**.....Gold plate

**Lead Diameter**..... $\varnothing$  .025" (.64mm)  
for 0.100" centers (2.54mm)  
 $\varnothing$  .020 (.51mm)  
for 0.079" centers (2.00mm)

**Current Rating**.....5 Amps for .025"  $\varnothing$  (.64mm)  
3 Amps for .020"  $\varnothing$  (.51mm)

Filtered Arrays

## Ordering Information

**Example: 52-978-1-06-B-A-2**

The part number shown represents an Easy Mate® Jr. filter plate with 6 filters. Filters are C style with a capacitance value of 100pF. The plate length is .990", and the leads are bent 90° to the right side.

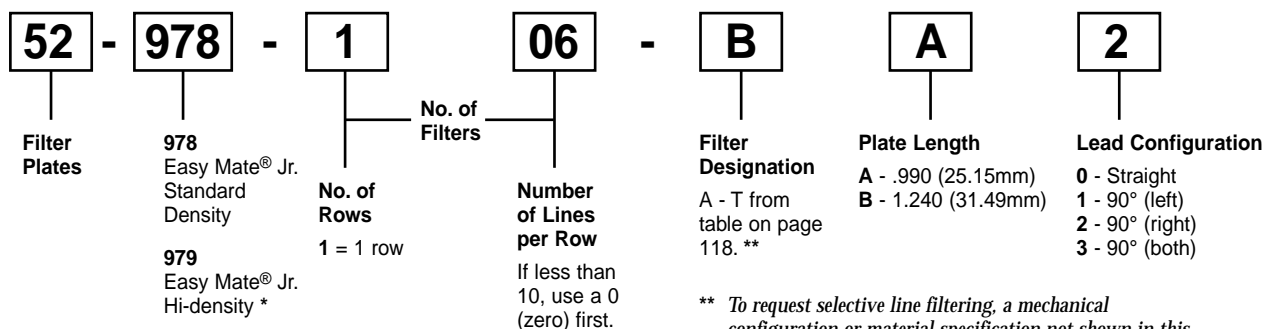

\* Maximum capacitance up to 4000pF C style filter

\*\* To request selective line filtering, a mechanical configuration or material specification not shown in this catalog, please complete and forward the design inquiry form on page 119. We will review your request and provide you with a part number.

# Easy Mate® Jr. Filter Plates

## Dimensions: inches and (mm)

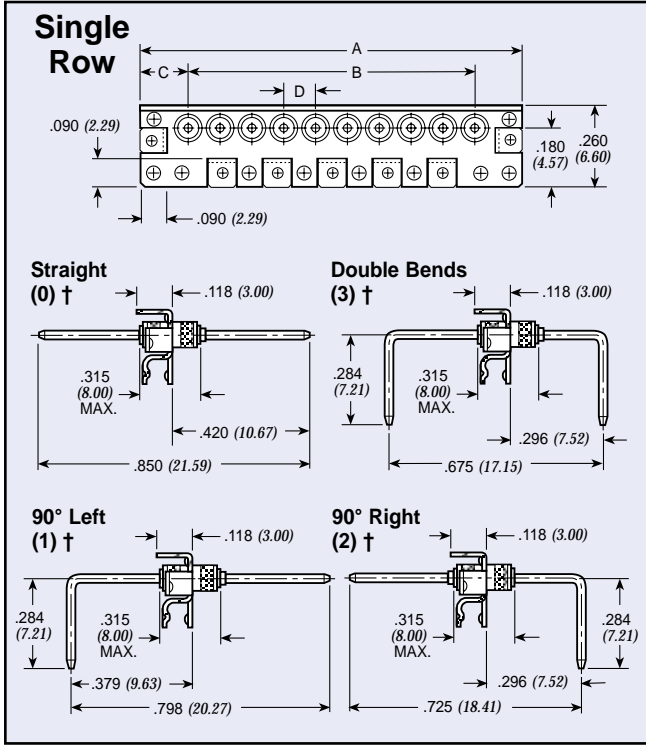

† Refers to lead configuration for part number/ordering information

## Typical Mounting Application

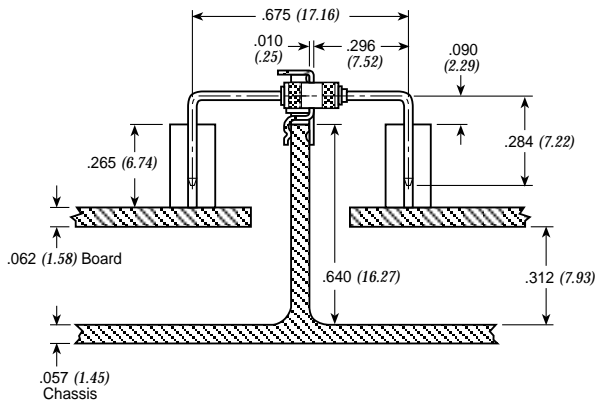

## Standard Density Centers .100" (D)

Plate length (A)	No. of filtered lines per row	52-978-XXX-XXX	
		B	C
.990 (25.15)	2	0.1 (2.54)	0.395 (10.03)
	3	0.2 (5.08)	0.395 (10.03)
	4	0.3 (7.62)	0.295 (7.49)
	5	0.4 (10.16)	0.295 (7.49)
	6	0.5 (12.70)	0.195 (4.95)
1.24 (31.49)	7	0.6 (15.24)	0.195 (4.95)
	2	0.1 (2.54)	0.570 (14.48)
	3	0.2 (5.08)	0.470 (11.94)
	4	0.3 (7.62)	0.470 (11.94)
	5	0.4 (10.16)	0.370 (9.40)
1.24 (31.49)	6	0.5 (12.70)	0.370 (9.40)
	7	0.6 (15.24)	0.270 (6.86)
	8	0.7 (17.78)	0.270 (6.86)
	9	0.8 (20.32)	0.170 (4.32)
	10	0.9 (22.86)	0.170 (4.32)

## High Density Centers 2mm (D)

Plate length (A)	No. of filtered lines per row	52-979-XXX-XXX	
		B	C
.990 (25.15)	2	0.079 (2.00)	0.417 (10.58)
	3	0.157 (4.00)	0.417 (10.58)
	4	0.236 (6.00)	0.338 (8.58)
	5	0.315 (8.00)	0.338 (8.58)
	6	0.394 (10.00)	0.259 (6.58)
1.24 (31.49)	7	0.472 (12.00)	0.259 (6.58)
	2	0.079 (2.00)	0.580 (14.75)
	3	0.157 (4.00)	0.502 (12.75)
	4	0.236 (6.00)	0.502 (12.75)
	5	0.315 (8.00)	0.423 (10.75)
1.24 (31.49)	6	0.394 (10.00)	0.423 (10.75)
	7	0.472 (12.00)	0.344 (8.75)
	8	0.551 (14.00)	0.344 (8.75)
	9	0.630 (16.00)	0.266 (6.75)
	10	0.709 (18.00)	0.266 (6.75)

## Easy Mate® Jr. Chassis Cut-out Design

Patented

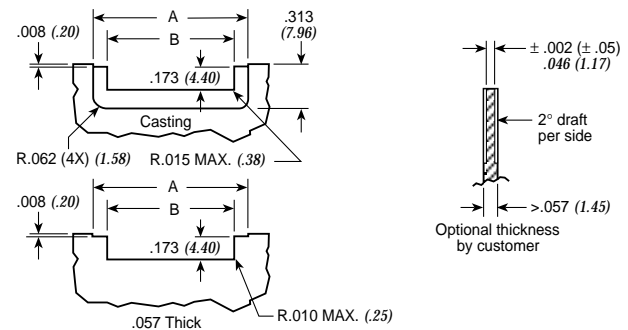
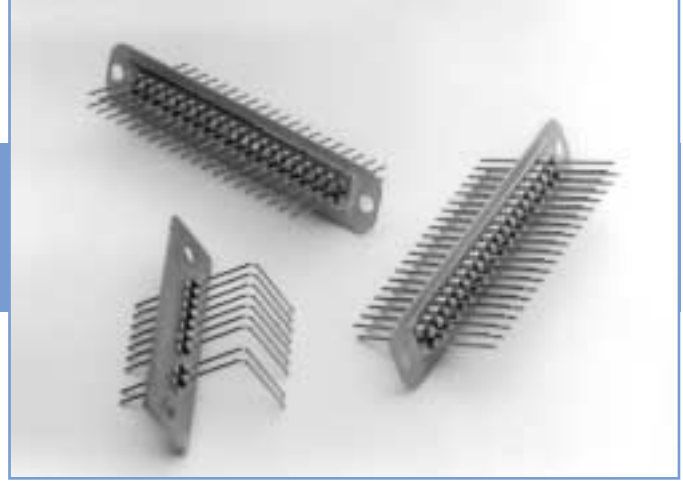

Plate Length	B	C
.990 (25.15)	1.015 (25.78)	0.834 (21.18)
1.24 (31.49)	1.265 (32.13)	1.084 (27.53)

# Bolt-in Style Filter Plates



The Bolt-in style plate provides an excellent method for electronic system interface and EMI filtering. Bolt-in filter plates are available in a variety of plate sizes and up to 74 lines per plate in hi-density (2mm) and 60 pins per plate in standard density (.100"). On the larger plate sizes, Spectrum ensures structural integrity through a unique, patent pending, coining process. The drawing on page 111 shows an electronic system utilizing Bolt-in style filter plates.

## Bolt-in Filter Plate Advantages

- Eliminates the need to assemble filters into a bulkhead
- Excellent filtering from 5 MHz to 1 GHz
- Total cost savings vs. customer installed discrete filter elements
- Ideal for isolation of electronic compartments to suppress EMI
- Outperforms surface mount filters over 50 MHz
- Improved reliability
- Mixed capacitance values and schematics
- Maximize real estate on PCB

## Ordering Information

**Example: 52-970-208-B B 2**

The part number shown represents a Bolt-in style filter plate with 2 rows, 8 filters per row. Filters are C style with a capacitance value of 100pF. The plate length is 1.560", and the leads are bent 90° to the right side.

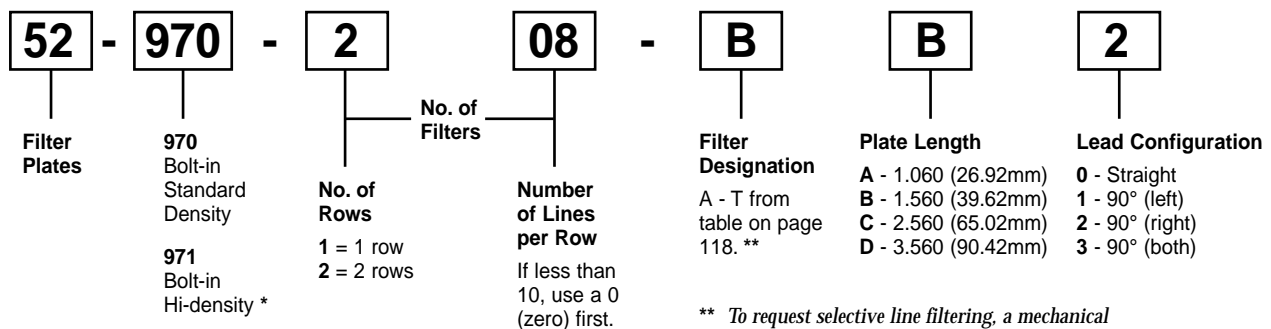

\* Maximum capacitance up to 4000pF C style filter

\*\* To request selective line filtering, a mechanical configuration or material specification not shown in this catalog, please complete and forward the design inquiry form on page 119. We will review your request and provide you with a part number.

# Bolt-in Style Filter Plates

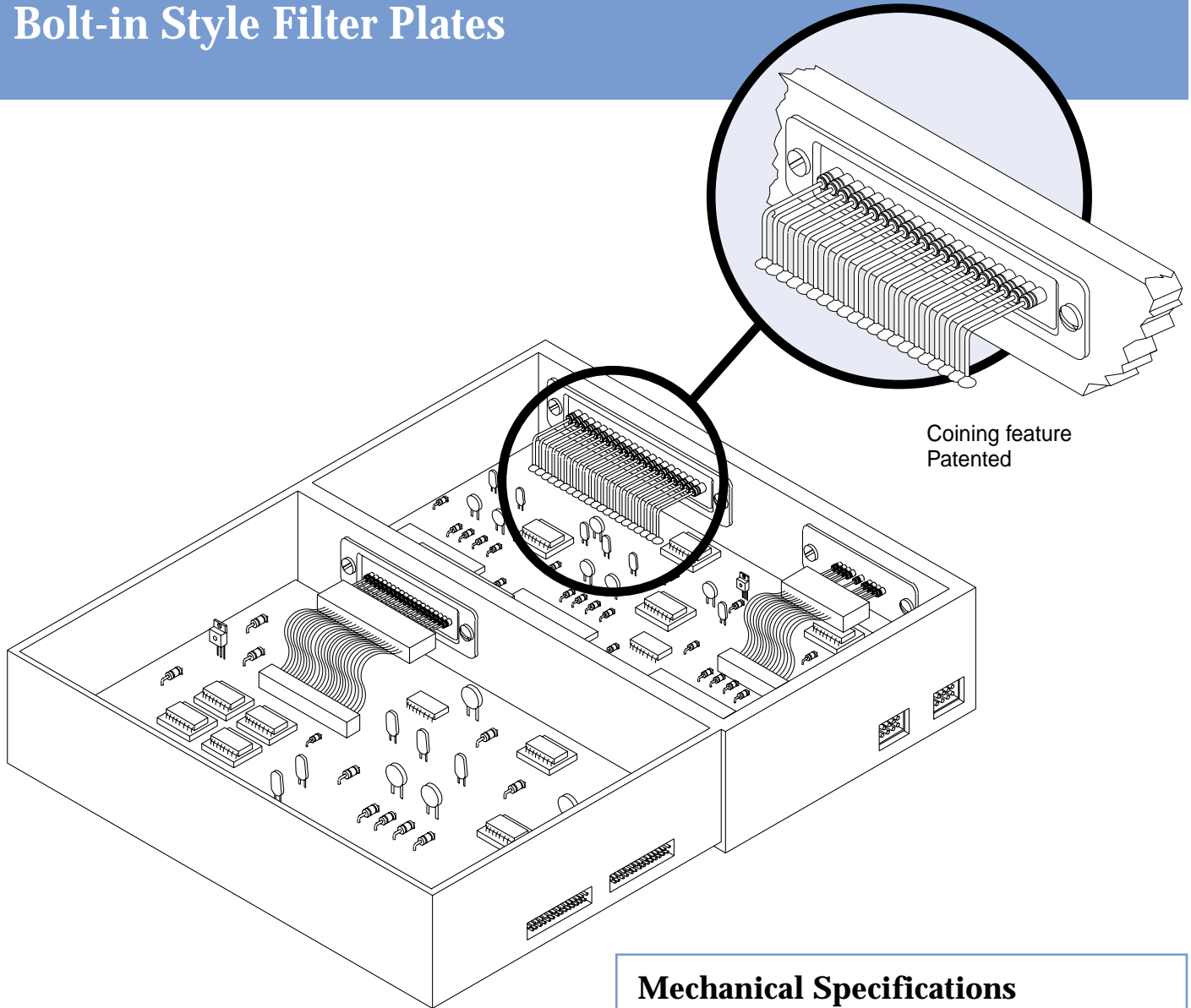

## Mechanical Specifications

<b>Base Plate</b>	
<b>Material</b> .....	Brass UNS C26000/C27000
<b>Base Plate</b>	
<b>Thickness</b> .....	.020 inches (.51mm)
<b>Plating</b> .....	Tin
<b>Lead Material</b> .....	Copper alloy
<b>Lead Plating</b> .....	Gold plate
<b>Lead Diameter</b> .....	ø .025" (.64mm) for 0.100" centers (2.54mm)
	ø .020 (.51mm) for 0.079" centers (2.00mm)
<b>Current Rating</b> .....	5 Amps for .025" (.64mm) ø 3 Amps for .020" (.51mm) ø

# Bolt-in Style Filter Plates

## Standard Density Centers .100"

**Dimensions:** inches and (mm)  
**Lead Spacing:** .100" (2.54 mm)

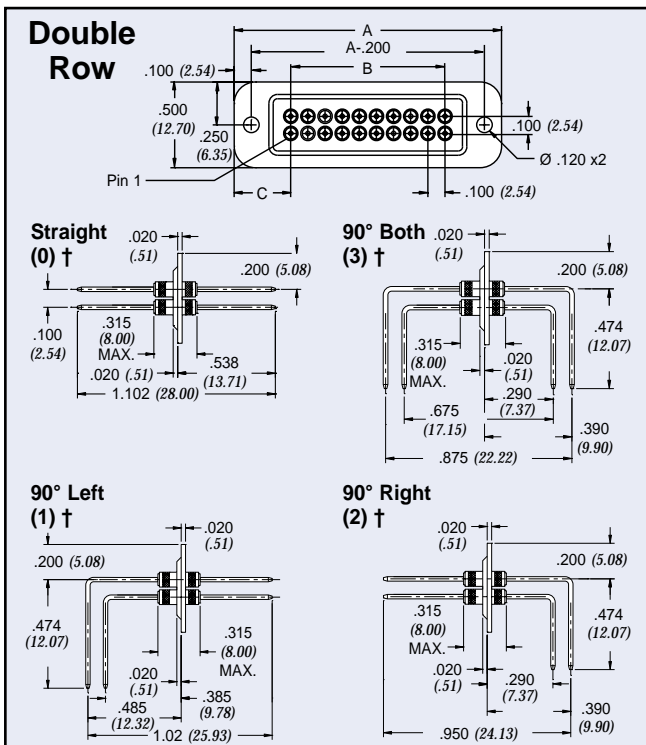
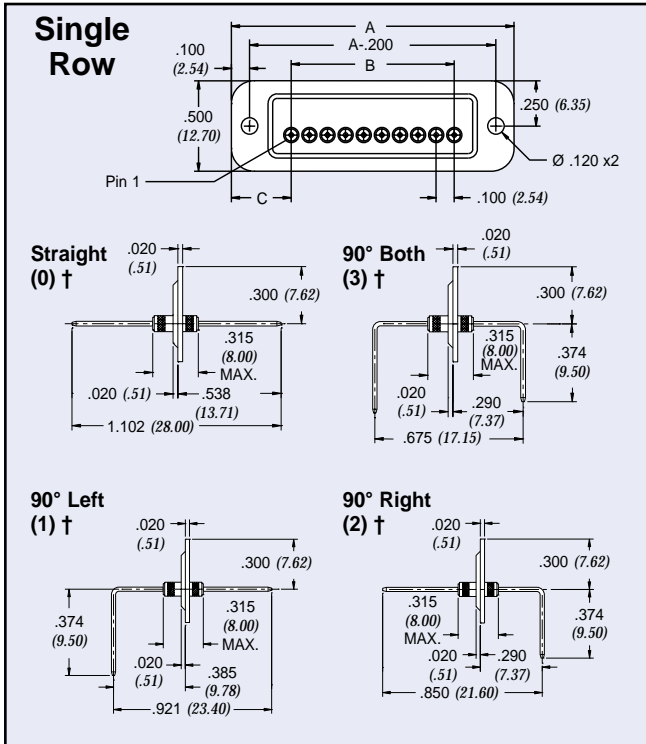

Coining feature patented

† Refers to lead configuration for part number/ordering information

Plate length (A)	No. of filtered lines per row	52-970-XXX-XXX	
		B	C
1.060 * (26.92)	1	0 (0.00)	0.53 (13.46)
	2	0.1 (2.54)	0.43 (10.92)
	3	0.2 (5.08)	0.43 (10.92)
	4	0.3 (7.62)	0.33 (8.38)
	5	0.4 (10.16)	0.33 (8.38)
1.560 * (39.62)	1	0.0 (0.00)	0.73 (18.54)
	2	0.1 (2.54)	0.73 (18.54)
	3	0.2 (5.08)	0.63 (16.00)
	4	0.3 (7.62)	0.63 (16.00)
	5	0.4 (10.16)	0.53 (13.46)
	6	0.5 (12.70)	0.53 (13.46)
	7	0.6 (15.24)	0.43 (10.92)
	8	0.7 (17.78)	0.43 (10.92)
	9	0.8 (20.32)	0.33 (8.38)
	10	0.9 (22.86)	0.33 (8.38)
2.560 (65.02)	5	0.4 (10.16)	1.03 (26.16)
	6	0.5 (12.70)	1.03 (26.16)
	7	0.6 (15.24)	0.93 (23.62)
	8	0.7 (17.78)	0.93 (23.62)
	9	0.8 (20.32)	0.83 (21.08)
	10	0.9 (22.86)	0.83 (21.08)
	11	1.0 (25.40)	0.73 (18.54)
	12	1.1 (27.94)	0.73 (18.54)
	13	1.2 (30.48)	0.63 (16.00)
	14	1.3 (33.02)	0.63 (16.00)
	15	1.4 (35.56)	0.53 (13.46)
	16	1.5 (38.10)	0.53 (13.46)
	17	1.6 (40.64)	0.43 (10.92)
	18	1.7 (43.18)	0.43 (10.92)
	19	1.8 (45.72)	0.33 (8.38)
20	1.9 (48.26)	0.33 (8.38)	
3.560 (90.42)	13	1.2 (30.48)	1.13 (27.70)
	14	1.3 (33.02)	1.13 (27.70)
	15	1.4 (35.56)	1.03 (26.16)
	16	1.5 (38.10)	1.03 (26.16)
	17	1.6 (40.64)	0.93 (23.62)
	18	1.7 (43.18)	0.93 (23.62)
	19	1.8 (45.72)	0.83 (21.08)
	20	1.9 (48.26)	0.83 (21.08)
	21	2.0 (50.80)	0.73 (18.54)
	22	2.1 (53.34)	0.73 (18.54)
	23	2.2 (55.88)	0.63 (16.00)
	24	2.3 (58.42)	0.63 (16.00)
	25	2.4 (60.96)	0.53 (13.46)
	26	2.5 (63.50)	0.53 (13.46)
	27	2.6 (66.04)	0.43 (10.92)
28	2.7 (68.58)	0.43 (10.92)	
29	2.8 (71.12)	0.33 (8.38)	
30	2.9 (73.66)	0.33 (8.38)	

\* For plate widths 1.060 and 1.560 there will be no coining.  
 For these plates, increase dimensions to the right .020".  
 Thus, any dimension on left will be reduced by .020.

Filtered Arrays

# Bolt-in Style Filter Plates

## Hi-Density Centers 2mm

**Dimensions:** inches and (mm)  
**Lead Spacing:** .079" (2.00 mm)

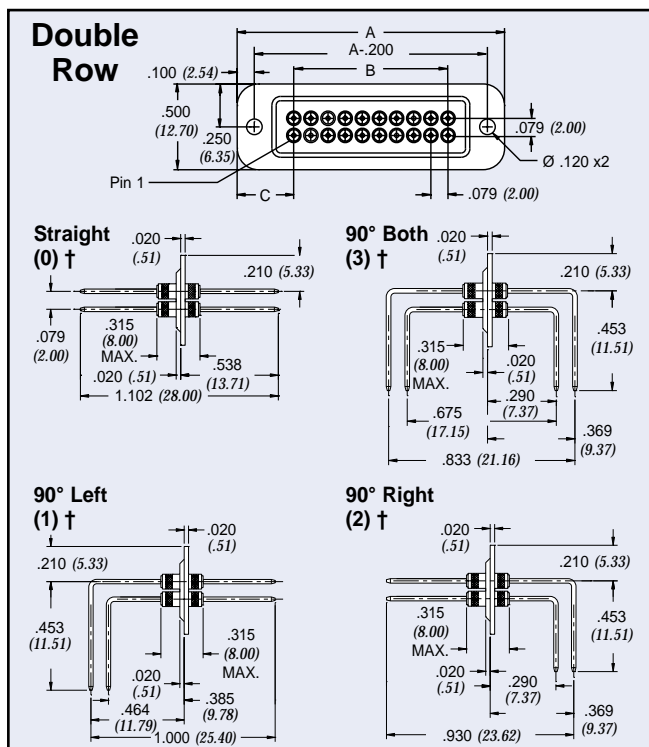
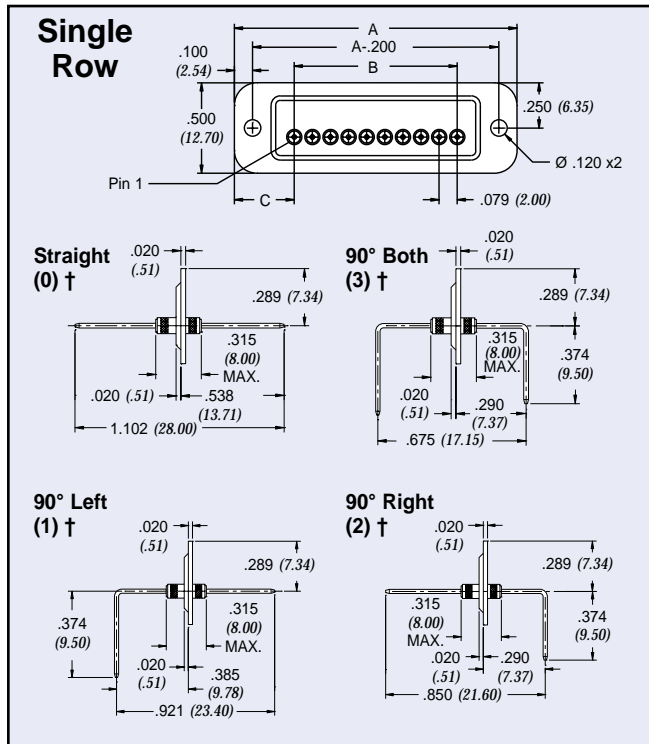

Coining feature patented

† Refers to lead configuration for part number/ordering information

Plate length (A)	No. of filtered lines per row	52-971-XXX-XXX	
		B	C
1.060 * (26.92)	2	0.079 (2.00)	0.487 (12.38)
	3	0.157 (4.00)	0.409 (10.38)
	4	0.236 (6.00)	0.409 (10.38)
	5	0.315 (8.00)	0.330 (8.38)
	6	0.394 (10.00)	0.330 (8.38)
1.560 * (39.62)	3	0.157 (4.00)	0.662 (16.81)
	4	0.236 (6.00)	0.662 (16.81)
	5	0.315 (8.00)	0.583 (14.81)
	6	0.394 (10.00)	0.583 (14.81)
	7	0.472 (12.00)	0.504 (12.81)
	8	0.551 (14.00)	0.504 (12.81)
	9	0.630 (16.00)	0.426 (10.81)
2.560 (65.02)	10	0.709 (18.00)	0.886 (22.51)
	11	0.787 (20.00)	0.886 (22.51)
	12	0.866 (22.00)	0.807 (20.51)
	13	0.945 (24.00)	0.807 (20.51)
	14	1.024 (26.00)	0.729 (18.51)
	15	1.102 (28.00)	0.729 (18.51)
	16	1.181 (30.00)	0.650 (16.51)
	17	1.260 (32.00)	0.650 (16.51)
	18	1.339 (34.00)	0.571 (14.51)
	19	1.417 (36.00)	0.571 (14.51)
	20	1.496 (38.00)	0.492 (12.51)
	21	1.575 (40.00)	0.492 (12.51)
3.560 (90.42)	22	1.654 (42.00)	0.414 (10.51)
	23	1.732 (44.00)	0.414 (10.51)
	24	1.811 (46.00)	0.335 (8.51)
	25	1.890 (48.00)	0.335 (8.51)
	20	1.496 (38.00)	0.993 (25.22)
	21	1.575 (40.00)	0.993 (25.22)
	22	1.654 (42.00)	0.914 (23.22)
	23	1.732 (44.00)	0.914 (23.22)
	24	1.811 (46.00)	0.835 (21.22)
	25	1.890 (48.00)	0.835 (21.22)
3.560 (90.42)	26	1.969 (50.00)	0.757 (19.22)
	27	2.047 (52.00)	0.757 (19.22)
	28	2.126 (54.00)	0.678 (17.22)
	29	2.205 (56.00)	0.678 (17.22)
	30	2.283 (58.00)	0.599 (15.22)
	31	2.362 (60.00)	0.599 (15.22)
	32	2.441 (62.00)	0.520 (13.22)
	33	2.520 (64.00)	0.520 (13.22)
	34	2.598 (66.00)	0.442 (11.22)
	35	2.677 (68.00)	0.442 (11.22)
	36	2.756 (70.00)	0.363 (9.22)
	37	2.835 (72.00)	0.363 (9.22)

\* For plate widths 1.060 and 1.560 there will be no coining.  
 For these plates, increase dimensions to the right .020".  
 Thus, any dimension on left will be reduced by .020.

# Shrouded Latch Filter Plates

Shrouded Latch Filter Plates are an effective method for combining an electronic interface and EMI solution in one package. The Shrouded Latch incorporates the Bolt-in concept filter plate with the latching feature of popular ribbon cable headers. This product is available in pin counts of 10 through 64 positions. The latch is available in a variety of standard heights.

The Shrouded Latch Filter Plate is ideal for securing and protecting the filter element from exposure to mechanical shock and vibration which could loosen the cable interface.

## Shrouded Latch Filter Plate Advantages

- Available in 10 to 64 positions
- Mates to most ribbon cable connectors
- Variety of latch ejector heights available
- Pins on .100" centers
- Reliable cable retention for high vibration applications
- Mixed capacitance values and schematics available
- Excellent filtering from 5 MHz to 1 GHz and beyond
- Shroud protects filter elements from potential damage

## Ordering Information

### Example: 53-038-014-BS1

The part number shown represents a shrouded latch filter plate with 14 filtered lines. Filters are C style with a capacitance value of 100pF. The plate has a short latch height and double shroud configuration.

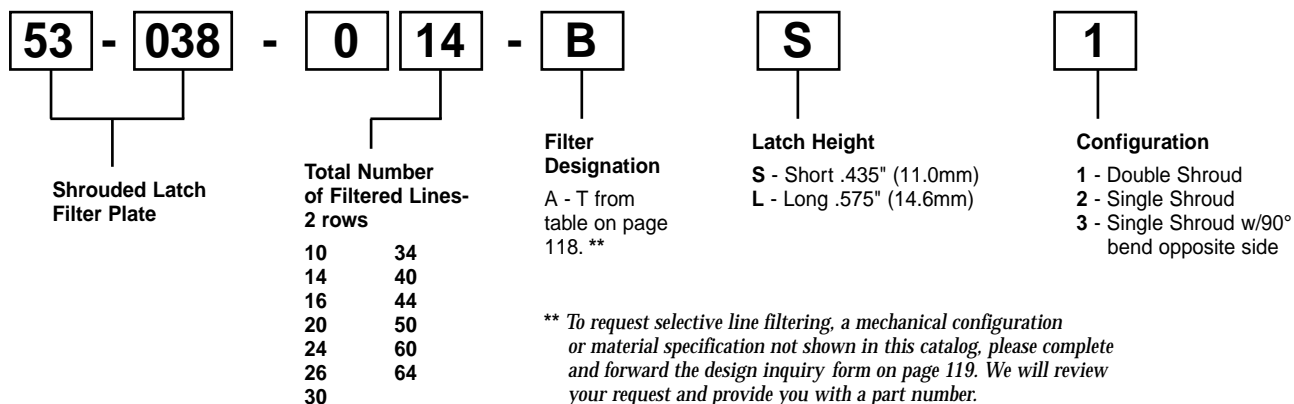

\*\* To request selective line filtering, a mechanical configuration or material specification not shown in this catalog, please complete and forward the design inquiry form on page 119. We will review your request and provide you with a part number.



## Mechanical Specifications

### Base Plate

**Material** ..... Brass UNS C26000/C27000

### Base Plate

**Thickness**..... .040" (1.0mm)

**Plating**..... Tin

**Shrouded Material** ..... Thermoplastic Polyester UL94V-0

**Lead Material**..... Copper alloy

**Lead Plating**..... Gold plate

**Lead Diameter**..... ø .025" (0.6mm)

**Current Rating** ..... 5 Amps

# Shrouded Latch Filter Plates

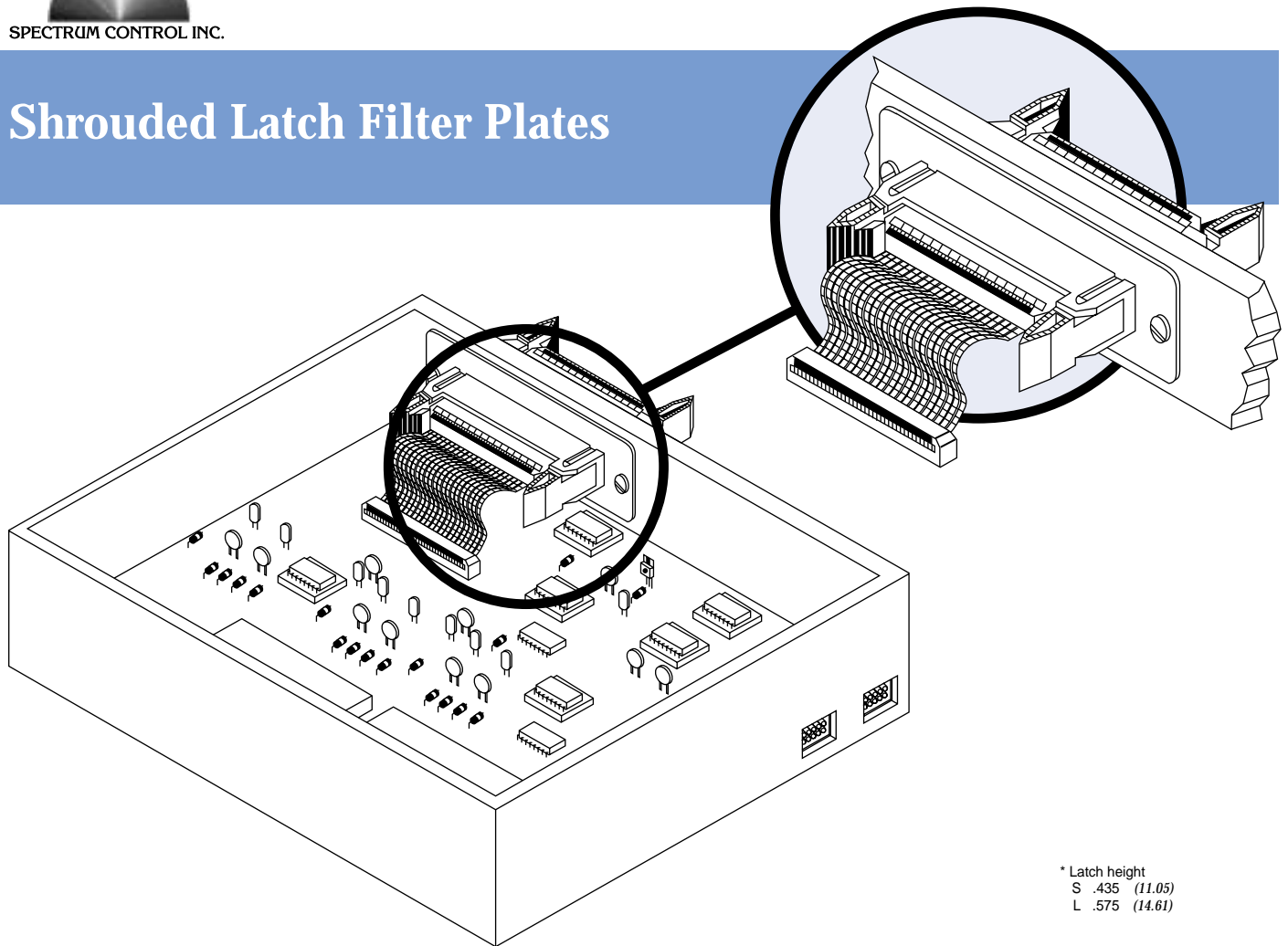

\* Latch height  
 S .435 (11.05)  
 L .575 (14.61)

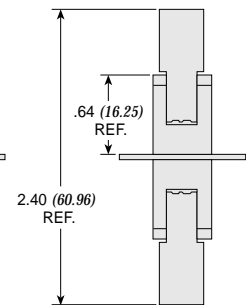
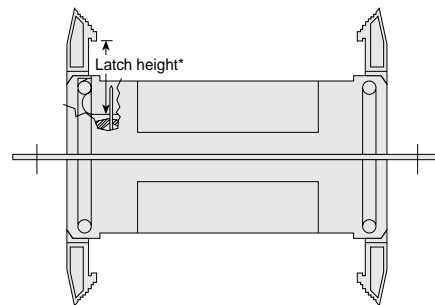
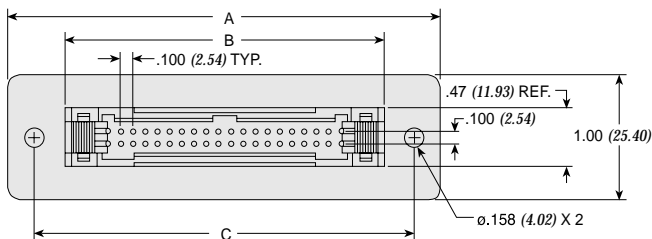

Filtered Arrays

Part Number	Number of Circuits	A		B		C	
		in	(mm)	in	(mm)	in	(mm)
53-038-010-XXX*	10	2.00	(50.8)	1.10	(27.9)	1.58	(40.1)
53-038-014-XXX	14	2.20	(55.9)	1.30	(33.0)	1.78	(45.2)
53-038-016-XXX*	16	2.30	(58.4)	1.40	(35.6)	1.88	(47.8)
53-038-020-XXX*	20	2.50	(63.5)	1.60	(40.6)	2.08	(52.8)
53-038-024-XXX	24	2.70	(68.6)	1.80	(45.7)	2.28	(57.9)
53-038-026-XXX	26	2.80	(71.1)	1.90	(48.3)	2.38	(60.5)
53-038-030-XXX	30	3.00	(76.2)	2.10	(53.3)	2.58	(65.5)
53-038-034-XXX	34	3.20	(81.3)	2.30	(58.4)	2.78	(70.6)
53-038-040-XXX*	40	3.50	(88.9)	2.60	(66.0)	3.08	(78.2)
53-038-044-XXX	44	3.70	(94.0)	2.80	(71.1)	3.28	(83.3)
53-038-050-XXX*	50	4.00	(101.6)	3.10	(78.7)	3.58	(90.9)
53-038-060-XXX	60	4.50	(114.3)	3.60	(91.4)	4.08	(103.6)
53-038-064-XXX*	64	4.70	(119.4)	3.80	(96.5)	4.28	(108.7)

\* Indicate standard sizes

Dimensions in inches (mm)

# Custom Filter Plates

## High Volume Industrial

As a long-term producer of filter plates for industrial applications, Spectrum Control understands the cost requirements of this market. In turn, we have established a program to develop and manufacture custom designed filter plates for cost sensitive industrial applications.

We have engineered a variety of capacitive only filter elements that provide excellent RF isolation from 5 MHz to 1 GHz and beyond. To determine the available capacitance values, contact Spectrum Control. Our technical staff will work with you to develop a solution that meets your system and budget needs.

## Military/High Reliability

Improving the electromagnetic compliance (EMC) of electronic systems is an area of intense focus within the defense and avionics industries. To achieve this goal, many companies are replacing discrete filter elements and surface mount filters with feed-thru filter plate assemblies for higher frequency isolation.

Spectrum Control will custom design a filter plate that meets your size, material and filtering requirements. We are capable of providing stringent testing and analysis of our filter plate assemblies to MIL-F-15733 and MIL-F-28861. To learn how Spectrum Control can satisfy your EMC application, fax or send us your requirements on the design inquiry form on page 119.

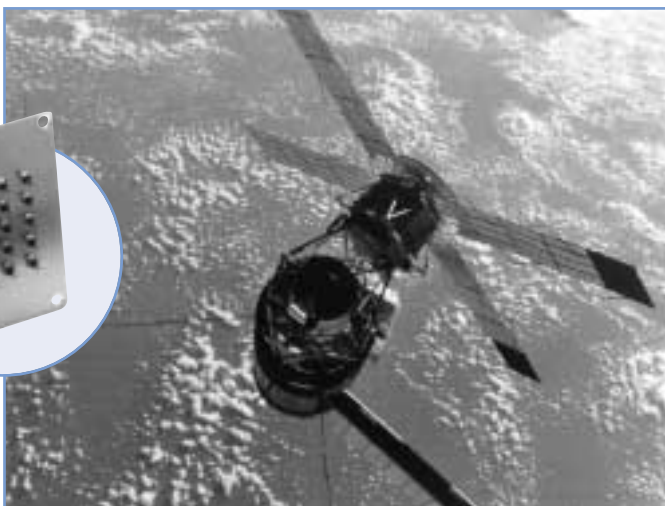

Filtered Arrays

# Custom Capabilities

In addition to our custom filter plates, Spectrum Control offers a number of value added features designed to complement your manufacturing operation. Our marketing and engineering staff will evaluate your design or manufacturing parameters and develop a filter solution which provides increased filtering performance economically.

## Spectrum Capabilities

- Custom assemblies with varying cable lengths and impedances for high clock speeds associated with digital electronics
- Integrate a filter solution with other components to ensure a completely functional device
- Perform EMC evaluations on your equipment, recommending proper placement of EMI/RFI filtering components.

## Filtered Headers

Replace the unfiltered connector on your PC board with Spectrum Control's low cost filtered header. This innovative new product allows you to meet EMC emissions and susceptibility standards with minimal or no board change.

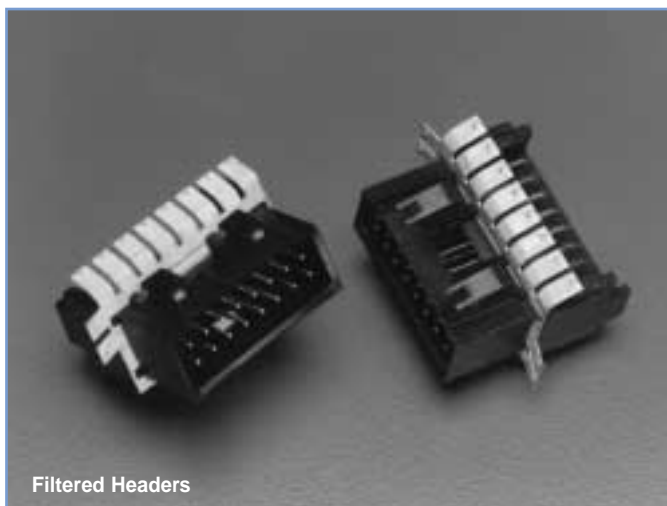

Filtered Headers

## Flat Conductor Cables

Flat conductor cables are often selected as an effective method of interconnection. Spectrum can save you time and money by installing conductor cables to your filter plates. Flat conductor cables are available in varying lengths, conductor counts, and in several termination configurations.

## Lead Stabilizer

Spectrum Control has developed a filter plate lead stabilizer bar to protect leads during installation and ensure proper alignment to PCB.

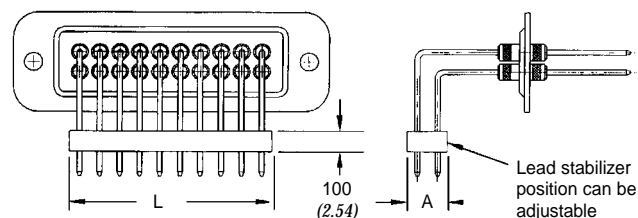
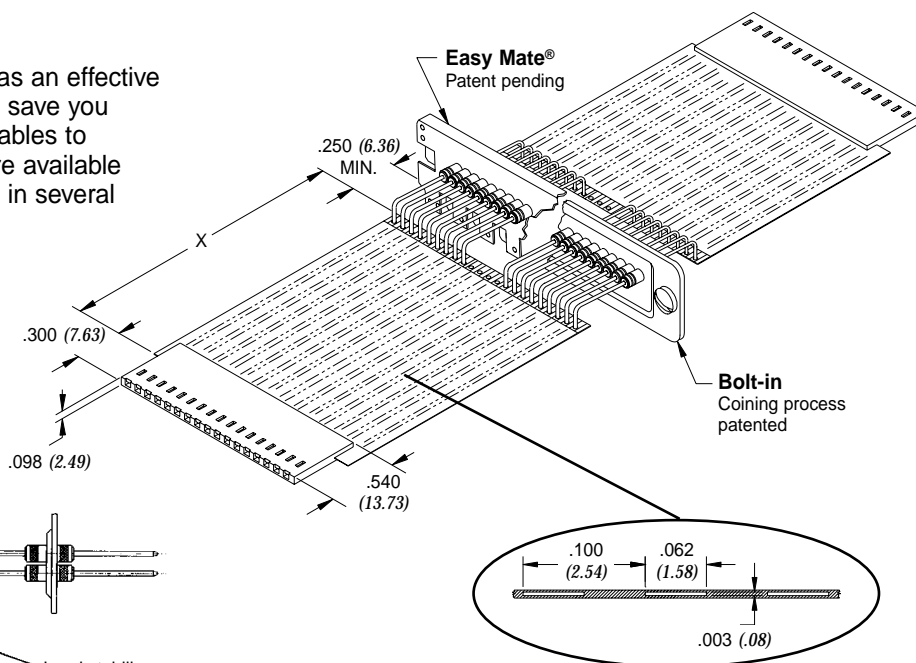

Filtered Arrays

# Filter Selection

## EMI Filter Performance

The electrical characteristics table and insertion loss graphs indicate the performance of feed-thru capacitors and Pi type filters. Utilize this information to specify the EMI filtering components included in your filter plate.

## Custom Filtering

Spectrum Control filter plates are engineered to accommodate selective line filtering. Several different types of filters may be specified in a single, easy to install filter plate, allowing you to facilitate a wide range of filtering requirements.

For selective line filtering, provide a sketch indicating the filters and positions required. The example below represents a 10 pin, 2 row plate with six 1000 pF feed-thru capacitors and four 1700 pF Pi type filters.

Part Number  
Based on front  
view of plate

10	F	F	F	R	R	6
1	F	F	F	R	R	5

## Typical Insertion Loss

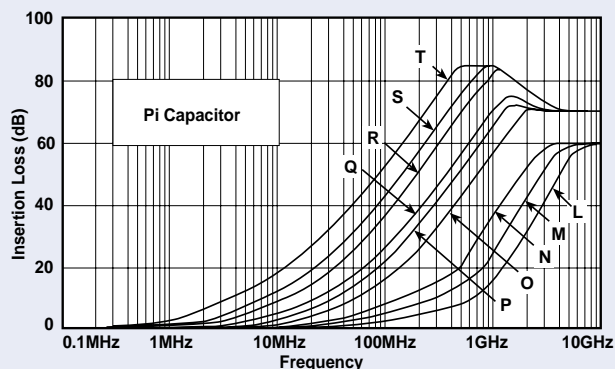
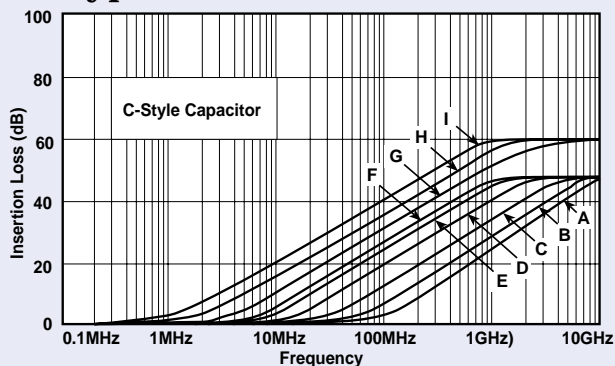

Above curves represent application of proper grounding fundamentals, for assistance consult with Spectrum Control.

Filtered Arrays

Filter Designation	Filter** Circuits	Capacitance		3 dB Max Cut-off Frequency (MHz)*	Working Voltage DC -55°C to +125°C	Minimum Insertion Loss - Decibels (dB) 50 ohm system per MIL-STD-220 (no load)							
		Value	Tolerance			5 MHz	10 MHz	20 MHz	50 MHz	100 MHz	200 MHz	500 MHz	1 GHz
A	C	68 pF	±20%	77	100V	—	—	—	—	—	3	10	16
B		100 pF	±20%	53	100V	—	—	—	—	1	6	14	19
C		135 pF	+100/-0%	23	100V	—	—	—	1	5	10	16	20
D		470 pF	±20%	11	100V	—	—	2	7	13	19	25	27
E		820 pF	±20%	6	100V	—	2	6	12	18	24	30	33
F		1000 pF	±20%	5	100V	—	3	7	14	20	26	32	35
G		1500 pF	±20%	3.5	100V	1	4	10	16	22	29	36	37
H		2500 pF	+100/-0%	1.3	100V	5	11	17	23	29	35	38	40
I		4000 pF	+100/-0%	.8	100V	9	15	21	27	34	38	42	46
J	Insulated	10 pF	Max.	635	100V	—	—	—	—	—	—	—	
K	Grounded Insert					—	—	—	—	—	—	—	
L	Pi	68 pF	±20%	65	100V	—	—	—	—	1	6	17	23
M		100 pF	±20%	46	100V	—	—	—	—	2	9	22	28
N		135 pF	+100/-0%	25	100V	—	—	—	1	6	17	26	34
O		470 pF	±20%	11	100V	—	—	—	9	18	22	36	43
P		820 pF	±20%	6	100V	—	—	4	13	23	31	45	52
Q		1000 pF	±20%	5	100V	—	2	7	16	24	36	51	59
R		1700 pF	+100/-0%	1.9	100V	1	6	14	28	35	49	64	69
S		2500 pF	+100/-0%	1.3	50V	4	9	16	28	41	54	70	70
T		5000 pF	+100/-0%	.7	100V	9	15	28	41	53	66	70	70

\* 3 dB cut-off frequency calculated at the maximum capacitance.

\*\* For Hi-Density centers (2 mm) only C style filters are available, to a maximum of 4000pF.

All High-Density capacitors are 50 volts @ 125°C.

# Custom Filter Plates

## Filter Plate Design Inquiry Form

### General Information

Customer: _____	Location: _____
Address: _____	
City: _____	State: _____ Zip: _____
Contact: _____	Title: _____
Phone: _____	Fax: _____

### Project Information

Project name: _____	Annual usage: _____	Target price: _____
Intended application: _____	Quote quantity: _____	
Function of circuit filter is used in: _____	Target cost: _____	

### Functional Detail NOTE: Bold lettering represents standard, readily available material (Circle the appropriate parameters needed)

<u>Lead Diameter</u>				<u>Total Lead Length</u>			<u>Lead Material</u>		<u>Lead Plating</u>			
0.020"	<b>0.025"</b>	0.032"	0.040"	0.700"	1.00"	<b>1.102"</b>	<b>Phosphor Bronze</b>	Copper	<b>Gold</b>	Tin	Silver	
<b>Base Plate Material</b>												
<b>Brass UNS C26000/C27000</b>			Cold Rolled Steel (CRS) UNS G10080/G10180			Aluminum UNS A93003/A96061		Beryllium Copper*				
* For Beryllium Copper, ask about our new "Easy Mate®" Plate												
<u>Plate Thickness (± 0.002")</u>						<u>Plating of Base Plate</u>						
<b>(0.010" for Easy Mate® Jr.)</b>		<b>(0.020" for Bolt-in)</b>		0.026"	0.033"	0.041"	<b>Tin</b>	Silver	90/10 Solder	Nickel		
<b>(0.012" for Easy Mate®)</b>												
<u>Center-to-Center Spacing</u>						Standard (inch):			0.079	<b>0.100</b>		
(Not all capacitances available on all centers)						Metric (mm):			2	<b>2.54</b>		

### Detailed Sketch and Comments Area

Include Mounting Detail

Filtered Arrays

# Barrier Strip Filtered Terminal Blocks

The barrier strip filtered terminal block is designed provide excellent EMI/RFI filtering of AC and DC power lines and control lines. This terminal block is available in various sizes, with terminal for soldering or spade lugs. Application examples include filtering power supplies in telecommunications equipment, metering, industrial controls, instrumentation and EDP equipment.

## Features

- UL recognized and CSA approved for DC voltages
- E133076, UL 1059
- LR92537, CSA STD 22.2 N°158-1987 and ECN584B
- Filter element provides high insertion loss for EMI/RFI filtering of AC and DC power and control lines
- Rugged construction provides protection to filtering element; especially useful for repeated changes in wiring or field connections
- 2 to 6 terminals available (combine if larger number of terminals needed)
- Cost-effective solution for industrial interconnection EMI filtering problems
- Termination options available: straight lead, male or female disconnects, pigtail (12 AWG = 0.081" (2.05mm); 22 AWG = 0.025" (0.64mm))

## Ordering Information

Example: **52-160-006-A AOO**

The part number shown represents a barrier strip terminal block with six terminals and rated for 20 Amps. Male disconnects (.250") are the method of termination.

<b>52</b>	-	<b>160</b>	-	<b>006</b>	-	<b>A</b>	-	<b>AOO</b>
		<b>Barrier Strip Terminal Block</b>			<b>Number of Terminals</b>			<b>Current Rating</b>
		160 - Front panel mount			002 - 2 terminals through			A - 20 Amps
		188 - Rear panel mount			006 - 6 terminals			

For instructions on soldering to filter terminals, please refer to page 105 in filter plate section.

For product with AC rating, consult factory for 52-257-Series product and request data sheet. Product UL/CSA recognized.



## Specifications

### ELECTRICAL

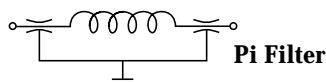

- Operating temperature:** -55° C to 105° C
- Working voltage:** 100VDC
- Capacitance:** 2,500 pF to 5,200 pF
- Dielectric withstanding voltage:** 1700VDC
- Current rating:** 20A
- D.C. resistance:** .01 ohms max.

Typical Insertion Loss — dB: In 50 Ohm Circuit	
30 MHz.....22	300 MHz.....70
50 MHz.....32	500 MHz.....75
100 MHz.....48	1000 MHz.....75

### MECHANICAL

- Center spacing:** .438" (11.1 mm)
- Wire size:** AWG #12 max for 20A
- Screw size:** 20A - #6-32, zinc-plated phillslot screws
- Molded material:** Black, UL rated 94VO thermoplastic
- Tightening torque:** 9 in.-lbs. max.
- Terminal:** Brass, tin-plated

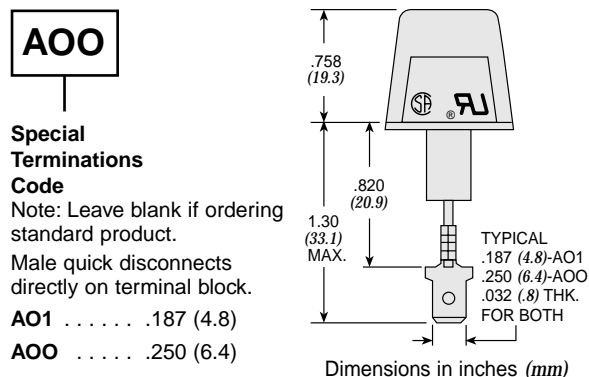

For custom designs see page 124 and consult with factory.

# Barrier Strip Filtered Terminal Blocks

## Front panel mount

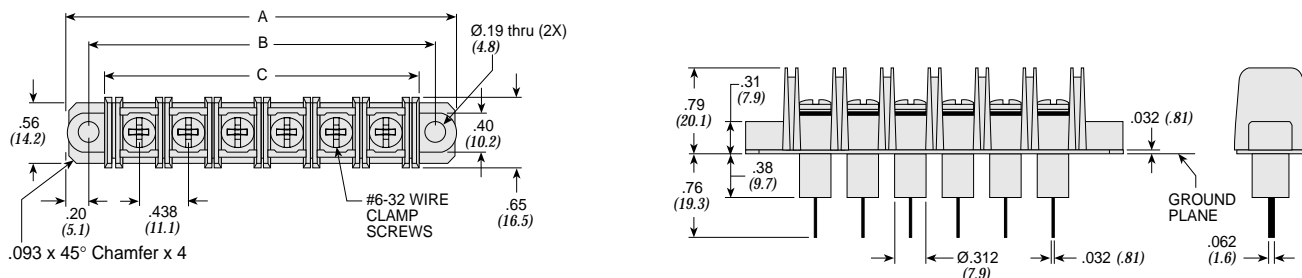

## 20 Amps

Dimensions in inches (mm)

Part Number	Number of Circuits	in. A (mm)	in. B (mm)	in. C (mm)
€ 52-160-002-A	2	1.71 (43.4)	1.31 (33.3)	1.02 (25.9)
52-160-003-A	3	2.15 (54.6)	1.75 (44.5)	1.46 (37.1)
52-160-004-A	4	2.59 (65.8)	2.19 (55.6)	1.90 (48.3)
52-160-005-A	5	3.02 (76.7)	2.62 (66.5)	2.32 (58.9)
52-160-006-A	6	3.46 (87.9)	3.06 (77.7)	2.77 (70.4)

€ Also available through Spectrum Control's authorized European distributors/agents.

## Rear panel mount

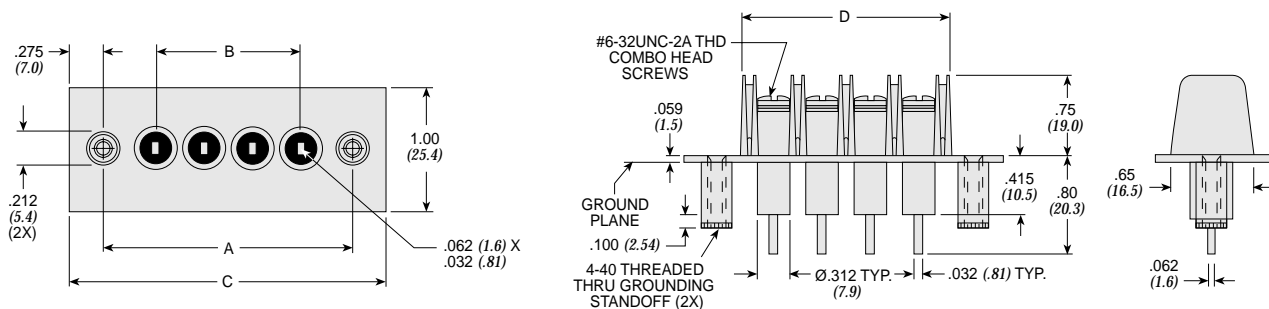

## 20 Amps

Dimensions in inches (mm)

Part Number	Number of Circuits	in. A (mm)	in. B (mm)	in. C (mm)	in. D (mm)
52-188-002-A	2	1.31 (33.3)	.438 (11.1)	1.86 (47.3)	1.02 (25.9)
52-188-003-A	3	1.75 (44.4)	.875 (22.2)	2.30 (58.4)	1.46 (37.1)
52-188-004-A	4	2.19 (55.6)	1.313 (33.3)	2.74 (69.5)	1.90 (48.3)
52-188-005-A	5	2.62 (66.6)	1.750 (44.4)	3.17 (80.6)	2.32 (58.9)
52-188-006-A	6	3.06 (77.7)	2.188 (55.6)	3.61 (91.7)	2.77 (70.4)

# PCB Mount Filtered Terminal Blocks

The PCB mount filtered terminal block is designed to provide excellent EMI/RFI filtering of low voltage DC power lines and control lines. These new terminal blocks use a unique screw clamp system with a wire protector which provides for quick and easy installation. Spectrum's PCB Mount terminal blocks can be used for a variety of power supply filtering applications in telecommunications equipment, metering, industrial controls, instrumentation and EDP equipment.

## Features

- Filter element provides high insertion loss for EMI/RFI filtering of DC power and control lines
- Rugged construction provides protection to filtering element; especially useful for repeated changes in wiring or field connections
- 2 to 12 terminals available (combine if larger number of terminals needed)
- Quick and easy PCB installation and maintenance
- Cost-effective solution for industrial interconnection EMI filtering problems
- Selectively loaded filter pins to economically meet exact filtering requirements
- Available with European (5 mm) or US (.200") pin spacing

## Ordering Information

Example: **52-227-006-L**

The part number shown represents a low profile PCB mount terminal block for thru-hole grounding with six terminals (US spacing).

52	-	227	-	006	-	L
Terminal Block type		Number of terminals		Low profile sizing		
227 U.S. pin spacing 228 Metric pin spacing		002 - 2 terminals thru 012 - 12 terminals		See page 123		



## Specifications

### ELECTRICAL

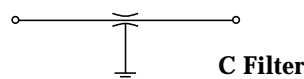

**Operating temperature:** -40° C to 80° C  
**Working voltage:** 100VDC  
**Capacitance:** 2500 pF\* +80% / -20%  
**Dielectric withstanding voltage:** 707VDC  
**Current rating:** 12 Amps max.  
**D.C. resistance:** .01 ohms max.

Typical Insertion Loss — dB: In 50 Ohm Circuit			
10 MHz.....	10.4	500 MHz.....	43.9
50 MHz.....	23.9	1000 MHz.....	49.9
100 MHz.....	29.9		

### MECHANICAL

**Center spacing:** US .200: (5.08 mm)  
EURO .197" (5 mm)  
**Wire size:** AWG 12 through 26  
**Screw material:** steel, zinc chromate plate  
**Recommended PCB hole diameter:** .05" (1.30 mm) contact hole  
**Molded material:** UL rated 94VO polyamide  
**Tightening torque:** 2.5 in.-lbs. max.  
**Terminal:** Brass, tin-plated

\* For filter elements with additional capacitance values, consult factory.

# PCB Mount Filtered Terminal Blocks

## US Pin Spacing

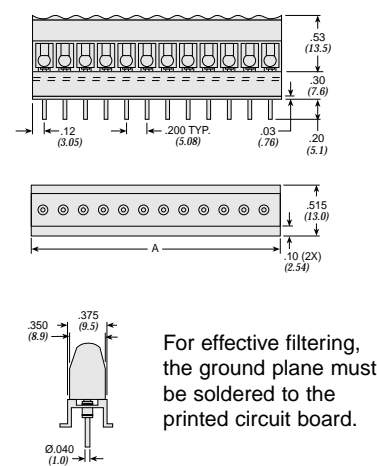
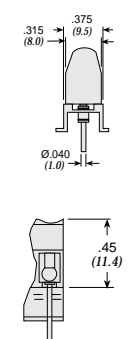
Part Number	Number of Circuits	in.	A (mm)		
52-227-002	2	.44	(11.2)	 <p>For effective filtering, the ground plane must be soldered to the printed circuit board.</p>	<p><b>Low Profile</b></p> <p>To order add -L- after part number.</p> 
52-227-003	3	.64	(16.3)		
52-227-004	4	.84	(21.4)		
52-227-005	5	1.04	(26.5)		
52-227-006	6	1.24	(31.5)		
52-227-007	7	1.44	(36.6)		
52-227-008	8	1.64	(41.7)		
52-227-009	9	1.84	(46.8)		
52-227-010	10	2.04	(51.9)		
52-227-011	11	2.24	(57.0)		
52-227-012	12	2.44	(62.0)		

Dimensions in inches (mm)

## Metric Pin Spacing

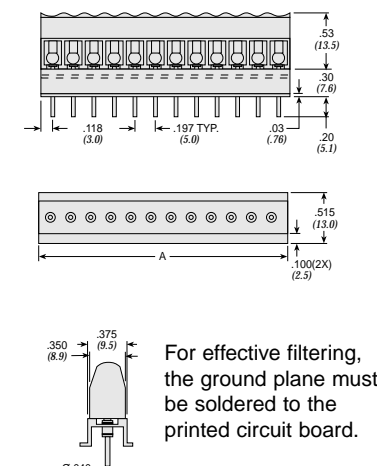
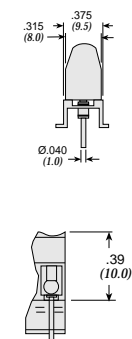
Part Number	Number of Circuits	in.	A (mm)		
52-228-002	2	.43	(10.9)	 <p>For effective filtering, the ground plane must be soldered to the printed circuit board.</p>	<p><b>Low Profile</b></p> <p>To order add -L- after part number.</p> 
52-228-003	3	.63	(16.0)		
52-228-004	4	.83	(21.1)		
52-228-005	5	1.02	(25.9)		
52-228-006	6	1.22	(31.0)		
52-228-007	7	1.42	(36.1)		
52-228-008	8	1.61	(40.9)		
52-228-009	9	1.81	(46.0)		
52-228-010	10	2.00	(50.8)		
52-228-011	11	2.20	(55.9)		
52-228-012	12	2.40	(61.0)		

Dimensions in inches (mm)

# Custom Filtered Terminal Blocks

## Terminal Block Design Inquiry Form



Spectrum Control can incorporate EMI filters into a variety of terminal block designs. We offer product variations from several terminal block manufacturers. In addition to developing a filtering solution, we will add custom wiring and terminations to meet your requirements. Spectrum Control offers:

- Unique package integration for customer specific needs
- Wide range of designs from numerous terminal block manufacturers
- Custom assemblies with varying cable lengths and terminations

### Terminal Block Design Inquiry Form

#### General Information

Customer: _____	Location: _____
Address: _____	
City: _____	State: _____ Zip: _____
Contact: _____	Title: _____
Phone: _____	Fax: _____

#### Project Information

Project name: _____	Annual usage: _____	Target price: _____
Intended application: _____	Quote quantity: _____	
Function of circuit filter is used in: _____	Target cost: _____	

#### Detailed Sketch and Comments Area

Filtered Arrays

# EMI Filtered Connectors

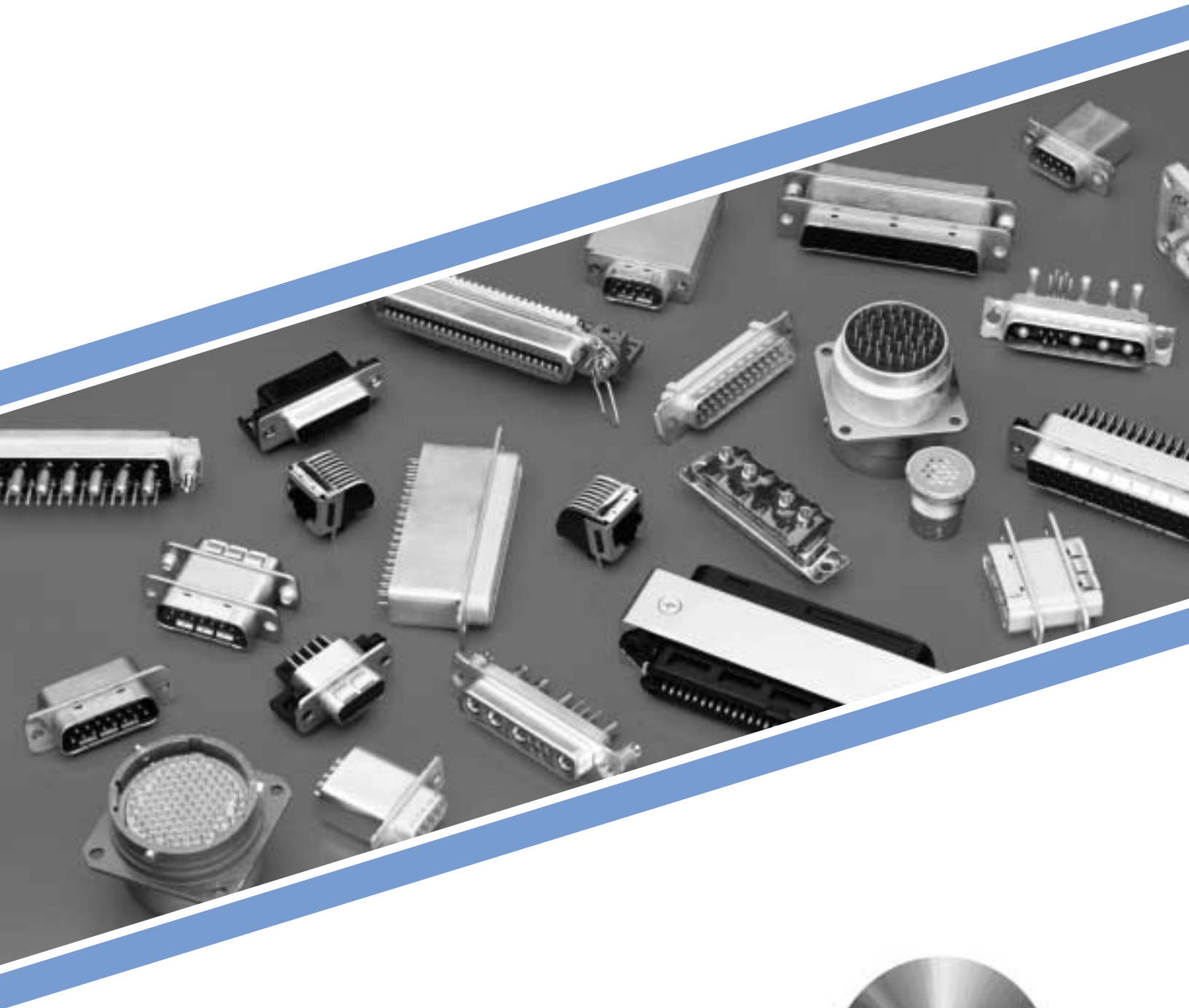

**ISO 9001**  
CERTIFIED



**SPECTRUM CONTROL INC.**  
A Control Products and Systems Company  
**Signal and Power Integrity Group**

# Filtered Connector Product Positioning Guide

## Series F Ferrite Filtered Connectors

- Filtering of high frequency interference
- Short, space saving .318" footprint
- Replaces individual ferrite leads, saving cost and space
- Effective in meeting FCC, VDE, EN55022 and Japan's VCCI requirements

The Series F ferrite filtered connector is designed as a low cost EMI solution for high frequency interference. The space saving .318" footprint makes this product interchangeable with standard D-subminiature connectors.

*Series F Connectors . . . . . 129-133*

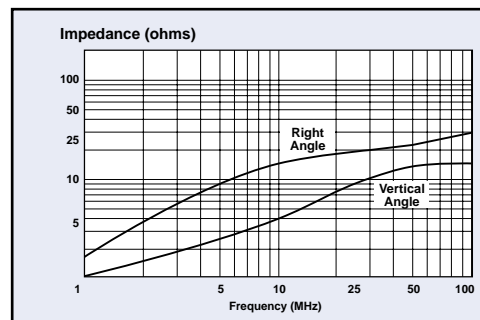

## Series 100 Chip-Cap Filtered Connectors

- Lowest cost capacitive filtered connectors
- Available in 9, 15, 25 and 37 shell sizes
- 0.318", 0.405" and 0.590" footprints available
- Selective line filtering is available

The Series 100 connectors provide an excellent combination of low cost and good performance. Styles are available as "drop-in" replacements for unfiltered connectors and as adapters for non-standard applications.

*Series 100 Connectors . . . . . 134-137*

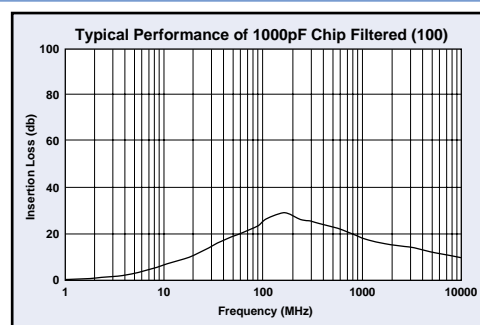

## Series 500 Low Profile Feed-thru Connectors

- Low Cost, High Performance connectors
- Available in 9, 15 and 25 shell sizes
- Compact design with a 0.318" footprint
- Solid ground plane design provides EMI shielding

The Series 500 filtered D-subminiature connectors feature a compact design for 90° PCB connectors and straight PCB connectors utilizing tubular capacitors. These filtered D-Subs are "drop-in" replacements for standard unfiltered connectors.

*Series 500 Connectors . . . . . 138-141*

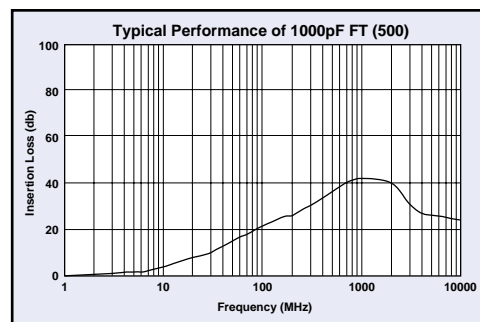

## Series 700 High Performance Filtered Connectors

- Available in 9, 15, 25, 37 and 50 shell sizes
- One piece die cast housing design
- Available in both feed-thru capacitive and PI configurations
- Selective line filtering is available
- Tubular capacitor filtering provides effective performance through 10 GHz

These connectors are a highly effective method of filtering at the I/O interface. The ability to selectively filter lines allows signals of various rates to pass without degrading signal integrity. Series 700 connectors feature a .590" footprint on right angle connectors. Styles are available with pin or socket contacts or as pin/socket adapters.

*Series 700 Connectors  
Filter Selection  
and Specifications . . . . . 146-147  
Shell Size 9 Connectors . . . . . 148-151  
Shell Size 15 Connectors . . . . . 152-155  
Shell Size 25 Connectors . . . . . 156-159  
Shell Size 37 Connectors . . . . . 160-163  
Shell Size 50 Connectors . . . . . 164-167*

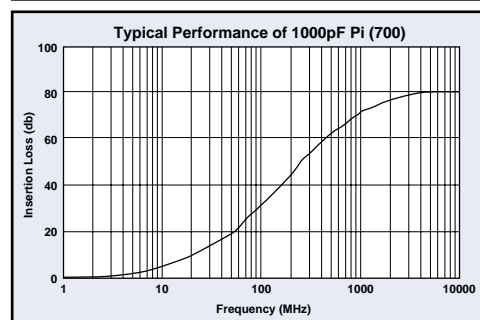
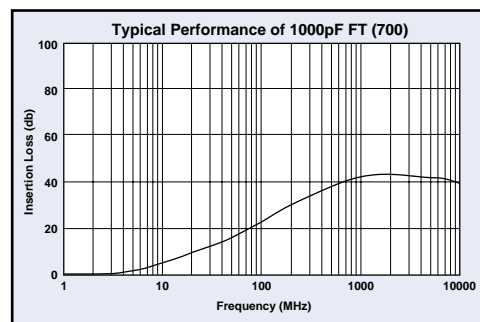

# Filtered Connector Selection Guide

## Other Key

Pages	Pages
Part Numbers & Options	168-169
Adapter Test Kit	190
High Voltage Adapters	191
Waved Metal Gaskets	192
Hooded Strain Reliefs	193
Custom Engineered Solutions	194
Performance Testing	195
Board & Panel Cutouts	196-197

## Series 600 Hi-Density Filtered Connectors

- Available in 15, 26, 44, 62 and 78 shell sizes
- Compact design using one piece die cast housing
- Available in feed-thru capacitive configurations
- Selective line filtering is available

This line of connectors incorporates the high performance and reliable filtering of Spectrum's standard D-sub's in a Hi-Density format. These connectors are also available in a pin/socket adapter.

<i>Series 600 Hi-Density Connector</i>	142-143
<i>Series 600 Hi-Density Telecommunications Adapter</i>	144-145

## Filtered Combo D-Subminiature Connectors

- Excellent filtering of signal, power and coaxial contacts with high performing feed-thru capacitors
- Ground plane design provides superior EMI shielding
- Available in a wide variety of mixed versions

Spectrum's line of filtered combo D-sub's provide high insertion loss with tubular capacitive filtering. These connectors are available with 20 Amp power contacts, 40 Amp power contacts, 50 ohm coaxial contacts or 75 ohm coaxial contacts. High strength epoxy potting protects ceramic elements.

<i>Filtered Combo D-Subminiature Connectors</i>	170-177
---	---------

## Series E (ESD/EFT) Transient Protected Connectors

- Fail safe design guards equipment in case of severe surge
- Connects directly between the serial or parallel port of your hardware and cable
- Available in 9, 15, 25, and 37 line protection

Surge suppressors provide protection against data loss and damage due to transient over-voltages from a variety of sources including lighting, factory equipment, motors and AC power lines. Protects printers, personal computers, LANS, WANS, RS-232 and RS-422/485 equipment.

<i>Series E Connectors</i>	178-181
----------------------------	---------

## Datacom Connectors

- Modular jack connectors available filtered with ferrite or capacitive film
- Modular jack connectors available in single or multiport styles
- Miniature ribbon connectors and adapters filtered with chip capacitors
- Miniature ribbon connectors and adapters available in 50 line configurations

Filtered datacom connectors are available for a wide variety of applications including original telephone manufacturing, operating telephone companies, cable reclamation, cable manufacturing and bay connectorization, LANs, WANs, network cards, broadband transmissions, workstations, peripherals, fax/modems, copy machines and multiplexing.

<i>Filtered Miniature Ribbon Connectors and Adapters</i>	182-185
<i>Filtered Modular Jack Connectors</i>	186-188
<i>Filtered Mini-DIN Connectors</i>	189

## Custom Filtered Connectors

- Available in C, Pi, LC and T configurations
- Able to filter most connector interface types including circular, rack and panel, ARINC, etc.
- Value added options such as wire harnessing, flex circuits and hermeticity are available
- Selective line filtering available
- Use either tubular capacitors or planar arrays

This series of filtered connectors includes custom products ranging from MIL-C-38999, ARINC military connectors to filtered industrial connectors. These connectors are available with capacitor values up to 500,000 pF per line making it ideal for most applications. Common markets for custom filtered connectors are military, industrial and medical equipment.

<i>Compact Shell Filtered Connectors</i>	199
<i>MIL-C-38999</i>	200-205
<i>Extended Shell Filtered Connectors</i>	206
<i>MIL-C-38999</i>	207-215
<i>MIL-C-83723</i>	216-219
<i>MIL-C-26482</i>	220-223
<i>Custom Filtered Connectors</i>	224-225
<i>Quality Acceptance Test Specifications</i>	226

# Advantages of Spectrum Filtered Connectors

Spectrum offers the industry's most complete line of filtered D-subminiature connectors.

## Features

- All shell sizes (9, 15, 25, 37 and 50)
- Many termination types (PC mount, wire wrap, solder cup and 90° PCB)
- In house ceramic tube design for high performance filtering
- Filtering options:
  - Pi Filter Configuration (*Provides 45-60 dB per decade slope to insertion loss curve*)
  - Capacitive only C Filters (*Provides cost-effective EMI attenuation*)
  - Ferrite Filtered Series F Connectors (*Provides filtering in situations that do not tolerate capacitive loading of circuit*)
  - Series 500 Connectors (*Short .318" PCB footprint*)
  - Chip-Cap Series 100 Connectors (*Short .318" PCB footprint*)
- Construction (Series 600 & 700)
  - One piece zinc diecast shell, nickel plated
  - Complete 360° grounding with ground plate
  - Patented coaxial springs ensure ground continuity

Factors to be considered when evaluating EMI filtering through filtered connector or on-board filter:

- EMI effectiveness
- Cost of components
- Hidden costs of extra components
- Design of board
- Reliability

## Advantages of a Filtered Connector

- **Low ground impedance** – Full ground plate and metallic shell provide minimal impedance and superior performance compared to on-board filter with high impedance
- **Eliminate re-radiation** – Filtered connector at interface leaves no path for bypassing the filter
- **Ground plane shielding** – Spectrum Control filtered connector ground planes shield the box even at the connector port
- **Efficient space utilization** – Filters located in connector provides additional space on PCB board
- **Consistent performance** – Filtered connectors provide more consistent pin to pin performance
- **Fewer components** – Filtered connectors reduce component count creating cost savings
- **Reliability** – Spectrum Control tests 100% of filters, on-board filters are usually spot tested



D-Subminiature Connectors

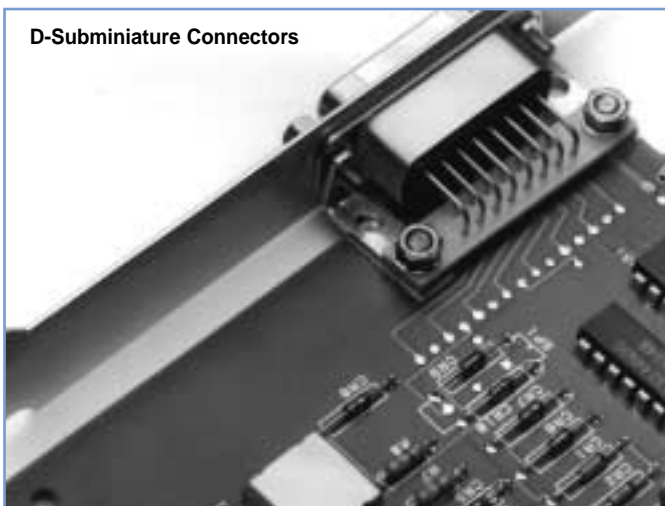

On-Board Filters

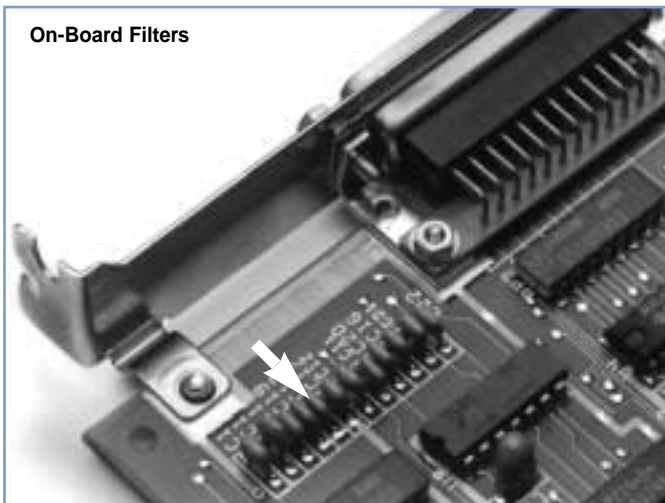

# Series F Ferrite Filtered Connectors

The Series F filtered D-subminiature connectors incorporate a solid slab of ferrite material as the filtering element. This rugged one piece design provides a compact connector that is a drop-in replacement for standard connectors. The ferrite material has been chosen for optimum filtering performance in the 10 to 300 MHz. range.

## Series F Applications

- Personal computers, microcomputer-applied products and peripheral/terminal equipment
- Eliminates common-mode noise along data lines in data communication terminals and digital equipment

## Features

- Low cost, high performance ferrite filter
- No distortion of wave forms
- Replaces individual ferrite bead filters, saving cost and space
- Provides both pin to ground and pin to pin filtering
- Effective in helping meet requirements of FCC, VDE, EN55022 and Japan's VCCI
- Short, space saving .318" footprint
- Interchangeable with standard D-subminiature connectors
- Can be installed directly over PCB trace pattern with no shorting
- 4-40 UNC locking insert eliminates loose hardware
- Metal shielding front shell
- Gold plated contacts
- Stacked ferrite connectors also available — consult factory for more information

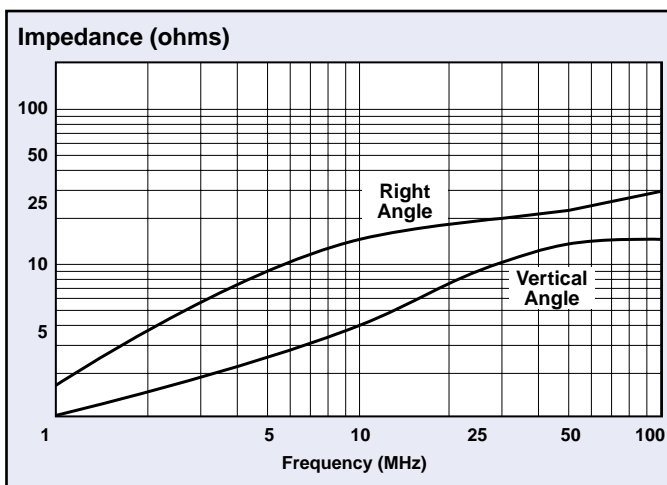

## Mechanical Specifications

- Front Shell* . . . . . Steel (Tin Plated)  
*Housing* . . . . . UL 94V-0 Rated thermoplastic, black  
*Contacts* . . . . . Phosphor Bronze (sockets) or Brass (pins)  
*Contact Plating* . . . . . Gold Flash (<10µ in.) over Nickel  
*Operating Temperature* . . . . . -40°C to +105°C

## Electrical Specifications

Frequency (MHz)	Impedance (Ohms)	
	Right Angle	Vertical
1	2	1
10	15	6
30	20	10
50	23	12
100	27	15

- Frequency Range* . . . . . 10 – 300 MHz  
*Current Rating* . . . . . 5 Amps  
*Dielectric Withstand Voltage* . . 1000 VAC for one minute  
*Insulation Resistance* . . . . . 1000 megohms Min. @ 500VDC

# Series F Ferrite Filtered Connectors

## Pin Contact – Right Angle Mount

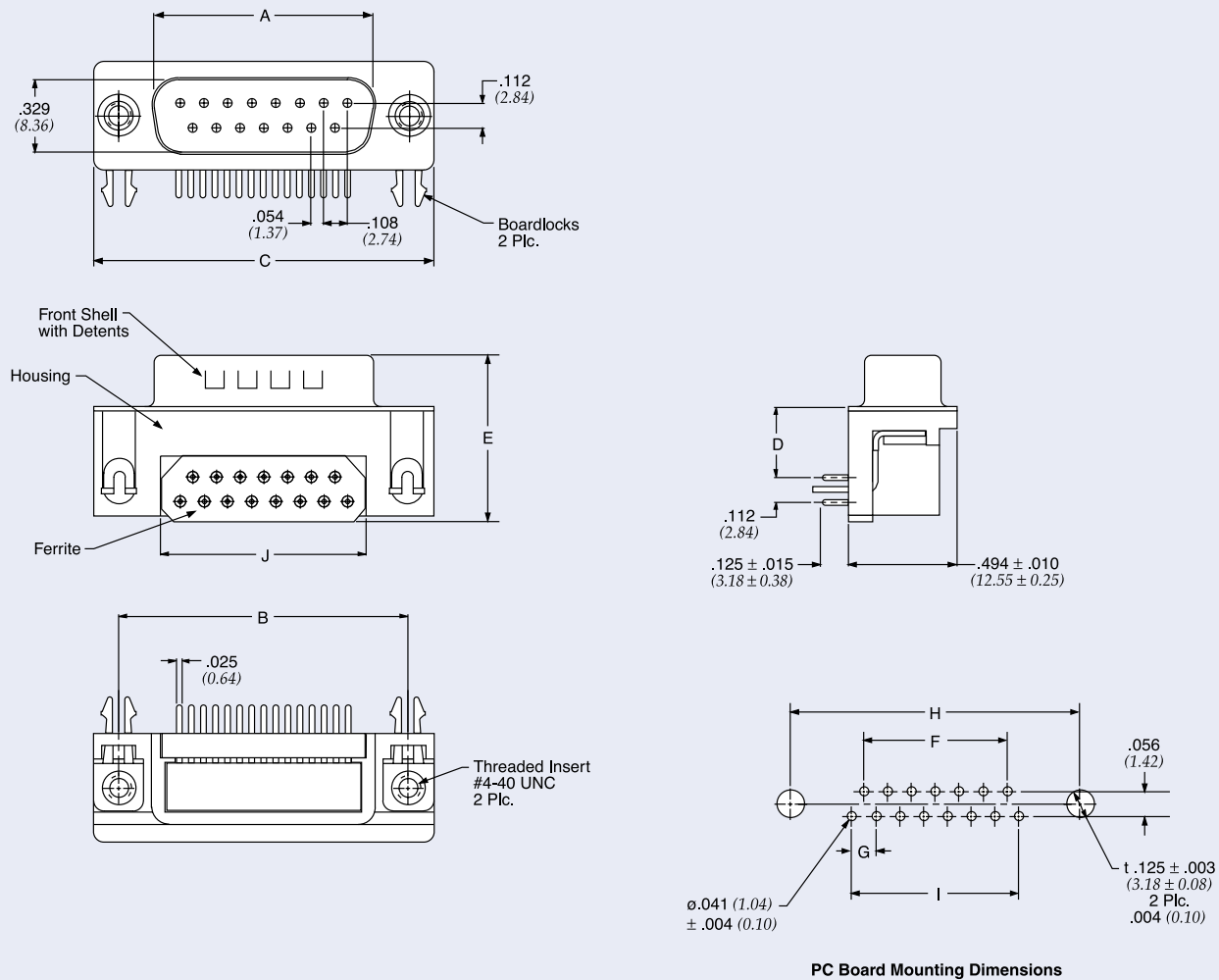

Filtered Connectors

Part Number	Description	Typ. Impedance (Ohms)		Frequency Range	A +/-	B +/-	C +/-	D +/-	E +/-	F +/-	G +/-	H +/-	I +/-	J +/-
		30 MHz	100 MHz		0.010 (0.25)	0.005 (0.13)	0.015 (0.38)	0.010 (0.25)	0.015 (0.38)	0.005 (0.13)	0.004 (0.10)	0.005 (0.13)	0.005 (0.13)	0.005 (0.13)
€ 56-402-001	D-Sub 9 pin	20	27	10 MHz to 300 MHz	0.666 (16.92)	0.984 (25.00)	1.213 (30.81)	0.318 (8.08)	0.751 (19.10)	0.162 (4.11)	0.054 (1.37)	0.492 (12.50)	0.216 (5.49)	0.606 (15.40)
€ 56-412-001	D-Sub 15 pin				0.994 (25.25)	1.312 (33.32)	1.541 (39.14)	0.318 (8.08)	0.751 (19.10)	0.324 (8.23)	0.054 (1.37)	0.656 (16.66)	0.378 (9.60)	0.929 (23.60)
€ 56-422-001	D-Sub 25 pin				1.534 (38.96)	1.852 (47.04)	2.088 (53.04)	0.318 (8.08)	0.751 (19.10)	0.598 (15.18)	0.055 (1.38)	0.926 (23.52)	0.652 (16.56)	1.476 (37.50)

€ Also available through Spectrum Control's authorized European distributors/agents.

Dimensions in inches (mm)

# Series F Ferrite Filtered Connectors

## Socket Contact – Right Angle Mount

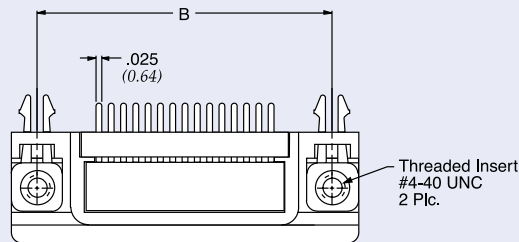
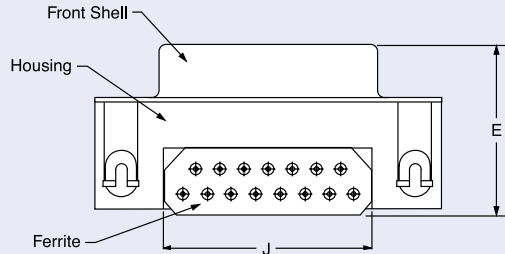
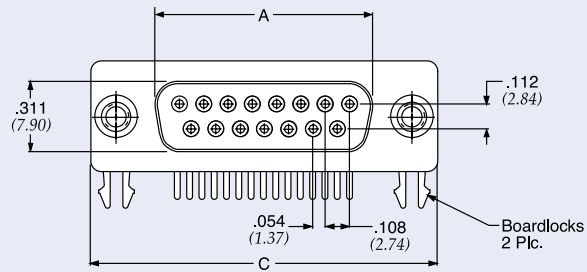

## \*Hi-Density

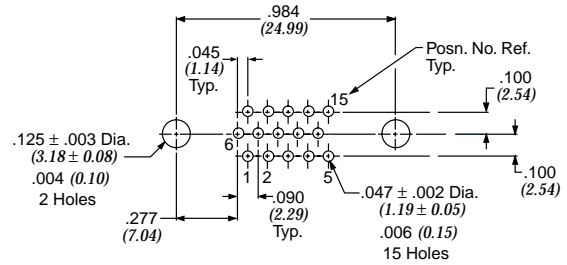
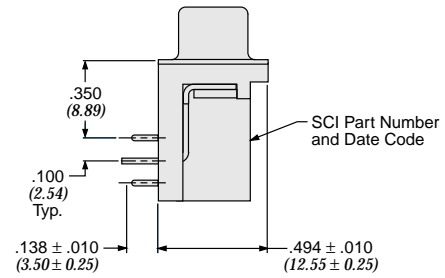

PC Board Mounting Dimensions

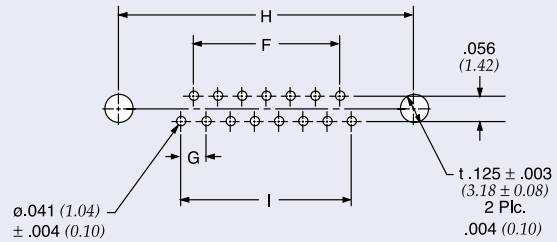
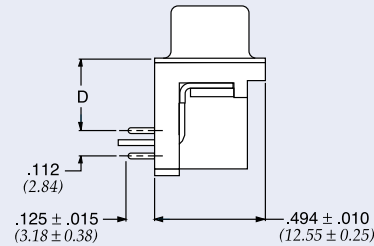

PC Board Mounting Dimensions

Part Number	Description	Typ. Impedance (Ohms)		Frequency Range	A +/-	B +/-	C +/-	D +/-	E +/-	F +/-	G +/-	H +/-	I +/-	J +/-
		30 MHz	100 MHz		0.010	0.005	0.015	0.010	0.015	0.005	0.004	0.005	0.005	0.005
€ 56-404-001	D-Sub 9 socket	20	27	10 MHz to 300 MHz	0.643 (16.33)	0.984 (25.00)	1.213 (30.81)	0.318 (8.08)	0.755 (19.20)	0.162 (4.11)	0.054 (1.37)	0.492 (12.50)	0.216 (5.49)	0.606 (15.40)
€ 56-414-001	D-Sub 15 socket				0.971 (24.66)	1.312 (33.32)	1.541 (39.14)	0.318 (8.08)	0.755 (19.20)	0.324 (8.23)	0.054 (1.37)	0.656 (16.66)	0.378 (9.60)	0.929 (23.60)
€ 56-424-001	D-Sub 25 socket				1.511 (38.38)	1.852 (47.04)	2.088 (53.04)	0.318 (8.08)	0.755 (19.20)	0.598 (15.18)	0.055 (1.38)	0.926 (23.52)	0.652 (16.56)	1.476 (37.50)
€ 56-414-001-HD	Hi-Density 15 socket				16	26	0.643 (16.33)	0.984 (25.00)	1.213 (30.81)	* See inset drawing				

€ Also available through Spectrum Control's authorized European distributors/agents.

Dimensions in inches (mm)

# Series F Ferrite Filtered Connectors

## Pin Contact – Vertical Mount

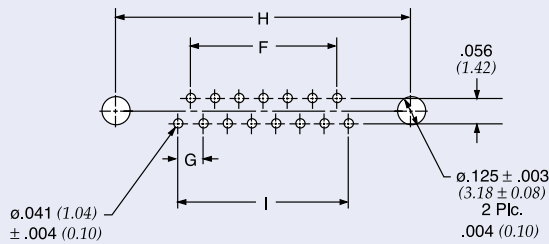
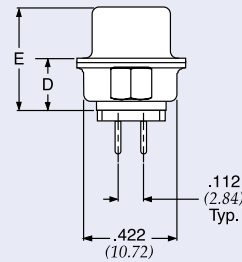
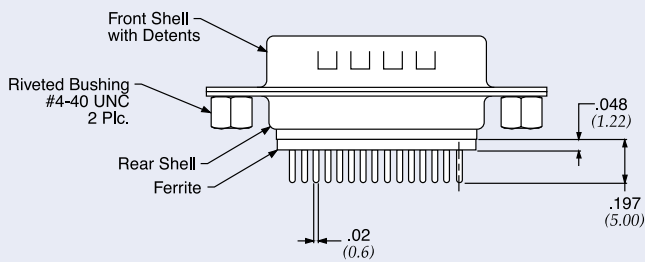
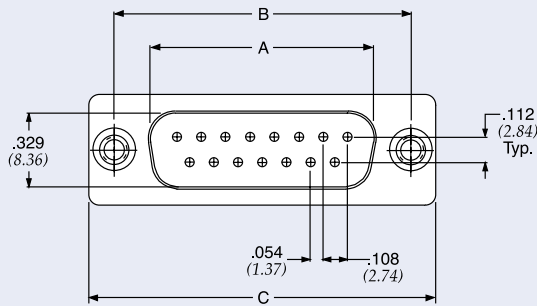

PC Board Mounting Dimensions

Part Number	Description	Typ. Impedance (Ohms)		Frequency Range	A +/-	B +/-	C +/-	D +/-	E +/-	F +/-	G +/-	H +/-	I +/-
		30 MHz	100 MHz		0.010 (0.25)	0.005 (0.13)	0.015 (0.38)	0.010 (0.25)	0.015 (0.38)	0.005 (0.13)	0.004 (0.10)	0.005 (0.13)	0.005 (0.13)
56-407-001	D-Sub 9 pin	10	15	10 MHz to 300 MHz	0.666 (16.92)	0.984 (25.00)	1.213 (30.81)	0.236 (5.99)	0.468 (11.88)	0.162 (4.11)	0.054 (1.37)	0.492 (12.50)	0.216 (5.49)
56-417-001	D-Sub 15 pin				.994 (25.25)	1.312 (33.32)	1.541 (39.14)	0.236 (5.99)	0.468 (11.88)	0.324 (8.23)	0.054 (1.37)	.656 (16.66)	0.378 (9.60)
56-427-001	D-Sub 25 pin				1.534 (38.96)	1.852 (47.04)	2.088 (53.04)	0.236 (5.99)	0.468 (11.88)	.598 (15.18)	0.055 (1.38)	.926 (23.52)	.652 (16.56)

Dimensions in inches (mm)

# Series F Ferrite Filtered Connectors

## Socket Contact – Vertical Mount

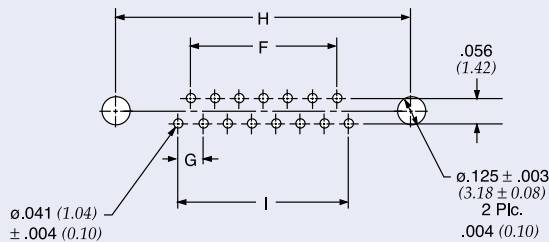
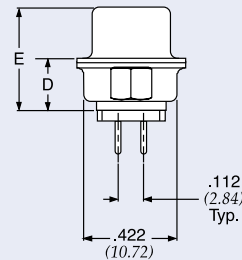
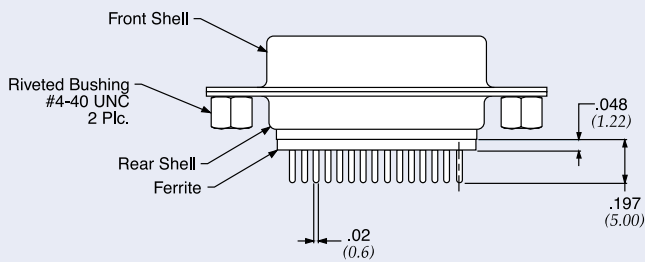
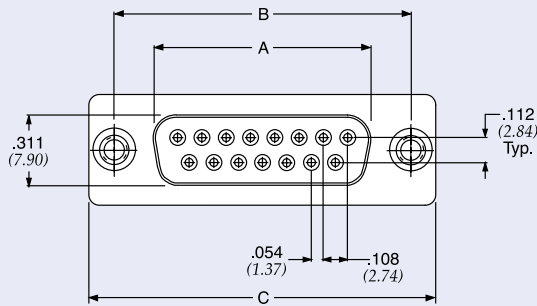

PC Board Mounting Dimensions

Part Number	Description	Typ. Impedance (Ohms)		Frequency Range	A +/-	B +/-	C +/-	D +/-	E +/-	F +/-	G +/-	H +/-	I +/-
		30 MHz	100 MHz		0.010 (0.25)	0.005 (0.13)	0.015 (0.38)	0.010 (0.25)	0.015 (0.38)	0.005 (0.13)	0.004 (0.10)	0.005 (0.13)	0.005 (0.13)
56-403-001	D-Sub 9 socket	10	15	10 MHz to 300 MHz	0.643 (16.33)	0.984 (25.00)	1.213 (30.81)	0.236 (5.99)	0.472 (11.98)	0.162 (4.11)	0.054 (1.37)	0.492 (12.50)	0.216 (5.49)
56-413-001	D-Sub 15 socket				.971 (24.66)	1.312 (33.32)	1.541 (39.14)	0.236 (5.99)	0.472 (11.98)	0.324 (8.23)	0.054 (1.37)	.656 (16.66)	0.378 (9.60)
56-423-001	D-Sub 25 socket				1.511 (38.38)	1.852 (47.04)	2.088 (53.04)	0.236 (5.99)	0.472 (11.98)	.598 (15.18)	0.055 (1.38)	.926 (23.52)	.652 (16.56)

Dimensions in inches (mm)

# Series 100 Chip-Cap Filtered Connectors

These versatile and widely used PCB connectors are an inexpensive filtering method that eliminates the problem of conductive electromagnetic interference (EMI).

Chip-cap plug and receptacles are available in 9, 15, 25 and 37 positions. These connectors are "drop-in" replacements for non-filtered D-subminiature connectors with matched PCB footprints. Housings are made of UL 94V-0 rated thermoplastic material. Low cost front metal shells are compatible with full metal-shell threaded insert mating hardware. Integral boardlocks secure posted connectors to the PC board, prior to soldering.

## Features

- Offer economical, high performance EMI/RFI protection
- Matched .318", .405" and .590" PCB footprints mean "Drop-in" replacement for non-filtered connectors
- Chip capacitors on a PC board
- Connectors have industry standard interface
- Connector housing made of UL 94V-0 rated high temperature, thermoplastic
- Connector body is recognized under the Component Program of Underwriters Laboratories, Inc.
- Connector body is certified by the Canadian Standards Association

## Mechanical Specifications

<i>Front Shell</i> . . . . .	Steel, tin plated
<i>Housing</i> . . . . .	94V-0 rated thermoplastic, black
<i>Eyelets</i> . . . . .	Brass, tin plated
<i>Threaded Inserts</i> . . . . .	Zinc
<i>Boardlocks</i> . . . . .	Copper alloy, tin-lead plated
<i>Pin Contacts</i> . . . . .	Brass
<i>Socket Contacts</i> . . . . .	Phosphor Bronze
<i>Contact Plating</i> . . . . .	Duplex plated as follows: 15uin (.38um) gold on mating end, with entire contact 50uin (1.27um) min. nickel underplated.



## Typical Insertion Loss

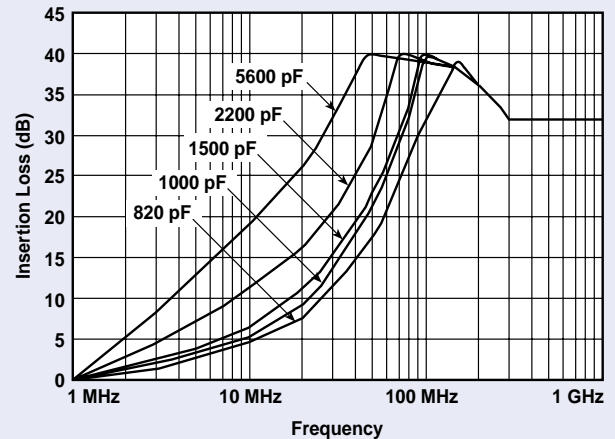
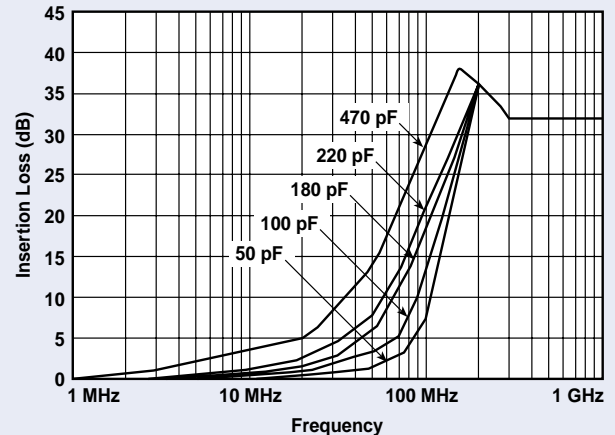

## Performance Specifications

- Current Rating* . . . . . 5 Amps
- Contact Resistance* . . . . . 8 Milliohms max.
- Capacitance* . . . . . 50, 100, 180, 220, 470, 820, 1,000, 1,500, 2,200, 5,600 pF and 47 nF ± 20%
- Dielectric Withstanding Voltage* . . . . . 700 VDC min. for 5 sec.
- Insulator Resistance* . . . . . 500 Megohms min. @ 100 VDC
- Working Voltage* . . . . . 200 VDC

# Series 100 Chip-Cap Filtered Connectors

## Ordering Information

Example: **56-104-004-5-T**

This part number represents a Series 100 connector with a shell size of 9 and a socket to right angle configuration. The capacitance value is 470 pF and the connector has a .590" footprint with 4-40 threads.

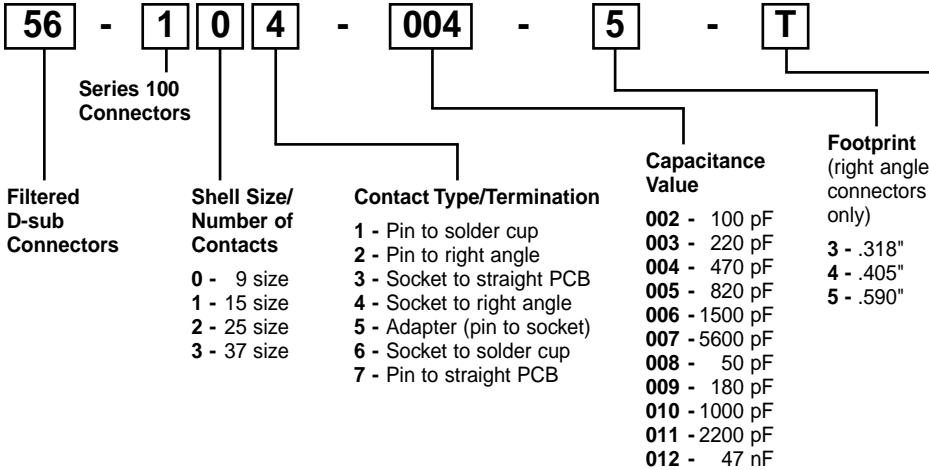

- Mounting or Hardware Options**
- .120 thru-hole and 15μ" gold
  - 3G** - 30μ" gold
  - 5G** - 50μ" gold
- SC and Straight PCBs**
- TIB** - 4-40 thread on rear of flange
  - TIF** - 4-40 thread on front of flange
  - MIB** - M3 thread on rear of flange
  - GBL6** - for .062" boards
  - JS** - Jack screws
- Right Angles and Adapters**
- No GBL attached
  - GL** - includes grounding board lock and 4-40 threads
  - T** - 4-40 threads
  - GB** - no board locks
  - J** - jack screws
  - M** - M3 thread

## Board Layouts

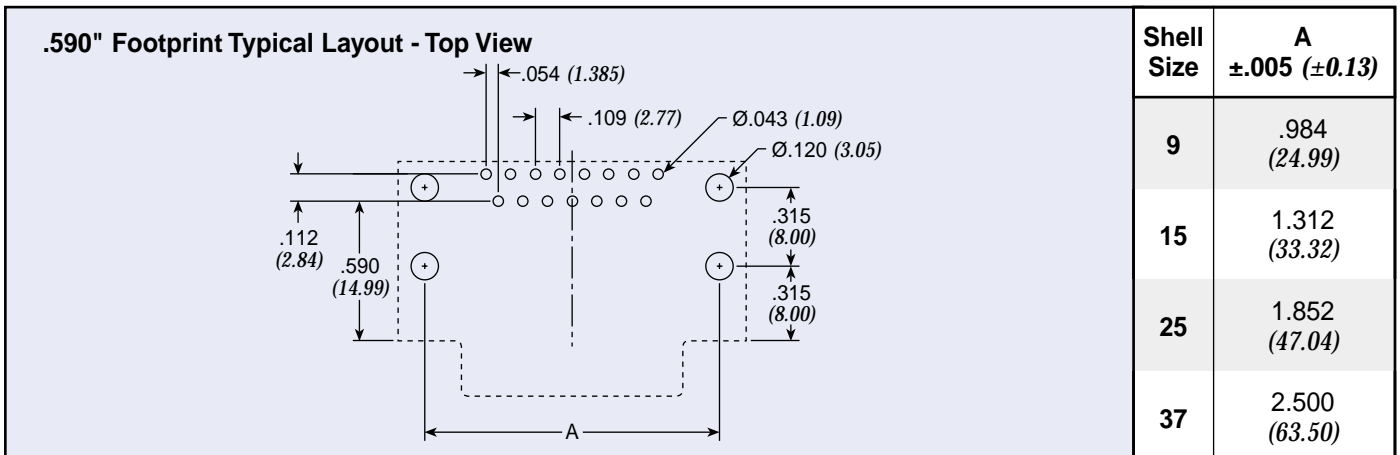
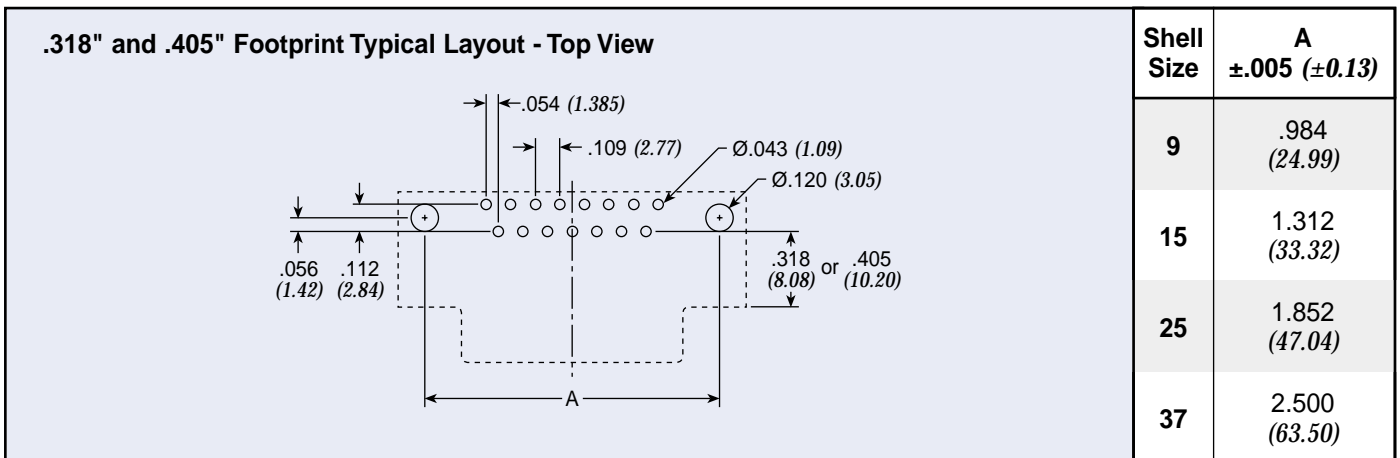

Dimensions in inches (mm)

# Series 100 Chip-Cap Filtered Connectors

## Pin Contact (plug) Straight PC Mount

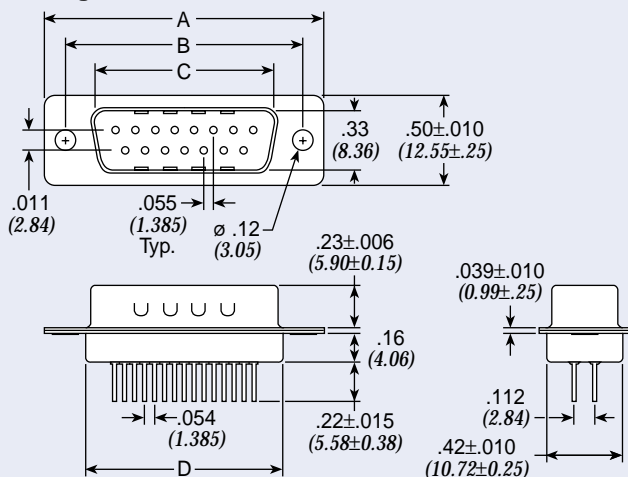

## 90° PC Mount

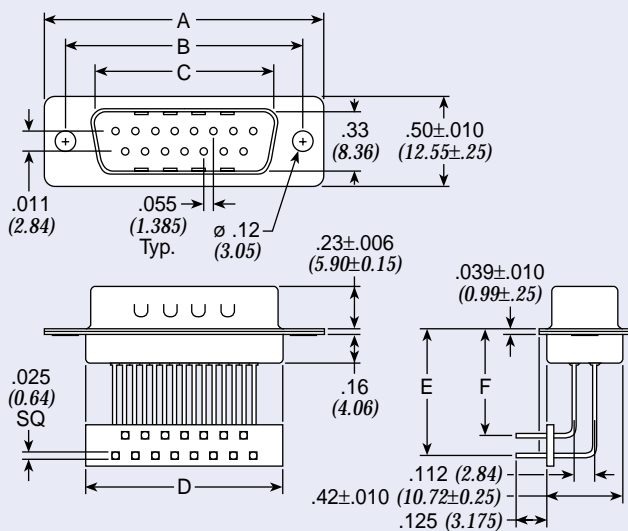

Size	A	B	C	D
9	1.213±.015 (30.81±0.38)	.984±.005 (24.99±0.13)	.667±.010 (16.92±0.25)	.755 (19.18)
15	1.541±.015 (39.14±0.38)	1.312±.005 (33.32±0.13)	.994±.010 (25.25±0.25)	1.083 (27.51)
25	2.088±.015 (53.04±0.38)	1.852±.005 (47.04±0.13)	1.534±.010 (38.96±0.25)	1.614 (41.00)
37	2.73±.015 (69.32±0.38)	2.50±.005 (63.50±0.13)	2.18±.010 (55.42±0.25)	2.27 (57.71)

Footprint	E	F
.318	.430 (10.92)	.318 (8.08)
.405	.517 (13.13)	.405 (10.29)
.590	.700 (17.83)	.590 (14.99)

Dimensions in inches (mm)

## Socket Contact (receptacle) Straight PC Mount

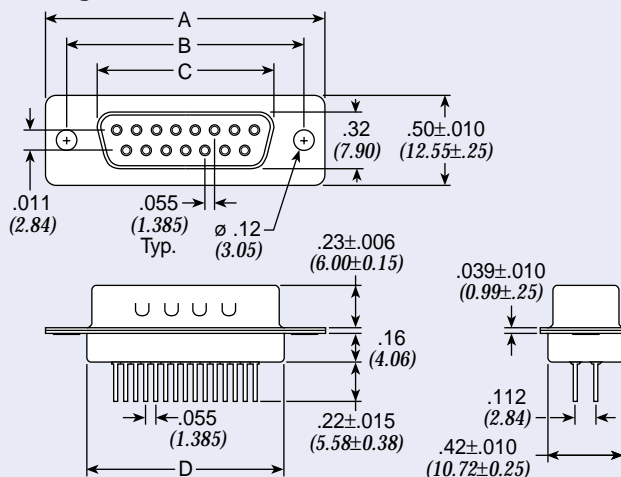

## 90° PC Mount

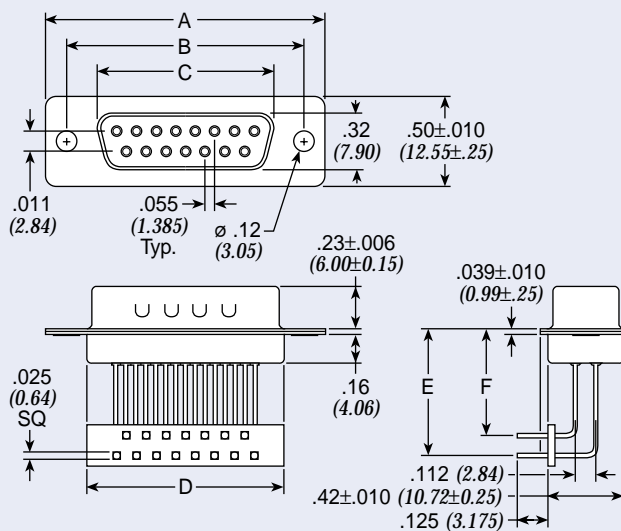

Size	A	B	C	D
9	1.213±.015 (30.81±0.38)	.984±.005 (24.99±0.13)	.643±.010 (16.33±0.25)	.755 (19.18)
15	1.541±.015 (39.14±0.38)	1.312±.005 (33.32±0.13)	.971±.010 (24.66±0.25)	1.083 (27.51)
25	2.088±.015 (53.04±0.38)	1.852±.005 (47.04±0.13)	1.511±.010 (38.38±0.25)	1.614 (41.00)
37	2.73±.015 (69.32±0.38)	2.50±.005 (63.50±0.13)	2.16±.010 (54.84±0.25)	2.27 (57.71)

Footprint	E	F
.318	.430 (10.92)	.318 (8.08)
.405	.517 (13.13)	.405 (10.29)
.590	.700 (17.83)	.590 (14.99)

Dimensions in inches (mm)

# Series 100 Chip-Cap Filtered Connectors

## Pin Contact (plug) Solder Cup Termination

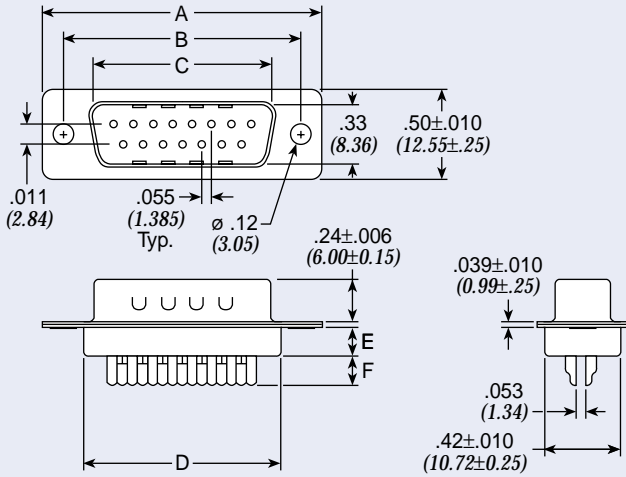

## Socket Contact (receptacle) Solder Cup Termination

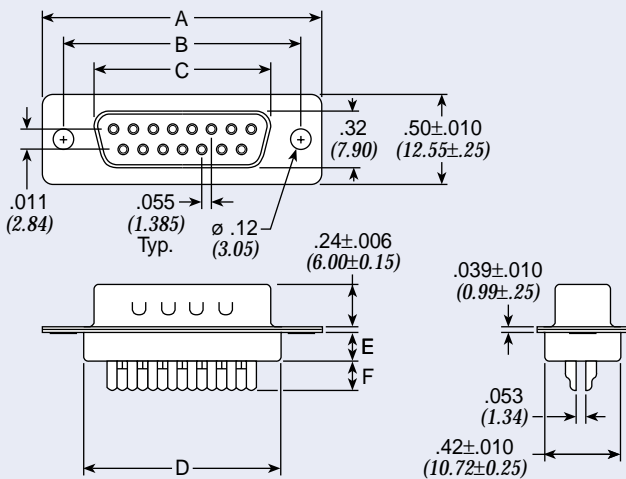

Size	A	B	C	D	E	F
9	1.213±.015 (30.81±0.38)	.984±.005 (24.99±0.13)	.643±.010 (16.33±0.25)	.755 (19.18)	.16 (4.06)	.16 (4.06)
15	1.541±.015 (39.14±0.38)	1.312±.005 (33.32±0.13)	.971±.010 (24.66±0.25)	1.083 (27.51)	.16 (4.06)	.16 (4.06)
25	2.089±.015 (53.04±0.38)	1.852±.005 (47.04±0.13)	1.511±.010 (38.38±0.25)	1.615 (41.00)	.16 (4.06)	.16 (4.06)
37	2.73±.015 (69.32±0.38)	2.50±.005 (63.50±0.13)	2.16±.010 (54.84±0.25)	2.27 (57.71)	.16 (4.06)	.16 (4.06)

Dimensions in inches (mm)

## Pin - Socket Adapter

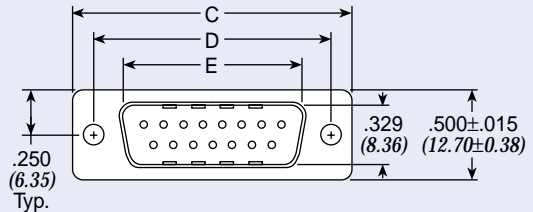
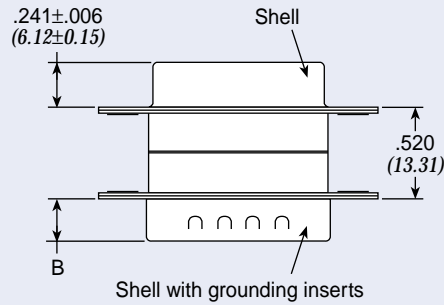
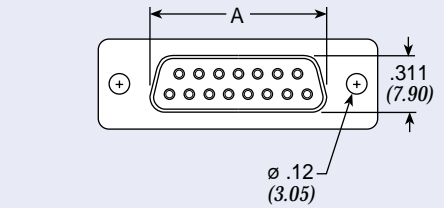

Size	A	B	C	D	E
9	.642 (16.31)	.233±.006 (5.92±.15)	1.213±.015 (30.81±.38)	.984 (24.99)	.667 (16.94)
15	.970 (24.64)	.233±.006 (5.92±.15)	1.541±.015 (39.14±.38)	1.312 (33.33)	.995 (25.27)
25	1.511 (38.38)	.228±.006 (5.80±.15)	2.088±.015 (53.04±.38)	1.852 (47.05)	1.532 (38.92)
37	2.158 (54.82)	.228±.006 (5.80±.15)	2.729±.015 (69.32±.38)	2.500 (63.50)	2.183 (55.45)

Dimensions in inches (mm)

## Series 500 Low Profile Filtered Connectors

Spectrum Control's Series 500 are cost effective, highly reliable EMI filtered D-subminiature connectors that feature a .318" footprint for 90 degree PCB connectors and a low profile housing on straight PCB connectors. Series 500 filtered D-sub are "drop-in" replacements for standard unfiltered D-sub connectors.

The ability of these connectors to achieve EMI filtering within the smaller footprint is the result of technical advances in ceramic capacitors. Series 500 connectors use tubular capacitors for high performance EMI filtering. Quality features for these connectors include board lock mounting, metal front shells and gold plated contacts.

Series 500 capacitive filtered D-sub connectors are an ideal solution to FCC/EC/VCCI emissions problems. These connectors are designed to protect equipment from external EMI noise and eliminate system glitches.

### Series 500 Applications

- Personal computers
- Industrial process equipment
- Graphics workstations
- PBX telecommunications equipment
- Cellular base stations and medical electronics



### Features

- "Drop-in" replacements for unfiltered D-subminiatures
- Compact design, featuring .318" footprint
- Tubular feed-thru capacitors provide filtering superior to on-board components
- Ground plane design provides EMI shielding
- Full interchangeability; based on MIL-C-24308
- Each connector position is tested 100% for critical electrical parameters to ensure consistent performance
- Insulators are UL recognized UL94-V0 flammability rated
- 9, 15 and 25 shell sizes
- Available with board lock feature and 4-40 mounting threads
- Selective filtering available
- UL/CSA approval pending
- Greater than 40 dB filtering up through 1 GHz without resonances
- Bi-Directional control of EMI at the I/O ports

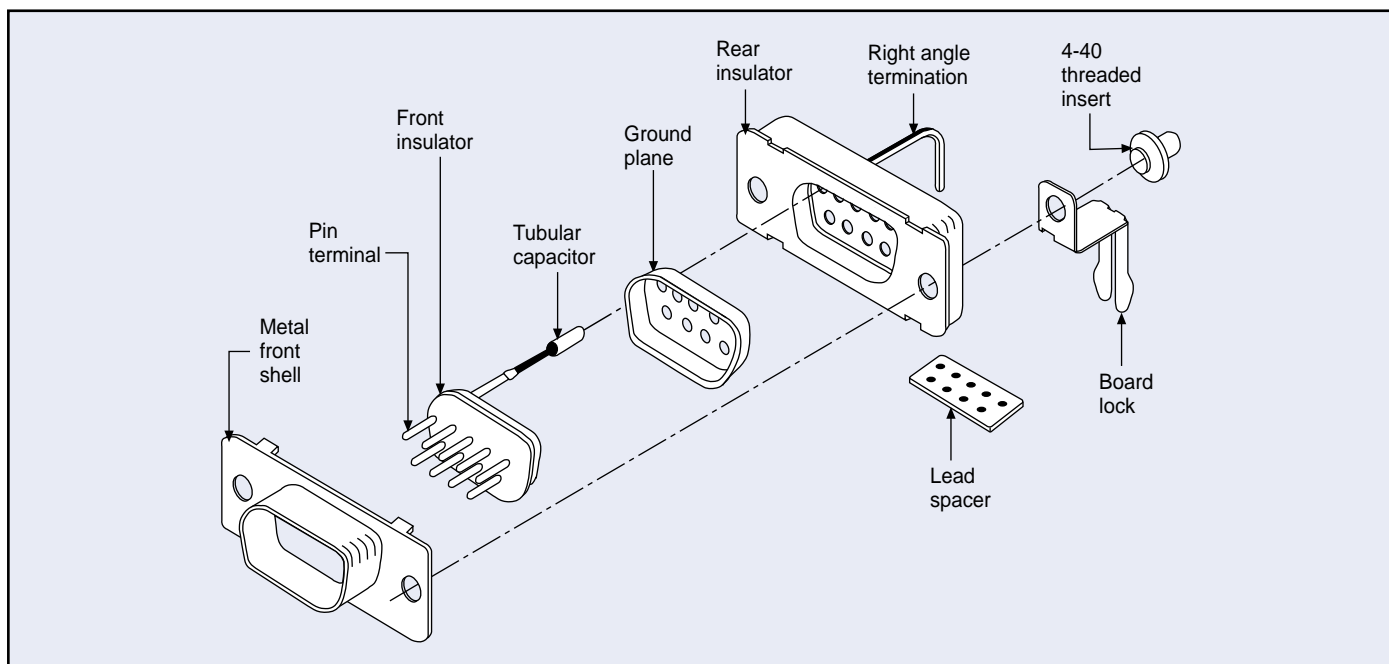

# Series 500 Low Profile Filtered Connectors



## Mechanical Specifications

- Shell** . . . . . Steel, tin plated
- Insulators** . . . . . Glass-filled polyester, flammability UL94V-O
- Pin Contacts** . . . . . Copper alloy CA725, 15 microinch (0.38 μm) gold plated\* over nickel
- Socket Contacts** . . . . . Copper alloy CA725, 30 microinch (0.76 μm) gold plated\* over nickel
- \* Heavier gold plating available upon request.
- Ground Plane** . . . . . Phosphor bronze, nickel plated
- Operating Temperature** . . . . . -40°C to +125°C
- Capacitors** . . . . . Proprietary barium titanate ceramic formulations

Other environmental tests such as shock, vibration, humidity, etc. are performed as detailed in our filtered connector performance specifications on page 197.

## Electrical Specifications

- Current Rating** . . . . . 5 Amps
- RF Current Rating** . . . . . 0.3 Amps
- Contact Resistance** . . . . . 10 milliohms maximum
- Capacitance** . . . . . 120, 440, 840, 1000, 1500 pF ±30%
- Working Voltage** . . . . . 100 VDC
- Dielectric Withstanding Voltage** . . . . . 300 VDC
- Insulation Resistance** . . . . . 1 Gohm minimum
- UL Recognized** . . . . . Under category of communication circuit accessories, File #E149046

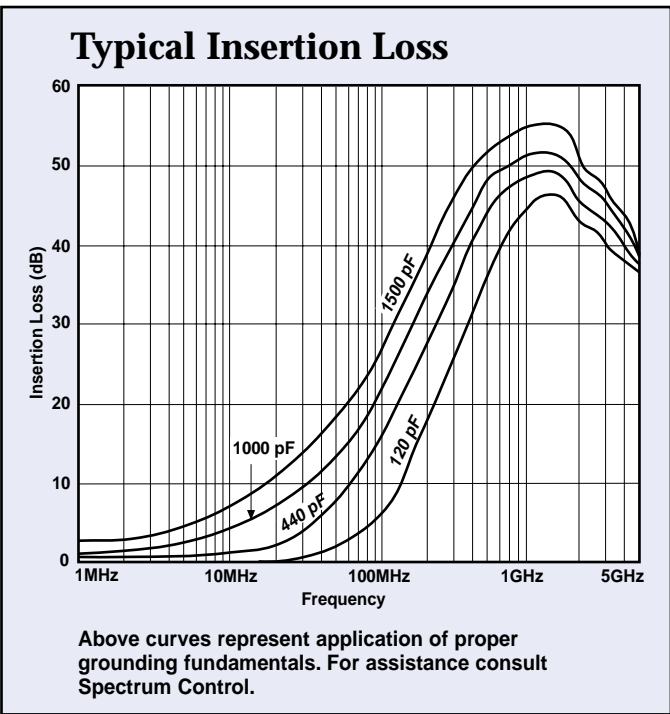

840 pF is typically within 2 dB of 1000 pF curve.

## Filter Performance

Cap. (pF) Value ±30%	3 dB Cut-off Freq. (MHz)	Insertion Loss (dB)					
		20 MHz	100 MHz	500 MHz	1 GHz	2 GHz	5 GHz
120	40	–	4	21	26	26	20
440	11	3	15	27	33	32	25
840	6	6	19	32	38	37	25
1000	3	8	21	35	41	38	25
1500	2	10	25	40	47	42	25

Insertion loss measured per MIL-STD-220, no load, 50 ohm source and load. Above data represents guaranteed minimum.

Filtered Connectors

# Series 500 Low Profile Filtered Connectors

## Pin Contact (plug) Straight PC Mount

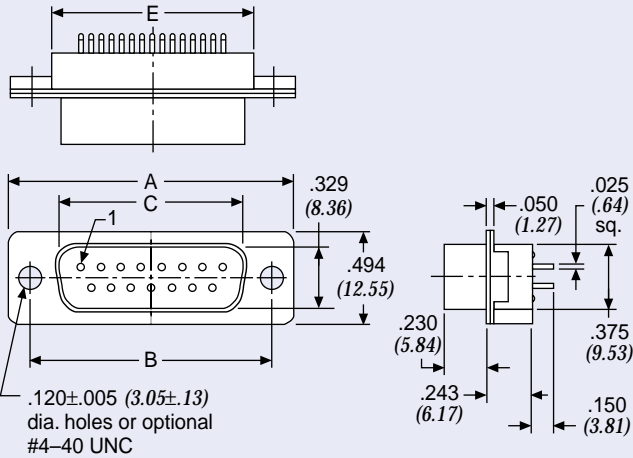

## 90° PC Mount

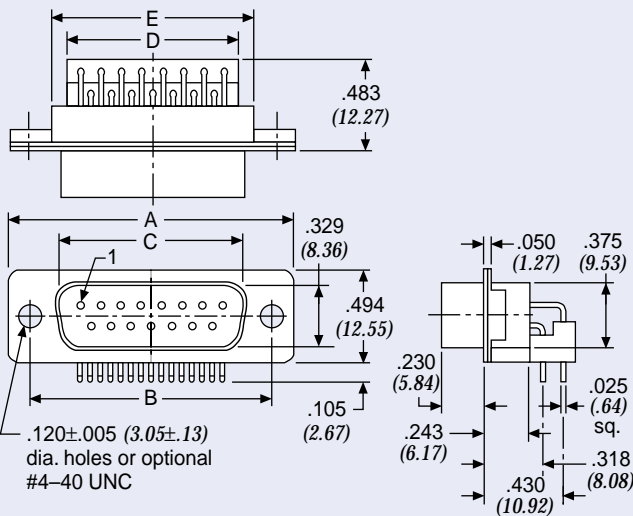

Size	A	B	C	D	E
9	1.213 (30.81)	0.984 (24.99)	0.666 (16.92)	0.540 (13.72)	0.748 (19.00)
15	1.541 (39.14)	1.312 (33.32)	0.994 (25.25)	0.867 (22.02)	1.076 (27.33)
25	2.088 (53.04)	1.852 (47.04)	1.534 (38.96)	1.412 (35.86)	1.616 (41.05)

Standard Tolerance = ±.015 (0.38)

Dimensions in inches (mm)

## Socket Contact (receptacle) Straight PC Mount

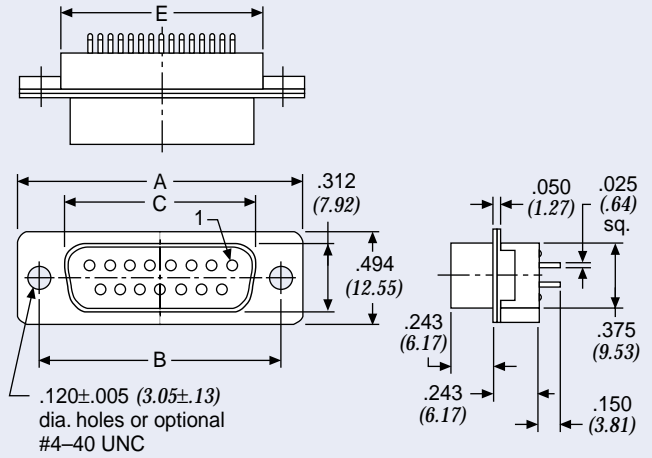

## 90° PC Mount

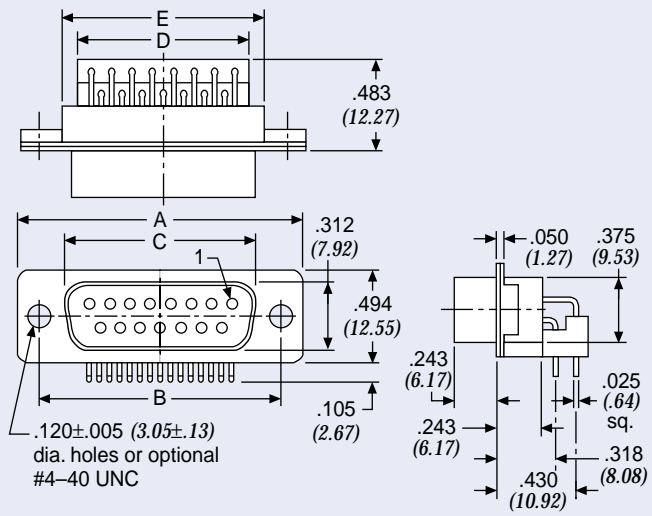

Size	A	B	C	D	E
9	1.213 (30.81)	0.984 (24.99)	0.642 (16.31)	0.540 (13.72)	0.748 (19.00)
15	1.541 (39.14)	1.312 (33.32)	0.970 (24.64)	0.867 (22.02)	1.076 (27.33)
25	2.088 (53.04)	1.852 (47.04)	1.510 (38.35)	1.412 (35.86)	1.616 (41.05)

Standard Tolerance = ±.015 (0.38)

Dimensions in inches (mm)

# Series 500 Low Profile Filtered Connectors

## Ordering Information

Example: **56-524-013-GBL**



<b>56</b>	<b>5</b>	<b>2</b>	<b>4</b>	<b>013</b>	<b>GBL</b>
<b>Filtered D-sub Connectors</b>	<b>Series 500 Connectors</b>	<b>Shell Size/ Number of Contacts</b>		<b>Contact Type/Termination</b>	
		<b>0</b> - 9 size		<b>2</b> - Pin to 90° PCB mount	
		<b>1</b> - 15 size		<b>3</b> - Socket to straight PCB mount	
		<b>2</b> - 25 size		<b>4</b> - Socket to 90° PCB mount	
				<b>7</b> - Pin to straight PCB mount	

This part number represents a Series 500 filtered D-sub connector with 25 contacts, socket to 90° PCB mount configuration. The filter has a capacitance value of 1000 pF and the connector includes a grounded board lock.

For special needs or combinations of features, contact Spectrum Control engineering.

<b>Capacitance Value</b>	<b>Mounting or Hardware Options</b>
<b>010</b> - 120 pF	<b>TI</b> - 4-40 threads on mounting flange (.120" (3.05mm) hole if not selected)
<b>011</b> - 440 pF	<b>GBL</b> - Grounded board lock, includes 4-40 threads (available only on 90° PCB)
<b>012</b> - 840 pF	<b>GBLF</b> - Grounded board lock and ferrite slab, provides the enhanced performance of an (LC) filter (available only on 90° PCB)
<b>013</b> - 1000 pF	
<b>014</b> - 1500 pF	

## GBL Option

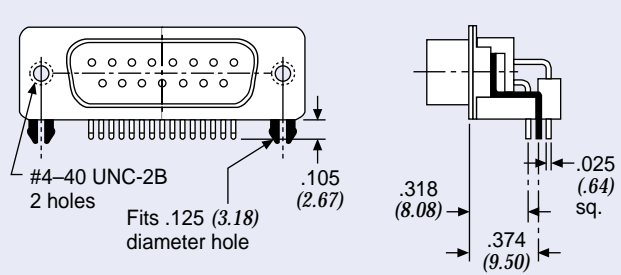

**Features**

- Snap-in retention to PC board, requires no hardware
- Ensures low ground impedance for superior filtering
- 4-40 threads on mounting flange eliminate loose hardware

Dimensions in inches (mm)

## Board Layout

**Typical Layout for .318" (8.08) Footprint**

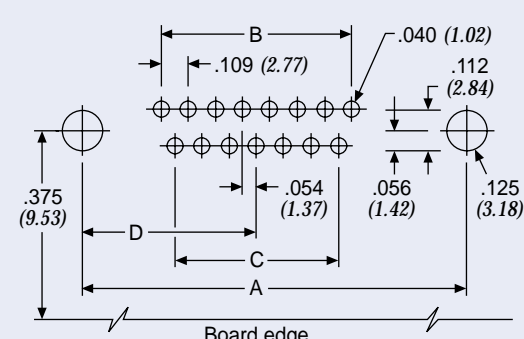

Shell Size	A	B	C	D
<b>9</b>	.984 (24.99)	.436 = 4 x .109 (11.07 = 4 x 2.77)	.327 = 3 x .109 (8.31 = 3 x 2.77)	.492 (12.50)
<b>15</b>	1.312 (33.32)	.763 = 7 x .109 (19.38 = 7 x 2.77)	.654 = 6 x .109 (16.61 = 6 x 2.77)	.656 (16.66)
<b>25</b>	1.852 (47.04)	1.308 = 12 x .109 (33.22 = 12 x 2.77)	1.199 = 11 x .109 (30.45 = 11 x 2.77)	.926 (23.52)

Dimensions in inches (mm)

# Series 600 Hi-Density Filtered Connectors

The miniaturization of electronic systems and sub-systems is pushing designers to increase circuit densities within smaller packages. To address this growing need, Spectrum Control has developed a line of filtered Hi-Density D-subminiature connectors. This new line of connectors incorporates the high performance and reliable filtering of Spectrum's standard D-sub's in the Hi-Density format.

## Features

- Connectors designed to MIL-C-24308
- Capacitance values from 85 pF to 4000 pF
- Filter type feed-thru C
- Selectively specify and filter each contact position
- Available in feed-thru capacitive configurations

## Mechanical Specifications:

Same as Series 700 connectors, page 147.

## Electrical Specifications: Hi-Density Connectors

Filter Designations	Filter Circuits	Capacitance		3 dB Cut-off Frequency Max. (MHz)	Dielectric With-standing Voltage	Working Voltage DC -55°C to +125°C	Minimum Insertion Loss - Decibels (dB)									
		Value	Tol.				5 MHz	10 MHz	20 MHz	50 MHz	100 MHz	200 MHz	500 MHz	1 GHz	2 GHz	5 GHz
15	C	85 pF	±25%	60	300V	100V	—	—	—	—	1	6	16	21	22	20
16		180 pF	±25%	28	300V	100V	—	—	—	1	8	10	18	25	26	24
18		1000 pF	±25%	5.1	300V	100V	—	3	8	14	20	25	32	35	41	39
19		4000 pF	±25%	1.3	300V	100V	8	13	19	26	31	37	45	48	52	47

Filter designation "G" for grounded contacts, "I" for insulated (not filtered) contacts. Filter designation "O" for omitted contact and no hole in ground plane.

Above data represents guaranteed minimum.

## Ordering Information

Example: **56-605-015-LI**

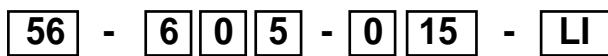

D-Sub Connector  
Hi-Density

Shell Size\*\*  
0 = 15  
1 = 26  
2 = 44  
3 = 62  
4 = 78

Contact/Termination  
1 - Pin to solder cup  
2 - Pin to 90° PCB mount  
3 - Socket to PCB mount  
4 - Socket to 90° PCB mount  
5 - Pin-socket adapter  
7 - Pin to PCB mount

Special  
0 = All positions same  
9 = Special loading

Some shell sizes require minimum order quantity. Consult Spectrum Control for details.

This part number represents a Series 600 Hi-Density filtered D-Sub connector with 15 contacts, pin-socket adapter configuration. The FT filters have a capacitance value of 85 pF and the connector includes 4-40 locking inserts.

Filter Designation  
15 - 85 pF FT  
16 - 180 pF FT  
18 - 1,000 pF FT  
19 - 4,000 pF FT  
20 - Insulated contact

Options  
LI = 4-40 inserts  
S = Solder dip tails  
50G = μ gold

## Typical Insertion Loss

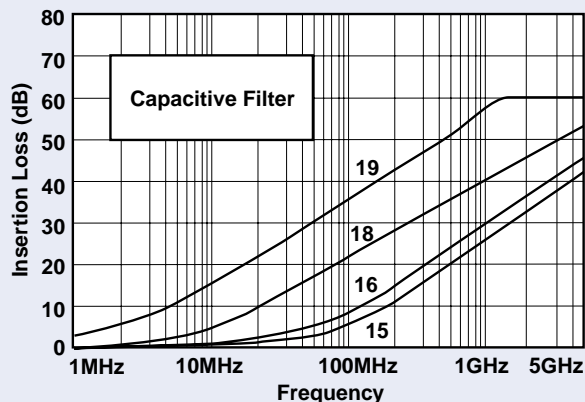

Above curves represent application of proper grounding fundamentals, for assistance consult with Spectrum Control.

Insertion loss measured per MIL-STD-220, no load, 50 ohm source and load.

# Series 600 Hi-Density Filtered Connectors



## Pin/Socket Adapter

Size	A	B	C	D	E	F	G
15	1.213 (30.81)	.984 (24.99)	.640 (16.26)	.304 (7.72)	.505 (12.83)	.666 (16.92)	.333 (8.46)
26	1.541 (39.14)	1.312 (33.32)	.968 (24.59)	.304 (7.72)	.505 (12.83)	.994 (25.25)	.333 (8.46)
44	2.088 (53.04)	1.852 (47.04)	1.508 (38.30)	.304 (7.72)	.505 (12.83)	1.534 (38.96)	.333 (8.46)
62	2.729 (69.32)	2.500 (63.50)	2.156 (54.76)	.304 (7.72)	.505 (12.83)	2.182 (55.42)	.333 (8.46)
78	2.635 (66.93)	2.406 (61.11)	2.062 (52.37)	.416 (10.57)	.615 (15.62)	2.079 (52.81)	.420 (11.18)

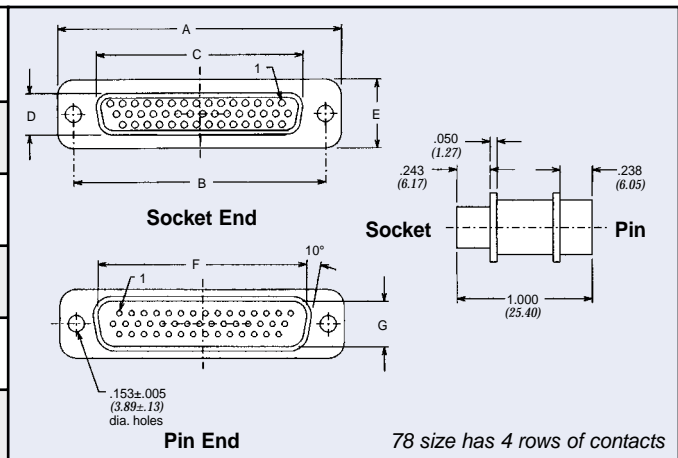

## Pin or Socket to Solder Cup, PCB Mount and 90° PCB Mount

Size	A	B	C	D	E	F	G
15	1.213 (30.81)	.984 (24.99)	.505 (12.83)	.666 (16.92)	.333 (8.46)	.757 (19.23)	.420 (10.67)
26	1.541 (39.14)	1.312 (33.32)	.505 (12.83)	.994 (25.25)	.333 (8.46)	1.085 (27.56)	.420 (10.67)
44	2.088 (53.04)	1.852 (47.04)	.505 (12.83)	1.534 (38.96)	.333 (8.46)	1.625 (41.28)	.420 (10.67)
62	2.729 (69.32)	2.500 (63.50)	.505 (12.83)	2.182 (55.42)	.333 (8.46)	2.273 (57.73)	.420 (10.67)
78	2.635 (66.93)	2.406 (61.11)	.615 (15.62)	2.079 (52.81)	.440 (11.18)	2.170 (55.12)	.527 (13.39)

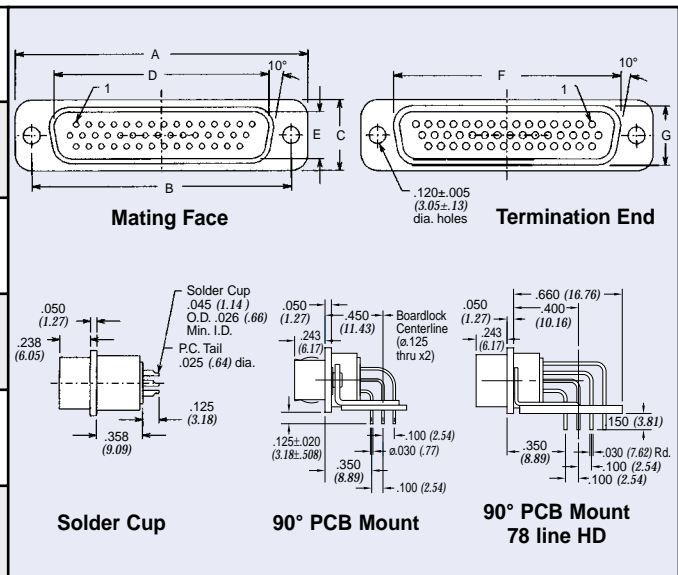

Dimensions in inches (mm)

# Hi-Density Filtered Adapter for Telecommunications

Within the telecommunications industry, it has been standard practice to use an adapter (male/female) type of EMI filtered connector as the interface between the switching system electronics and the premise wiring. These filtered adapters provide effective containment of EMI compared to either D-subminiature or 50-position "ribbon" contact type connectors.

The following several factors have mandated the development of a new generation of filtered adapters.

## Special Requirements

- Higher density wiring
- The need for more contacts, usually a multiple of 16
- Higher reliability contact geometries
- Bellcore TR-NWT-001089 requirements
  - 1000 volts AC withstand for one minute
  - 2500 volts spike surge testing
- Improved flammable resistant plastic insulators

Spectrum Control, in response to these unique requirements of the telecommunication industry, has developed a new Hi-Density filtered adapter.

## Features

- New ceramic technology and filter element construction to accept higher voltages
- Improved reliability compared to "ribbon" type connectors
- Integral ground plane and one-piece diecast housing for the highest level of EMI integrity
- More contacts/wires per square inch of panel space through Hi-Density arrangements
- 64 contact positions standard, with 78 positions available by request in any filter combination



## Mechanical Specifications

- Shell* . . . . . Zinc diecast, nickel plated  
150  $\mu$  inches (3.81  $\mu$ m) min.
- Insulators* . . . . . Thermoplastic, UL94V-0
- Contacts* . . . . . One-piece, screw machined  
Copper alloy, contact area plated  
50  $\mu$  inches (1.27  $\mu$ m) gold  
over 50  $\mu$  inches (1.27  $\mu$ m) nickel
- Ground Plane* . . . . . Brass, solder plated
- Grounding Springs* . . . . . Beryllium copper, tin plated per MIL-T-10727
- Operating Temperature* . . . . . -55°C to +125°C
- Capacitor* . . . . . High performance ceramic feed-thru utilizing ultra low ESR design

## Electrical Specifications

- Rated Voltage* . . . . . 100 VDC
- Current Rating* . . . . . 3 Amps
- DC Resistance* . . . . . 15 milliohm max.
- Dielectric Withstanding Voltage* . . . . . 1000 VRMS (FCC Part 68 test)
- Capacitance* . . . . . 1000 pF,  $\pm$ 25%
- Voltage Surge* . . . . . meets 2500 volts surge (10/1000)  
(See Wave form figure on next page)

# Hi-Density Filtered Adapter for Telecommunications

## Filter Performance

Minimum Insertion Loss	
20 MHz	7 dB
50 MHz	14 dB
100 MHz	20 dB
500 MHz	32 dB
1 GHz	35 dB
2 GHz	41 dB
5 GHz	39 dB

Insertion loss measured per MIL-STD-220, no load, 50 ohm source and load. Above data represents guaranteed minimum.

## Part Number for Ordering: #56-645-002

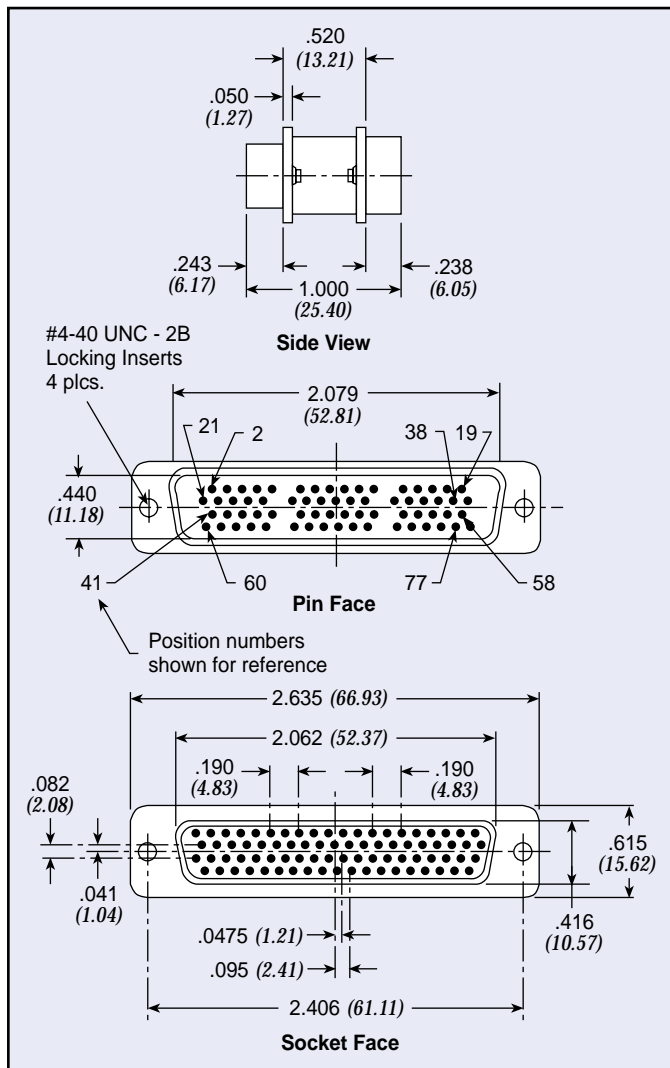

Dimensions in inches (mm)

## Typical Insertion Loss

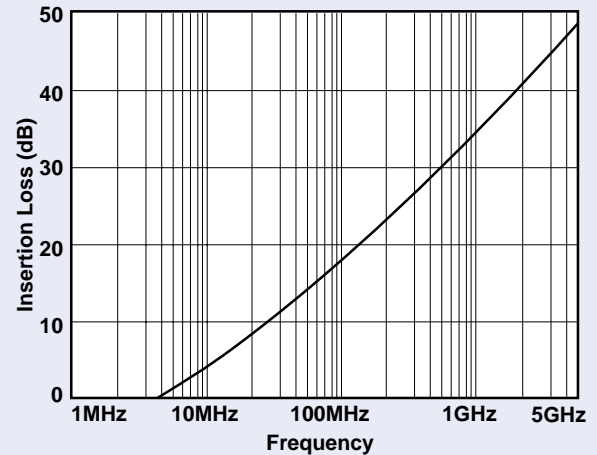

Above curves represent application of proper grounding fundamentals, for assistance consult with Spectrum Control.

## Pulse Wave Form\* (10 x 1000)

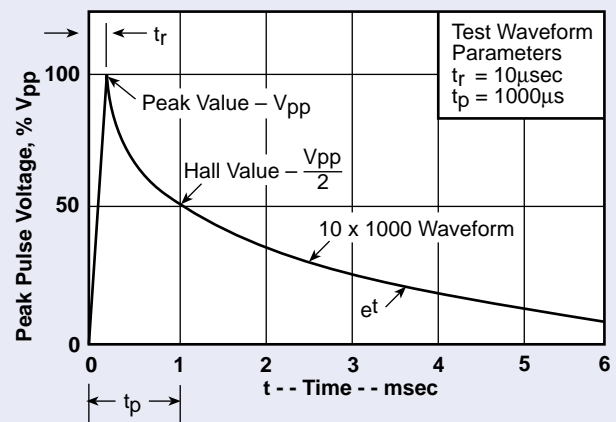

\* Reference Bellcore TR-NWT-1089, V<sub>pp</sub> = 1000V

# Series 700 High Performance Filtered Connectors

## Filter Selection

Spectrum Control Series 700 connectors offer the highest performance filtering for all types of professional applications.

## Features

- Available in 9, 15, 25, 37 and 50 shell sizes
- Variety of termination configurations including right angle and straight PCB for both pin and socket contact and as an adapter
- Capacitive and Pi type filters in a full range of capacitance values

The catalog data for this series is presented in order of shell size, and grouped by pin and socket contacts. Part numbers must be selected from the tables within the series section.

## Typical Insertion Loss

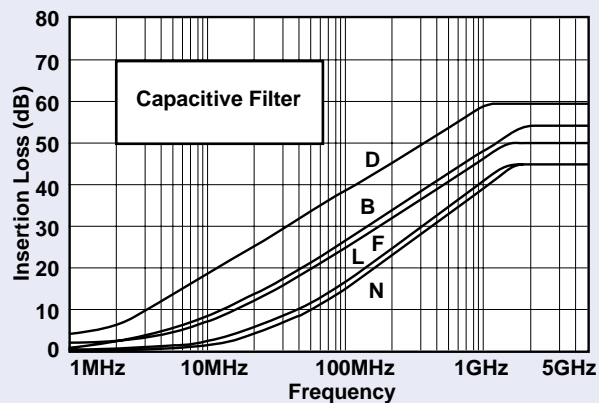
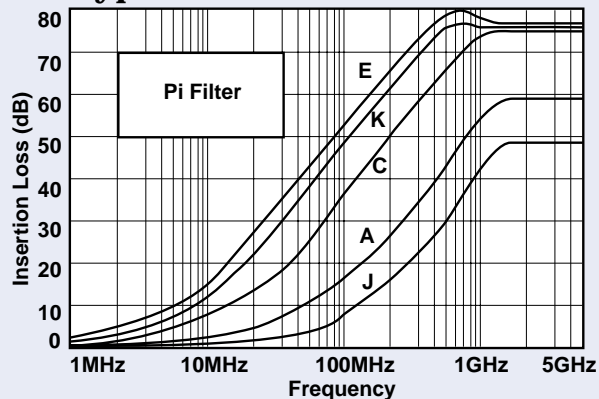

Above curves represent application of proper grounding fundamentals, for assistance consult with Spectrum Control.

Insertion loss measured per MIL-STD-220, no load, 50ohm source and load.

## Electrical Specifications: High Performance Connectors

Filter Designations	Filter Circuits	Capacitance		3 dB Cut-off Frequency Max. (MHz)	Dielectric With-standing Voltage	Working Voltage DC -55°C to +125°C	Minimum Insertion Loss - Decibels (dB)									
		Value	Tol.				5 MHz	10 MHz	20 MHz	50 MHz	100 MHz	200 MHz	500 MHz	1 GHz	2 GHz	5 GHz
J	Pi	100 pF	+100 -0%	32	300V	100V	—	—	—	2	6	11	27	40	43	40
A		310 pF	±20%	17	300V	100V	—	—	3	7	13	21	36	43	50	45
C		1000 pF	+100 -0%	3.2	300V	100V	—	5	9	19	30	43	62	70	68	63
K		2500 pF	+100 -0%	1.3	150V	50V	8	13	18	33	45	58	73	78	70	65
E		4000 pF	+100 -0%	0.8	150V	50V	8	13	20	35	48	61	76	80	70	65
N	C	375 pF	±20%	14	600V	200V	—	—	2	7	13	20	29	35	30	29
L		500 pF	±20%	10.6	600V	200V	—	—	3	10	15	22	31	37	33	31
F		830 pF	±20%	6.4	600V	200V	—	4	9	16	22	28	35	39	38	36
B		1000 pF	+100 -0%	3.2	600V	200V	—	5	10	17	23	30	37	43	44	42
D		5000 pF	+100 -0%	0.64	300V	100V	10	16	22	30	35	41	50	52	52	50

Filter designation "G" for grounded contacts, "I" for insulated (not filtered) contacts. Filter designation "O" for omitted contact and no hole in ground plane.

Above data represents guaranteed minimum.

# Series 700 Specifications and Connector Ordering

## Mechanical Specifications

<i>Shell</i> . . . . .	Zinc diecast, nickel plated 150 $\mu$ inches (3.81 $\mu$ m) min.
<i>Insulators</i> . . . . .	Glass-filled polyester, flammability UL94V-0
<i>Pin Contacts</i> . . . . .	Copper alloy, 15 $\mu$ inches (0.38 $\mu$ m) gold plated * over nickel
<i>Socket Contacts</i> . . . . .	Copper alloy, 30 $\mu$ inches (0.76 $\mu$ m) gold plated * over nickel  * Heavier gold plating available upon request. See pg. 169: Connector Options
<i>Terminations</i> . . . . .	Gold flash for PCB mount and solder cups. Solder dipped also available.
<i>Ground Plane</i> . . . . .	Brass, solder plated
<i>Grounding Springs</i> . . . . .	Beryllium copper, tin plated per MIL-T-10727
<i>Operating Temperature</i> . . . . .	-55°C to +125°C
<i>Capacitors</i> . . . . .	Proprietary barium titanate ceramic formulations

## Electrical Specifications

<i>Current Rating</i> . . . . .	5 Amps
<i>R.F. Current Rating</i> . . . . .	0.3 Amps
<i>Contact Resistance</i> . . . . .	10 milliohms maximum
<i>UL Recognized</i> . . . . .	Under category of commun- ication circuit accessories, File #E149046

**Note:**  
For additional mechanical, electrical, and  
environmental specifications, refer to page 195.

## Ordering Your Connector

### STEP 1: SELECTING THE FILTER

- Using the insert loss graphs on page 146 determine which filters provide the required attenuation at the troublesome frequency, while not affecting the signal frequency by more than 3 to 6 dB.
- Choose the filter type, either feed-thru capacitor or Pi. The Pi is generally considered better due to its superior high frequency performance and steeper curve. The feed-thru capacitor is lower cost.
- Select capacitance value.
- Note the Spectrum letter designation for the filter chosen from the table on page 146.

### STEP 2: SELECTING THE CONNECTOR

- Turn to the appropriate size section. (9, 15, 25, 37, 50)
- Choose either pin contacts (plug) or socket contacts (receptacle).
- Choose the required termination type.
- From the table on the appropriate connector page, using the filter letter designation chosen in step 1 above, select the part number.

### STEP 3: SPECIFYING OPTIONS

- Refer to page 169 for special options including heavy gold plating, 4-40 mounting threads, grounding brackets, hardware, and others.
- Most options are available within the standard lead times.
- Some options require a part number suffix, while other combinations may require factory assistance for part number assignment. If a suffix is shown, add it to your selected part number. If more than one option is needed, consult with factory for part number assignment.

# 9 Series 700 Pin Contact

Shell Size



## Printed Circuit Board Mount

Spectrum Part Number	EMI Filter	
	Filter Designation**	Cap. Value
56-701-001	A	310 pF Pi
56-701-002	B	1000 pF C
56-701-003	C	1000 pF Pi
56-701-004	D	5000 pF C
56-701-005	E	4000 pF Pi
56-701-028	F	830 pF C
56-701-029	J	100 pF Pi
56-701-030	K	2500 pF Pi
56-701-047	N	375 pF C
56-701-086	L	500 pF C

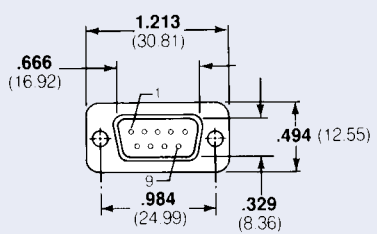

**Mating Face**

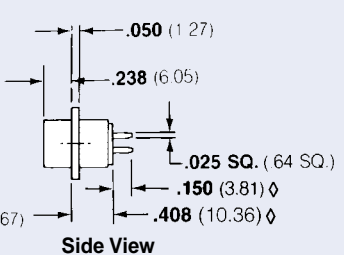

**Side View**

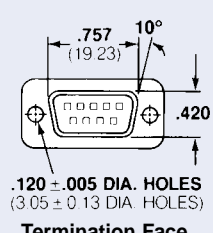

**Termination Face**

## Printed Circuit Board Right Angle Mount

Spectrum Part Number	EMI Filter	
	Filter Designation**	Cap. Value
* 56-702-001	A	310 pF Pi
56-702-002	B	1000 pF C
* 56-702-003	C	1000 pF Pi
56-702-004	D	5000 pF C
* 56-702-005	E	4000 pF Pi
56-702-007	F	830 pF C
56-702-008	J	100 pF Pi
56-702-009	K	2500 pF Pi
56-702-013	N	375 pF C
* 56-702-033	L	500 pF C

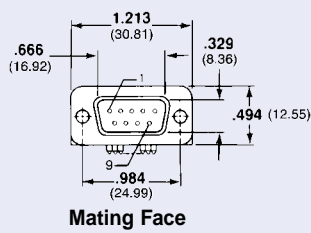

**Mating Face**

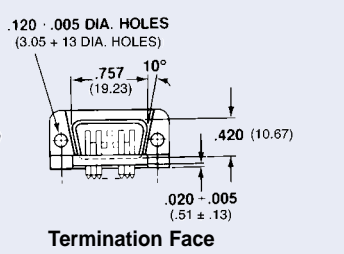

**Termination Face**

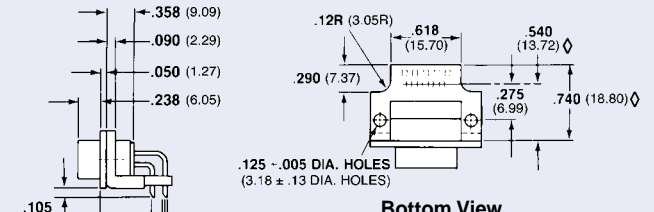

**Bottom View**

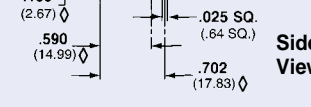

**Side View**

\* May be available from distributor stock.

\*\* See page 146 for filter performance.

Standard Tolerance = ±.005 except where noted, ◇ = ±.015

Dimensions in inches (mm)



**Solderless Wire Wrap**

Spectrum Part Number <i>Select one</i>	EMI Filter		Filter Desig.**	Cap. Value
	L .500	L .375		
56-701 -006	-022	-017	A	310 pF Pi
56-701 -007	-023	-018	B	1000 pF C
56-701 -008	-024	-019	C	1000 pF Pi
56-701 -009	-025	-020	D	5000 pF C
56-701 -010	-026	-021	E	4000 pF Pi
56-701 -037	-034	-031	F	830 pF C
56-701 -038	-035	-032	J	100 pF Pi
56-701 -039	-036	-033	K	2500 pF Pi
56-701 -050	-049	-048	N	375 pF C

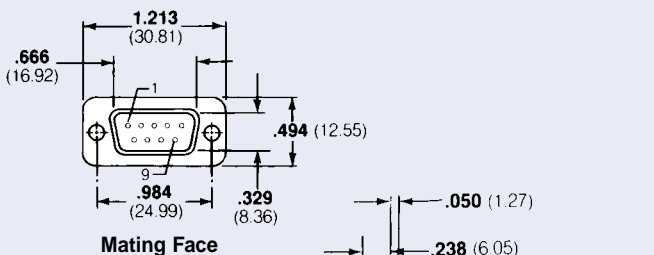
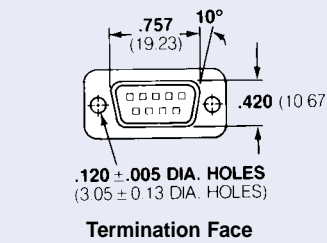
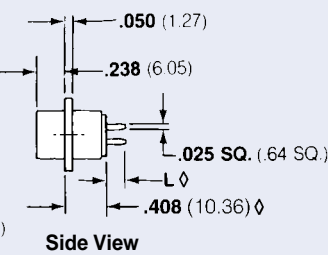
**Solder Cup Termination**

Spectrum Part Number	EMI Filter	
	Filter Designation**	Cap. Value
* 56-701-011	A	310 pF Pi
* 56-701-012	B	1000 pF C
* 56-701-013	C	1000 pF Pi
* 56-701-014	D	5000 pF C
* 56-701-015	E	4000 pF Pi
* 56-701-040	F	830 pF C
56-701-041	J	100 pF Pi
56-701-042	K	2500 pF Pi
56-701-081	N	375 pF C
56-701-087	L	500 pF C

\* May be available from distributor stock.  
 \*\* See page 146 for filter performance.  
 Standard Tolerance = ±.005 except where noted,  $\diamond$  = ±.015

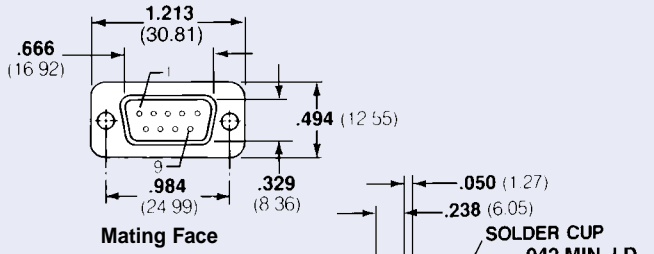
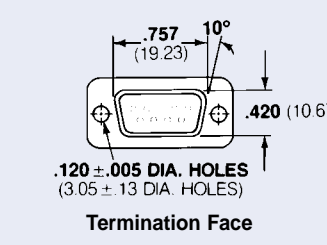
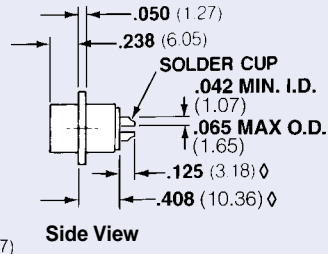
Dimensions in inches (mm)



### Printed Circuit Board Mount

Spectrum Part Number	EMI Filter	
	Filter Designation**	Cap. Value
56-703-001	A	310 pF Pi
56-703-002	B	1000 pF C
56-703-003	C	1000 pF Pi
56-703-004	D	5000 pF C
56-703-005	E	4000 pF Pi
56-703-022	F	830 pF C
56-703-023	J	100 pF Pi
56-703-024	K	2500 pF Pi
56-703-036	N	375 pF C
56-703-047	L	500 pF C

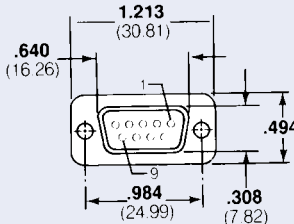
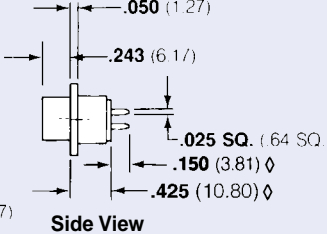

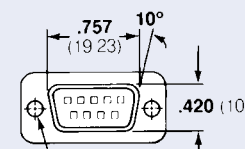
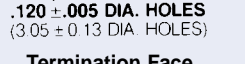

### Printed Circuit Board Right Angle Mount

Spectrum Part Number	EMI Filter	
	Filter Designation**	Cap. Value
56-704-001	A	310 pF Pi
56-704-002	B	1000 pF C
* 56-704-003	C	1000 pF Pi
56-704-004	D	5000 pF C
* 56-704-005	E	4000 pF Pi
56-704-007	F	830 pF C
56-704-008	J	100 pF Pi
56-704-009	K	2500 pF Pi
56-704-018	N	375 pF C
56-704-035	L	500 pF C

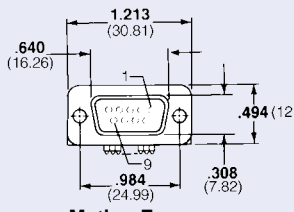
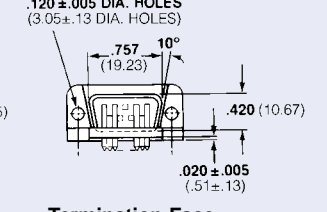
\* May be available from distributor stock.

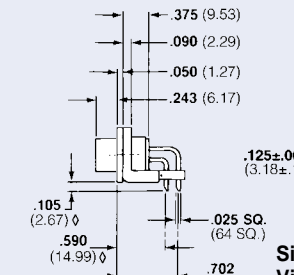
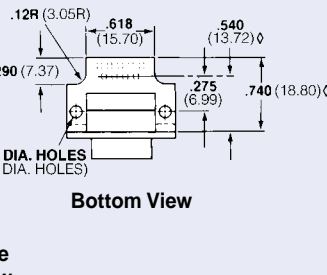
\*\* See page 146 for filter performance.

Standard Tolerance = ±.005 except where noted, ∅ = ±.015

Dimensions in inches (mm)

## Series 700 Socket Contact & Pin/Socket Adapter



### Solderless Wire Wrap

Spectrum Part Number <i>Select one</i>	EMI Filter				
	L .500	L .375	L .250	Filter Desig.**	Cap. Value
56-703-006	-016	-011		A	310 pF Pi
56-703-007	-017	-012		B	1000 pF C
56-703-008	-018	-013		C	1000 pF Pi
56-703-009	-019	-014		D	5000 pF C
* 56-703-010	-020	* -015		E	4000 pF Pi
56-703-031	-028	-025		F	830 pF C
56-703-032	-029	-026		J	100 pF Pi
56-703-033	-030	-027		K	2500 pF Pi
56-703-039	-038	-037		N	375 pF C

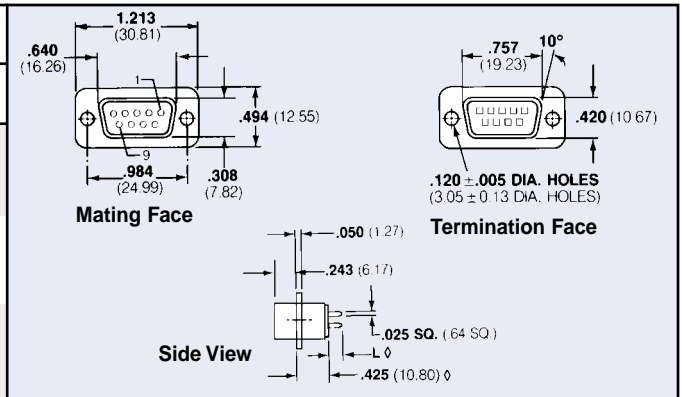

### Solder Cup Termination

Spectrum Part Number	EMI Filter	
	Filter Designation**	Cap. Value
* 56-706-001	A	310 pF Pi
56-706-002	B	1000 pF C
* 56-706-003	C	1000 pF Pi
56-706-004	D	5000 pF C
* 56-706-005	E	4000 pF Pi
56-706-006	F	830 pF C
56-706-007	J	100 pF Pi
* 56-706-008	K	2500 pF Pi
56-706-009	N	375 pF C
56-706-017	L	500 pF C

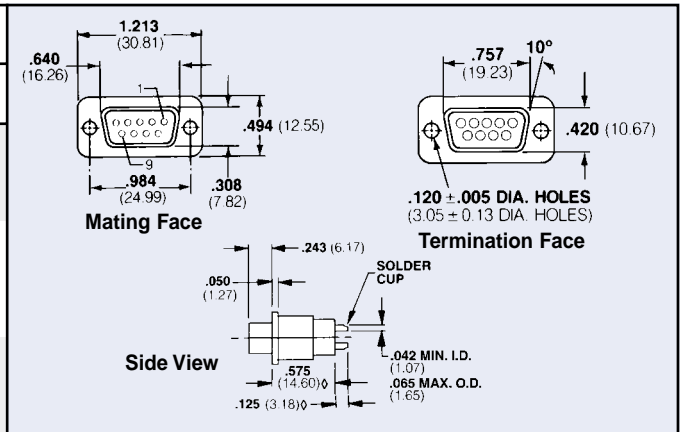

### Pin/Socket Adapter

Spectrum Part Number	EMI Filter	
	Filter Designation**	Cap. Value
* 56-705-001	A	310 pF Pi
56-705-002	B	1000 pF C
* 56-705-003 €	C	1000 pF Pi
56-705-004	D	5000 pF C
* 56-705-005 €	E	4000 pF Pi
* 56-705-008	F	830 pF C
56-705-009	J	100 pF Pi
56-705-010	K	2500 pF Pi
56-705-026	N	375 pF C
56-705-049	L	500 pF C

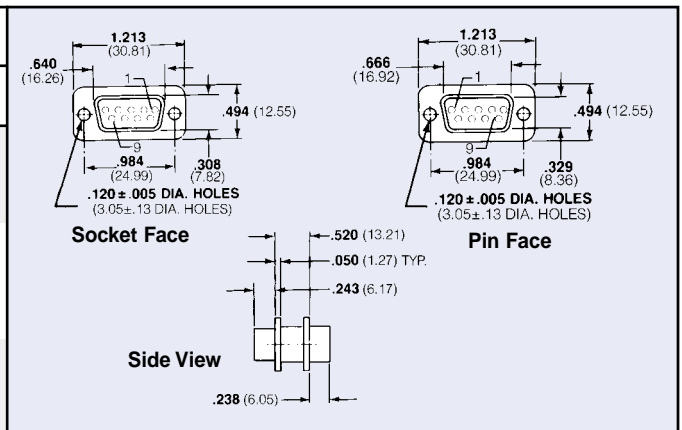

€ Also available through Spectrum Control's authorized European distributors/agents.

\* May be available from distributor stock.

\*\* See page 146 for filter performance.

Standard Tolerance = ±.005 except where noted, ∅ = ±.015

# 15 Series 700 Pin Contact

Shell Size



## Printed Circuit Board Mount

Spectrum Part Number	EMI Filter	
	Filter Designation**	Cap. Value
56-711-001	A	310 pF Pi
56-711-002	B	1000 pF C
56-711-003	C	1000 pF Pi
56-711-004	D	5000 pF C
56-711-005	E	4000 pF Pi
56-711-028	F	830 pF C
56-711-029	J	100 pF Pi
56-711-030	K	2500 pF Pi
56-711-048	N	375 pF C
56-711-088	L	500 pF C

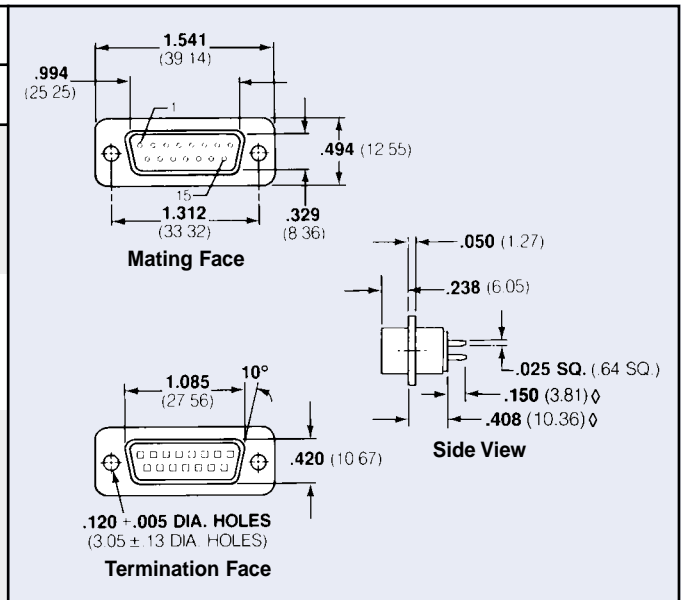

## Printed Circuit Board Right Angle Mount

Spectrum Part Number	EMI Filter	
	Filter Designation**	Cap. Value
* 56-712-001	A	310 pF Pi
56-712-002	B	1000 pF C
* 56-712-003	C	1000 pF Pi
56-712-004	D	5000 pF C
* 56-712-005	E	4000 pF Pi
* 56-712-007	F	830 pF C
56-712-008	J	100 pF Pi
56-712-009	K	2500 pF Pi
56-712-017	N	375 pF C
56-712-039	L	500 pF C

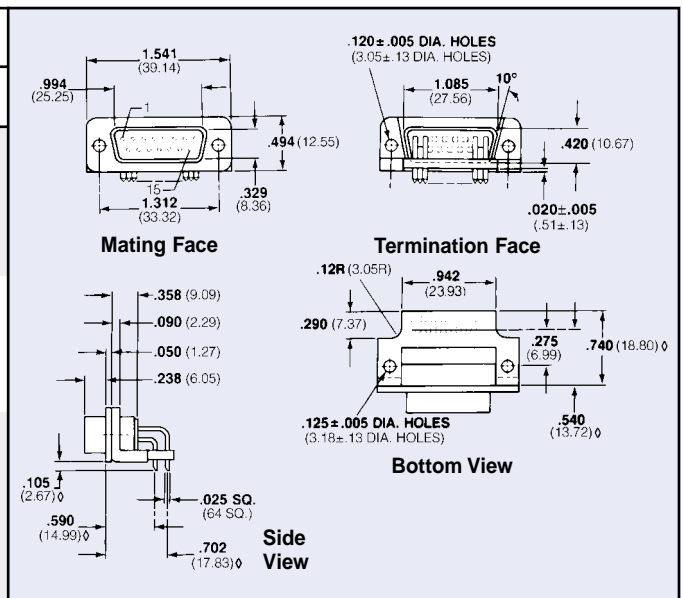

\* May be available from distributor stock.

\*\* See page 146 for filter performance.

Standard Tolerance = ±.005 except where noted, ∅ = ±.015

Dimensions in inches (mm)

# 15 Series 700 Pin Contact

Shell Size



## Solderless Wire Wrap

Spectrum Part Number <i>Select one</i>	EMI Filter		Filter Desig.**	Cap. Value
	L .500	L .375		
56-711 -006 -023 -018			A	310 pF Pi
56-711 -007 -024 -019			B	1000 pF C
56-711 -008 -025 -020			C	1000 pF Pi
56-711 -009 -026 -021			D	5000 pF C
56-711 -010 -027 -022			E	4000 pF Pi
56-711 -037 -034 -031			F	830 pF C
56-711 -038 -035 -032			J	100 pF Pi
56-711 -039 -036 -033			K	2500 pF Pi
56-711 -051 -050 -049			N	375 pF C

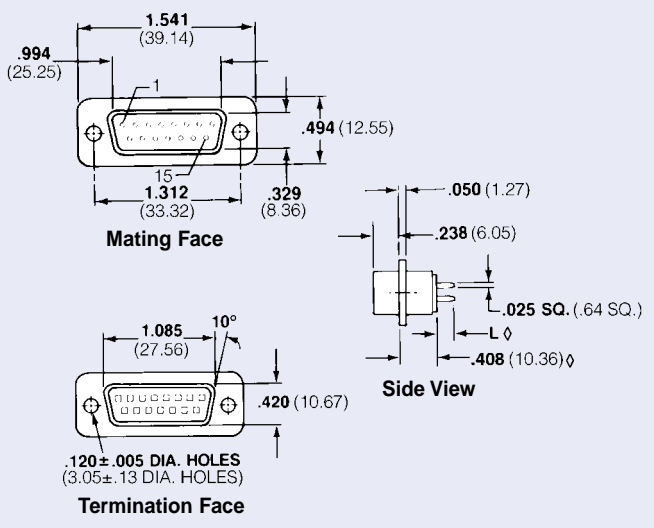

## Solder Cup Termination

Spectrum Part Number	EMI Filter	
	Filter Designation**	Cap. Value
* 56-711-011	A	310 pF Pi
56-711-012	B	1000 pF C
* 56-711-013	C	1000 pF Pi
56-711-014	D	5000 pF C
* 56-711-015	E	4000 pF Pi
* 56-711-040	F	830 pF C
56-711-041	J	100 pF Pi
56-711-042	K	2500 pF Pi
56-711-085	N	375 pF C
56-711-086	L	500 pF C

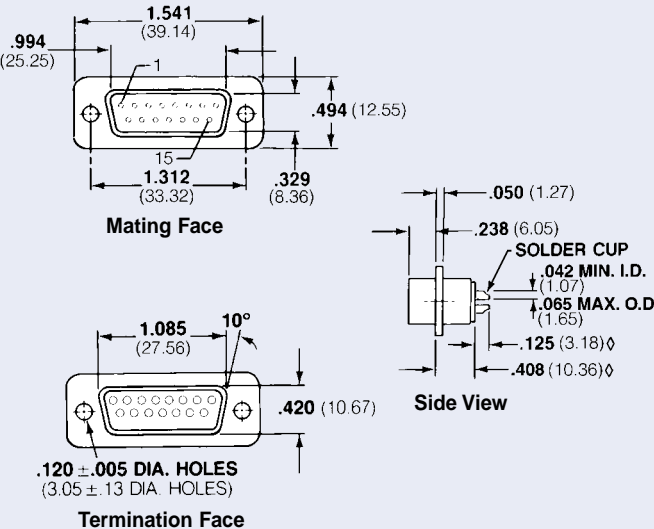

\* May be available from distributor stock.

\*\* See page 146 for filter performance.

Standard Tolerance = ±.005 except where noted, ∅ = ±.015

Dimensions in inches (mm)

# 15 Series 700 Socket Contact

Shell Size



## Printed Circuit Board Mount

Spectrum Part Number	EMI Filter	
	Filter Designation**	Cap. Value
56-713-001	A	310 pF Pi
56-713-002	B	1000 pF C
56-713-003	C	1000 pF Pi
56-713-004	D	5000 pF C
56-713-005	E	4000 pF Pi
56-713-021	F	830 pF C
56-713-022	J	100 pF Pi
56-713-023	K	2500 pF Pi
56-713-037	N	375 pF C
56-713-045	L	500 pF C

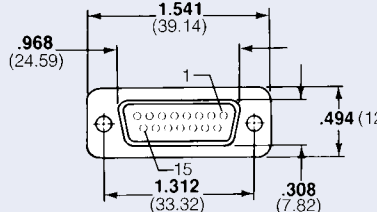
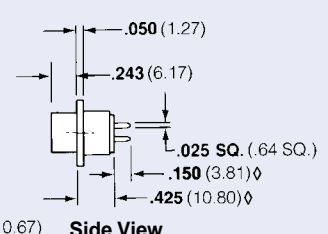
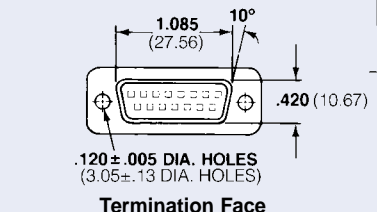
## Printed Circuit Board Right Angle Mount

Spectrum Part Number	EMI Filter	
	Filter Designation**	Cap. Value
* 56-714-001	A	310 pF Pi
56-714-002	B	1000 pF C
* 56-714-003	C	1000 pF Pi
56-714-004	D	5000 pF C
* 56-714-005	E	4000 pF Pi
* 56-714-006	F	830 pF C
56-714-007	J	100 pF Pi
56-714-008	K	2500 pF Pi
56-714-017	N	375 pF C
56-714-031	L	500 pF C

\* May be available from distributor stock.

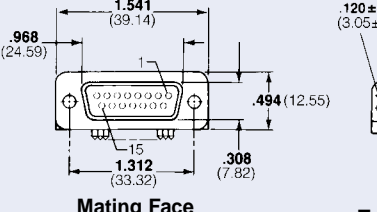
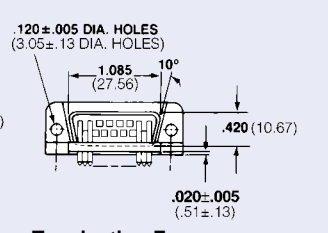
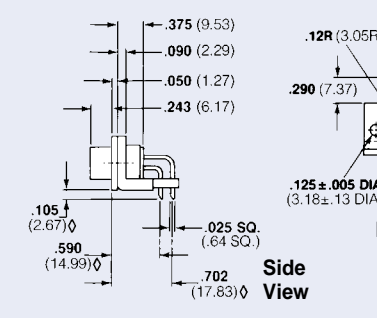
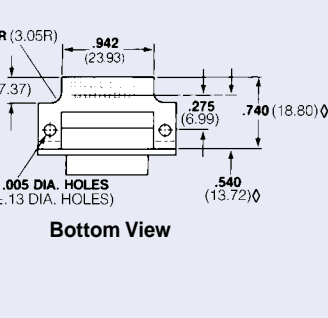
\*\* See page 146 for filter performance.

Standard Tolerance = ±.005 except where noted, ◇ = ±.015

Dimensions in inches (mm)

# 15 Series 700 Shell Size Socket Contact & Pin/Socket Adapter



## Solderless Wire Wrap

Spectrum Part Number <i>Select one</i>	EMI Filter			
	L .500	L .375	L .250	Filter Desig.** / Cap. Value
56-713 -006	-016	-011	A	310 pF Pi
56-713 -007	-017	-012	B	1000 pF C
56-713 -008	-018	-013	C	1000 pF Pi
56-713 -009	-019	-014	D	5000 pF C
56-713 -010	-020	-015	E	4000 pF Pi
56-713 -030	-027	-024	F	830 pF C
56-713 -031	-028	-025	J	100 pF Pi
56-713 -032	-029	-026	K	2500 pF Pi
56-713 -040	-039	-038	N	375 pF C

## Solder Cup Termination

Spectrum Part Number	EMI Filter	
	Filter Designation**	Cap. Value
* 56-716-001	A	310 pF Pi
56-716-002	B	1000 pF C
* 56-716-003	C	1000 pF Pi
56-716-004	D	5000 pF C
* 56-716-005	E	4000 pF Pi
56-716-006	F	830 pF C
56-716-007	J	100 pF Pi
* 56-716-008	K	2500 pF Pi
56-716-009	N	375 pF C
56-716-013	L	500 pF C

## Pin/Socket Adapter

Spectrum Part Number	EMI Filter	
	Filter Designation**	Cap. Value
* 56-715-001	A	310 pF Pi
56-715-002	B	1000 pF C
* 56-715-003 €	C	1000 pF Pi
56-715-004	D	5000 pF C
* 56-715-005 €	E	4000 pF Pi
56-715-007	F	830 pF C
56-715-008	J	100 pF Pi
56-715-009	K	2500 pF Pi
56-715-015	N	375 pF C
56-715-040	L	500 pF C

€ Also available through Spectrum Control's authorized European distributors/agents.

\* May be available from distributor stock.

\*\* See page 146 for filter performance.

Standard Tolerance = ±.005 except where noted, ∅ = ±.015

# 25 Series 700 Pin Contact

Shell Size



## Printed Circuit Board Mount

Spectrum Part Number	EMI Filter	
	Filter Designation**	Cap. Value
56-721-001	A	310 pF Pi
56-721-002	B	1000 pF C
56-721-003	C	1000 pF Pi
56-721-004	D	5000 pF C
56-721-005	E	4000 pF Pi
56-721-033	F	830 pF C
56-721-034	J	100 pF Pi
56-721-035	K	2500 pF Pi
56-721-063	N	375 pF C
56-721-111	L	500 pF C

**Mating Face**

**Termination Face**

**Side View**

## Printed Circuit Board Right Angle Mount

Spectrum Part Number	EMI Filter	
	Filter Designation**	Cap. Value
* 56-722-001	A	310 pF Pi
56-722-002	B	1000 pF C
* 56-722-003	C	1000 pF Pi
56-722-004	D	5000 pF C
* 56-722-005	E	4000 pF Pi
* 56-722-008	F	830 pF C
56-722-009	J	100 pF Pi
56-722-010	K	2500 pF Pi
56-722-027	N	375 pF C
56-722-060	L	500 pF C

**Mating Face**

**Termination Face**

**Bottom View**

**Side View**

\* May be available from distributor stock.

\*\* See page 146 for filter performance.

Standard Tolerance = ±.005 except where noted, ∅ = ±.015

Dimensions in inches (mm)

# 25 Series 700 Pin Contact

Shell Size



## Solderless Wire Wrap

Spectrum Part Number <i>Select one</i>	EMI Filter				
	L .500	L .375	L .250	Filter Desig.**	Cap. Value
56-721 -006 -028 -024				A	310 pF Pi
56-721 -007 -029 -025				B	1000 pF C
56-721 -008 -030 -026				C	1000 pF Pi
56-721 -009 -031 -022				D	5000 pF C
56-721 -010 -032 -027				E	4000 pF Pi
56-721 -042 -039 -036				F	830 pF C
56-721 -043 -040 -037				J	100 pF Pi
56-721 -044 -041 -038				K	2500 pF Pi
56-721 -066 -065 -064				N	375 pF C

**Mating Face**

**Termination Face**

**Side View**

## Solder Cup Termination

Spectrum Part Number	EMI Filter	
	Filter Designation**	Cap. Value
* 56-721-011	A	310 pF Pi
* 56-721-012	B	1000 pF C
* 56-721-013	C	1000 pF Pi
56-721-014	D	5000 pF C
* 56-721-015	E	4000 pF Pi
* 56-721-045	F	830 pF C
56-721-046	J	100 pF Pi
56-721-047	K	2500 pF Pi
56-721-070	N	375 pF C
56-721-112	L	500 pF C

**Mating Face**

**Termination Face**

**Side View**

\* May be available from distributor stock.

\*\* See page 146 for filter performance.

Standard Tolerance = ±.005 except where noted, ∅ = ±.015

Dimensions in inches (mm)

# 25 Series 700 Socket Contact

Shell Size

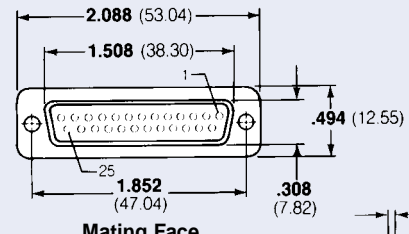
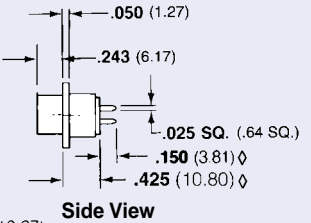
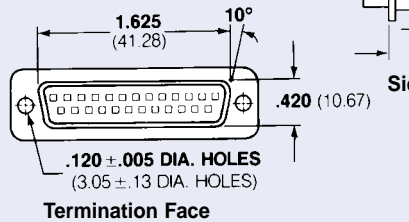
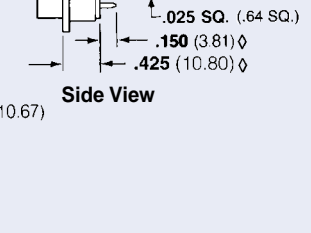

## Printed Circuit Board Mount

Spectrum Part Number	EMI Filter		Mating Face	Side View
	Filter Designation**	Cap. Value		
56-723-001	A	310 pF Pi	 <p>2.088 (53.04) 1.508 (38.30) 1.852 (47.04) .494 (12.55) .308 (7.82)</p>	 <p>.050 (1.27) .243 (6.17) .025 SQ. (.64 SQ.) .150 (3.81) <math>\diamond</math> .425 (10.80) <math>\diamond</math></p>
56-723-002	B	1000 pF C		
56-723-003	C	1000 pF Pi	 <p>1.625 (41.28) 10° .420 (10.67) .120 ± .005 DIA. HOLES (3.05 ± .13 DIA. HOLES)</p>	 <p>.020 ± .005 (51 ± 13) <math>\diamond</math> .275 (6.99) .740 (18.80) <math>\diamond</math> .540 (13.72) <math>\diamond</math> .702 (17.83) <math>\diamond</math> .105 (2.67) <math>\diamond</math> .590 (14.99) <math>\diamond</math></p>
56-723-004	D	5000 pF C		
56-723-005	E	4000 pF Pi	<p><b>Termination Face</b></p>	<p><b>Bottom View</b></p>
56-723-023	F	830 pF C		
56-723-024	J	100 pF Pi	<p><b>Termination Face</b></p>	<p><b>Bottom View</b></p>
56-723-025	K	2500 pF Pi		
56-723-045	N	375 pF C	<p><b>Termination Face</b></p>	<p><b>Bottom View</b></p>
56-723-069	L	500 pF C		

## Printed Circuit Board Right Angle Mount

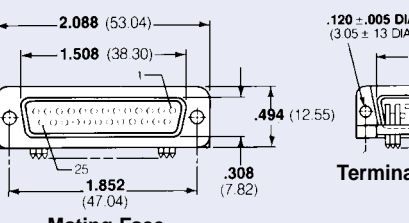
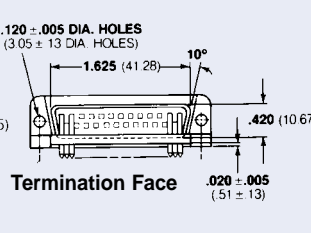
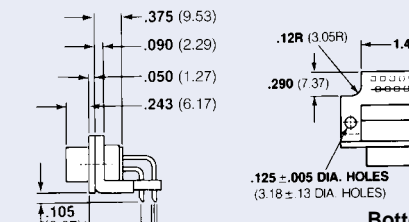
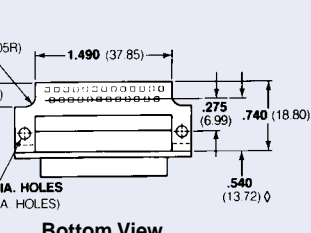
Spectrum Part Number	EMI Filter		Mating Face	Side View
	Filter Designation**	Cap. Value		
* 56-724-001	A	310 pF Pi	 <p>2.088 (53.04) 1.508 (38.30) 1.852 (47.04) .494 (12.55) .308 (7.82)</p>	 <p>.120 ± .005 DIA. HOLES (3.05 ± .13 DIA. HOLES) 1.625 (41.28) 10° .420 (10.67) .020 ± .005 (51 ± 13) <math>\diamond</math></p>
56-724-002	B	1000 pF C		
* 56-724-003	C	1000 pF Pi	 <p>.375 (9.53) .090 (2.29) .050 (1.27) .243 (6.17)</p>	 <p>.12R (3.05R) 1.490 (37.85) .290 (7.37) .275 (6.99) .740 (18.80) <math>\diamond</math> .540 (13.72) <math>\diamond</math> .702 (17.83) <math>\diamond</math> .105 (2.67) <math>\diamond</math> .590 (14.99) <math>\diamond</math></p>
56-724-004	D	5000 pF C		
* 56-724-005	E	4000 pF Pi	<p><b>Termination Face</b></p>	<p><b>Bottom View</b></p>
* 56-724-008	F	830 pF C		
56-724-009	J	100 pF Pi	<p><b>Termination Face</b></p>	<p><b>Bottom View</b></p>
56-724-010	K	2500 pF Pi		
56-724-021	N	375 pF C	<p><b>Termination Face</b></p>	<p><b>Bottom View</b></p>
56-724-046	L	500 pF C		

\* May be available from distributor stock.

\*\* See page 146 for filter performance.

Standard Tolerance = ±.005 except where noted,  $\diamond$  = ±.015

Dimensions in inches (mm)

# 25 Series 700

## Socket Contact & Pin/Socket Adapter

Shell Size



### Solderless Wire Wrap

Spectrum Part Number <i>Select one</i>	EMI Filter			Filter Desig.**	Cap. Value
	L .500	L .375	L .250		
* 56-723 -006 -017 * -012				A	310 pF Pi
56-723 -007 -018 -013				B	1000 pF C
* 56-723 -008 -019 * -014				C	1000 pF Pi
56-723 -009 -020 -015				D	5000 pF C
* 56-723 -010 -021 * -016				E	4000 pF Pi
* 56-723 -032 -029 * -026				F	830 pF C
56-723 -033 -030 -027				J	100 pF Pi
56-723 -034 -031 -028				K	2500 pF Pi
56-723 -048 -047 -046				N	375 pF C

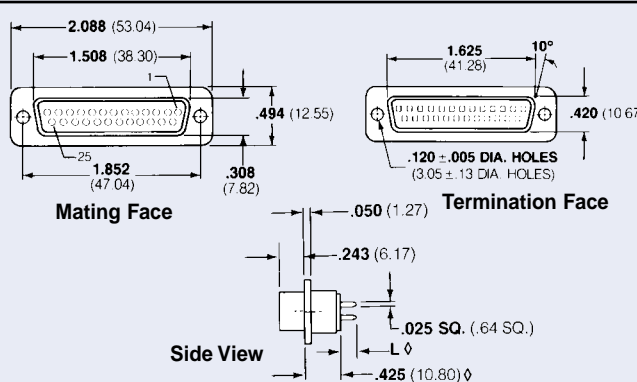

### Solder Cup Termination

Spectrum Part Number	EMI Filter	
	Filter Designation**	Cap. Value
* 56-726-001	A	310 pF Pi
56-726-002	B	1000 pF C
* 56-726-003	C	1000 pF Pi
56-726-004	D	5000 pF C
* 56-726-005	E	4000 pF Pi
56-726-006	F	830 pF C
56-726-007	J	100 pF Pi
* 56-726-008	K	2500 pF Pi
56-726-009	N	375 pF C
56-726-021	L	500 pF C

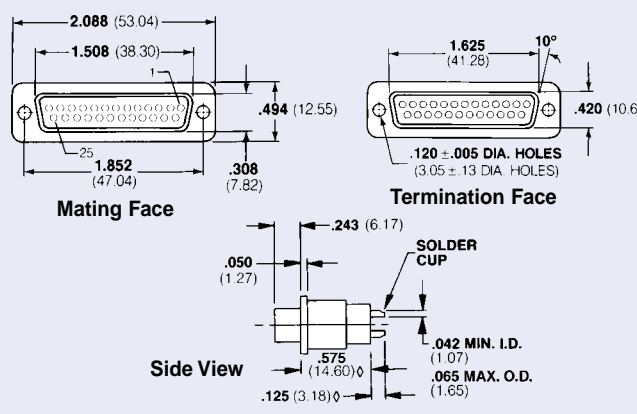

### Pin/Socket Adapter

Spectrum Part Number	EMI Filter	
	Filter Designation**	Cap. Value
* 56-725-001	A	310 pF Pi
56-725-002	B	1000 pF C
* 56-725-003 €	C	1000 pF Pi
56-725-004	D	5000 pF C
* 56-725-005 €	E	4000 pF Pi
* 56-725-019	F	830 pF C
56-725-020	J	100 pF Pi
* 56-725-021	K	2500 pF Pi
56-725-064	N	375 pF C
56-725-073	L	500 pF C

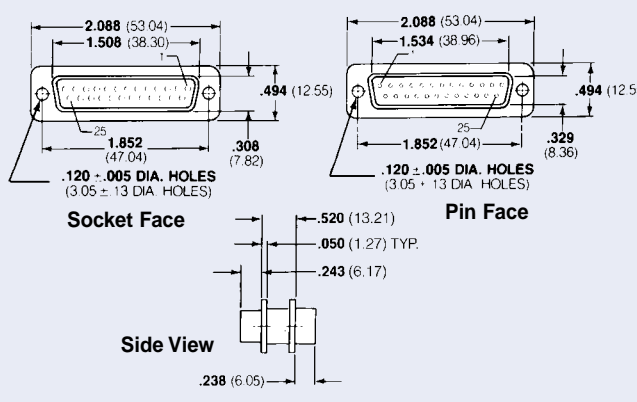

€ Also available through Spectrum Control's authorized European distributors/agents.

\* May be available from distributor stock.

\*\* See page 146 for filter performance.

Standard Tolerance = ±.005 except where noted, ∅ = ±.015

Dimensions in inches (mm)

# 37 Series 700 Pin Contact

Shell Size



## Printed Circuit Board Mount

Spectrum Part Number	EMI Filter	
	Filter Designation**	Cap. Value
56-731-001	A	310 pF Pi
56-731-002	B	1000 pF C
56-731-003	C	1000 pF Pi
56-731-004	D	5000 pF C
56-731-005	E	4000 pF Pi
56-731-028	F	830 pF C
56-731-029	J	100 pF Pi
56-731-030	K	2500 pF Pi
56-731-048	N	375 pF C
56-731-076	L	500 pF C

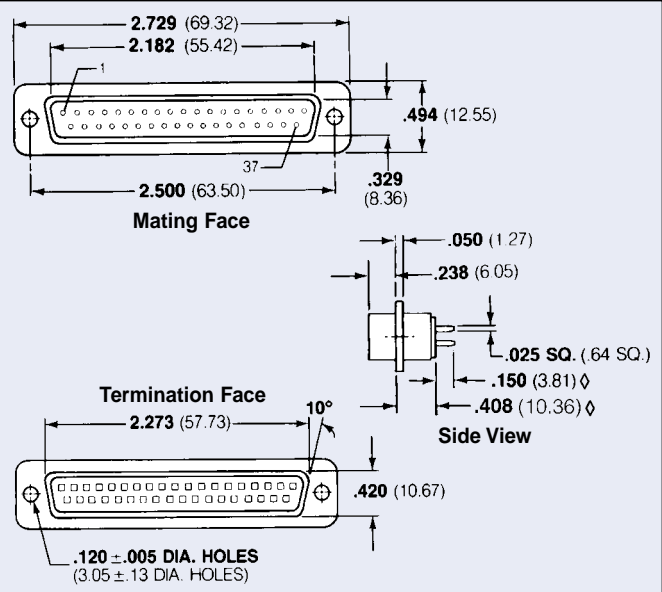

**Mating Face**  
 2.729 (69.32)  
 2.182 (55.42)  
 .494 (12.55)  
 2.500 (63.50)  
 .329 (8.36)  
 37

**Termination Face**  
 2.273 (57.73)  
 10°  
 .420 (10.67)  
 .120 ± .005 DIA. HOLES (3.05 ± .13 DIA. HOLES)

**Side View**  
 .050 (1.27)  
 .238 (6.05)  
 .025 SQ. (.64 SQ.)  
 .150 (3.81) ∅  
 .408 (10.36) ∅

## Printed Circuit Board Right Angle Mount

Spectrum Part Number	EMI Filter	
	Filter Designation**	Cap. Value
56-732-001	A	310 pF Pi
56-732-002	B	1000 pF C
* 56-732-003	C	1000 pF Pi
56-732-004	D	5000 pF C
* 56-732-005	E	4000 pF Pi
56-732-006	F	830 pF C
56-732-007	J	100 pF Pi
56-732-008	K	2500 pF Pi
56-732-009	N	375 pF C
56-732-023	L	500 pF C

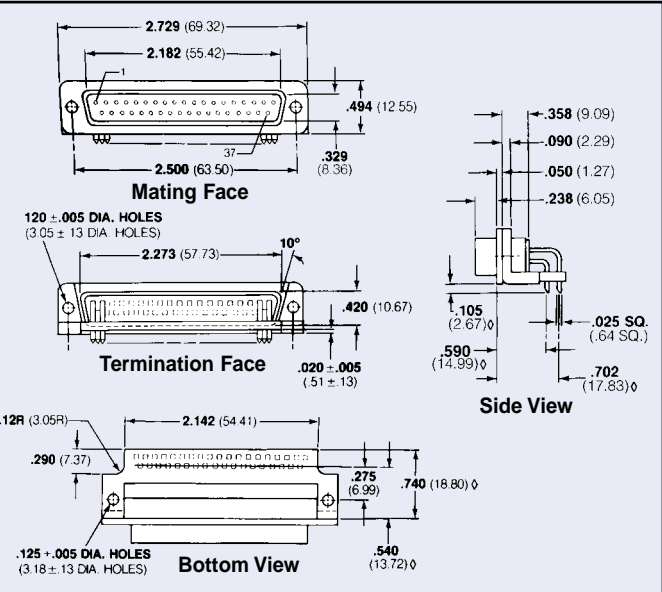

**Mating Face**  
 2.729 (69.32)  
 2.182 (55.42)  
 .494 (12.55)  
 2.500 (63.50)  
 .329 (8.36)  
 37

**Termination Face**  
 2.273 (57.73)  
 10°  
 .420 (10.67)  
 .020 ± .005 (51 ± 13)

**Bottom View**  
 .12R (3.05R)  
 .290 (7.37)  
 2.142 (54.41)  
 .275 (6.99)  
 .740 (18.80) ∅  
 .125 ± .005 DIA. HOLES (3.18 ± .13 DIA. HOLES)  
 .540 (13.72) ∅

**Side View**  
 .358 (9.09)  
 .090 (2.29)  
 .050 (1.27)  
 .238 (6.05)  
 .105 (2.67) ∅  
 .590 (14.99) ∅  
 .025 SQ. (.64 SQ.)  
 .702 (17.83) ∅

\* May be available from distributor stock.

\*\* See page 146 for filter performance.

Standard Tolerance = ±.005 except where noted, ∅ = ±.015

Dimensions in inches (mm)

# 37 Series 700 Pin Contact

Shell Size



## Solderless Wire Wrap

Spectrum Part Number <i>Select one</i>	EMI Filter				
	L .500	L .375	L .250	Filter Desig.**	Cap. Value
56-731 -006 -023 -018				A	310 pF Pi
56-731 -007 -024 -019				B	1000 pF C
56-731 -008 -025 -020				C	1000 pF Pi
56-731 -009 -026 -021				D	5000 pF C
56-731 -010 -027 -022				E	4000 pF Pi
56-731 -037 -034 -031				F	830 pF C
56-731 -038 -035 -032				J	100 pF Pi
56-731 -039 -036 -033				K	2500 pF Pi
56-731 -051 -050 -049				N	375 pF C

## Solder Cup Termination

Spectrum Part Number	EMI Filter	
	Filter Designation**	Cap. Value
* 56-731-011	A	310 pF Pi
56-731-012	B	1000 pF C
* 56-731-013	C	1000 pF Pi
56-731-014	D	5000 pF C
* 56-731-015	E	4000 pF Pi
* 56-731-040	F	830 pF C
56-731-041	J	100 pF Pi
56-731-042	K	2500 pF Pi
56-731-060	N	375 pF C
56-731-077	L	500 pF C

\* May be available from distributor stock.

\*\* See page 146 for filter performance.

Standard Tolerance = ±.005 except where noted, ◊ = ±.015

Dimensions in inches (mm)

# 37 Series 700 Socket Contact

Shell Size



## Printed Circuit Board Mount

Spectrum Part Number	EMI Filter	
	Filter Designation**	Cap. Value
56-733-001	A	310 pF Pi
56-733-002	B	1000 pF C
56-733-003	C	1000 pF Pi
56-733-004	D	5000 pF C
56-733-005	E	4000 pF Pi
56-733-021	F	830 pF C
56-733-022	J	100 pF Pi
56-733-023	K	2500 pF Pi
56-733-035	N	375 pF C
56-733-046	L	500 pF C

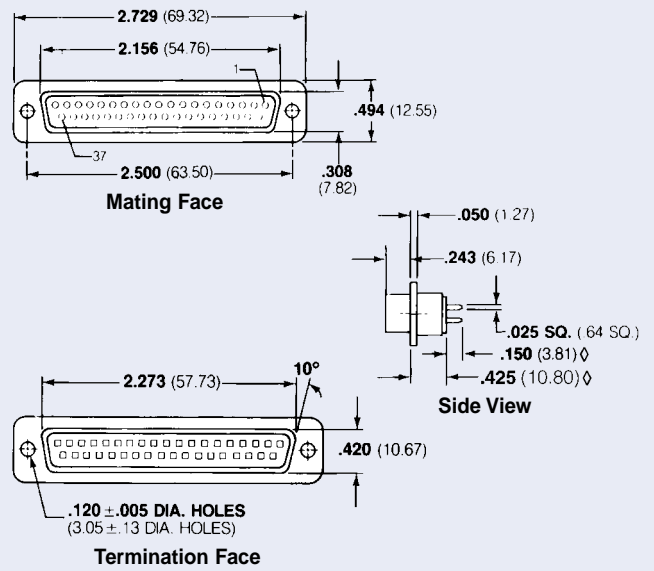

**Mating Face**  
 2.729 (69.32)  
 2.156 (54.76)  
 .494 (12.55)  
 .308 (7.82)  
 2.500 (63.50)  
 .37

**Termination Face**  
 2.273 (57.73)  
 10°  
 .420 (10.67)  
 .120 ± .005 DIA. HOLES (3.05 ± .13 DIA. HOLES)

**Side View**  
 .050 (1.27)  
 .243 (6.17)  
 .025 SQ. (.64 SQ.)  
 .150 (3.81) ∅  
 .425 (10.80) ∅

## Printed Circuit Board Right Angle Mount

Spectrum Part Number	EMI Filter	
	Filter Designation**	Cap. Value
56-734-001	A	310 pF Pi
56-734-002	B	1000 pF C
56-734-003	C	1000 pF Pi
56-734-004	D	5000 pF C
56-734-005	E	4000 pF Pi
56-734-006	F	830 pF C
56-734-007	J	100 pF Pi
56-734-008	K	2500 pF Pi
56-734-012	N	375 pF C
56-734-021	L	500 pF C

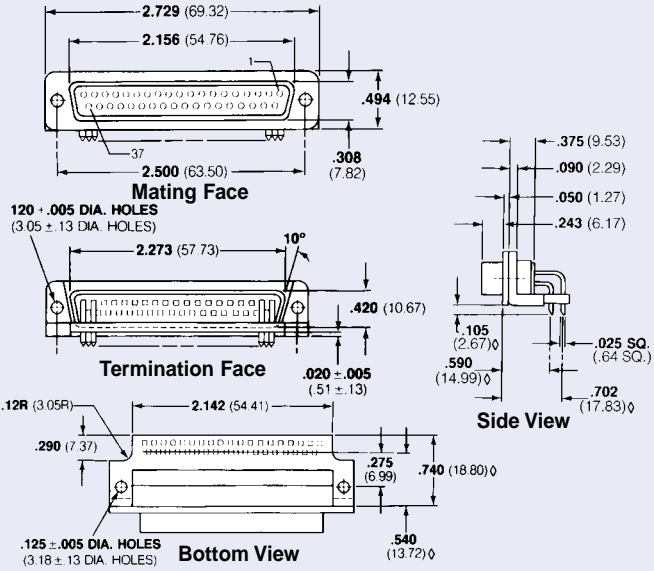

**Mating Face**  
 2.729 (69.32)  
 2.156 (54.76)  
 .494 (12.55)  
 .308 (7.82)  
 2.500 (63.50)  
 .37

**Termination Face**  
 2.273 (57.73)  
 10°  
 .420 (10.67)  
 .020 ± .005 (51 ± 13)

**Bottom View**  
 12R (3.05R)  
 .290 (7.37)  
 2.142 (54.41)  
 .275 (6.99)  
 .740 (18.80)  
 .540 (13.72) ∅  
 .125 ± .005 DIA. HOLES (3.18 ± .13 DIA. HOLES)

**Side View**  
 .375 (9.53)  
 .090 (2.29)  
 .050 (1.27)  
 .243 (6.17)  
 .105 (2.67) ∅  
 .590 (14.99) ∅  
 .025 SQ. (.64 SQ.)  
 .702 (17.83) ∅

\* May be available from distributor stock.

\*\* See page 146 for filter performance.

Standard Tolerance = ±.005 except where noted, ∅ = ±.015

Dimensions in inches (mm)

# 37 Series 700 Socket Contact & Pin/Socket Adapter

Shell Size

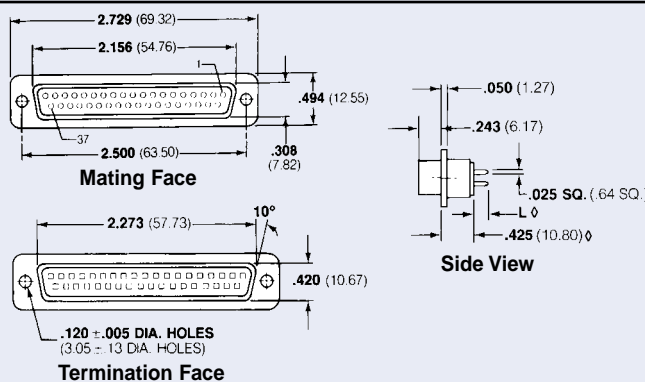
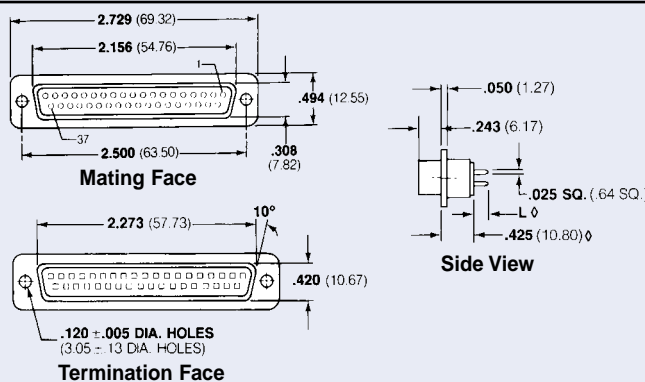

## Solderless Wire Wrap

Spectrum Part Number <i>Select one</i>	EMI Filter			Filter Design.**	Cap. Value	
	L .500	L .375	L .250			
* 56-733 -006	-016	* -011	A	310 pF Pi		
56-733 -007	-017	-012	B	1000 pF C		
56-733 -008	-018	-013	C	1000 pF Pi		
56-733 -009	-019	-014	D	5000 pF C		
56-733 -010	-020	-015	E	4000 pF Pi		
56-733 -030	-027	-024	F	830 pF C		
56-733 -031	-028	-025	J	100 pF Pi		
56-733 -032	-029	-026	K	2500 pF Pi		
56-733 -038	-037	-036	N	375 pF C		

## Solder Cup Termination

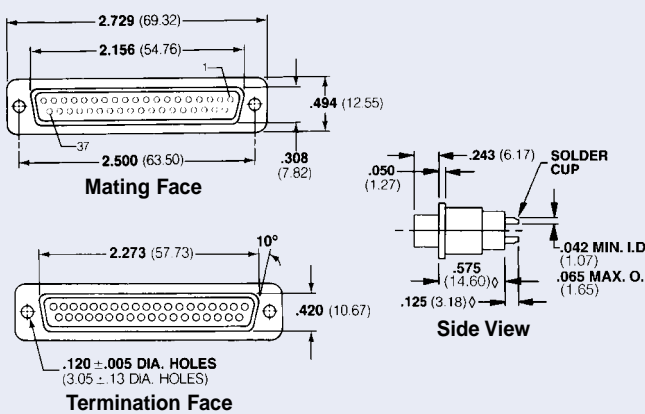
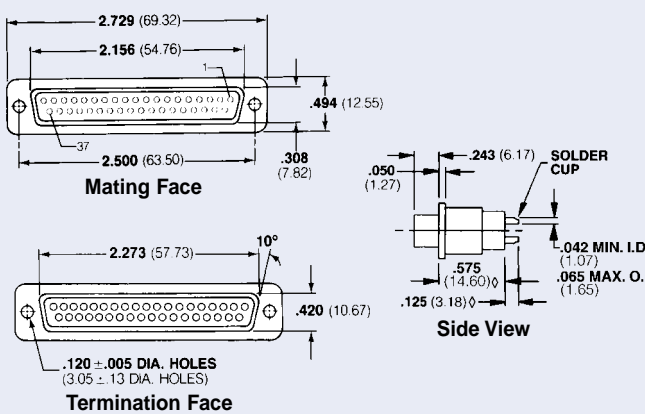
Spectrum Part Number	EMI Filter		
	Filter Designation**	Cap. Value	
* 56-736-001	A	310 pF Pi	
56-736-002	B	1000 pF C	
* 56-736-003	C	1000 pF Pi	
56-736-004	D	5000 pF C	
* 56-736-005	E	4000 pF Pi	
56-736-006	F	830 pF C	
56-736-007	J	100 pF Pi	
* 56-736-008	K	2500 pF Pi	
56-736-009	N	375 pF C	
56-736-015	L	500 pF C	

## Pin/Socket Adapter

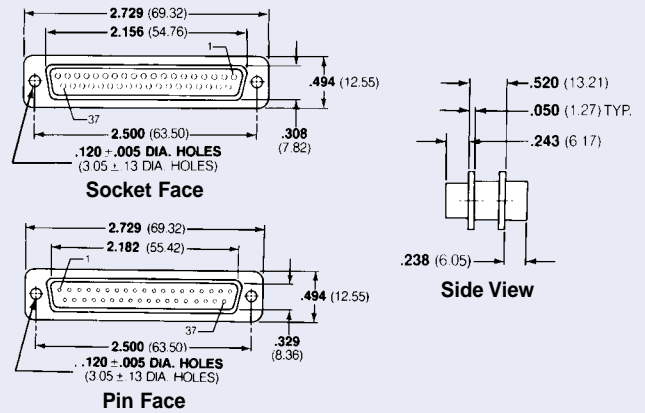
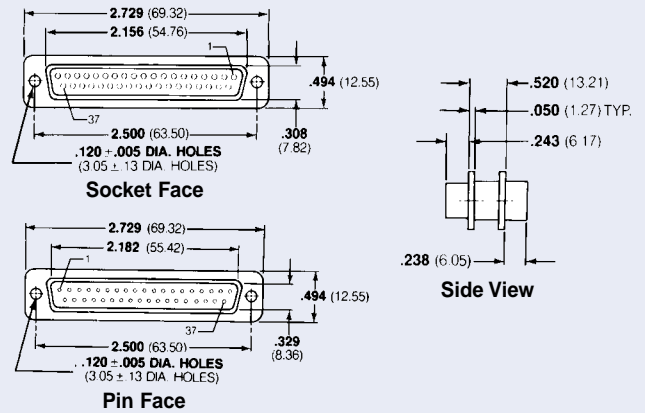
Spectrum Part Number	EMI Filter		
	Filter Designation**	Cap. Value	
* 56-735-001	A	310 pF Pi	
56-735-002	B	1000 pF C	
* 56-735-003 €	C	1000 pF Pi	
56-735-004	D	5000 pF C	
* 56-735-005 €	E	4000 pF Pi	
* 56-735-008	F	830 pF C	
56-735-009	J	100 pF Pi	
56-735-010	K	2500 pF Pi	
56-735-025	N	375 pF C	
56-735-034	L	500 pF C	

€ Also available through Spectrum Control's authorized European distributors/agents.

\* May be available from distributor stock.

\*\* See page 146 for filter performance.

Standard Tolerance = ±.005 except where noted, ∅ = ±.015

Dimensions in inches (mm)

# 50 Series 700 Pin Contact

Shell Size



## Printed Circuit Board Mount

Spectrum Part Number	EMI Filter	
	Filter Designation**	Cap. Value
56-741-001	A	310 pF Pi
56-741-002	B	1000 pF C
56-741-003	C	1000 pF Pi
56-741-004	D	5000 pF C
56-741-005	E	4000 pF Pi
56-741-027	F	830 pF C
56-741-028	J	100 pF Pi
56-741-029	K	2500 pF Pi
56-741-042	N	375 pF C
56-741-066	L	500 pF C

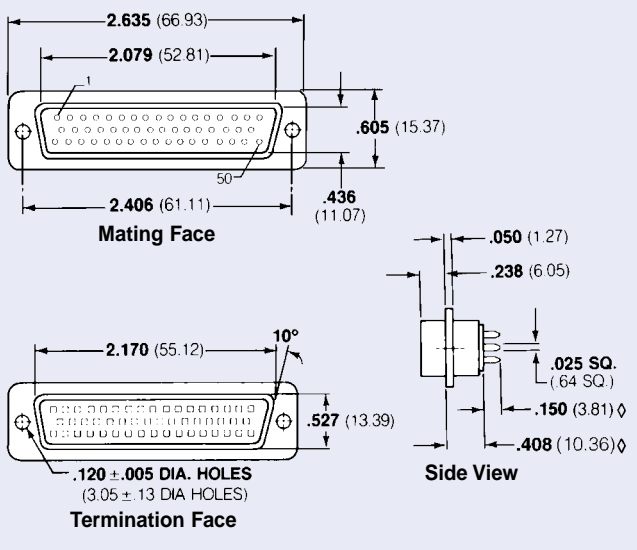

**Mating Face**  
 2.635 (66.93)  
 2.079 (52.81)  
 .605 (15.37)  
 2.406 (61.11)  
 .436 (11.07)

**Termination Face**  
 2.170 (55.12)  
 10°  
 .527 (13.39)  
 .120 ± .005 DIA. HOLES (3.05 ± .13 DIA HOLES)

**Side View**  
 .050 (1.27)  
 .238 (6.05)  
 .025 SQ. (.64 SQ.)  
 .150 (3.81) ∅  
 .408 (10.36) ∅

## Printed Circuit Board Right Angle Mount

Spectrum Part Number	EMI Filter	
	Filter Designation**	Cap. Value
56-742-001	A	310 pF Pi
56-742-002	B	1000 pF C
56-742-003	C	1000 pF Pi
56-742-004	D	5000 pF C
56-742-005	E	4000 pF Pi
56-742-006	F	830 pF C
56-742-007	J	100 pF Pi
56-742-008	K	2500 pF Pi
56-742-009	N	375 pF C
56-742-022	L	500 pF C

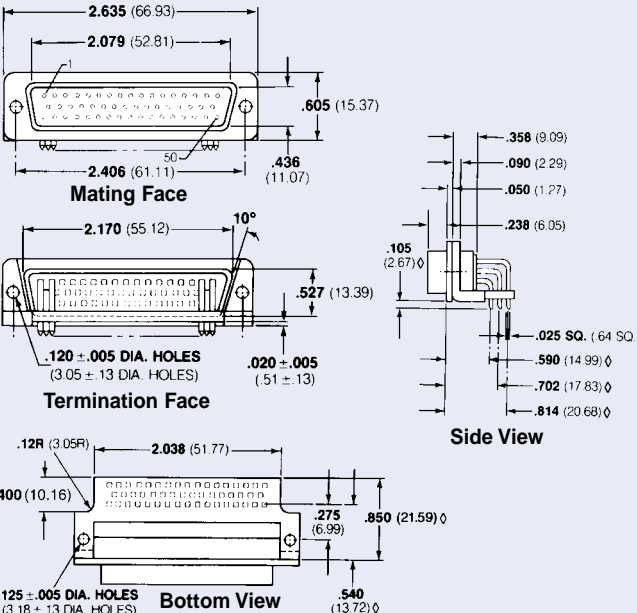

**Mating Face**  
 2.635 (66.93)  
 2.079 (52.81)  
 .605 (15.37)  
 2.406 (61.11)  
 .436 (11.07)

**Termination Face**  
 2.170 (55.12)  
 10°  
 .527 (13.39)  
 .120 ± .005 DIA. HOLES (3.05 ± .13 DIA. HOLES)  
 .020 ± .005 (.51 ± .13)

**Bottom View**  
 .12R (3.05R)  
 2.038 (51.77)  
 .400 (10.16)  
 .275 (6.99)  
 .850 (21.59) ∅  
 .125 ± .005 DIA. HOLES (3.18 ± .13 DIA HOLES)  
 .540 (13.72) ∅

**Side View**  
 .358 (9.09)  
 .090 (2.29)  
 .050 (1.27)  
 .238 (6.05)  
 .105 (2.67) ∅  
 .025 SQ. (.64 SQ.)  
 .590 (14.99) ∅  
 .702 (17.83) ∅  
 .814 (20.68) ∅

\* May be available from distributor stock.

\*\* See page 146 for filter performance.

Standard Tolerance = ±.005 except where noted, ∅ = ±.015

Dimensions in inches (mm)

# 50 Series 700 Pin Contact

Shell Size



## Solderless Wire Wrap

Spectrum Part Number <i>Select one</i>	EMI Filter				
	L .500	L .375	L .250	Filter Desig.**	Cap. Value
56-741 -006 -022 -017				A	310 pF Pi
56-741 -007 -023 -018				B	1000 pF C
56-741 -008 -024 -019				C	1000 pF Pi
56-741 -009 -025 -020				D	5000 pF C
56-741 -010 -026 -021				E	4000 pF Pi
56-741 -036 -033 -030				F	830 pF C
56-741 -037 -034 -031				J	100 pF Pi
56-741 -038 -035 -032				K	2500 pF Pi
56-741 -045 -044 -043				N	375 pF C

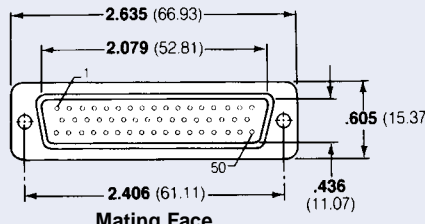
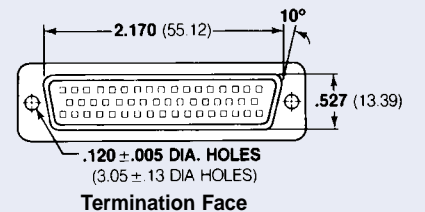
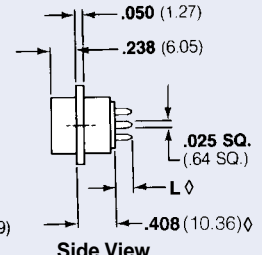
## Solder Cup Termination

Spectrum Part Number	EMI Filter	
	Filter Designation**	Cap. Value
* 56-741-011	A	310 pF Pi
* 56-741-012	B	1000 pF C
* 56-741-013	C	1000 pF Pi
* 56-741-014	D	5000 pF C
* 56-741-015	E	4000 pF Pi
56-741-039	F	830 pF C
56-741-040	J	100 pF Pi
56-741-041	K	2500 pF Pi
56-741-063	N	375 pF C
56-741-067	L	500 pF C

\* May be available from distributor stock.

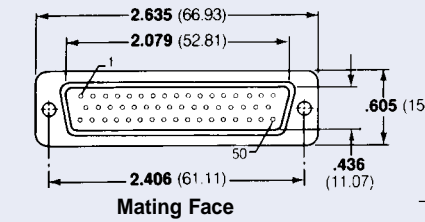
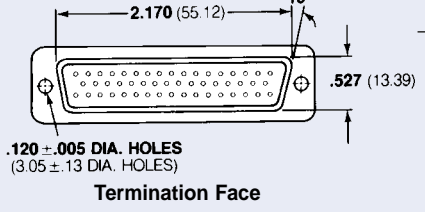
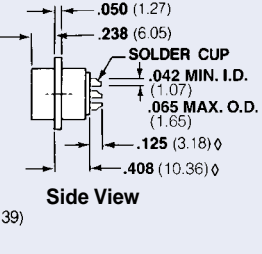
\*\* See page 146 for filter performance.

Standard Tolerance = ±.005 except where noted, ∅ = ±.015

Dimensions in inches (mm)

# 50 Series 700 Socket Contact

Shell Size



## Printed Circuit Board Mount

Spectrum Part Number	EMI Filter		Mating Face	Termination Face	Side View
	Filter Designation**	Cap. Value			
56-743-001	A	310 pF Pi			
56-743-002	B	1000 pF C			
56-743-003	C	1000 pF Pi			
56-743-004	D	5000 pF C			
56-743-005	E	4000 pF Pi			
56-743-021	F	830 pF C			
56-743-022	J	100 pF Pi			
56-743-023	K	2500 pF Pi			
56-743-033	N	375 pF C			
56-743-043	L	500 pF C			

## Printed Circuit Board Right Angle Mount

Spectrum Part Number	EMI Filter		Mating Face	Termination Face	Bottom View	Side View
	Filter Designation**	Cap. Value				
56-744-001	A	310 pF Pi				
56-744-002	B	1000 pF C				
56-744-003	C	1000 pF Pi				
56-744-004	D	5000 pF C				
56-744-005	E	4000 pF Pi				
56-744-006	F	830 pF C				
56-744-007	J	100 pF Pi				
56-744-008	K	2500 pF Pi				
56-744-009	N	375 pF C				
56-744-012	L	500 pF C				

\* May be available from distributor stock.

\*\* See page 146 for filter performance.

Standard Tolerance = ±.005 except where noted, ◊ = ±.015

Dimensions in inches (mm)

# 50 Series 700 Shell Size Socket Contact & Pin/Socket Adapter

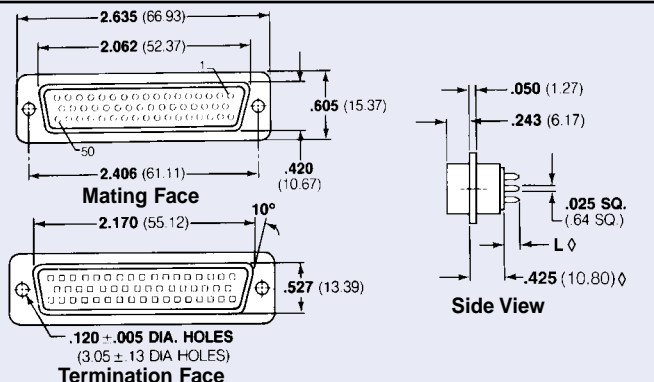

## Solderless Wire Wrap

Spectrum Part Number <i>Select one</i>	EMI Filter			Filter Desig.**	Cap. Value	
	L .500	L .375	L .250			
56-743 -006	-016	-011	A	310 pF Pi		
56-743 -007	-017	-012	B	1000 pF C		
56-743 -008	-018	-013	C	1000 pF Pi		
56-743 -009	-019	-014	D	5000 pF C		
56-743 -010	-020	-015	E	4000 pF Pi		
56-743 -030	-027	-024	F	830 pF C		
56-743 -031	-028	-025	J	100 pF Pi		
56-743 -032	-029	-026	K	2500 pF Pi		
56-743 -036	-035	-034	N	375 pF C		

## Solder Cup Termination

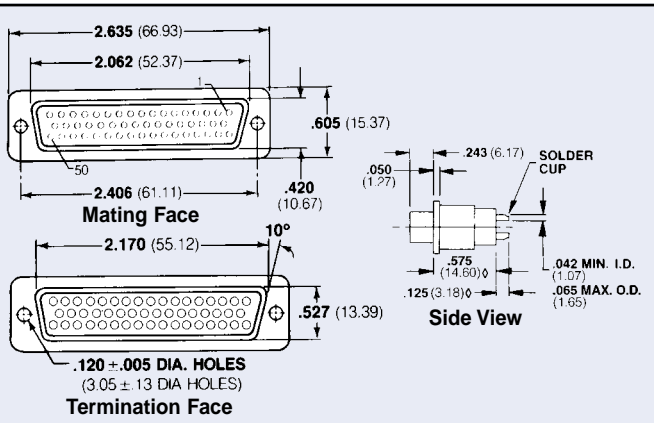
Spectrum Part Number	EMI Filter		
	Filter Designation**	Cap. Value	
56-746-001	A	310 pF Pi	
56-746-002	B	1000 pF C	
56-746-003	C	1000 pF Pi	
56-746-004	D	5000 pF C	
56-746-005	E	4000 pF Pi	
56-746-006	F	830 pF C	
56-746-007	J	100 pF Pi	
56-746-008	K	2500 pF Pi	
56-746-009	N	375 pF C	
56-746-018	L	500 pF C	

## Pin/Socket Adapter

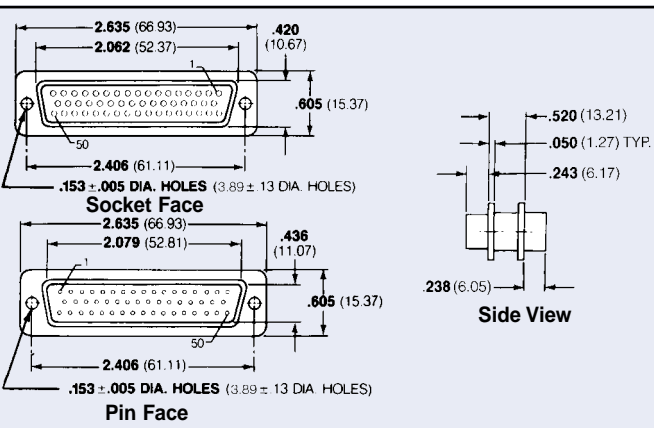
Spectrum Part Number	EMI Filter		
	Filter Designation**	Cap. Value	
* 56-745-001	A	310 pF Pi	
56-745-002	B	1000 pF C	
* 56-745-003	C	1000 pF Pi	
56-745-004	D	5000 pF C	
* 56-745-005	E	4000 pF Pi	
56-745-006	F	830 pF C	
56-745-007	J	100 pF Pi	
56-745-008	K	2500 pF Pi	
56-745-019	N	375 pF C	
56-745-027	L	500 pF C	

\* May be available from distributor stock.

\*\* See page 146 for filter performance.

Standard Tolerance = ±.005 except where noted, ∅ = ±.015

Dimensions in inches (mm)

# D-Subminiature Part Numbering System

## Ordering Information

Example: **56-513-012-TI**

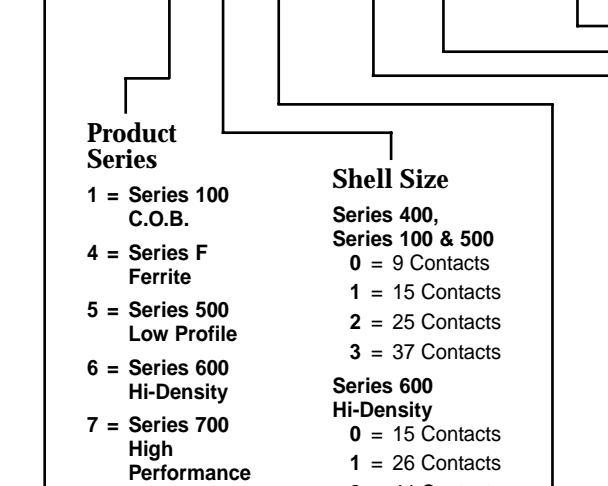
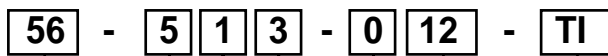

### Filtered D-Subminiature Connectors

#### Product Series

- 1 = Series 100 C.O.B.
- 4 = Series F Ferrite
- 5 = Series 500 Low Profile
- 6 = Series 600 Hi-Density
- 7 = Series 700 High Performance

#### Shell Size

##### Series 400, Series 100 & 500

- 0 = 9 Contacts
- 1 = 15 Contacts
- 2 = 25 Contacts
- 3 = 37 Contacts

##### Series 600 Hi-Density

- 0 = 15 Contacts
- 1 = 26 Contacts
- 2 = 44 Contacts
- 3 = 62 Contacts
- 4 = 78 Contacts

##### Series 700

- 0 = 9 Contacts
- 1 = 15 Contacts
- 2 = 25 Contacts
- 3 = 37 Contacts
- 4 = 50 Contacts

#### Contact Type/Termination

- 1 = Pin to solder cup
- 2 = Pin to 90° PCB mount
- 3 = Socket to straight PCB mount
- 4 = Socket to 90° PCB mount
- 5 = Pin-socket adapter
- 6 = Socket to solder cup
- 7 = Pin to straight PCB mount

Styles available for:

Series 400 only 2, 3, 4, 7

Series 100 1 thru 7

Series 500 only 2, 3, 4 & 7

Series 600 only 1, 2, 3, 4, 5, 7

Series 700 1 thru 7

**Note:** 1 can be Pin to solder cup or Pin to PCB for Series 700. See charts pages 148-167.

#### Line Filtering

- 0 = All positions same
- 9 = Special loading (Series 600 only)

#### Capacitance Value

##### Series 400

- 01 = Always
- Series 100
- 02 = 100 pF
- 03 = 220 pF
- 04 = 470 pF
- 05 = 820 pF
- 06 = 1500 pF
- 07 = 5600 pF
- 08 = 50 pF
- 09 = 180 pF
- 10 = 1000 pF
- 11 = 2200 pF
- 12 = 47 nF

##### Series 500

- 10 = 120 pF
- 11 = 440 pF
- 12 = 840 pF
- 13 = 1000 pF
- 14 = 1500 pF

##### Series 600

- 15 = 85 pF FT
- 16 = 180 pF FT
- 18 = 1000 pF FT
- 19 = 4000 pF FT
- 20 = Insulated contact

##### Series 700

See filter specification chart on page 146 and select part numbers from Series 700 charts pages 148-167.

## Options

See options descriptions on page 169 add suffix ending

### Series 100

- .120 thru-hole and 15μ" gold (.38um)
- 3G - 30μ" gold (.76um)
- 5G - 50μ" gold (1.27um)

#### SC and Straight PCBs

- TIB - 4-40 thread on rear of flange
- TIF - 4-40 thread on front of flange
- MIB - M3 thread on rear of flange
- GBL6 - for .062" boards (1.57mm)
- JS - Jack screws

#### Right Angles and Adapters

- No GBL attached
- GL - includes grounding board lock and 4-40 threads
- T - 4-40 threads
- GB - no board locks
- J - jack screws
- M - M3 thread

### Series F

- HD = Hi-Density (15 socket only)

### Series 500

- TI = 4-40 threads on mounting flange (.125" hole if not selected)
- GBL = Grounded board lock includes 4-40 threads (available only on 90° PCB)
- GBLF = Grounded board lock and ferrite slab provides enhanced LC performance. (Available only on 90° PCB)

### Series 600 Hi-Density

- LI = 4-40 UNC inserts
- S = Solder dipped tails
- 50G = 50 μ (1.27 μm) gold

### Series 700

- LI = 4-40 UNC inserts
- LIM = Metric M3.0 self-locking threads
- GB = Metal bracket provides ground connection, includes 4-40 self-locking threads (for right angle mount only)

- GBL = Grounded board lock (right angle)

- GBL6 = for .062" boards (straight PCB mount) (1.57mm)

- GBL9 = for .093" boards (straight PCB mount) (2.36mm)

- 50G = 50 μ (1.27 μm) gold plating

- S = Solder dipped tails

- JS = Jackscrew mounting

For option combinations, consult factory.

To assist your efforts in selecting the correct Filtered Connector to meet your needs, we have developed a part numbering system. All of the standard products are shown in their respective catalog pages.

Part number **56-513-012-TI** represents a Series 500 connector with 15 contacts in a socket to straight PCB mount configuration. All connector positions have a capacitance value of 840 pF and there are 4-40 threads on mounting flange.

# D-Subminiature Connector Options

## Threaded Inserts

Available on Series 500, 600 & 700

- #4-40 UNC or metric M3.0 threaded inserts in mounting flanges
- Allows ease of panel-assembly
- Plated steel inserts with last thread upset for torque

## Grounding Bracket

For right angle mount PCB connectors, available on Series 700

- Metal bracket in place of plastic
- Provides ground connection direct from circuit board
- Allows shell grounding to board
- Includes 4-40 threads

## Stand-off with Board Lock Feature

For straight PCB connectors, available on Series 700

- Allows shell grounding to board
- Eliminates stress on filter terminations
- Tin plated brass stand-off with snap-in feature
- Available for .062" (1.57mm) or .093" (2.36mm) thick boards

## Grounding Bracket with Board Lock

For right angle mount PCB connectors, available on Series 500 & 700

- Metal bracket provides grounding
- Snap-in, no hardware needed, 4-40 threads included
- For use on .062" (1.57mm) thick boards

## Gold Plating

Available on Series 600 & 700

- High reliability applications, 50µ" (1.27 µm) gold over 50µ" (1.27 µm) nickel

## Solder Dipped Tails

Available on Series 600 & 700 connectors

- Solder dipped tails added to standard gold flash

## Water Block

Consult Spectrum Control engineers for specifics.

- Internally sealed in accordance with NEMA Standard Rain Test

### Threaded Inserts

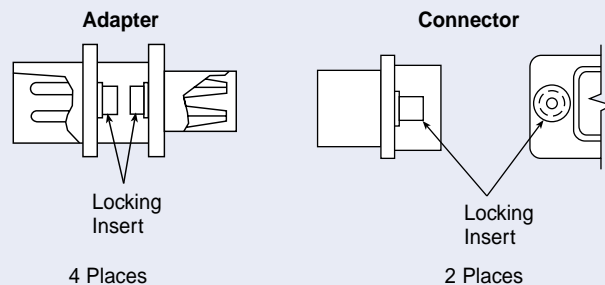

### Grounding Brackets

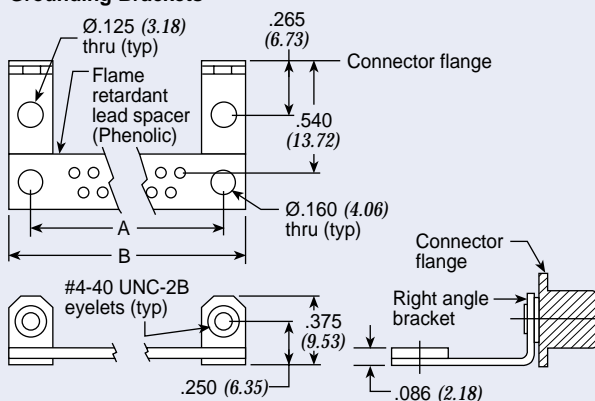

Size	A	B
9	.984 (24.99)	1.214 (30.84)
15	1.312 (33.32)	1.542 (39.17)
25	1.852 (47.04)	2.088 (53.04)
37	2.500 (63.50)	2.730 (69.34)

### Stand-off with Board Lock

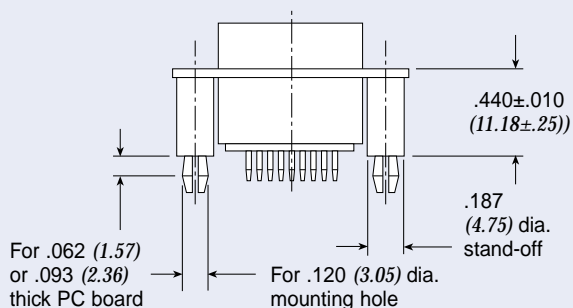

### Grounding Bracket with Board Lock (see above for grounding bracket details)

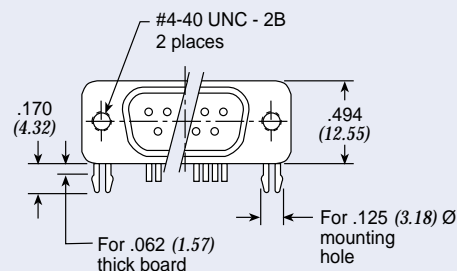

Dimensions in inches (mm)

# Filtered Combo D-Subminiature Connectors



Spectrum's line of filtered combo D-subminiatures provide high insertion loss with tubular capacitive filtering. These connectors are available with 20 Amp power contacts, 40 Amp power contacts, 50 ohm coaxial contacts or 75 ohm coaxial contacts. Configurations include male and female versions with straight PC terminals, right angle PC terminals or solder cup terminals. Standard D-sub shell sizes provide intermateability with unfiltered connectors. High strength epoxy potting protects ceramic elements.

Capacitive filtering is available in 470, 820, 1000 and 1500 pF. Additional capacitance ranges and configurations can be provided upon request. Please consult factory for more information.

## Applications

- Telecommunications base station equipment
- Switching and transmission equipment
- Power supplies
- Industrial equipment
- Computer work stations

## Ordering Information

Example: **563A03W3101GBL9**

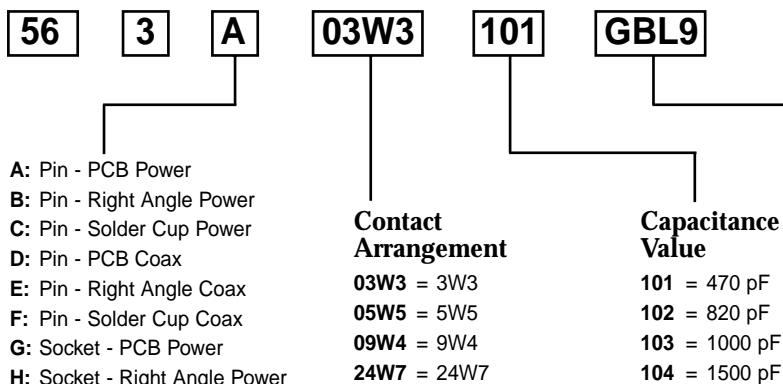

- A: Pin - PCB Power
- B: Pin - Right Angle Power
- C: Pin - Solder Cup Power
- D: Pin - PCB Coax
- E: Pin - Right Angle Coax
- F: Pin - Solder Cup Coax
- G: Socket - PCB Power
- H: Socket - Right Angle Power
- J: Socket - Solder Cup Power
- K: Socket - PCB Coax
- L: Socket - Right Angle Coax
- M: Socket - Solder Cup Coax
- N: Custom Combination

## Mechanical Specifications

- Shell . . . . . Steel, tin plated
- Power Contacts . . . . . Brass, gold plated .000030 in. (.000762 μm) minimum
- Signal Contacts . . . . . Pin: brass, gold plated .000030 in. (.000762 μm) min.  
Socket: copper alloy, gold plated .000030 in. (.000762 μm) min.
- Insulator . . . . . Glass-filled polyester, flammability UL94V-0
- Operating Temperature. . . . -55°C to +125°C
- Capacitors . . . . . Proprietary barium titanate ceramic formulations

## Electrical Specifications

- Operating Voltage . . . . . 200 VDC
- Current Rating\* . . . . . 40 Amp
- Insulation Resistance . . . . . 1 Gohm at 100 VDC
- Capacitance . . . . . 470, 820, 1000, 1500, or 4000 pF (FT only) ±20% (10 - 5000 pF available for signal pins, consult factory for part number on values above 1500 pF and below 470 pF)

- Dielectric Withstanding Voltage. . . . . 600 VDC

\*30 Amp available. Consult factory.

# Filtered Combo D-Subminiature Connectors 3W3

## Plug - Solder Cup

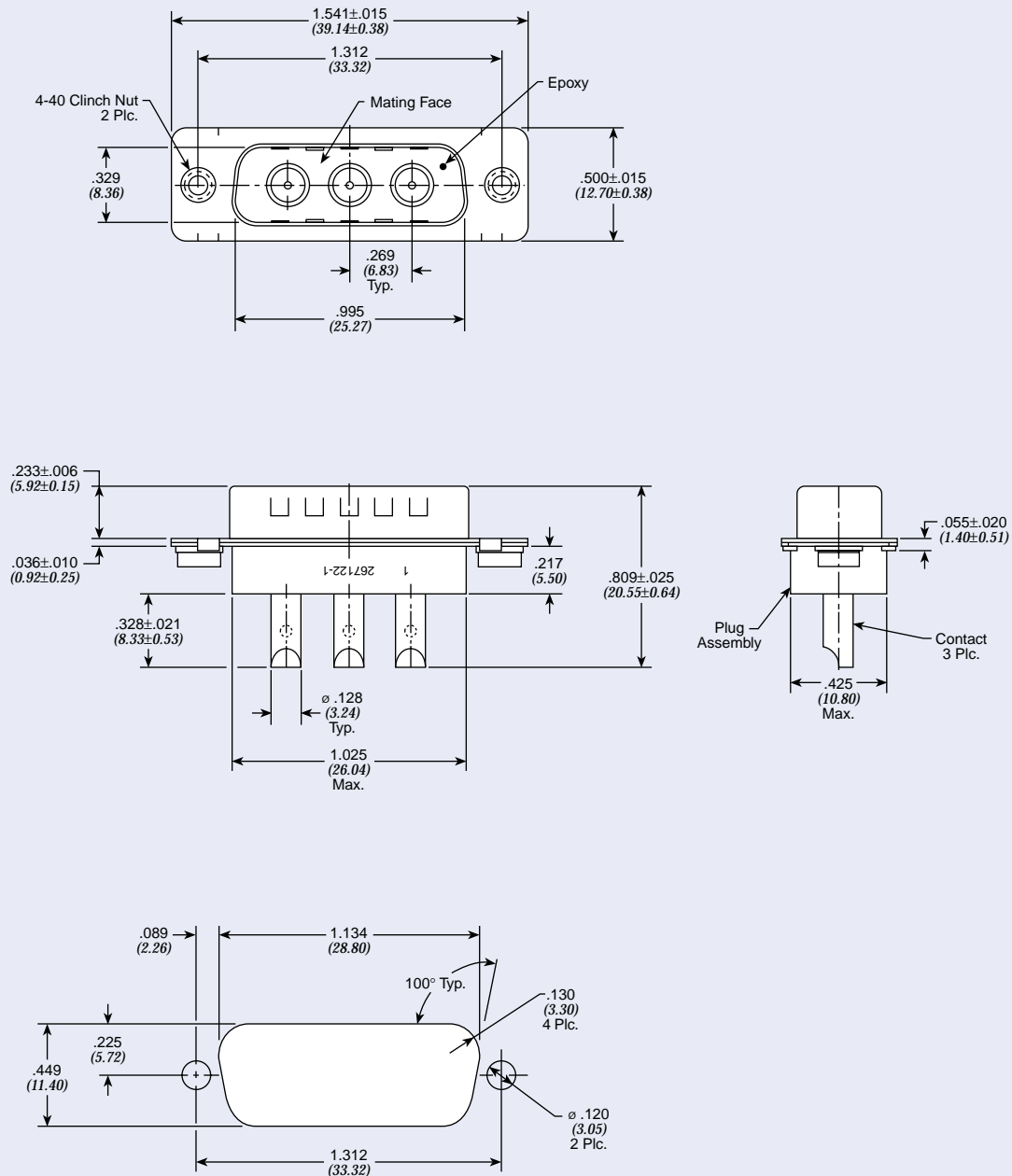

**Recommended Panel Cutout**

Only represents a few of our available configurations. Consult factory for more information.

Dimensions in inches (mm)

# Filtered Combo D-Subminiature Connectors 3W3

## Plug - Right Angle

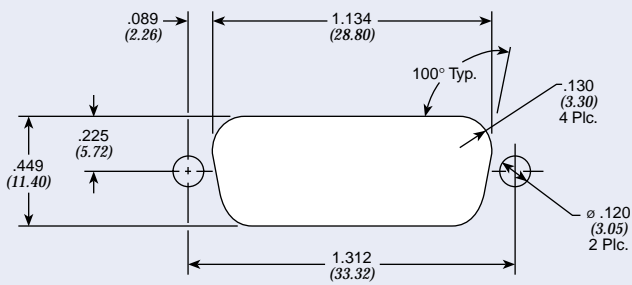
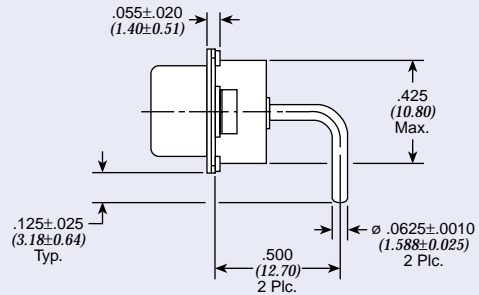
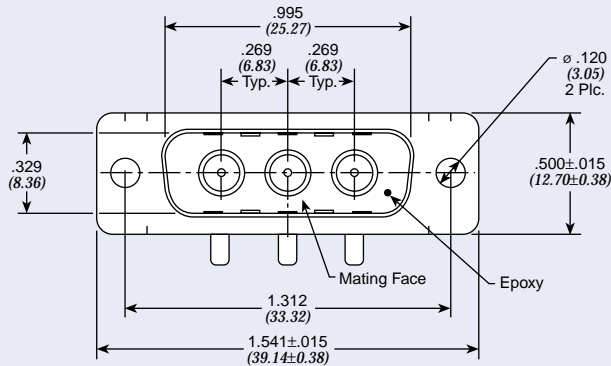
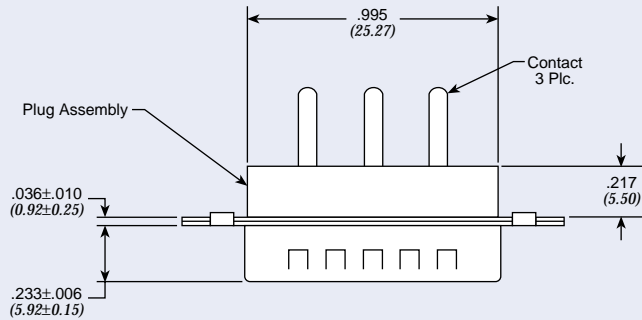

Recommended Panel Cutout

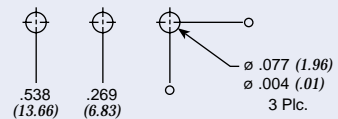

Only represents a few of our available configurations. Consult factory for more information.

Dimensions in inches (mm)

# Filtered Combo D-Subminiature Connectors 5W5

## Plug - Vertical

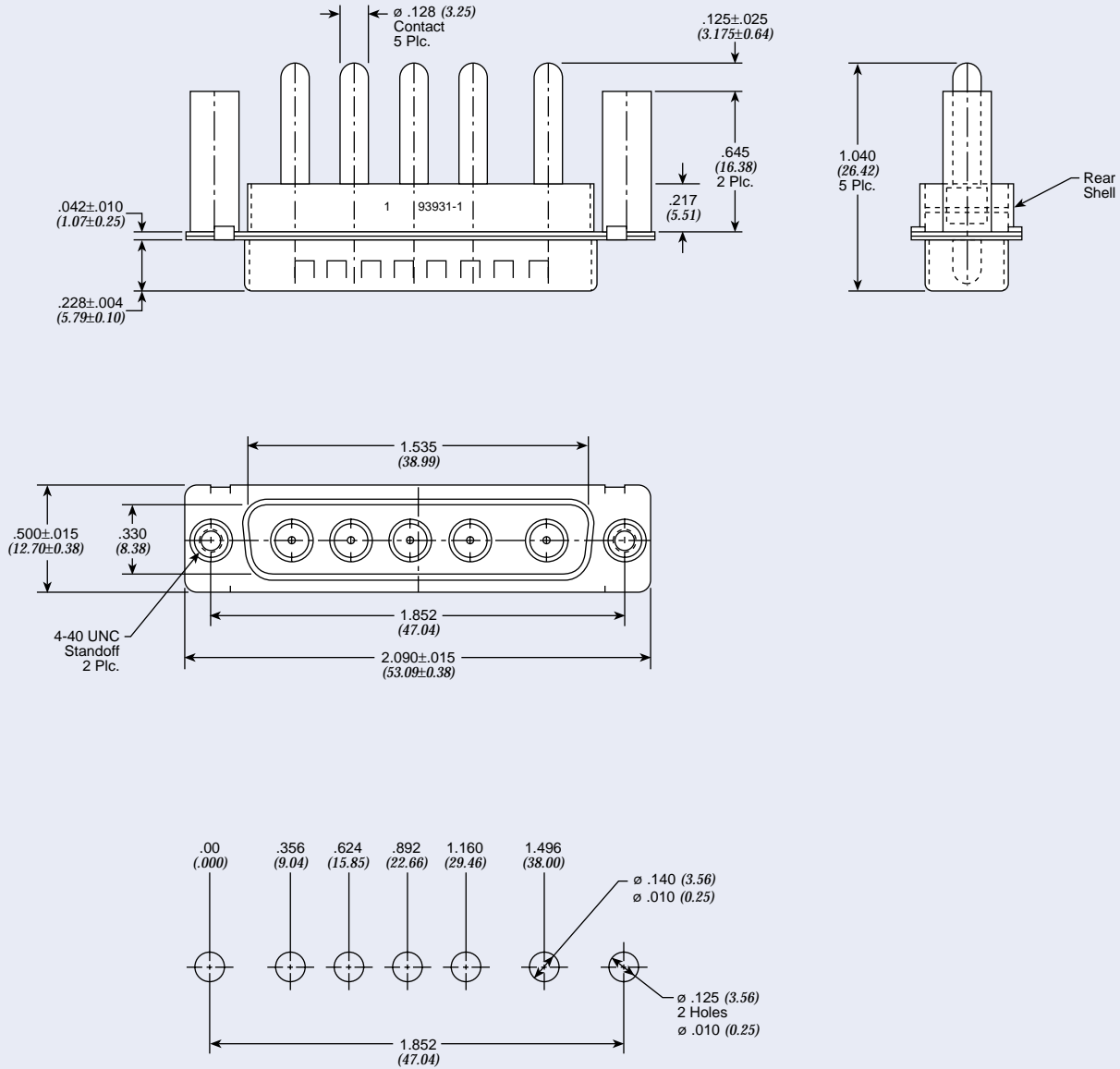

Recommended PCB Layout

Only represents a few of our available configurations. Consult factory for more information.

Dimensions in inches (mm)

# Filtered Combo D-Subminiature Connectors 9W4

## Socket - Solder Cup

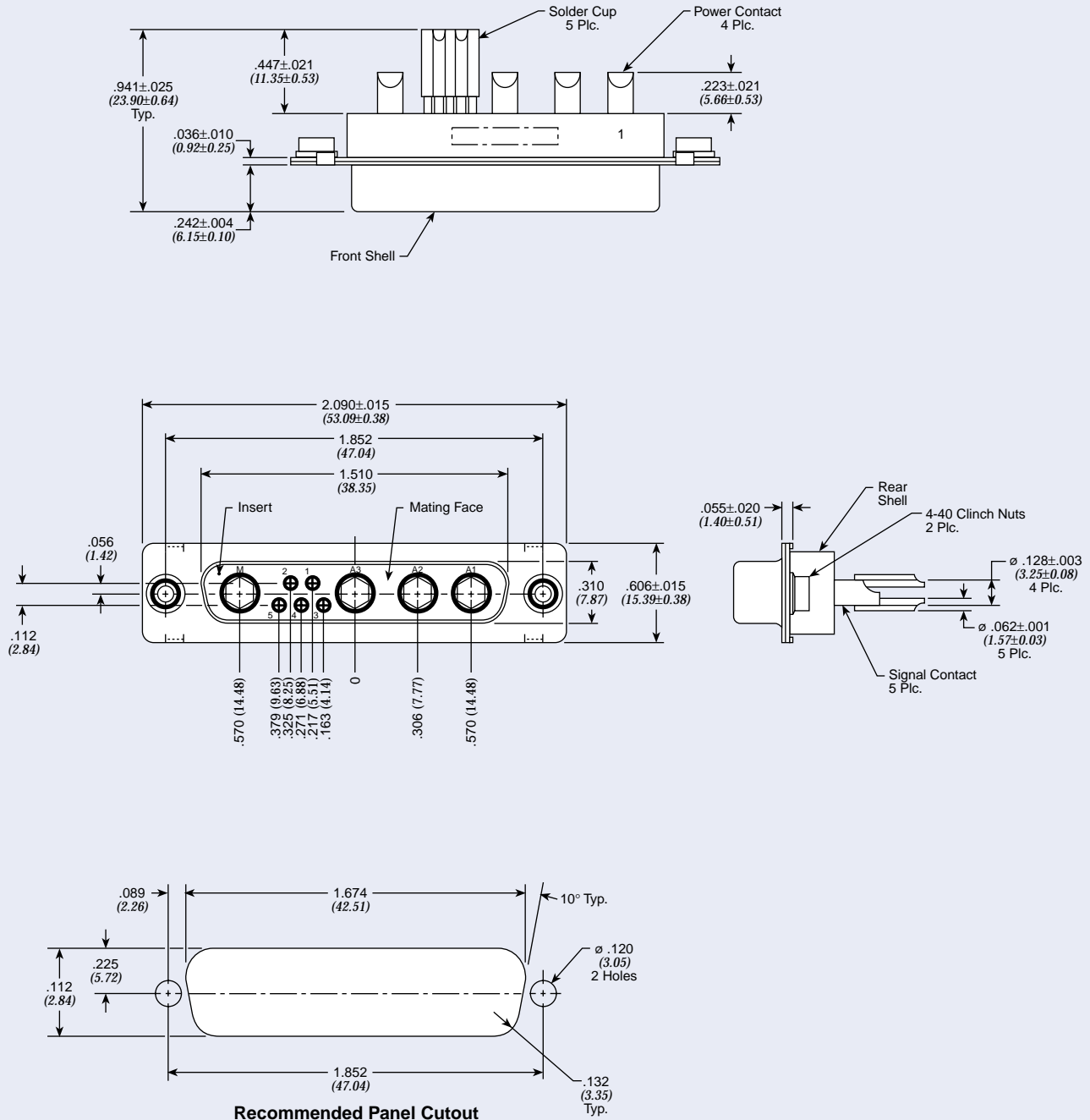

Only represents a few of our available configurations. Consult factory for more information.

Dimensions in inches (mm)

# Filtered Combo D-Subminiature Connectors 9W4

## Socket - Vertical

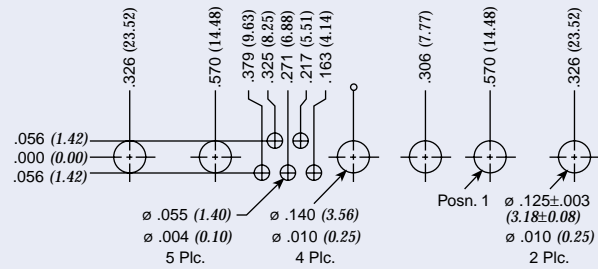
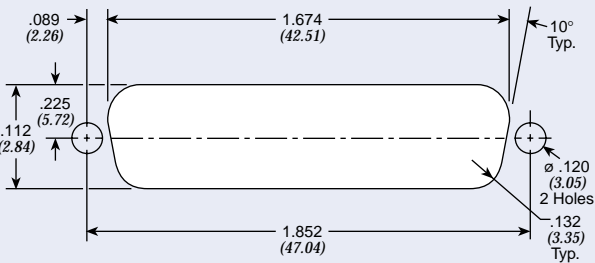
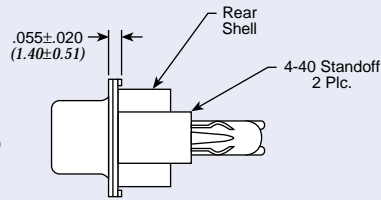
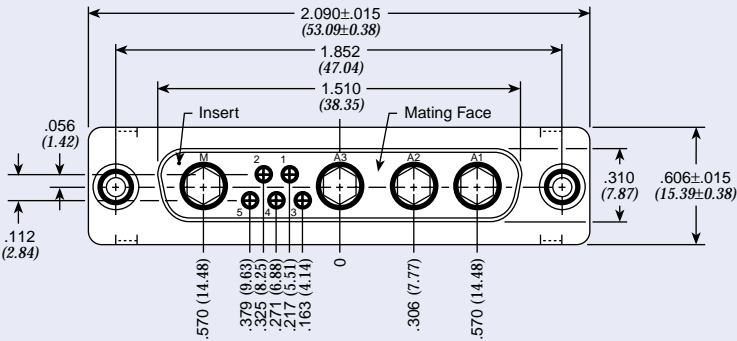
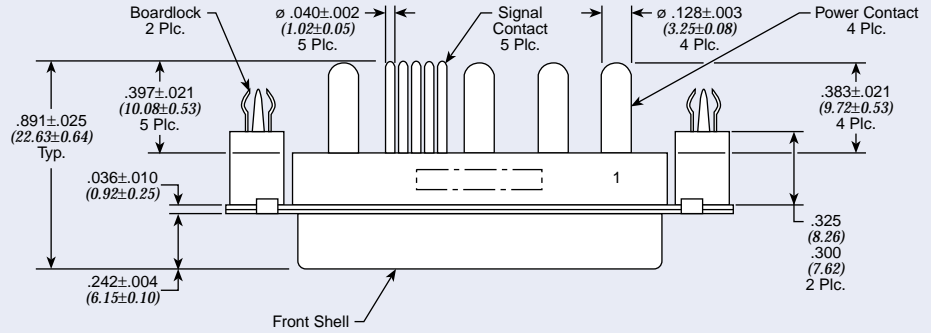

Only represents a few of our available configurations. Consult factory for more information.

Dimensions in inches (mm)

# Filtered Combo D-Subminiature Connectors 9W4

## Plug - Right Angle

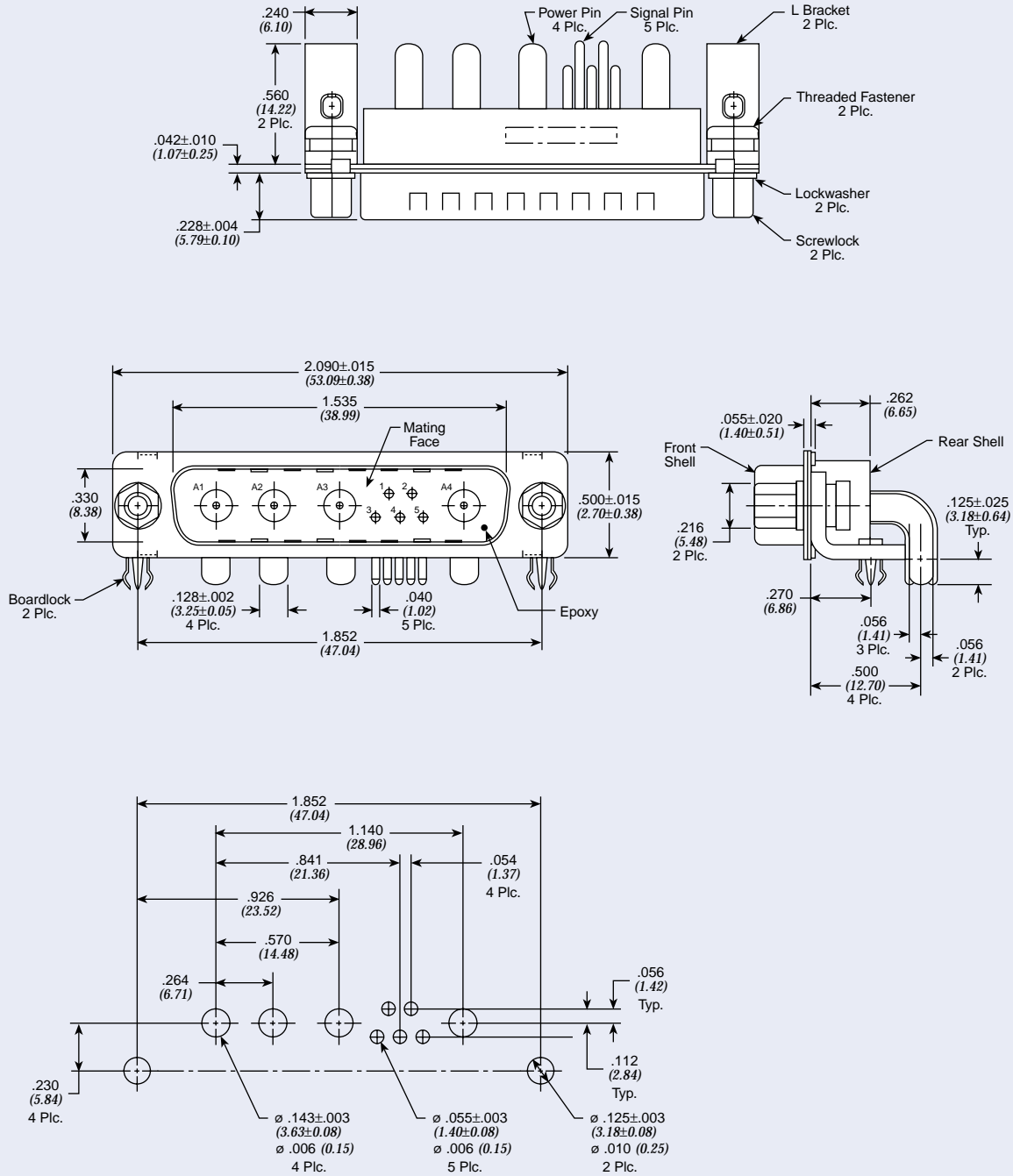

**Recommended PC Board Mounting Dimensions**

Only represents a few of our available configurations. Consult factory for more information.

Dimensions in inches (mm)

# Filtered Combo D-Subminiature Connectors 24W7

## Socket - Solder Cup

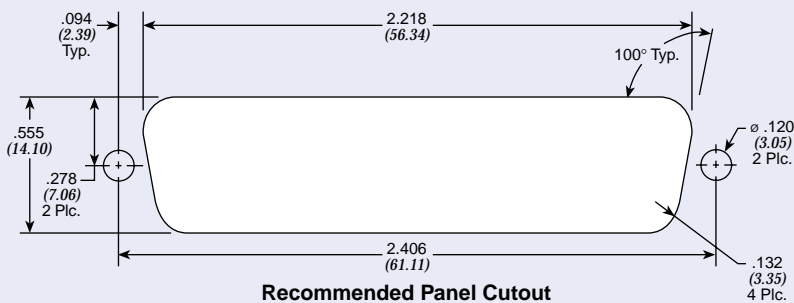
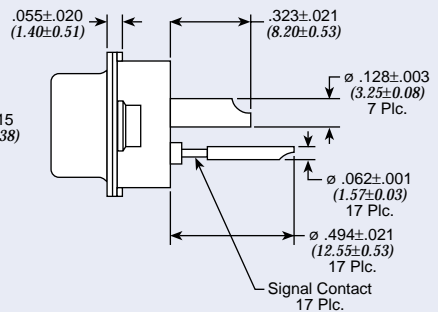
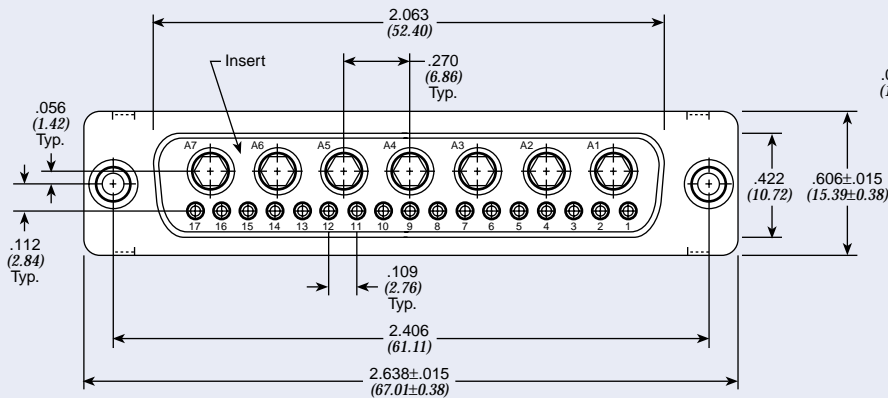
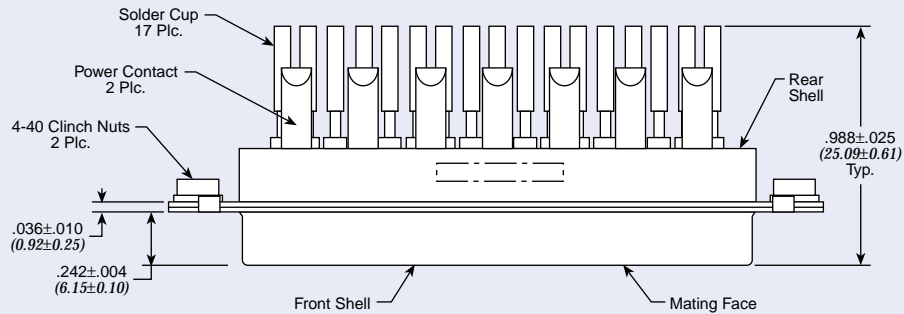

Only represents a few of our available configurations. Consult factory for more information.

Dimensions in inches (mm)

# Series E (ESD/EFT) Transient Protected Connectors

These fully integrated connectors and adapters provide protection from Electro Static Discharge (ESD) and Electronically Fast Transients (EFT) that can damage or even destroy your equipment. The connectors are designed to meet various IEC 61000-4 standards, and are offered in a wide range of clamping voltages to fit your specific application. The connectors have integrated ESD transient voltage suppressors from Littelfuse®, are available in industry standard sizes and are “drop in” replacements for unprotected connectors.

They are available with various capacitance levels to condition your signals to handle EMI issues at the same time or with as little as a 0.05 pF to protect the integrity of your signal in high speed or digital applications.

## Features

- **ESD/EFT protection at the I/O ports** – Prevents the transients from entering the system before they can cause harm or create EMI problems.
- **Low ground impedance** – The metallic shell provides minimal impedance to direct the damaging transient spikes to ground, which is essential for proper protection.
- **Removal of ground traces from the board** – This eliminates potential line-to-line noise problems and spark-overs between ground and signal lines.
- **Complete protection** – All lines, including ground lines, have bi-directional protection.
- **Efficient space utilization** – Standard footprints save valuable board space in terms of not only components, but also extra ground traces.
- **Fewer components** – Reduces total number of components purchased, stocked, placed and tested; yielding the savings of all the hidden costs involved in these activities, while reducing your supplier base.
- **Available capacitance** – Available with various capacitance values to supply low pass properties along with the transient protection, thus supplying ESD/EFT and EMI protection all in one complete package. The metal shell also provides EMI shielding of system. Parts are available with capacitance values less than 50 pF for digital and very high speed signal lines.



## Typical Time-Voltage Curves

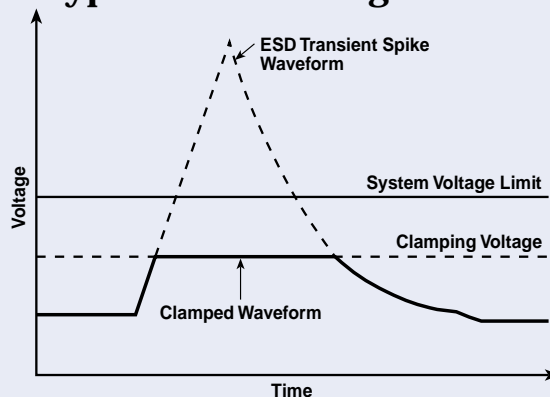

Typical Time-Voltage Curve of Transient Spike on Integrated Protected Connector with Capacitance (Parts with Working Voltage Code starting with 0)

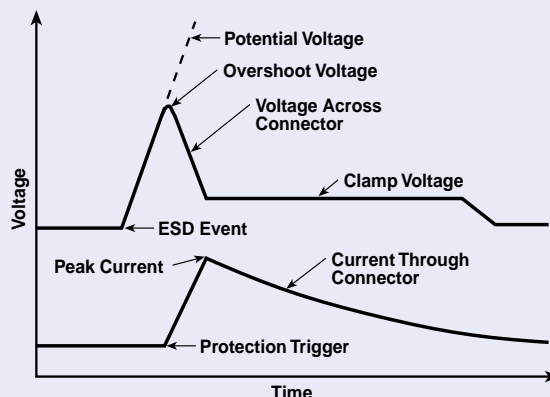

Typical Time-Voltage Curve of Low Capacitance Integrated Protection (Parts with Working Voltage Code starting with P)

## Mechanical Specifications

- Front Shell* . . . . . Steel, tin plated
- Housing* . . . . . 94V-0 rated thermoplastic, black
- Eyelets* . . . . . Brass, tin plated
- Threaded Inserts* . . . . . Zinc
- Boardlocks* . . . . . Copper alloy, tin-lead plated
- Pin Contacts* . . . . . Brass
- Socket Contacts* . . . . . Phosphor Bronze
- Contact Plating* . . . . . Duplex plated as follows:  
15uin (.38um) gold on mating end, with entire contact 50uin (1.27um) min. nickel underplated.

# Series E (ESD/EFT) Transient Protected Connectors

## Ordering Information

Example: **56-E04-005-5-T**

This part number represents a Series E connector with a shell size of 9 and a socket to right angle configuration. The maximum working voltage is 5.5 VDC and the connector has a .590" footprint with 4-40 threads.

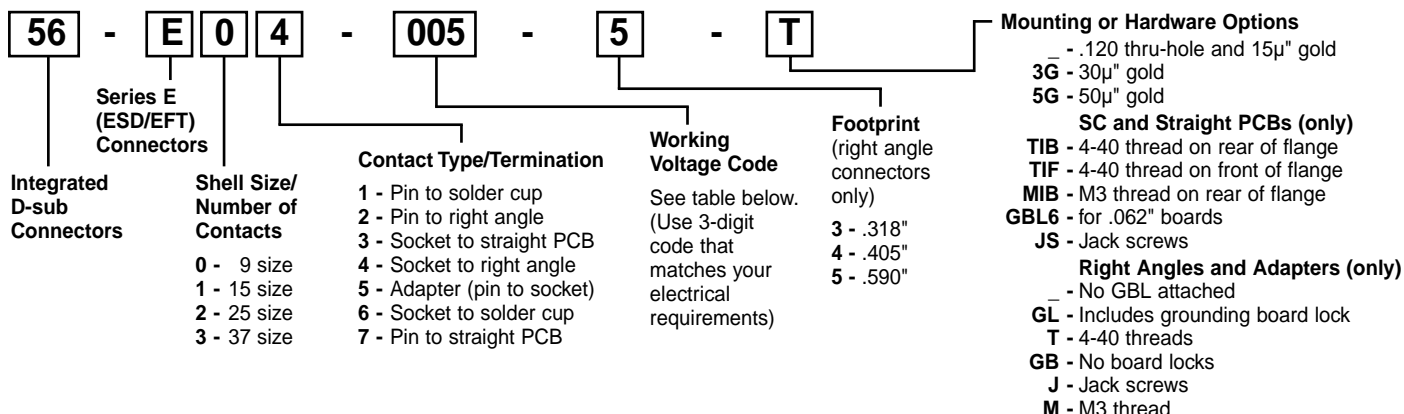

## Transient Voltage Protection with Capacitance

Immunity to IEC 61000-4-2 (ESD) up to level 4 and IEC 61000-4-4 (EFT) air and contact discharge specifications.

Working Voltage Code	Max. Working Voltage VDC	Max. Working Voltage VAC	Clamp Voltage 8 x 20 μs	Peak Current 8 x 20 μs	V breakdown 1 ma	Energy (J) 10 x 100 μs	Typical Cap. pF at 1 MHz	
003	3.5	2.5	10.0@5A	120	5 (3.7-7.0)	0.3	2200	
005	5.5	4.0	15.5@5A	120	8 (7.1-9.3)	0.3	1600	
009	9.0	6.5	20.0@2A	40	12 (11-14)	0.1	450	
012	12.0	9.0	25.0@2A	40	16 (14-18.5)	0.1	350	
014	14.0	10.0	30.0@5A	120	18 (15.9-20.3)	0.3	480	
018	18.0	14.0	40.0@5A	120	25 (22-28)	0.3	450	
026	26.0	20.0	58.0@5A	100	34 (29.5-38.5)	0.3	190	
030	30.0	25.0	65.0@2A	30	42 (37-46)	0.1	80	
	>30.0	>25.0	Please consult factory for availability					

**Notes:** Consult factory for custom capacitance values. Typical leakage at 25°C is <25 μA  
Maximum leakage 50 μA at V<sub>m(DC)</sub>

## Transient Voltage Protection without Significant Capacitance

Immunity to IEC 61000-4-2 (ESD) up to Level 4 air and contact discharge. Excellent for digital, high speed and high frequency signals.

Working Voltage Code	Max. Working Voltage (V) DC	Typical Clamp Voltage	Overshoot Voltage	Leakage (A) Current	Typical Cap. at 1 MHz
P24	24.0	≤150 V	≤1000 V	<1.0 nA	0.05 pF

## Board Layouts

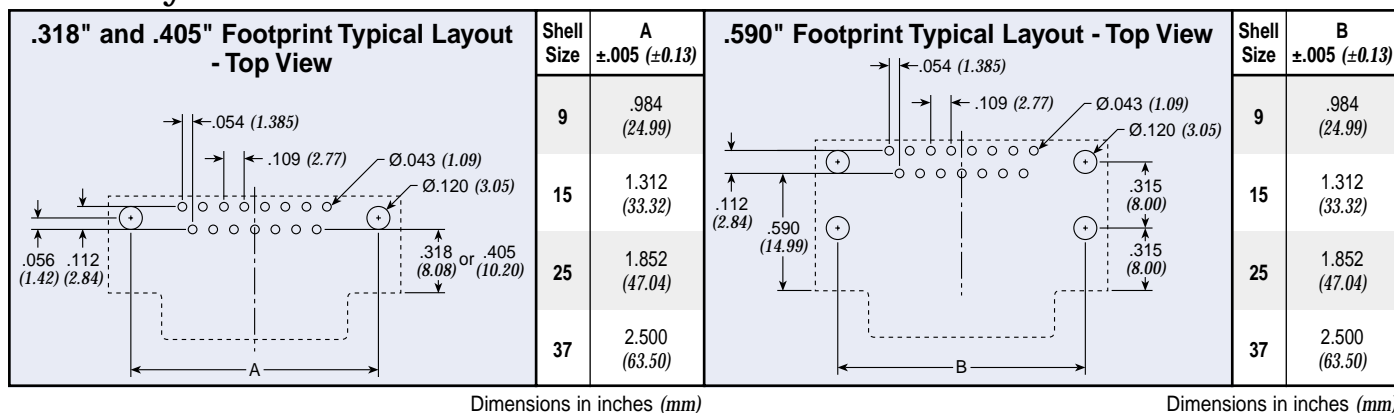

# Series E (ESD/EFT) Transient Protected Connectors

### Pin Contact (plug) Straight PC Mount

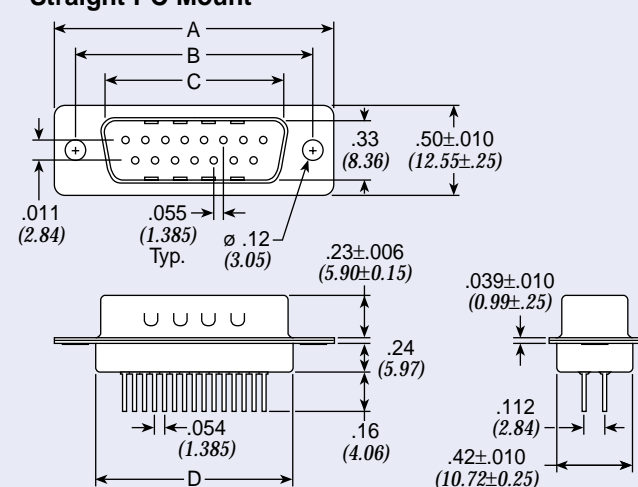

### 90° PC Mount

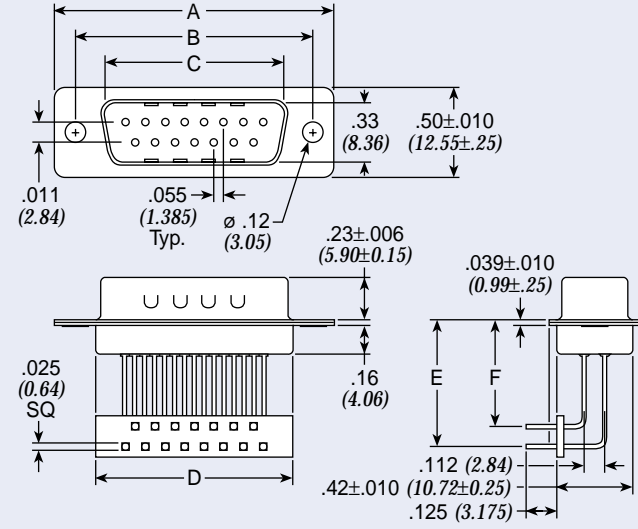

Size	A	B	C	D
9	1.213±.015 (30.81±0.38)	.984±.005 (24.99±0.13)	.667±.010 (16.92±0.25)	.755 (19.18)
15	1.541±.015 (39.14±0.38)	1.312±.005 (33.32±0.13)	.994±.010 (25.25±0.25)	1.083 (27.51)
25	2.088±.015 (53.04±0.38)	1.852±.005 (47.04±0.13)	1.534±.010 (38.96±0.25)	1.614 (41.00)
37	2.73±.015 (69.32±0.38)	2.50±.005 (63.50±0.13)	2.18±.010 (55.42±0.25)	2.27 (57.71)

Footprint	E	F
.318	.430 (10.92)	.318 (8.08)
.405	.517 (13.13)	.405 (10.29)
.590	.700 (17.83)	.590 (14.99)

Dimensions in inches (mm)

### Socket Contact (receptacle) Straight PC Mount

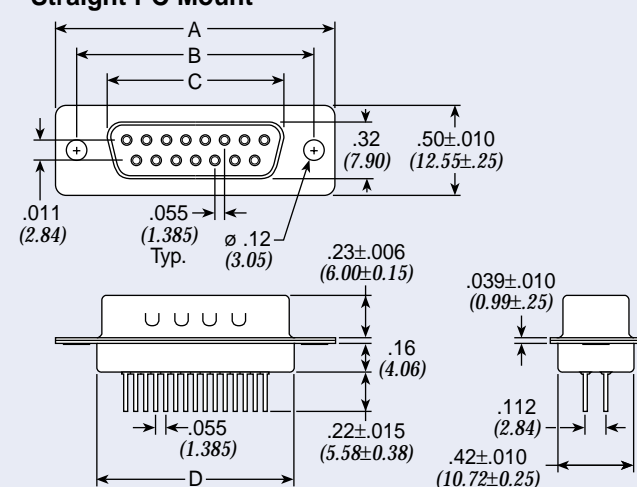

### 90° PC Mount

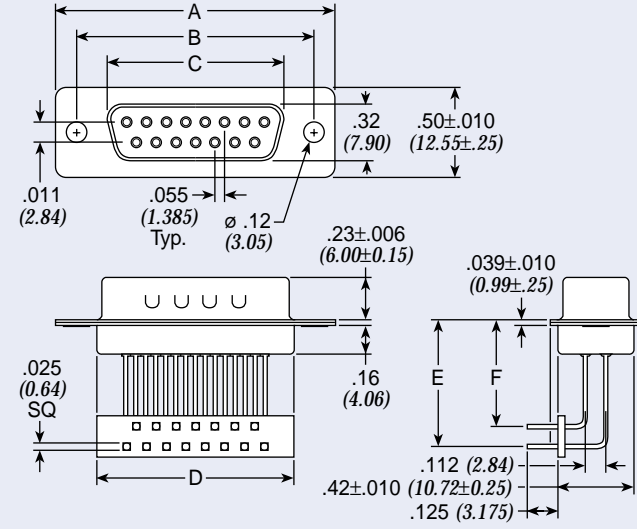

Size	A	B	C	D
9	1.213±.015 (30.81±0.38)	.984±.005 (24.99±0.13)	.643±.010 (16.33±0.25)	.755 (19.18)
15	1.541±.015 (39.14±0.38)	1.312±.005 (33.32±0.13)	.971±.010 (24.66±0.25)	1.083 (27.51)
25	2.088±.015 (53.04±0.38)	1.852±.005 (47.04±0.13)	1.511±.010 (38.38±0.25)	1.614 (41.00)
37	2.73±.015 (69.32±0.38)	2.50±.005 (63.50±0.13)	2.16±.010 (54.84±0.25)	2.27 (57.71)

Footprint	E	F
.318	.430 (10.92)	.318 (8.08)
.405	.517 (13.13)	.405 (10.29)
.590	.700 (17.83)	.590 (14.99)

Dimensions in inches (mm)

# Series E (ESD/EFT) Transient Protected Connectors

## Pin Contact (plug) Solder Cup Termination

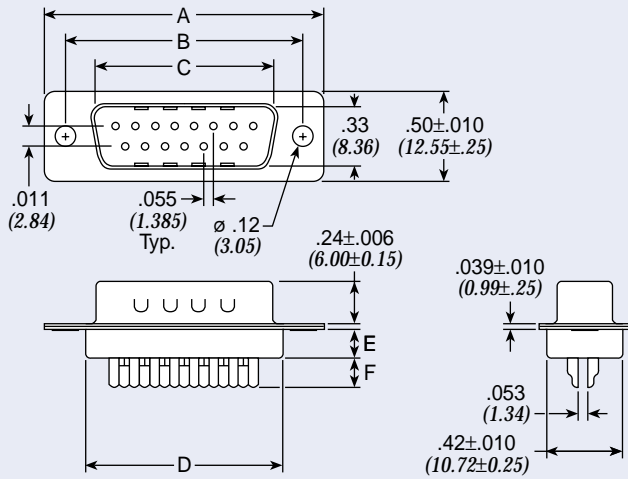

## Socket Contact (receptacle) Solder Cup Termination

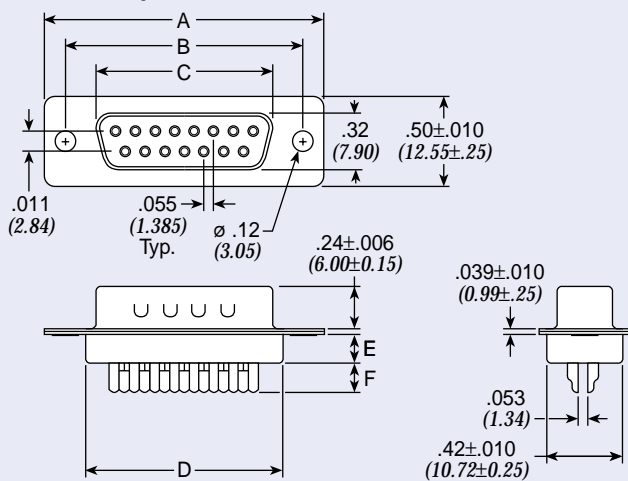

Size	A	B	C	D	E	F
9	1.213±.015 (30.81±0.38)	.984±.005 (24.99±0.13)	.643±.010 (16.33±0.25)	.755 (19.18)	.16 (4.06)	.16 (4.06)
15	1.541±.015 (39.14±0.38)	1.312±.005 (33.32±0.13)	.971±.010 (24.66±0.25)	1.083 (27.51)	.16 (4.06)	.16 (4.06)
25	2.089±.015 (53.04±0.38)	1.852±.005 (47.04±0.13)	1.511±.010 (38.38±0.25)	1.615 (41.00)	.16 (4.06)	.16 (4.06)
37	2.73±.015 (69.32±0.38)	2.50±.005 (63.50±0.13)	2.16±.010 (54.84±0.25)	2.27 (57.71)	.16 (4.06)	.16 (4.06)

Dimensions in inches (mm)

## Pin - Socket Adapter

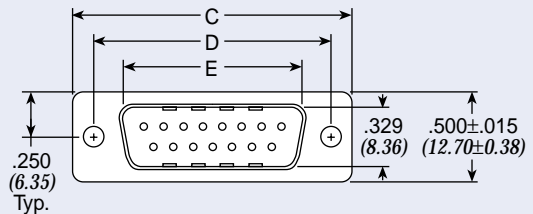
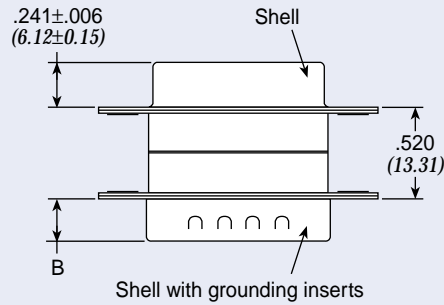
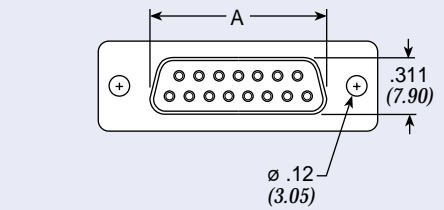

Size	A	B	C	D	E
9	.642 (16.31)	.233±.006 (5.92±.15)	1.213±.015 (30.81±.38)	.984 (24.99)	.667 (16.94)
15	.970 (24.64)	.233±.006 (5.92±.15)	1.541±.015 (39.14±.38)	1.312 (33.33)	.995 (25.27)
25	1.511 (38.38)	.228±.006 (5.80±.15)	2.088±.015 (53.04±.38)	1.852 (47.05)	1.532 (38.92)
37	2.158 (54.82)	.228±.006 (5.80±.15)	2.729±.015 (69.32±.38)	2.500 (63.50)	2.183 (55.45)

Dimensions in inches (mm)

# Filtered Miniature Ribbon Connectors

Filtered miniature ribbon connectors are fully intermateable and interchangeable with existing standard product. Rugged design construction and predictable capacitive filter performance is available in right-angle and male/female adapter versions.

Applications for this type of connector are widely diversified and include all phases of the telecommunications industry including original telephone manufacturing, operating telephone companies, cable reclamation, cable manufacturing and bay connectorization. The filtered miniature ribbon connector line is also ideally suited for use in printers, computer terminals, test equipment, business and copying machines, telemetering, and various equipment used in the security industry.

## Features

- Lower installed cost
- Assists with FCC Part 15; available for Part 68 requirements
- Applicable for VDE specifications 0871, 0875-0878, Vfg Federal Regulations and VCCI noise requirements
- Drop-in replacement, matched footprint
- All circuit lines filtered
- Connector body is recognized under the Component Recognition Program of Underwriters Laboratories, Inc.
- Plastic components are UL94V-0 rated
- Connector body is certified by Canadian Standard Association

## Mechanical Specifications - Adapter

Shell . . . . . Zinc  
 Thermoplastic  
 Insert . . . . . Black, high strength  
 Contacts . . . . . Copper alloy  
 Contact Plating . . . . . 30uin (.76um) (min.)  
 gold over nickel

## Mechanical Specifications - Connector

Shell . . . . . Steel, tin plated  
 Thermoplastic  
 Insert . . . . . Blue, 30% glass filled  
 Contacts . . . . . Phosphor bronze  
 Contact Plating . . . . . Gold flash (<10 μ in) over nickel

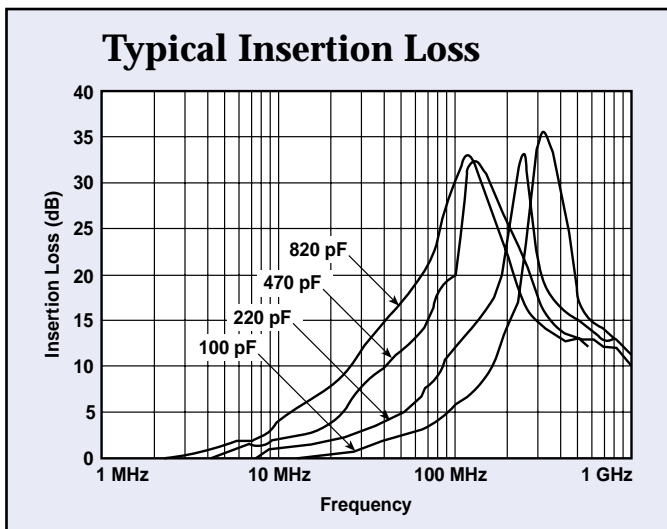

## Electrical Specifications

Operating Temperature . . . . . -55°C - 105°C  
 Dielectric Withstanding Voltage . . . . . 1000 VAC min per (FCC Part 68 test)  
 Capacitance . . . . . 100 pF, 220 pF, 470 pF, 820 pF, ±15% (adapter), ±20% (connector)  
 Dissipation Factor . . . . . 2.5% max (adapter)  
 5% max (connector)

# Filtered Miniature Ribbon Connectors 50 Position

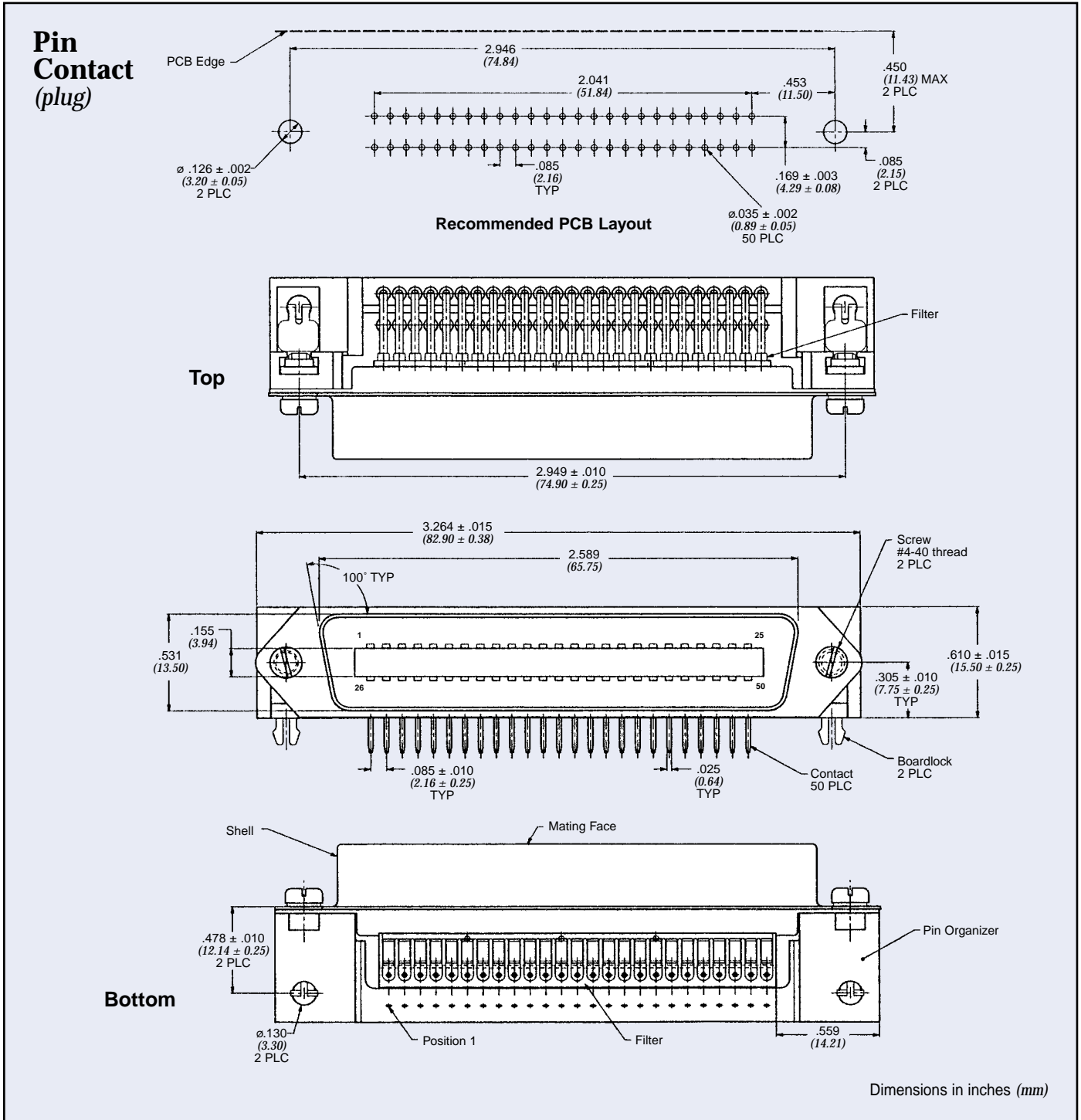

Part Number	Capacitance Value
56-882-002	100 pF, $\pm$ 20%
56-882-003	220 pF, $\pm$ 20%
56-882-004	470 pF, $\pm$ 20%
56-882-005	820 pF, $\pm$ 20%

# Filtered Miniature Ribbon Connectors 50 Position

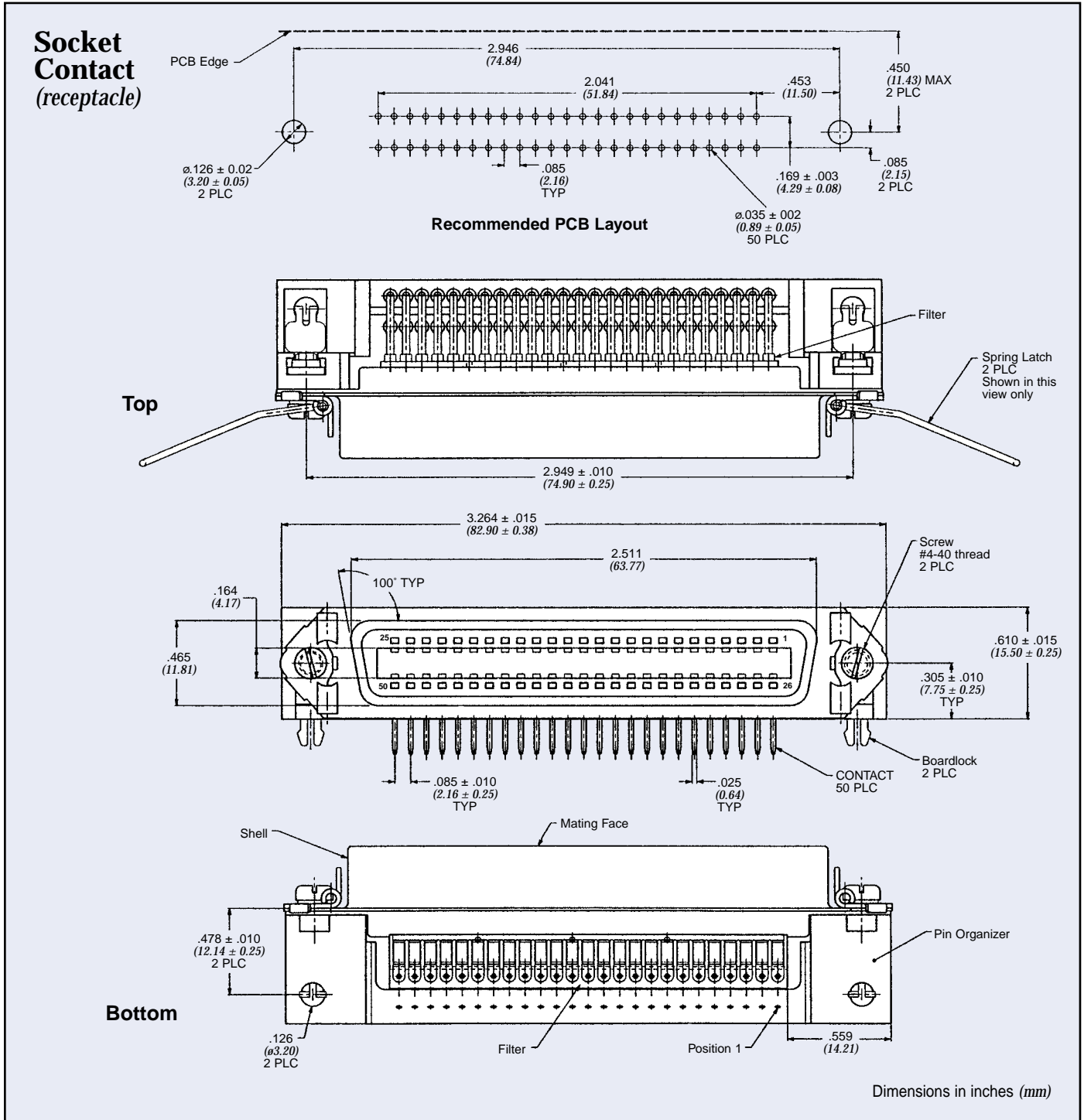

Part Number	Capacitance Value
56-886-002	100 pF, ±20%
56-886-003	220 pF, ±20%
56-886-004	470 pF, ±20%
56-886-005	820 pF, ±20%

# Filtered Miniature Ribbon Connectors 50 Position

## Adapter

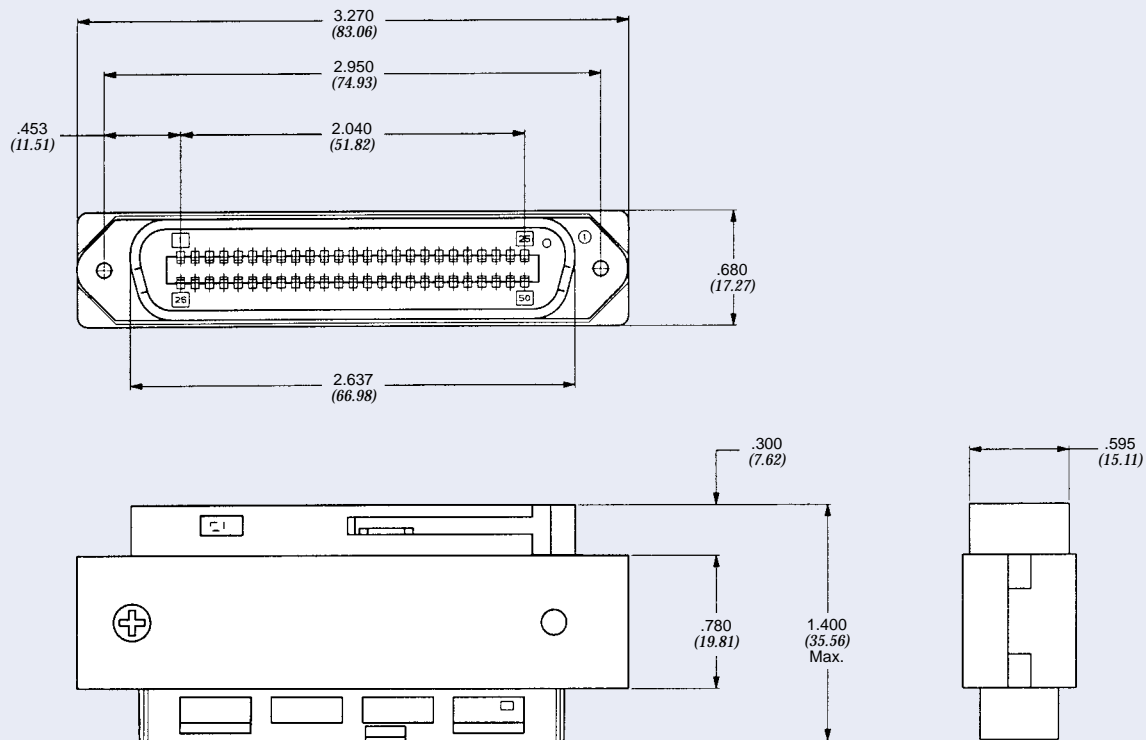

Dimensions in inches (mm)

Part Number	Capacitance Value
56-889-002	100 pF ±15%
56-889-003	220 pF ±15%
56-889-004	470 pF ±15%
56-889-005	820 pF ±15%

Hardware options also available. Consult factory for more information.

# Filtered Modular Jack Connectors

Protecting signals from electromagnetic interference (EMI) is now more important than ever. Spectrum Control gives you more choices in keeping your signals clean and free of EMI. Whatever the level of protection your application requires, we offer signal conditioning products that meet any level of price and performance.

These compact, low-cost, filtered printed circuit board RJ45 modular jack connectors from Spectrum Control offer an inexpensive way to protect equipment from conducted and radiated electromagnetic interference (EMI), while meeting all appropriate performance requirements. Offering compact size and high reliability, these new connectors are fully intermateable and interchangeable with existing standard product. The low profile and narrow width of the multi-port style allows more ports to be packed into less space.

Filtering options include ferrite only (L), or capacitive film only (C). Ferrite versions can be supplied in fully shielded, partially shielded or unshielded versions. Capacitive versions come with full, or partial shielding. Redundant shielding tabs ensure that a low impedance ground path is maintained across the interface; tabs are available in board-ground or panel-ground versions, with panel-ground jacks also incorporating board-ground legs. These flame retardant polyester thermoplastic connectors are compatible with wave solder environments, and employ duplex plated contacts with solder tails.

Modular jack connectors assist with FCC Part 15 A & B; and CISPR 22 compliance.

Applications for this type of connector are widely diversified and include: LANs, WANs, network cards, broadband transmission equipment, workstations, peripherals, fax/modems, copy machines and multiplexing.

## Features

- Lower installed cost
- Assists with FCC Part 15 A & B; and CISPR 22 compliance
- Drop-in replacement, matched footprint
- All circuit lines protected
- Inductor or capacitor versions
- Capacitive versions feature:
  - Dielectric withstanding voltage 500 VDC maximum
  - Insulation resistance 1 Gohm @ 100 VDC
  - Current capacitance values of 110 pF ± 30%
- Available with two grounding options – PCB or parallel
- Unshielded, partial or fully shielded versions
- Certified by Canadian Standards Association File No. LR 7189
- Certified by Underwriters Laboratories, Inc., File Number E81956



## Equivalent Circuit (Capacitive Version)

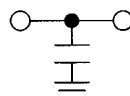

## Typical Insertion Loss vs. Frequency (Capacitive Version)

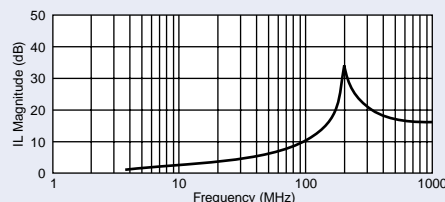

## Equivalent Circuit (Ferrite Version)



## Typical Impedance vs. Frequency (Ferrite Version)

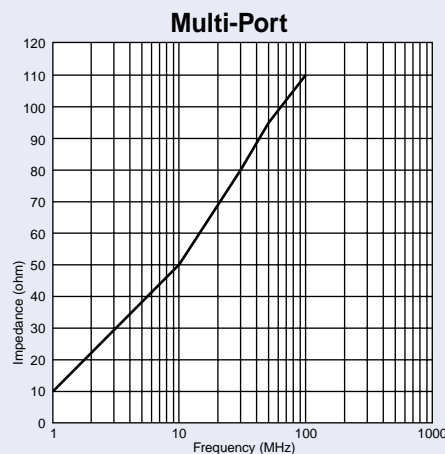
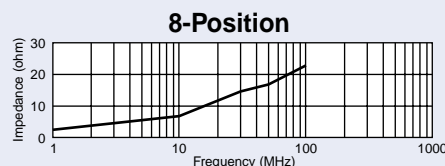

# Filtered Modular Jack Connectors

## Ordering Information

Example: **56-A52-002-1130**

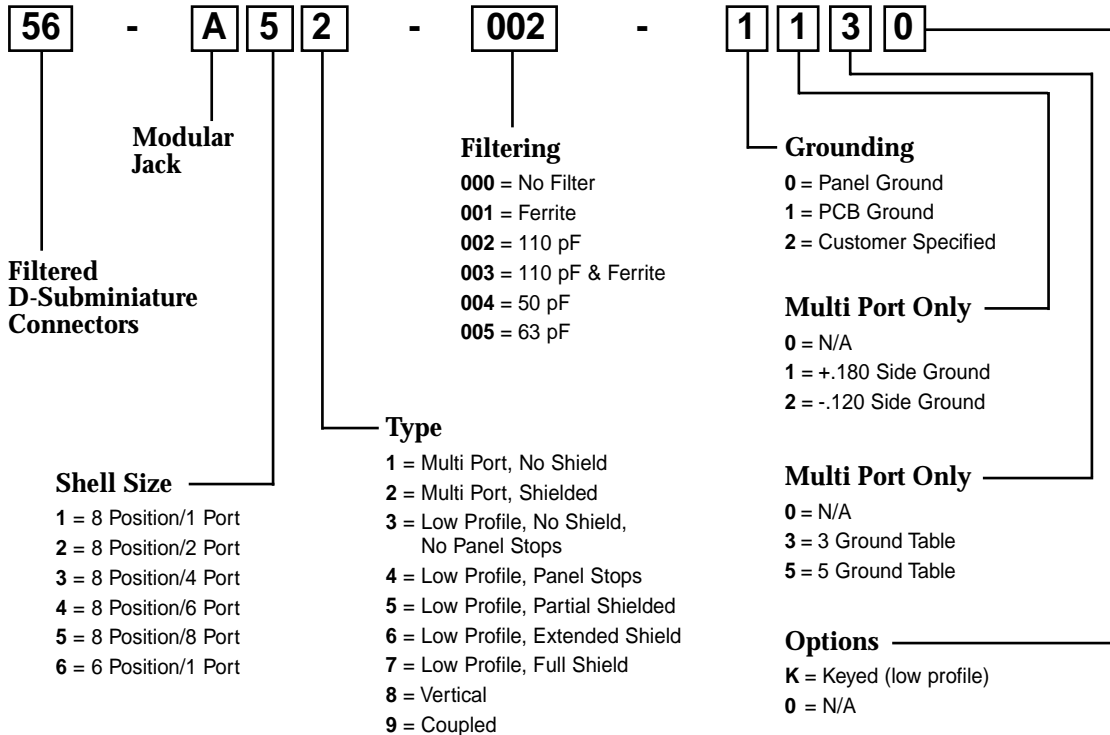

## Typical Dimensions

For 56-A17-002-0000

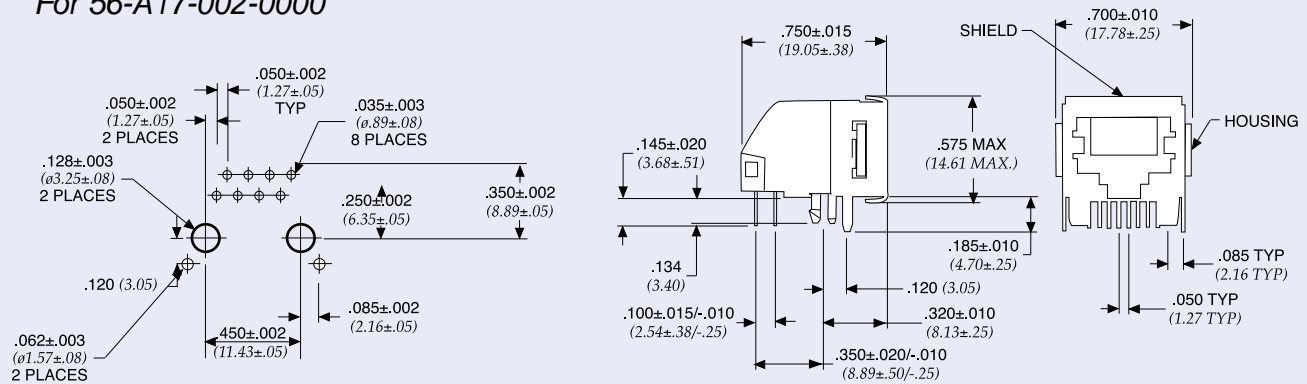

Dimensions in inches (mm)

# Filtered Modular Jack Connectors



## Typical Dimensions

For 56-A18-005-1000 Vertical Mod Jack

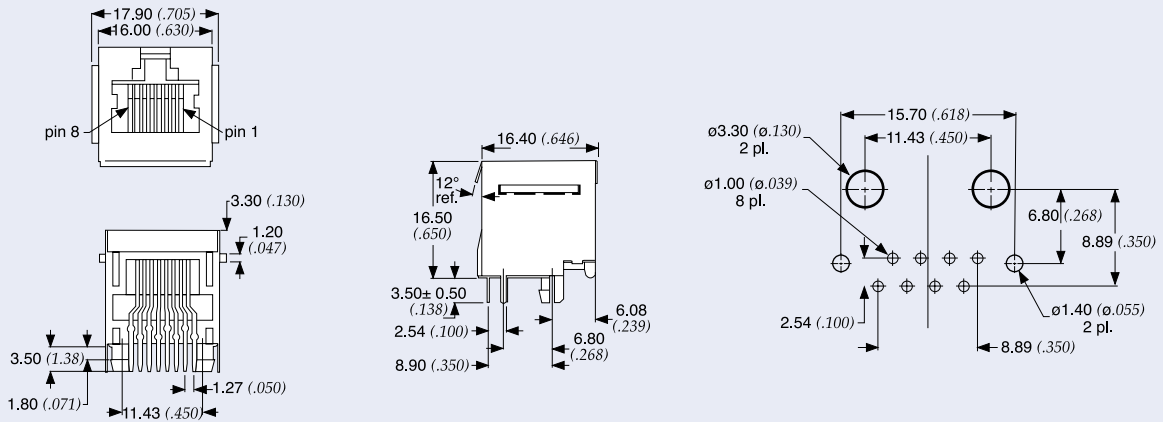

Dimensions in inches (mm)

## Typical Dimensions

For 56-A52-002-0130 Ganged Mod Jack

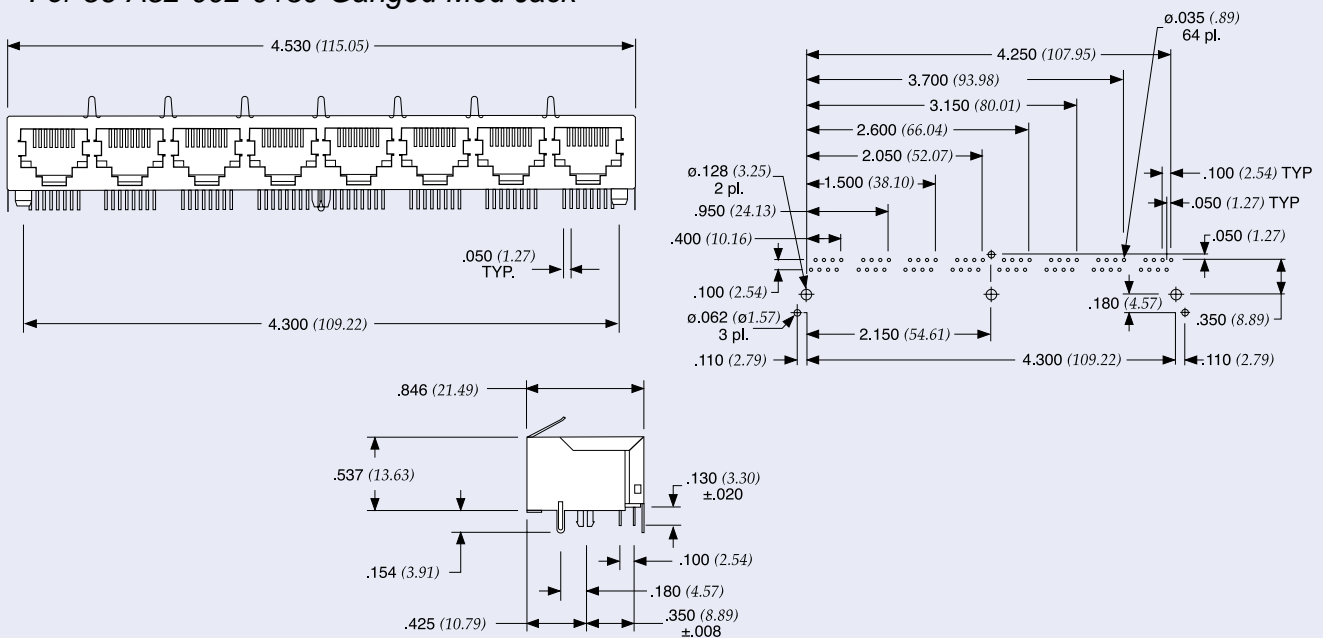

Dimensions in inches (mm)

# Filtered Mini-DIN Connectors

Filtered mini-DIN connectors are available in several configurations and sizes. These are “drop-in” replacements for standard unfiltered connectors with matched footprints. Housings are made of high temperature UL94V-0 rated thermoplastic material. Connectors are available with full metal shields and kinked or straight ground tabs. Each size can be filtered with ferrites or chip capacitors.

Primary applications are in computer keyboard and mouse connections.

## Features

- Audio, video and computer equipment
- Drop-in replacement for unfiltered connectors
- Shielded, ferrite or capacitive filtering

## Ordering Information

Example: **56-B32-000-S**

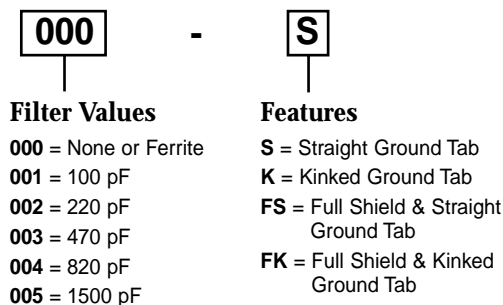
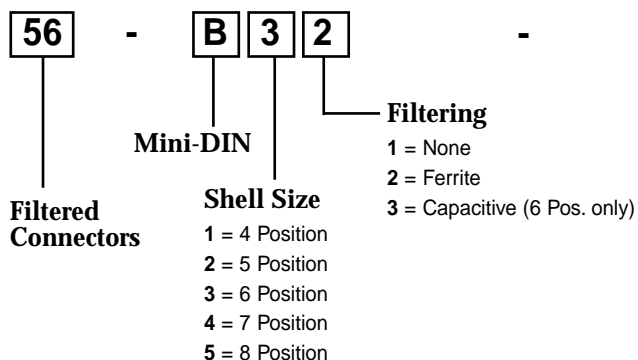

## Specifications

<i>Contacts</i>	.....Copper alloy, gold over nickel plating
<i>Shield</i>	.....Brass, tin plated
<i>Housing</i>	.....94V-0 rated thermoplastic, black
<i>Current rating</i>	.....1A @ 12 VDC
<i>DWV</i>	......500 VDC
<i>Insulation Resistance</i>	......500MOhms min
<i>Operating Temp</i>	.....-25°C to +70°C
<i>Typical Ferrite Impedance</i>	......20-22 Ohm @ 100 MHz
<i>Typical insertion loss</i>	......32 db @ 200 MHz



## Typical Dimensions

For 56-B32-000-S

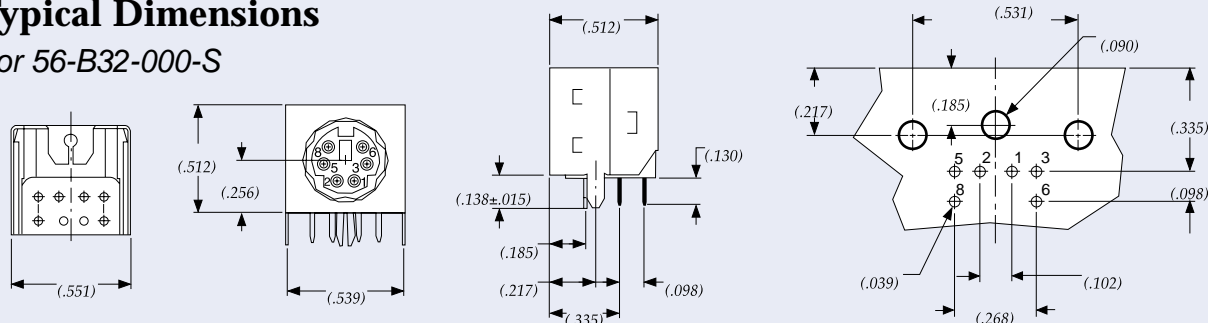

Dimensions in inches (mm)

# D-Subminiature Adapter Test Kit & Hardware

## Adapter Test Kit

Specially designed for EMI evaluation process

- Male/female adapter part
- Easily plugged into equipment under testing conditions
- Ideal for new products and retrofitting
- Each adapter test kit includes:
  - 20 filtered adapters
  - Four shell sizes 9, 15, 25 and 37
  - Five filter ranges:
    - 310 pF Pi
    - 830 pF FT
    - 1000 pF Pi
    - 2500 pF Pi
    - 4000 pF Pi

## Ordering Information

Description	Spectrum Part Number
Adapter test kit	56-700-002
Adapter test kit with Jackscrew <i>Includes 40 pcs. 56-201-006</i>	56-700-002-JS
Hexagonal Spacer	56-201-001
Jackscrew Mounting Hardware <i>For .312" (7.92 mm) length</i>	56-201-004
Jackscrew Mounting Hardware <i>For .688" (17.47 mm) length</i>	56-201-006
Series 100 adapter test kit	56-100-002



Adapter Test Kit

## Hardware

Designed to provide simple and effective mounting

### Hexagonal Spacer

- Tapped spacer fits between flanges
- Provide retrofit of 4-40" threads
- Two spacers per adapter required, packaged in bulk

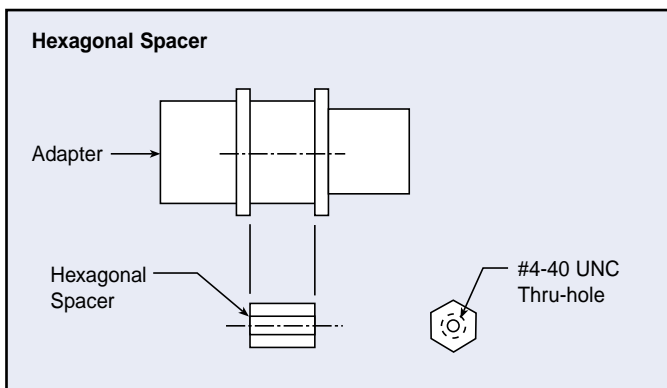

### Jackscrew Mounting Hardware

- Male/female jackscrews
- Standard 4-40 threads for compatibility
- Two male thread lengths available
- Two screws per adapter required
- Lockwasher included, packaged in bulk

# High Voltage Filtered Connector Adapters

Spectrum Control has developed a male/female filtered connector adapter for EMI filtering that is built to withstand 1000 volts RMS for one minute.

The Series 700 filtered connector adapter is designed to meet **Bellcore technical requirement NWT-001089 and FCC (Part 68 test)** specifications while providing superb EMI filtering performance out to 5 GHz.

## Applications

- High speed data transmission

## Features

- Capacitance values ranging from 100 pF to 830 pF
- Superior rugged mechanical construction
- Excellent core grounding through Spectrum Control's wider contact area

## Ordering Information

Capacitance Values	9 Pin	15 Pin	25 Pin
100 pF	56-705-202	56-715-202	56-725-202
375 pF	56-705-204	56-715-204	56-725-204
500 pF	56-705-205	56-715-205	56-725-205
830 pF	56-705-206	56-715-206	56-725-206

Minimum order quantity applies, call Spectrum Control for details.

## Insertion Loss Chart

Filter Circuits	Capacitance		3 dB Max Cut-off Frequency (MHz)	Working Voltage DC -55°C to +125°C	Minimum Insertion Loss - Decibels (dB)									
	Value	Tolerance			5 MHz	10 MHz	20 MHz	50 MHz	100 MHz	200 MHz	500 MHz	1 GHz	2 GHz	5 GHz
C	100 pF	±25%	53	200 V	—	—	—	—	1	6	14	19	25	35
	375 pF	±25%	23	200 V	—	—	—	4	10	16	22	24	30	40
	500 pF	±25%	20	200 V	—	—	2	7	13	19	25	27	33	43
	830 pF	±25%	6	200 V	—	2	6	12	18	24	30	33	39	50

For additional high voltage capabilities contact Spectrum Control.

## Typical Insertion Loss

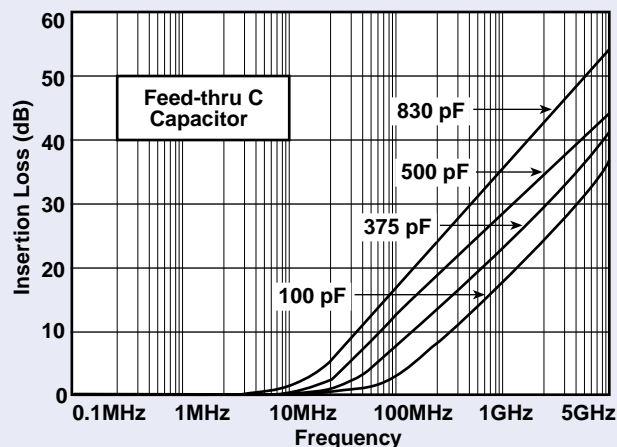

Above curves represent application of proper grounding fundamentals, for assistance consult with Spectrum Control.

Insertion loss measured per MIL-STD-220, no load, 50 ohm source and load.

## Mechanical Specifications

(Same as Series 700, see page 147)

Shell . . . . . Zinc diecast, nickel plated

Insulators . . . . . Glass filled polyester

Contacts . . . . . Copper alloy,  
Socket 30μ inch gold  
Pins 15μ inch gold

### Operating

Temperature . . . . . -55°C to +125°C

## Electrical Specifications

Rated Voltage . . . . . 200 VDC

### Current

Rating . . . . . 5 Amps

DC Resistance . . . . . 15 milliohm maximum

### Dielectric

### Withstanding

Voltage . . . . . 1000 VRMS (FCC Part 68 test)

# Waved Metal Gaskets



Proper mounting of an EMI filter is critical to achieving optimum filtering performance. For applications requiring very high attenuation, it is necessary to fill the gaps at the mounting surface-to-connector interface. The length of any gap must be short, relative to the wavelength of the signal to be attenuated. Spectrum Control supplies a line of "waved" gaskets. This design ensures the maximum "gap length" will not exceed the wave pitch, .200" (5.08mm), even on surfaces with poor flatness. This ensures maximum filter performance to 1GHz and beyond.

## Specifications

**Material** . . . . . Beryllium Copper, CA 172 (per QQ-C-533)

**Finish** . . . . . Electro tin plate, 100 micro inches (per MIL-T-10727)

**Material**

**Thickness** . . . . . .005" (.13mm) compressed

**Wave**

**Height** . . . . . .030"+.020/-0.015 (.76+.51/-0.38mm)

**Length increase**

**when flattened.** . . . . . 0.008" (.20mm) per inch

**Waved Metal Grounding/Shielding Gasket (shown in free state)**

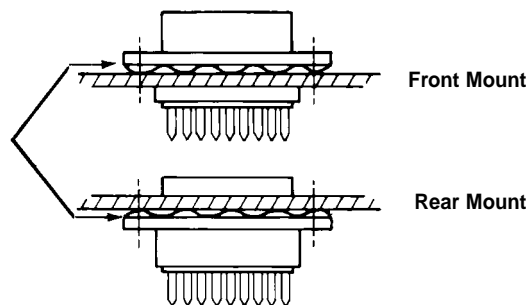

**Wave Height**



## Ordering Information Select part number by filling in "xxx": 572019-00xxx-70

**Mounting: Front mounted pin or socket connector, rear mounted pin connector.**

Shell Size	A ±.020 (0.51)	B ±.020 (0.51)	C ±.020 (0.51)	D ±.020 (0.51)	E ±.005 (0.13)	"xxx"
9	1.213 (30.81)	.984 (24.99)	.777 (19.74)	.600 (15.24)	.440 (11.18)	100
15	1.541 (39.14)	1.312 (33.32)	1.105 (28.07)	.600 (15.24)	.440 (11.18)	101
25	2.088 (53.04)	1.852 (47.04)	1.645 (41.78)	.600 (15.24)	.440 (11.18)	102
37	2.729 (69.32)	2.500 (63.50)	2.293 (58.24)	.600 (15.24)	.440 (11.18)	103
50	2.635 (66.93)	2.406 (61.11)	2.190 (55.63)	.710 (18.03)	.550 (13.97)	104

**Mounting: Rear mounted socket connectors only.**

Shell Size	A ±.020 (0.51)	B ±.020 (0.51)	C ±.020 (0.51)	D ±.020 (0.51)	E ±.005 (0.13)	F ±.005 (0.13)	G ±.020 (0.51)	"xxx"
9	1.213 (30.81)	.984 (24.99)	.450 (11.43)	.660 (16.76)	.324 (8.23)	.360 (9.14)	.600 (15.24)	105
15	1.541 (39.14)	1.312 (33.32)	.670 (17.02)	.988 (25.10)	.324 (8.23)	.360 (9.14)	.600 (15.24)	106
25	2.088 (53.04)	1.852 (47.04)	1.110 (28.19)	1.528 (38.81)	.324 (8.23)	.360 (9.14)	.600 (15.24)	107
37	2.729 (69.32)	2.500 (63.50)	1.550 (39.37)	2.176 (55.27)	.324 (8.23)	.360 (9.14)	.600 (15.24)	108
50	2.635 (66.93)	2.406 (61.11)	1.550 (39.37)	2.082 (52.88)	.436 (11.07)	.470 (11.94)	.710 (18.03)	109

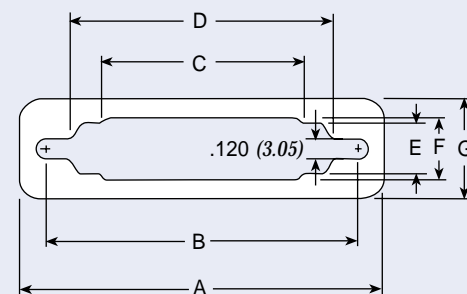
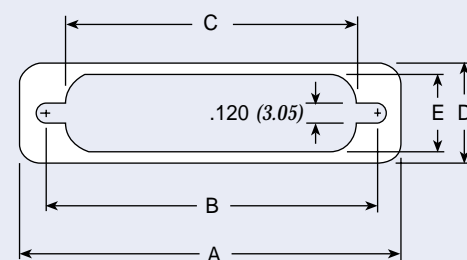

Dimensions in inches (mm)

# Hooded Strain Reliefs

Hooded strain reliefs are used whenever a connector is used on a cable assembly which will be exposed to users and subject to multiple disconnects. Hoods are designed to protect users from shock hazard by exposed solder joints, as well as provide a strain relief for the wires and protection against accidental short circuits.

Since most filter connectors are larger than standard connectors, there had been a problem fitting most commercially available hoods. Spectrum Control solves this problem. Our hoods are molded of thin wall plastic, providing extra internal space to accommodate larger filter connectors. The hood is constructed of extremely durable polycarbonate and meets the flammability requirements for UL94V-0.

In addition, hoods are ideal for use on applications which require the use of extra components such as resistors or varistors on the wires. The nonconductive hood conveniently houses the connector, components, and protects any joints.

- **2560-9000-XX** is supplied with metal retention clips to hold the connector within the hood assembly. This item is recommended for use with Spectrum Filtered D-sub's, most other filtered D-sub's, and most standard D-sub's.
- **2560-9001-XX** is meant to be used with a connector which has a special eyelet on the mounting flange. This feature is available as an option on the Spectrum Filtered D-sub. Contact factory for additional information.

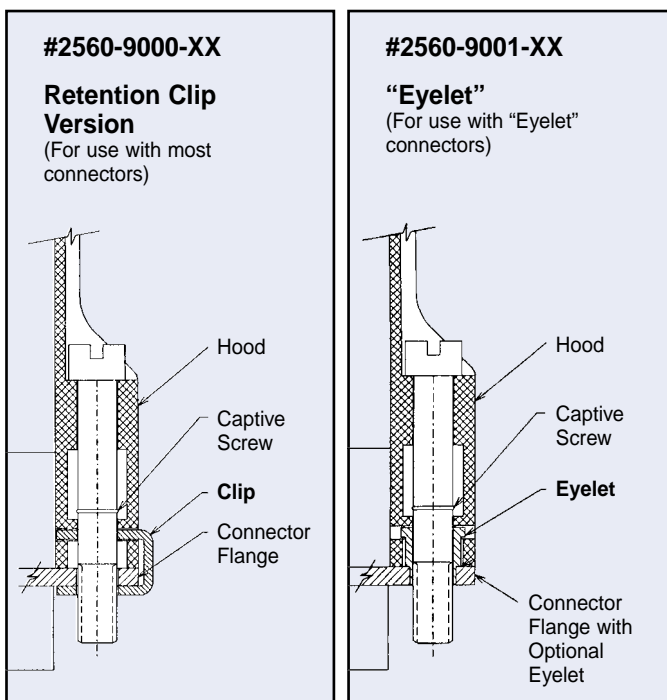

## Ordering Information and Dimensions

Part Number	Connector Size	A ±.005	B Max	C Max	D Max	E Max	F Max
2560-9000-01 2560-9001-01	9	0.984 (24.99)	1.228 (31.19)	1.710 (43.43)	0.985 (25.02)	.685 (17.40)	.240 (6.07)
2560-9000-02 2560-9001-02	15	1.312 (33.33)	1.556 (39.52)	1.710 (43.43)	1.310 (26.71)	.685 (17.40)	.300 (7.62)
2560-9000-03 2560-9001-03	25	1.852 (47.04)	2.103 (53.42)	1.710 (43.43)	1.850 (46.99)	.685 (17.40)	.400 (10.16)
2560-9000-04 2560-9001-04	37	2.500 (63.50)	2.744 (69.70)	1.710 (43.43)	2.500 (63.50)	.685 (17.40)	.400 (10.16)

Dimensions in inches (mm)

# Custom Engineered Solutions

Despite the breadth of our filtered connector product line, there exist certain applications which demand a custom EMC solution. Our engineering staff will work with your design team to provide a custom filtered connector which meets your individual requirements. Examples of custom projects are shown below.

## Special Mounting Flanges

- Housings can be designed to be integrated into the customer's equipment. The housings are constructed of machined materials, or precision diecast zinc.

## Value-added Assemblies

- Spectrum's capabilities extend beyond just supplying filter connectors. Additional operations such as sourcing and assembling flexible circuits, adding flying leads, or making connector to connector assemblies, all can be provided in conjunction with the filter connector.

## Custom Filter Arrangements

- Complex filters involving unbalanced Pi types, LC types with large inductive components, special pin-in to pin-out translations, and overvoltage protective devices such as diodes and varistors can be packaged within the connector.

## Other Connector Formats

- Manufacturer specific connectors also can be filtered. Our involvement ranges from complete design to implementing minor modifications to include the addition of the filter components. Medical equipment and hand-held devices are examples of excellent applications for these connectors.

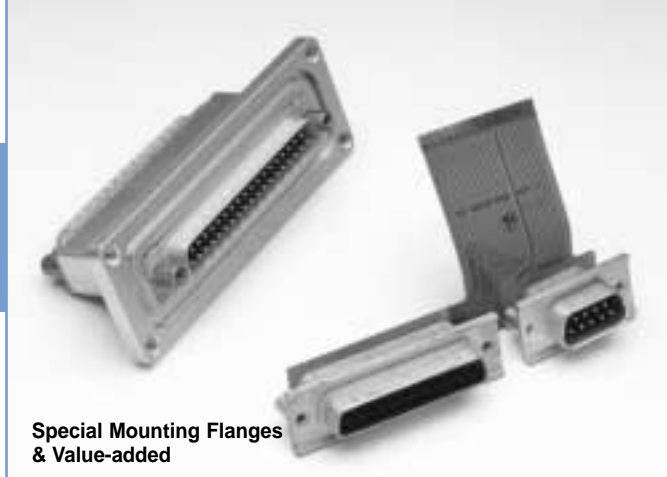

VDE RS232 connector



Tempest VGA connector adapter



FCC VGA connector adapter

# Filtered Connector Performance Specifications

The filtered D-subminiature connectors shown in this catalog have been designed and tested to the following test plan.

The information shown can be used as a basis for your filtered connector specifications. (Contact Spectrum Control for additional details.)

Test Group	Order of Test	Examination of Test	Test Method	Post Test Requirements
I	1	Visual and Mechanical Examination		In accordance with applicable requirements.
	2	Materials, Designs Construction and Workmanship		
	3	Physical Dimensions and Marking		
	4	Capacitance	MIL-STD-202 Method 305 1 KHz, 1VRMS max. 25°C	Within specified tolerance.
	5	Dielectric Withstanding Voltage	MIL-STD-202 Method 301	No breakdown or damage.
	6	Insulation Resistance	MIL-STD-202 Method 302, test condition at rated voltage	5000 megohm minimum.
	7	Insertion Loss	MIL-STD-220 No load	In accordance with applicable requirements.
II	1	Contact Engagement and Separation	MIL-C-24308, Para. 3.5.10	Maximum engagement force 18.0 oz., minimum separation force 0.7 oz.
	2	Mating and Unmating Force	MIL-C-24308, Para. 3.5.4	MIL-C-24308, Para. 3.5.4 Table II Limits: Shell size 1-5, class G only.
	3	Durability	MIL-C-24308, Para. 3.5.16, 4.7.17, except 100 cycles	MIL-C-24308, Para. 3.5.9 Contact resistance at 1 amp. 20 milliohms max.
	4	Thermal Shock	MIL-STD-202 Method 107, Test condition B, -55°C to +125°C	No evidence of damage. Insulation resistance not less than 2500 megohms.
	5	Solderability	MIL-STD-202; Method 208, RMA-Flux	Terminals shall meet solderability requirements.
	6	Moisture Resistance	MIL-STD-202 Method 106, less step seven	Insulation resistance not less than 500 megohms. Meet dielectric withstanding voltage requirements.
	7	Resistance to Soldering Heat	MIL-STD-202 Method 210, Test condition D	Insulation resistance not less than 500 megohms. Meet dielectric withstanding voltage requirements.
III	1	Vibration	MIL-STD-202 Method 204, Test condition D, 100 mA, current	No interruption of current flow longer than 1 microsecond. Insulation resistance greater than 5000 megohms.
	2	Shock	MIL-STD-202 Method 213. Test Condition G, 100 mA, current	No interruptions of current flow longer than 1 microsecond.
				Contact resistance at 1 amp. 15 milliohms max.
				Capacitance within specified limits.
3	Mounting Inserts a. Prevailing torque (locking) b. Installation torque (locking) c. Push-out Force	IFI-100	a. 3 inch-pounds max. b. 6 inch-pounds without damage c. 10 pounds axial force without loosening insert	
IV	1	Life	MIL-STD-202 Method 108, Test condition D, within 125% of rated voltage at the maximum operating temperature.	Filter shall meet all initial requirements except insulation resistance shall not be less than 500 megohms.

# Board & Panel Cutouts

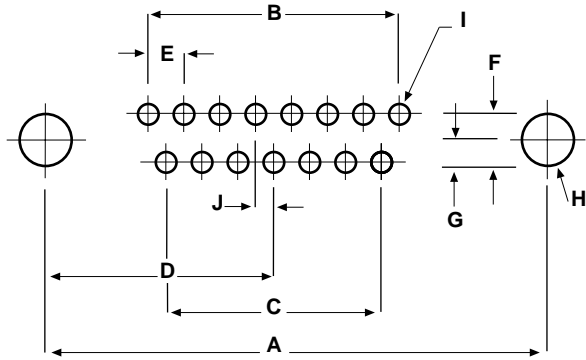

Printed Circuit  
Board Mount (standard density)

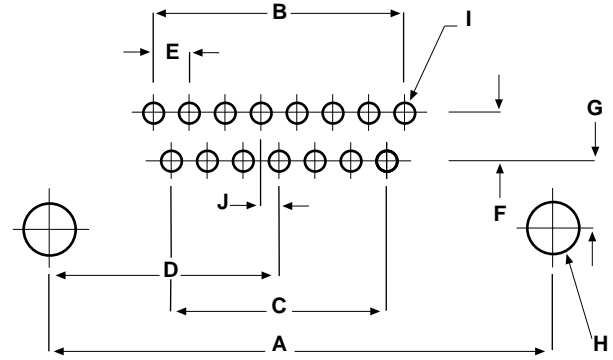

Printed Circuit  
Right Angle Mount (standard density)

## Board Layout (Pin and Socket Contact) for Standard D-Sub Connectors

Shell Size	A	B	C	D	E	F	G	H	I (Dia.)	J
9	.984 (25.00)	.436 = 4 x .109 (11.07) (2.77)	.327 = 3 x .109 (8.31) (2.77)	.492 (12.50)						
15	1.312 (33.32)	.763 = 7 x .109 (19.38) (2.77)	.654 = 6 x .109 (16.61) (2.77)	.656 (16.66)						
25	1.852 (47.04)	1.308 = 12 x .109 (33.22) (2.77)	1.199 = 11 x .109 (30.45) (2.77)	.926 (23.52)	.109 (2.77)	.112 (2.84)	.058 (1.42)	.125 (3.18)	.045 (1.14)	.054 (1.37)
37	2.500 (63.50)	1.962 = 18 x .109 (49.83) (2.77)	1.853 = 17 x .109 (47.07) (2.77)	1.250 (31.75)						
50	2.406 (61.11)	1.744 = 16 x .109 (44.30) (2.77) 2 rows	1.635 = 15 x .109 (41.35) (2.77)	1.203 (30.56)						

## Panel Cutouts (Front or Rear Mounting) for Standard and Hi-Density D-Sub Connectors

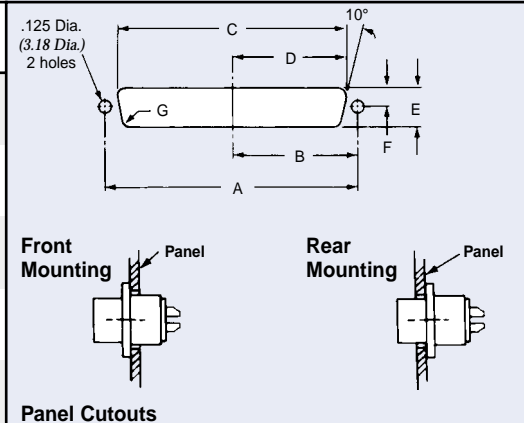
Shell Size	A ±.015 (.38)	B ±.015 (.38)	C ±.015 (.38)	D ±.015 (.38)	E ±.003 (.08)	F ±.005 (.13)	G ±.002 (.05)	Panel Cutouts
9	.984 (24.99)	.492 (12.49)	.777 (19.74)	.388 (9.87)	.440 (11.18)	.220 (5.59)	.150 (3.81)	
15	1.312 (33.32)	.656 (16.66)	1.105 (28.07)	.552 (14.03)	.440 (11.18)	.220 (5.59)	.150 (3.81)	
25	1.852 (47.04)	.926 (23.52)	1.645 (41.78)	.822 (20.89)	.440 (11.18)	.220 (5.59)	.150 (3.81)	
37	2.500 (63.50)	1.250 (31.75)	2.293 (58.24)	1.146 (29.12)	.440 (11.18)	.220 (5.59)	.150 (3.81)	
50	2.406 (61.11)	1.203 (30.55)	2.190 (55.63)	1.095 (27.81)	.550 (13.97)	.275 (6.98)	.150 (3.81)	

Dimensions in inches (mm)

# Filtered Connector Performance Specifications

**15 Hi-Density Pin/PCB**

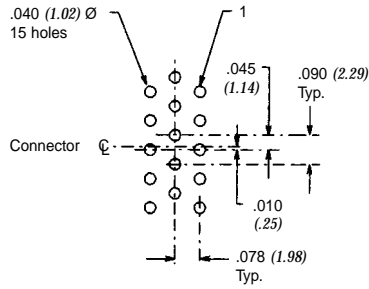

**15 Hi-Density Socket/Right Angle**

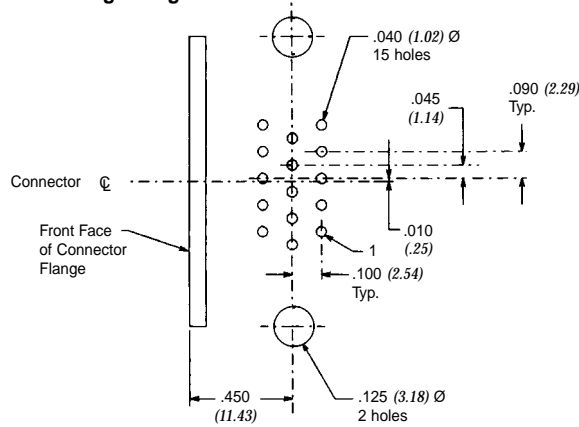

**26 Hi-Density Pin/PCB**

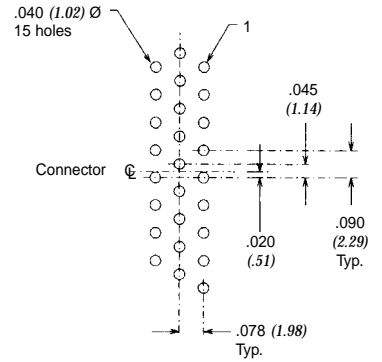

**26 Hi-Density Socket/PCB**

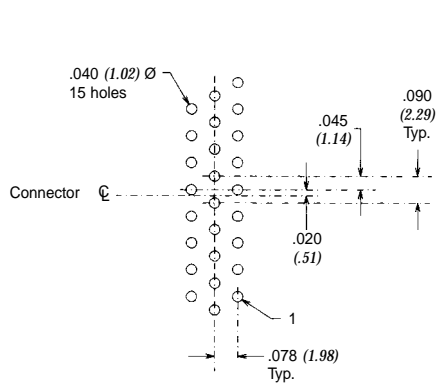

**44 Hi-Density Pin/PCB**

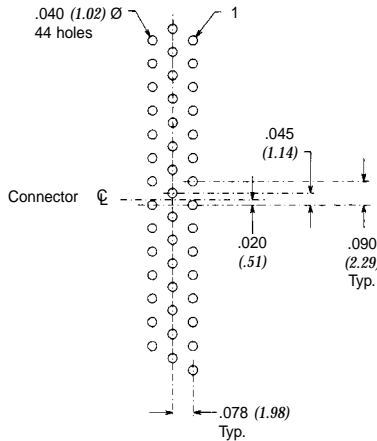

**44 Hi-Density Socket/PCB**

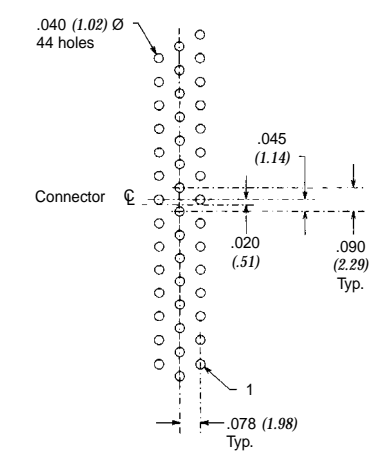

**62 Hi-Density Pin/PCB**

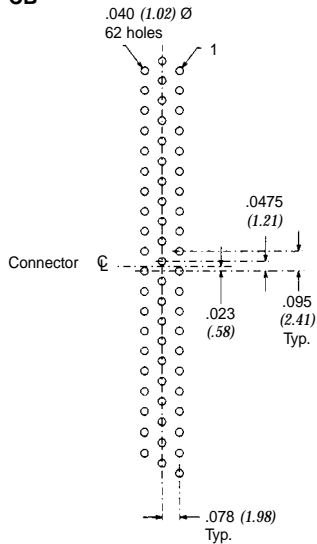

**62 Hi-Density Socket/PCB**

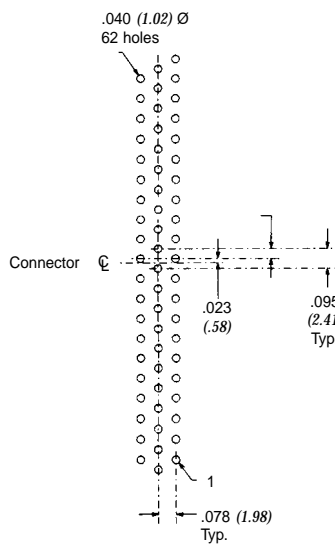

**78 Hi-Density Socket/PCB Pin/PCB**

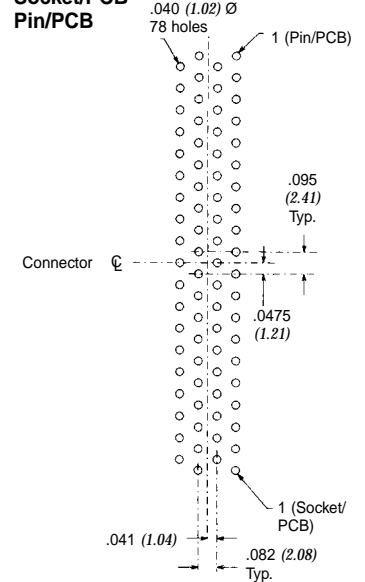

Dimensions in inches (mm)

Filtered Connectors

# Custom Filtered Connectors MIL and High Reliability

Spectrum Control offers a premium line of custom and specialty filtered connectors. These custom high reliability, circular, rack and panel and ARINC connectors have a reputation for superior quality and performance. Several types of filtering are available (See figure at right).

## EMI Filter Performance

The performance indicated in this table are examples for design guidelines. Insertion values are per MIL-STD-220 (No Load).

## Resistance

Insulation Resistance . . . . . 5 Gigohm min.  
D.C. Resistance . . . . . 30 Milliohm max.

Figure A (1)

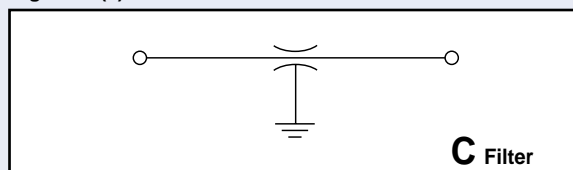

Figure B (2)

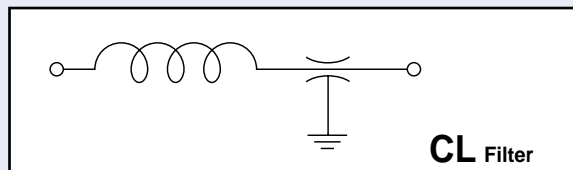

Figure C (3)

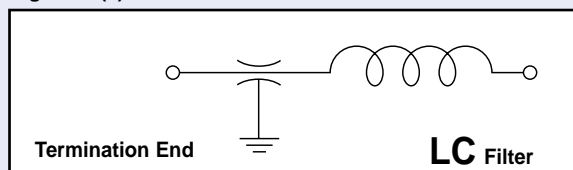
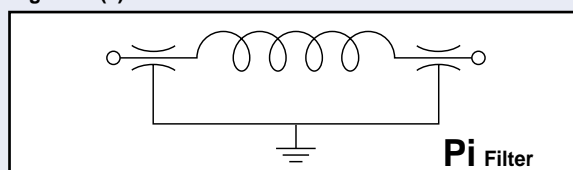

Figure D (4)



## Electrical Characteristics

Capacitance (pF, GMV)	Working Voltage		DWV (VOC)	Minimum Insertion Loss (dB)																	
	DC 85°C	AC 85°C		Figure A					Figure B & C					Figure D							
				Cut-Off Freq. (MHz)	1 MHz	10 MHz	100 MHz	500 MHz	1000 MHz	Cut-Off Freq. (MHz)	1 MHz	10 MHz	100 MHz	500 MHz	1000 MHz	Cut-Off Freq. (MHz)	1 MHz	10 MHz	100 MHz	500 MHz	1000 MHz
1,000	200	115	500	5	—	4	21	34	39	5	—	5	23	36	42	5	—	4	28	54	65
2,000	200	115	500	1	—	9	26	39	44	1	—	10	29	42	47	1	—	8	39	65	70
3,000	200	115	500	1	—	12	30	43	48	1	—	13	36	45	51	1	—	11	47	70	70
5,000	200	115	500	1	1	16	34	46	52	1	1	17	37	49	54	1	1	14	54	70	70
7,000	200	115	500	1	3	19	37	49	55	1	3	20	39	52	57	1	3	18	60	70	70
10,000	200	115	500	1	4	21	39	52	57	1	4	22	41	54	60	1	4	22	64	70	70
20,000	100	—	250	.50	9	26	44	57	62	.50	9	28	47	60	65	.50	9	33	70	70	70

Consult Spectrum Control for availability of alternative capacitance values.

# Compact Shell Filtered Connectors

## MIL-C-38999 Filtered Connector, Compact Shell

This design is for the MIL-C-38999 connector series I, II, and III. The shell is constructed out of a single piece of metal and contains planar capacitors. **The dimensions are the same as the unfiltered MIL qualified connector.**

The compact shell filtered connectors offer designers an effective filtering device that reduces the amount of real estate required within a product enclosure. These connectors are available with mixed capacitance filtered lines within the connector as well as insulated and/or grounded lines. Some capacitance levels may not be available in all connector sizes. Please consult factory for specific applications.

Compact shell filtered connectors provide a simple and space-efficient solution to a complex EMI problem. More detailed information on compact shell connectors is located on pages 200-205.



### Advantages of Spectrum's Compact Shell Design

#### ■ Easy retrofit or upgrade

Our compact shell connector is the only MIL filtered connector which is the same size as an unfiltered connector . . . allowing for easy retrofit or upgrade without concerns for space availability.

#### ■ Weight and space savings

Smaller physical size is ideal for many applications, especially airborne.

#### ■ Reduced cost and lead times

Standardized design for most contact arrangements minimizes tooling required (often none) . . . reducing procurement costs and facilitating small order quantities or prototypes.

#### ■ Design flexibility and quality assurance

We are vertically integrated for ceramic filter capacitors, enabling us to offer a broad selection of this critical component and ensuring design versatility and manufacturing control.

#### ■ Custom designs

Optimize your system performance with a custom designed filtered connector.

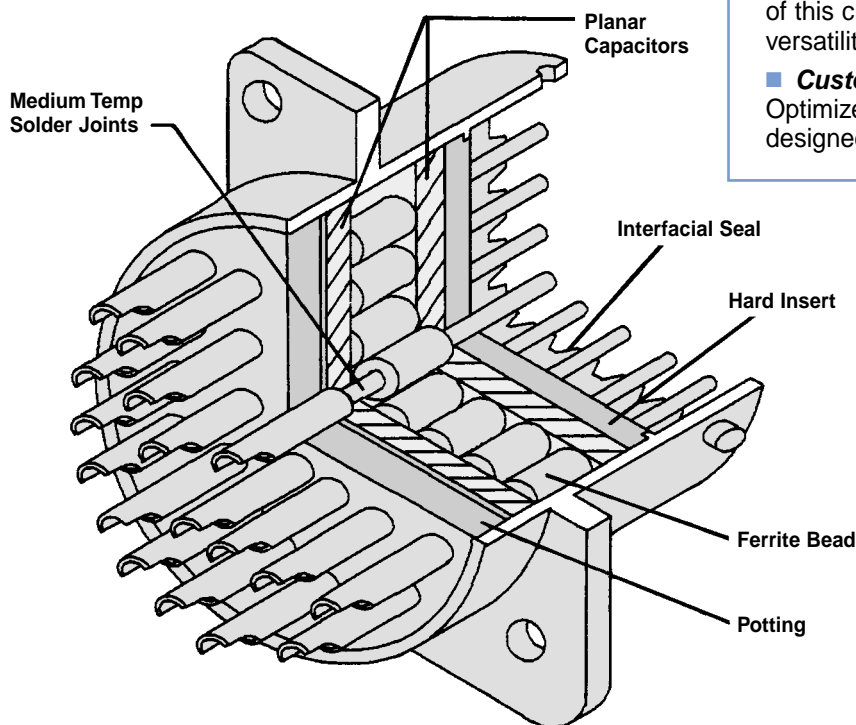

For extended shell tubular design, see page 206.

# MIL-C-38999, Compact Shell

## Ordering Information

The many benefits of using Spectrum's compact shell design are detailed on page 199. Review the benefits and specifications provided to determine if these space saving connectors will fulfill your requirements.

Available connector styles and shell sizes for this MIL series are shown on the following pages. Refer to these pages and the information below to develop your connector part number.

## Materials and Finishes

Shell . . . . . As noted in Ordering Information  
 Contacts . . . . . Copper Alloy, Gold Plate per MIL-G-45204  
 Seals . . . . . Elastomer, Silicone  
 Insulator . . . . . High Grade Plastic  
*(For electrical specifications, see page 198.)*

<p><b>9</b></p> <p><b>Filtered Connector MIL Indicator</b> 9-MIL-C-38999 Compact Shell</p> <p><b>Series Indicator</b> A-Series I B-Series II C-Series III</p> <p><b>Shell Style</b> 1- Wall Mount Receptacle (Front Panel Mounting) 2- Box Mount Receptacle Series I&amp;II (Front Panel Mounting) 3- Jam Nut Receptacle 4- Wall Mount Receptacle Series I&amp;II (Back Panel Mounting) 5- Box Mount Receptacle Series I&amp;II (Back Panel Mounting)</p>	<p><b>A</b></p> <p><b>Finish</b> B- Aluminum Olive Drab Cadmium E- Stainless Steel Passivated F- Aluminum, Electroless Nickel</p> <p><b>Shell Size</b> Series I&amp;III 9, 11, 13, 15, 17, 19, 21, 23, &amp; 25 Series II 8, 10, 12, 14, 16, 18, 20, 22, &amp; 24</p>	<p><b>2</b></p> <p><b>11</b></p> <p><b>35</b></p> <p><b>Contact Arrangement</b> See Below (last two digits of each number)</p> <p><b>Contact/Termination Type</b> P- Pin/PC Tail S- Pin/Solder Cup B- Socket/PC Tail N- Socket/Crimp Removable</p>	<p><b>S</b></p> <p><b>Alternate Shell Position</b> N- (Normal) A, B, C, D E- Series III only</p> <p><b>Filter Schematic</b> 1- "C" Feed-thru 2- "CL" 3- "LC" 4- "PI"</p>	<p><b>4</b></p> <p><b>Filter Capacitance</b> Specify by using EIA codes. Two significant digits plus number of zeros. 102 = 1000pF 401 = 400pF</p>	<p><b>102</b></p> <p><b>Capacitance Tolerance</b> M = ± 20% P = -0% +100% (GMV)</p>	<p><b>M</b></p>
---	---	--	--	--	---	-----------------

**Custom Part Ordering Note:**  
For Filtered Connectors with custom requirements, such as mixed capacitance, insulated lines, ground lines or an unlisted contact arrangement, consult factory for specific part numbers.

## Contact Arrangements (First two digits shell size, second two contact arrangement)

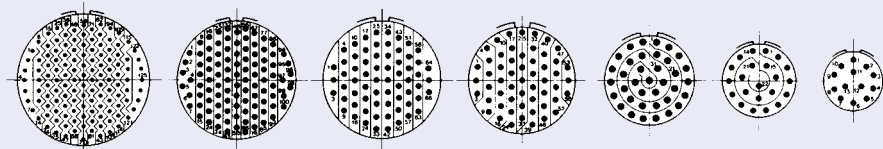
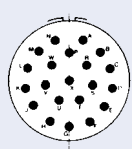
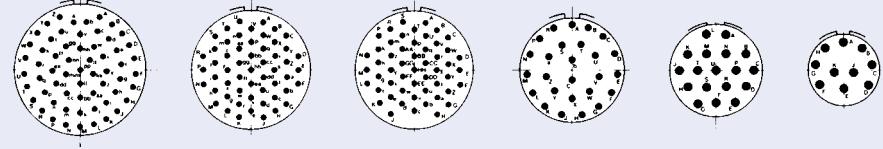
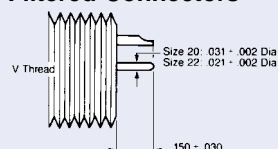
<p><b>#22 Contacts – 5 Amps</b></p>  <p>2535 128 #22    2335 100 #22    1935 66 #22    1735 55 #22    1535 37 #22    1335 22 #22    1135 13 #22</p>	<p><b>#16 Contacts – 13 Amps</b></p>  <p>2321 21 #16</p>
<p><b>#20 Contacts – 7.5 Amps</b></p>  <p>2561 61 #20    2355 55 #20    2353 53 #20    1726 26 #20    1518 18 #20    1398 10 #20</p>	<p><b>Standard Termination available in all Filtered Connectors</b></p> 

Filtered Connectors

# MIL-C-38999, Compact Shell Series I



## MS27466 Wall Mount, Front Panel Mounting

Shell Size	A Dia.	M	H Dia.	K	R	T	V Thread UNEF-2A
9	.572 (14.55)	.632 (16.07)	.128 (3.26)	.085 (2.16)	.719 (18.28)	.938 (23.85)	.4375-18
11	.700 (17.80)	.632 (16.07)	.128 (3.26)	.085 (2.16)	.812 (20.65)	1.031 (26.22)	.5625-24
13	.850 (21.62)	.632 (16.07)	.128 (3.26)	.085 (2.16)	.906 (23.04)	1.125 (28.61)	.6875-24
15	.975 (24.79)	.632 (16.07)	.128 (3.26)	.085 (2.16)	.969 (24.64)	1.219 (31.00)	.8125-20
17	1.100 (27.97)	.632 (16.07)	.128 (3.26)	.085 (2.16)	1.062 (27.01)	1.312 (33.36)	.9375-20
19	1.207 (30.69)	.632 (16.07)	.128 (3.26)	.085 (2.16)	1.156 (29.40)	1.438 (36.51)	1.0625-18
21	1.332 (33.87)	.602 (15.31)	.128 (3.26)	.115 (2.92)	1.250 (31.79)	1.562 (39.72)	1.1875-18
23	1.475 (37.46)	.602 (15.31)	.147 (3.74)	.115 (2.92)	1.375 (34.97)	1.688 (42.93)	1.3125-18
25	1.582 (40.23)	.602 (15.31)	.147 (3.74)	.115 (2.92)	1.500 (38.15)	1.812 (46.08)	1.4375-18

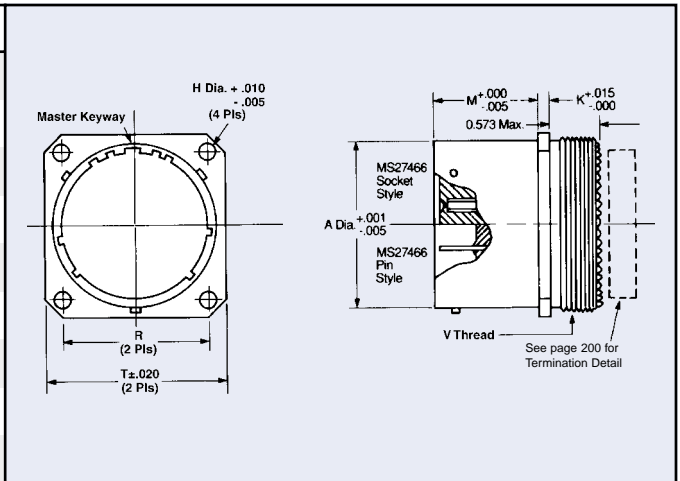

## MS27496 Box Mount, Front Panel Mounting

Shell Size	A Dia	M	K	X Dia.	H Dia.	R	T
9	.572 (14.55)	.632 (16.07)	.085 (2.16)	.469 (11.93)	.128 (3.26)	.719 (18.28)	.938 (23.85)
11	.700 (17.80)	.632 (16.07)	.085 (2.16)	.594 (15.11)	.128 (3.26)	.812 (20.65)	1.031 (26.22)
13	.850 (21.62)	.632 (16.07)	.085 (2.16)	.719 (18.28)	.128 (3.26)	.906 (23.04)	1.125 (28.61)
15	.975 (24.79)	.632 (16.07)	.085 (2.16)	.844 (21.46)	.128 (3.26)	.969 (24.64)	1.219 (31.00)
17	1.100 (27.97)	.632 (16.07)	.085 (2.16)	.969 (24.64)	.128 (3.26)	1.062 (27.01)	1.312 (33.36)
19	1.207 (30.69)	.632 (16.07)	.085 (2.16)	1.078 (27.41)	.128 (3.26)	1.156 (29.40)	1.438 (36.57)
21	1.332 (33.87)	.602 (15.31)	.115 (2.92)	1.203 (30.59)	.128 (3.26)	1.250 (31.79)	1.562 (39.72)
23	1.457 (36.96)	.602 (15.31)	.115 (2.92)	1.328 (33.77)	.147 (3.74)	1.375 (34.97)	1.688 (42.93)
25	1.582 (40.23)	.602 (15.31)	.115 (2.92)	1.453 (36.95)	.147 (3.74)	1.500 (38.15)	1.812 (46.08)

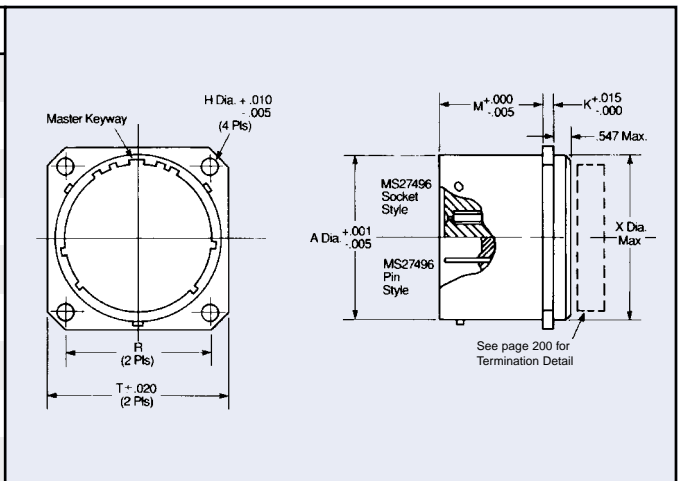

Dimensions in inches (mm)

# MIL-C-38999, Compact Shell Series I

## MS27468 Jam Nut

Shell Size	V Thread UNEF-2A	F Dia.	S	Q Dia.	W
9	.4375-28	1.188 (30.21)	1.062 (27.01)	.655 (16.66)	.109 (2.77)
11	.5625-24	1.375 (34.97)	1.250 (31.79)	.755 (19.20)	.109 (2.77)
13	.6875-24	1.500 (38.15)	1.375 (34.97)	.942 (23.96)	.109 (2.77)
15	.8125-20	1.625 (41.32)	1.500 (38.15)	1.066 (27.11)	.109 (2.77)
17	.9375-20	1.750 (44.50)	1.625 (41.32)	1.191 (30.29)	.109 (2.77)
19	1.0625-18	1.938 (49.28)	1.812 (46.08)	1.316 (33.47)	.140 (3.56)
21	1.1875-18	2.062 (52.44)	1.938 (49.28)	1.441 (36.64)	.140 (3.56)
23	1.3125-18	2.188 (55.64)	2.062 (52.44)	1.566 (39.82)	.140 (3.56)
25	1.4375-18	2.312 (58.79)	2.188 (55.64)	1.691 (43.00)	.140 (3.56)

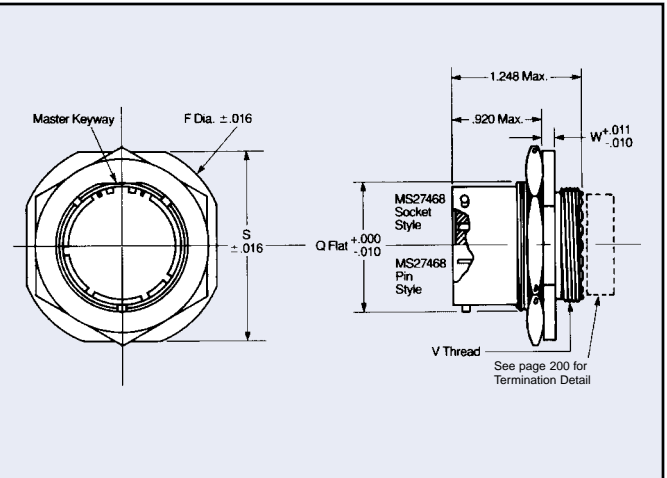

## MS27656 Wall Mount, Back Panel Mounting

Shell Size	A Dia.	M	K	L	H Dia.	R	T	V Thread UNEF-2A
9	.572 (14.55)	.820 (20.85)	.085 (2.16)	.469 (11.93)	.128 (3.25)	.719 (18.25)	.938 (23.85)	.4375-28
11	.700 (17.80)	.820 (20.85)	.085 (2.16)	.469 (11.93)	.128 (3.25)	.812 (20.65)	1.031 (26.22)	.5625-24
13	.850 (21.62)	.820 (20.85)	.085 (2.16)	.469 (11.93)	.128 (3.25)	.906 (23.04)	1.125 (28.61)	.6875-24
15	.975 (24.79)	.820 (20.85)	.085 (2.16)	.469 (11.93)	.128 (3.25)	.969 (24.64)	1.219 (31.00)	.8125-20
17	1.100 (27.97)	.820 (20.85)	.085 (2.16)	.469 (11.93)	.128 (3.25)	1.062 (27.01)	1.312 (33.36)	.9375-20
19	1.207 (30.69)	.820 (20.85)	.085 (2.16)	.469 (11.93)	.128 (3.25)	1.156 (29.40)	1.438 (36.57)	1.0625-18
21	1.332 (33.87)	.790 (20.09)	.115 (2.92)	.500 (12.72)	.128 (3.25)	1.250 (31.79)	1.562 (39.72)	1.1875-18
23	1.457 (37.05)	.790 (20.09)	.115 (2.92)	.500 (12.72)	.147 (3.74)	1.375 (34.97)	1.688 (42.93)	1.3125-18
25	1.582 (40.23)	.790 (20.09)	.115 (2.92)	.500 (12.72)	.147 (3.74)	1.500 (38.15)	1.812 (46.08)	1.4375-18

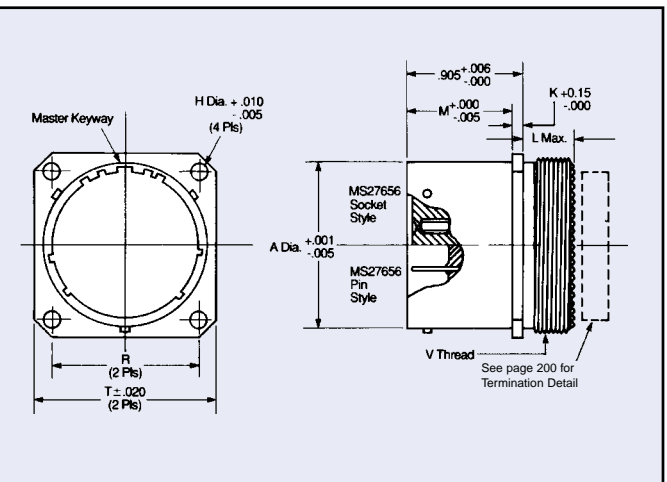

## MS27505 Box Mount, Back Panel Mounting

Shell Size	A Dia.	M	K	L	X Dia.	H Dia.	R	T
9	.572 (14.55)	.820 (20.85)	.085 (2.16)	.469 (11.93)	.547 (13.91)	.128 (3.25)	.719 (18.28)	.938 (23.85)
11	.700 (17.80)	.820 (20.85)	.085 (2.16)	.469 (11.93)	.656 (16.68)	.128 (3.25)	.812 (20.65)	1.031 (26.22)
13	.850 (21.62)	.820 (20.85)	.085 (2.16)	.469 (11.93)	.828 (21.06)	.128 (3.25)	.906 (23.04)	1.125 (28.61)
15	.975 (24.79)	.820 (20.85)	.085 (2.16)	.469 (11.93)	.953 (24.23)	.128 (3.25)	.969 (24.64)	1.219 (31.00)
17	1.100 (27.97)	.820 (20.85)	.085 (2.16)	.469 (11.93)	1.078 (27.41)	.128 (3.25)	1.062 (27.01)	1.312 (33.36)
19	1.207 (30.69)	.820 (20.85)	.085 (2.16)	.469 (11.93)	1.203 (30.59)	.128 (3.25)	1.156 (29.40)	1.438 (36.57)
21	1.332 (33.87)	.790 (20.09)	.115 (2.92)	.500 (12.72)	1.328 (33.77)	.128 (3.25)	1.250 (31.79)	1.562 (39.72)
23	1.457 (37.05)	.790 (20.09)	.115 (2.92)	.500 (12.72)	1.453 (36.95)	.147 (3.74)	1.375 (34.97)	1.688 (42.93)
25	1.582 (40.23)	.790 (20.09)	.115 (2.92)	.500 (12.72)	1.578 (40.13)	.147 (3.74)	1.500 (38.15)	1.812 (46.08)

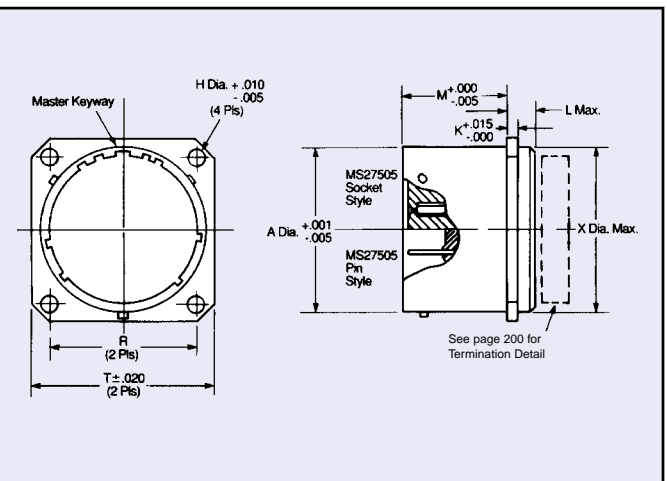

Dimensions in inches (mm)

# MIL-C-38999, Compact Shell Series II



## MS27508 Box Mount, Back Panel Mounting

Shell Size	A Dia.	AB Dia.	R BSC	T Dia.	S
8	.473 (12.03)	.547 (13.91)	.297 (7.55)	.120 (3.05)	.828 (21.06)
10	.590 (15.00)	.672 (17.09)	.3595 (9.14)	.120 (3.05)	.954 (24.26)
12	.750 (19.07)	.844 (21.46)	.406 (10.32)	.120 (3.05)	1.047 (26.63)
14	.875 (22.25)	.969 (24.64)	.453 (11.52)	.120 (3.05)	1.141 (29.02)
16	1.000 (25.43)	1.094 (27.82)	.4845 (12.32)	.120 (3.05)	1.234 (31.38)
18	1.125 (28.61)	1.219 (31.00)	.531 (13.50)	.120 (3.05)	1.328 (33.77)
20	1.250 (31.79)	1.344 (34.18)	.578 (14.70)	.120 (3.05)	1.453 (36.95)
22	1.375 (34.97)	1.469 (37.36)	.625 (15.89)	.120 (3.05)	1.578 (40.13)
24	1.500 (38.15)	1.594 (40.54)	.6875 (17.48)	.147 (3.74)	1.703 (43.31)

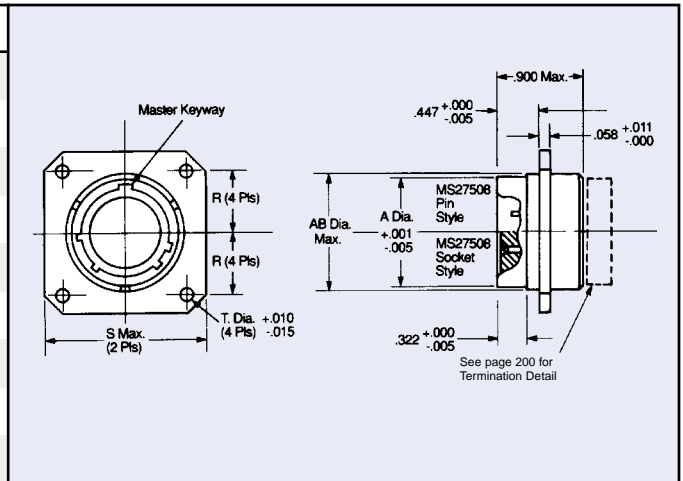

## MS27497 Wall Mount, Back Panel Mounting

Shell Size	A Dia.	AB Dia.	R BSC	T Dia.	S	V Thread UNEF-2A
8	.473 (12.03)	.547 (13.91)	.297 (7.55)	.120 (3.05)	.828 (21.06)	.4375-28
10	.590 (15.00)	.672 (17.09)	.3595 (9.14)	.120 (3.05)	.954 (24.26)	.5625-24
12	.750 (19.07)	.844 (21.46)	.406 (10.32)	.120 (3.05)	1.047 (26.63)	.6875-24
14	.875 (22.25)	.969 (24.64)	.453 (11.52)	.120 (3.05)	1.141 (29.02)	.8125-20
16	1.000 (25.43)	1.094 (27.82)	.4845 (12.32)	.120 (3.05)	1.234 (33.77)	.9375-20
18	1.125 (28.61)	1.219 (31.00)	.531 (13.50)	.120 (3.05)	1.328 (36.95)	1.0625-18
20	1.250 (31.79)	1.344 (34.18)	.578 (14.70)	.120 (3.05)	1.453 (36.95)	1.1875-18
22	1.375 (34.97)	1.469 (37.36)	.625 (15.89)	.120 (3.05)	1.578 (40.13)	1.3125-18
24	1.500 (38.15)	1.594 (40.54)	.6875 (17.48)	.147 (3.74)	1.703 (43.31)	1.4375-18

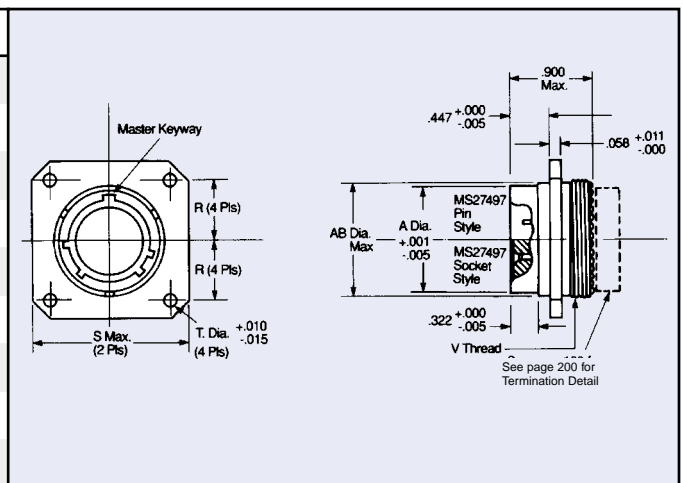

Dimensions in inches (mm)

# MIL-C-38999, Compact Shell Series II

## MS27472 Wall Mount, Front Panel Mounting

Shell Size	A Dia.	R BSC	T Dia.	S	V Thread UNEF-2A
8	.473 (12.03)	.297 (7.55)	.120 (3.05)	.828 (21.06)	.4375-28
10	.590 (15.00)	.3595 (9.14)	.120 (3.05)	.954 (24.26)	.5625-24
12	.750 (19.07)	.406 (10.32)	.120 (3.05)	1.047 (26.63)	.6875-24
14	.875 (22.25)	.453 (11.52)	.120 (3.05)	1.141 (29.02)	.8125-20
16	1.000 (25.43)	.4845 (12.32)	.120 (3.05)	1.234 (31.38)	.9375-20
18	1.125 (28.61)	.531 (13.50)	.120 (3.05)	1.328 (33.77)	1.0625-18
20	1.250 (31.79)	.578 (14.70)	.120 (3.05)	1.453 (36.95)	1.3125-18
22	1.375 (34.97)	.625 (15.98)	.120 (3.05)	1.578 (40.13)	1.3125-18
24	1.500 (38.15)	.6875 (17.48)	.147 (3.74)	1.703 (43.31)	1.4375-18

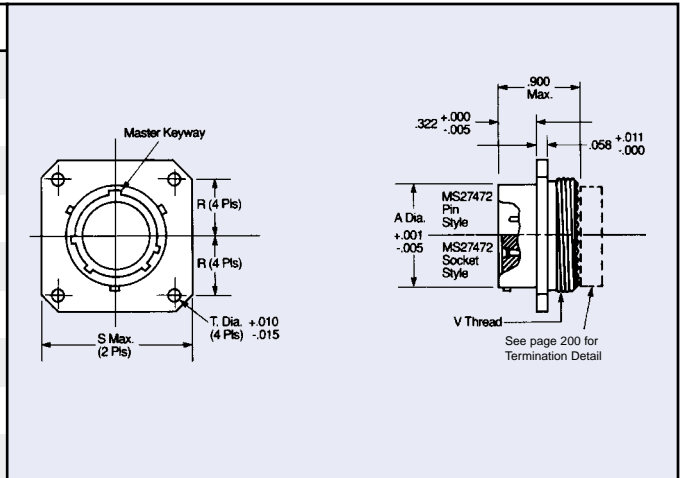

## MS27499 Box Mount, Front Panel Mounting

Shell Size	A Dia.	R BSC	T Dia.	S
8	.473 (12.03)	.297 (7.55)	.120 (3.05)	.828 (21.06)
10	.590 (15.00)	.3595 (9.14)	.120 (3.05)	.954 (24.26)
12	.750 (19.07)	.406 (10.32)	.120 (3.05)	1.047 (26.63)
14	.875 (22.25)	.453 (11.52)	.120 (3.05)	1.141 (29.02)
16	1.000 (25.43)	.4845 (12.32)	.120 (3.05)	1.234 (31.38)
18	1.125 (28.61)	.531 (13.50)	.120 (3.05)	1.328 (33.77)
20	1.250 (31.79)	.578 (14.70)	.120 (3.05)	1.453 (36.95)
22	1.375 (34.97)	.625 (15.89)	.120 (3.05)	1.578 (40.13)
24	1.500 (38.15)	.6875 (17.48)	.147 (3.74)	1.703 (43.31)

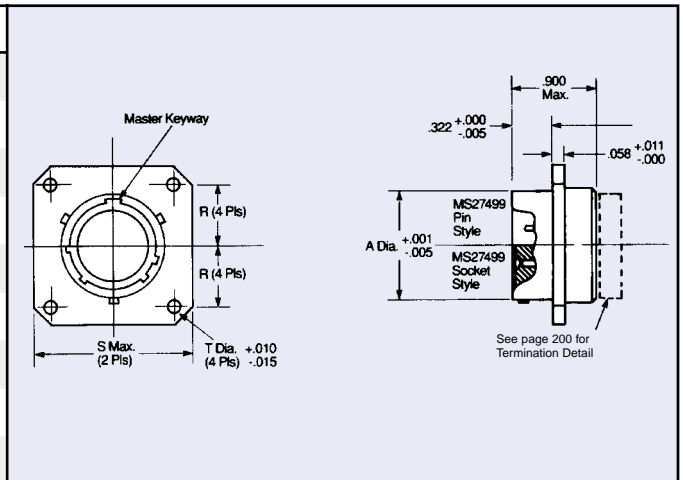

## MS27474 Jam Nut

Shell Size	V Thread Size	UNEF-2A Mod (Plated) Major Dia. Mod	A Dia.	F	Q Dia.	S
8	.4375-28	.421-.417	.473 (12.03)	.438 (11.14)	1.375 (34.97)	1.250 (31.79)
10	.5625-24	.542-.538	.590 (15.00)	.438 (11.14)	1.500 (38.15)	1.375 (34.97)
12	.6875-24	.667-.663	.750 (19.07)	.438 (11.14)	1.625 (41.35)	1.500 (38.15)
14	.8125-20	.791-.787	.875 (22.25)	.438 (11.14)	1.750 (44.50)	1.625 (41.35)
16	.9375-20	.916-.912	1.000 (25.43)	.438 (11.14)	1.938 (49.28)	1.781 (45.29)
18	1.0625-18	1.034-1.030	1.125 (28.61)	.438 (11.14)	2.016 (51.27)	1.890 (48.06)
20	1.1875-18	1.158-1.154	1.250 (31.79)	.464 (11.80)	2.141 (54.45)	2.016 (51.27)
22	1.3125-18	1.283-1.279	1.375 (34.97)	.464 (11.80)	2.265 (57.60)	2.140 (54.42)
24	1.4375-18	1.408-1.404	1.500 (38.15)	.464 (11.80)	2.390 (60.78)	2.265 (57.60)

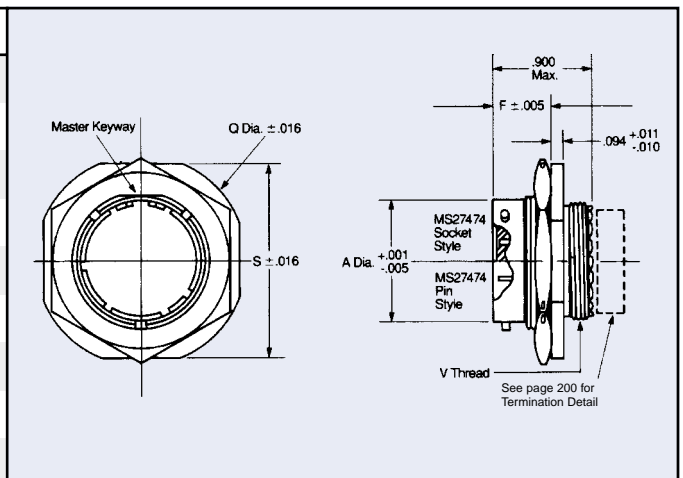

Dimensions in inches (mm)

# MIL-C-38999, Compact Shell Series III



## D38999/20 Wall Mount

Shell Size	V Thread	F	R	T	S	P	Q	W
9	M12 x 1.0-6g-0.100R	.823 (20.93)	.719 (18.28)	.594 (15.11)	.937 (23.83)	.128 (3.25)	.216 (5.49)	.098 (2.49)
11	M15 x 1.0-6g-0.100R	.823 (20.93)	.812 (20.15)	.719 (18.28)	1.031 (26.22)	.128 (3.25)	.194 (4.93)	.098 (2.49)
13	M18 x 1.0-6g-0.100R	.823 (20.93)	.906 (23.04)	.812 (20.65)	1.126 (28.63)	.128 (3.25)	.194 (4.93)	.098 (2.49)
15	M22 x 1.0-6g-0.100R	.823 (20.93)	.969 (24.64)	.906 (23.04)	1.220 (31.02)	.128 (3.25)	.173 (4.40)	.098 (2.49)
17	M25 x 1.0-6g-0.100R	.823 (20.93)	1.062 (27.01)	.969 (24.64)	1.311 (33.34)	.128 (3.25)	.194 (4.93)	.098 (2.49)
19	M28 x 1.0-6g-0.100R	.823 (20.93)	1.156 (29.40)	1.062 (27.01)	1.437 (36.54)	.128 (3.25)	.194 (4.93)	.098 (2.49)
21	M31 x 1.0-6g-0.100R	.791 (20.12)	1.250 (31.79)	1.156 (29.40)	1.563 (39.75)	.128 (3.25)	.194 (4.93)	.126 (3.20)
23	M34 x 1.0-6g-0.100R	.791 (20.12)	1.375 (34.97)	1.250 (31.79)	1.689 (42.95)	.154 (3.92)	.242 (6.15)	.126 (3.20)
25	M37 x 1.0-6g-0.100R	.791 (20.12)	1.500 (38.15)	1.375 (34.97)	1.811 (46.05)	.154 (3.92)	.242 (6.15)	.126 (3.20)

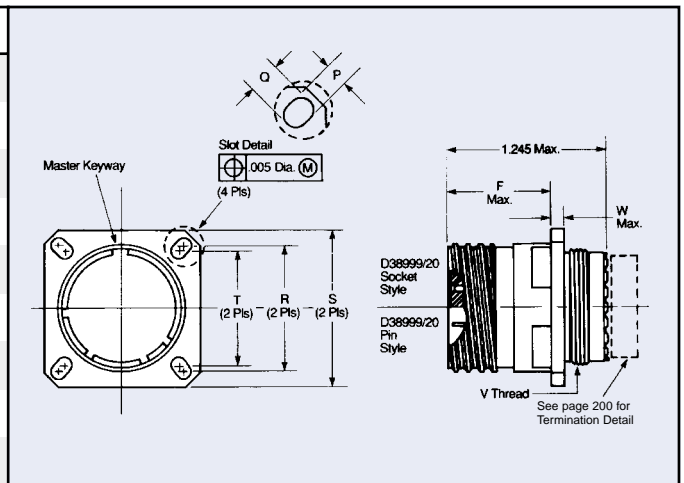

## D38999/24 Jam Nut

Shell Size	V Thread	F Dia.	S	Q	W
9	M12 X 1.0-6g-0.100R	1.189 (30.24)	1.063 (27.03)	.651 (16.55)	.087 (2.21)
11	M15 X 1.0-6g-0.100R	1.375 (34.97)	1.252 (31.84)	.751 (19.10)	.087 (2.21)
13	M18 X 1.0-6g-0.100R	1.500 (38.15)	1.374 (34.94)	.938 (23.85)	.087 (2.21)
15	M22 X 1.0-6g-0.100R	1.626 (41.35)	1.500 (38.15)	1.062 (27.01)	.087 (2.21)
17	M25 X 1.0-6g-0.100R	1.752 (44.55)	1.626 (41.35)	1.187 (30.19)	.087 (2.21)
19	M28 X 1.0-6g-0.100R	1.937 (49.26)	1.811 (46.05)	1.312 (33.36)	.118 (3.00)
21	M31 X 1.0-6g-0.100R	2.063 (52.46)	1.937 (49.26)	1.437 (36.54)	.118 (3.00)
23	M34 X 1.0-6g-0.100R	2.189 (55.67)	2.063 (52.46)	1.562 (39.72)	.118 (3.00)
25	M37 X 1.0-6g-0.100R	2.311 (58.77)	2.189 (55.67)	1.687 (42.90)	.118 (3.00)

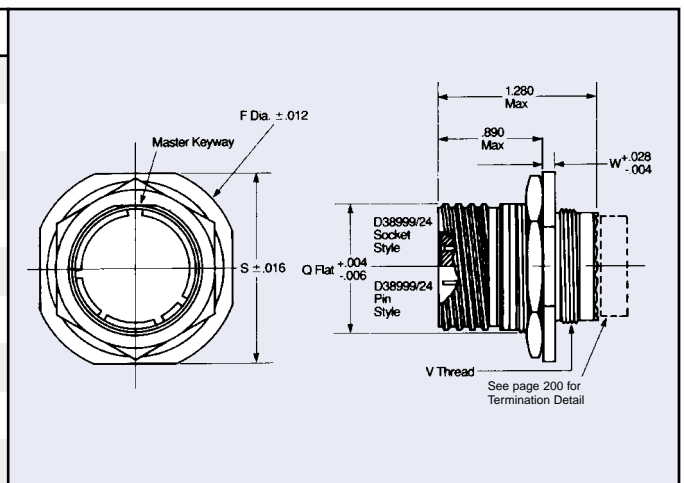

Dimensions in inches (mm)

## Extended Shell Filtered Connectors

This extended shell design is used in all MIL series connectors including 38999, 24308, 83723, and 26482. This connector is constructed by adding filters to the rear of a standard connector. The method of filtering can be either planars or tubular capacitors.

Extended shell connectors are ideal where quick turnaround is required for prototype devices. The range of filtering within the connector can be expanded due to the availability of either tubular or planar capacitors. In addition, custom schematics (such as double **Pi**, double **L**, or **T** sections) and transient voltage protection devices can be included in the connector.

For more information on extended shell connectors, refer to pages 207-223.



### Spectrum's Control Advantages

- **Retrofit existing connectors** - We can add filters to customer supplied connectors, saving time during prototype phase and expediting system evaluation.
- **Design flexibility and quality assurance** - We are vertically integrated with ceramic capacitors, enabling us to offer a broad selection of this critical component and ensuring design versatility and manufacturing control.
- **Prototypes** - Our EMI filtering expertise and large capacitor inventory allow us to quickly provide a working sample of your filtered connector.
- **Economy and turnaround** - Most components we utilize are standards, minimizing our tooling requirements and providing cost savings and a shorter lead time.
- **MIL and commercial applications** - Reduce program costs by utilizing our extended shell connectors for both MIL spec and commercial grade connectors.
- **Reduce testing and qualification** - Use of a QPL'd connector interface can expedite your approval process. In addition, we can filter any series of connectors . . . eliminating concerns over filter connector availability.

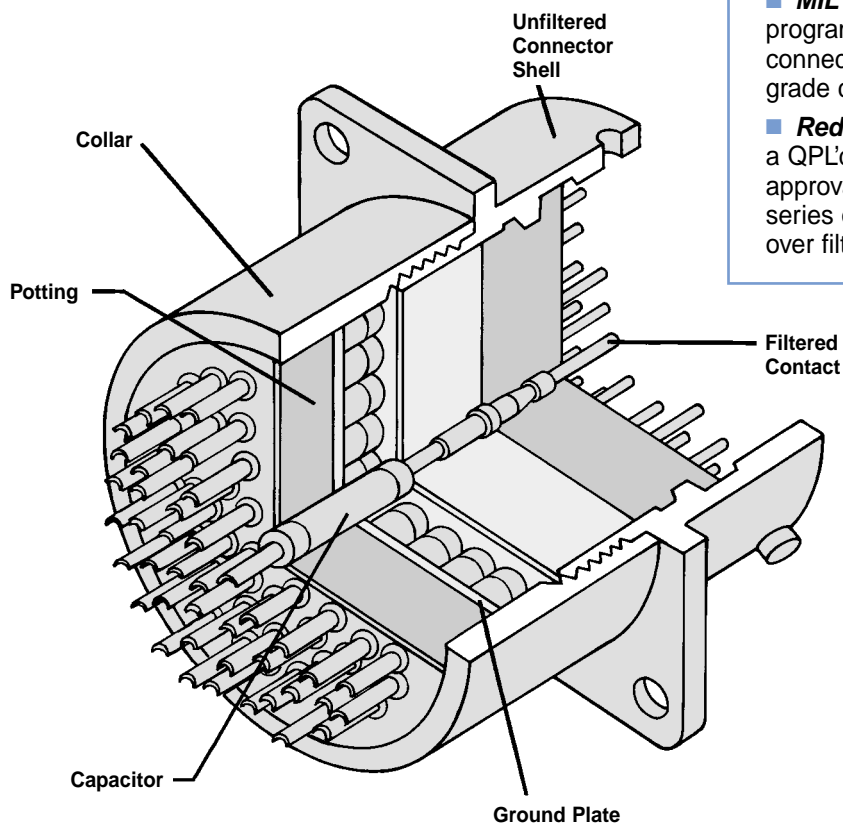

For 38999 compact shell design, see page 199.

# MIL-C-38999, Extended Shell



## Ordering Information

Available connector styles and shell sizes for this MIL series are shown on the following pages. Refer to these pages and the information below to develop your connector part number.

## Custom Designs

Due to the versatility provided with this product design, custom requirements can be readily accommodated. Consult Spectrum Control for your specific needs.

## Materials and Finishes

Shell . . . . . As noted in Ordering Information  
 Backshell. . . . . Copper Alloy, Nickel Plate  
 Contacts . . . . . Copper alloy, gold plate per MIL-G-45204

(For electrical specifications, see page 198.)

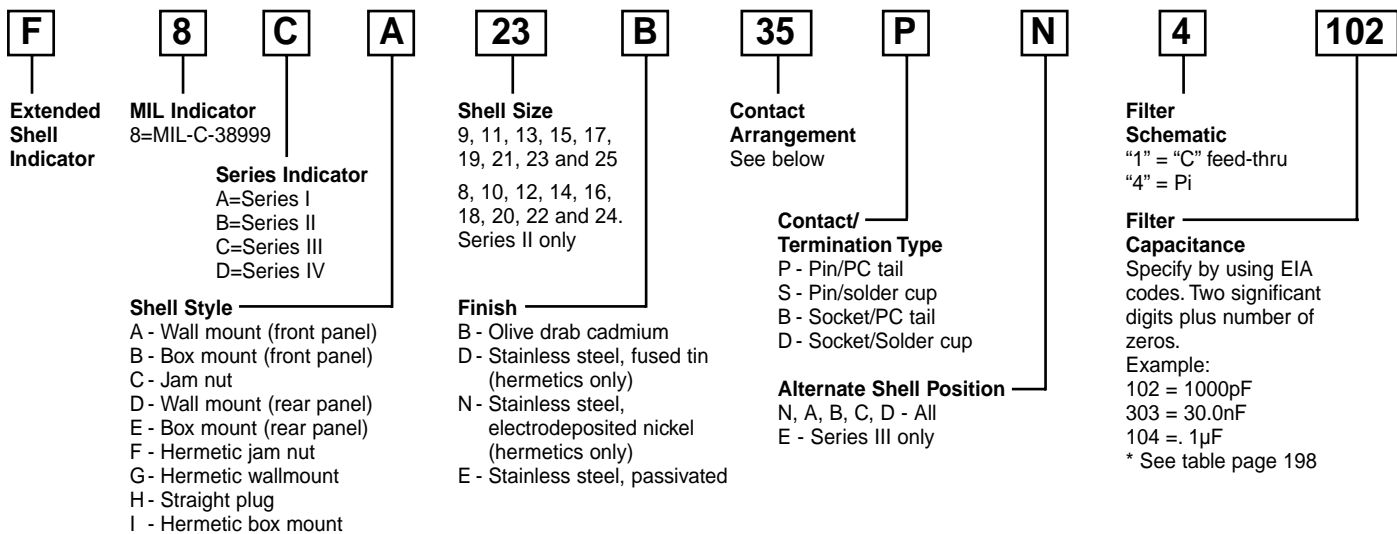

## Contact Arrangements (First two digits shell size, second two contact arrangement)

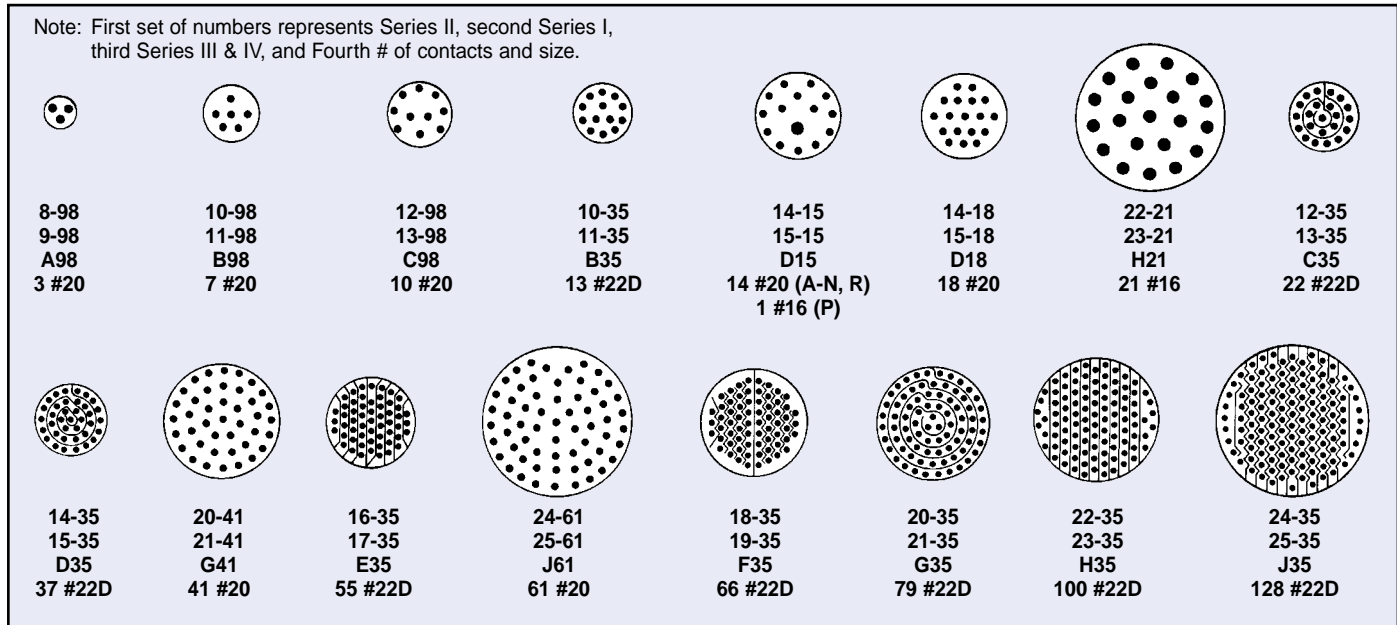

Note: For availability of filtered connectors with custom requirements, such as mixed capacitance, insulated lines, ground lines or other contact arrangements, consult factory for specific part number.

# MIL-C-38999, Extended Shell Series I

## MS27468 Jam Nut Receptacle

Shell Size	A	B	C	D	E	F	G	L
9	1.199 (30.45)	.697 (17.70)	.875 (22.23)	1.062 (26.97)	.669 (16.99)	.572 (14.53)	.515 (13.08)	1.715 (43.56)
11	1.386 (35.20)	.822 (20.88)	1.000 (25.40)	1.250 (31.75)	.769 (19.53)	.700 (17.78)	.640 (16.26)	1.715 (43.56)
13	1.511 (38.38)	1.007 (25.58)	1.188 (30.18)	1.375 (34.93)	.955 (24.26)	.850 (21.59)	.765 (19.43)	1.715 (43.56)
15	1.636 (41.55)	1.134 (28.80)	1.312 (33.32)	1.500 (38.10)	1.084 (27.53)	.975 (24.77)	.890 (22.61)	1.715 (43.56)
17	1.761 (44.73)	1.259 (31.98)	1.438 (36.53)	1.625 (41.28)	1.208 (30.68)	1.100 (27.94)	1.015 (25.78)	1.715 (43.56)
19	1.949 (49.50)	1.384 (35.15)	1.562 (39.67)	1.812 (46.02)	1.333 (33.86)	1.207 (30.66)	1.140 (28.96)	1.715 (43.56)
21	2.073 (52.65)	1.507 (38.28)	1.688 (42.88)	1.938 (49.23)	1.459 (37.06)	1.332 (33.83)	1.265 (32.13)	1.745 (44.32)
23	2.199 (55.85)	1.634 (41.50)	1.812 (46.02)	2.062 (52.37)	1.575 (40.01)	1.457 (37.01)	1.390 (35.31)	1.745 (44.32)
25	2.323 (59.00)	1.759 (44.68)	2.000 (50.80)	2.188 (55.58)	1.709 (43.41)	1.582 (40.18)	1.515 (38.48)	1.745 (44.32)

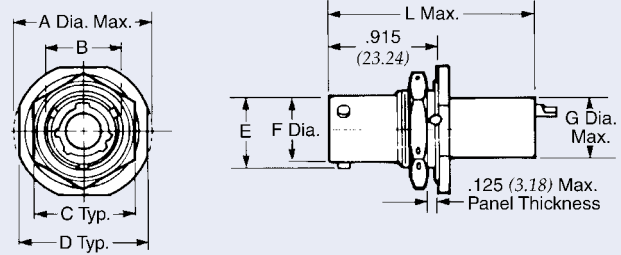

## MS27470 Hermetic Seal Jam Nut Receptacle

Shell Size	A	B	C	D	E	F	G	L
9	1.199 (30.45)	.697 (17.70)	.875 (22.23)	1.062 (26.97)	.669 (16.99)	.572 (14.53)	.730 (18.54)	1.860 (47.24)
11	1.386 (35.20)	.822 (20.88)	1.000 (25.40)	1.250 (31.75)	.769 (19.53)	.700 (17.78)	.855 (21.72)	1.860 (47.24)
13	1.511 (38.38)	1.007 (25.58)	1.188 (30.18)	1.375 (34.93)	.955 (24.26)	.850 (21.59)	.980 (24.89)	1.860 (47.24)
15	1.636 (41.55)	1.134 (28.80)	1.312 (33.32)	1.500 (38.10)	1.084 (27.53)	.975 (24.77)	1.105 (28.07)	1.860 (47.24)
17	1.761 (44.73)	1.259 (31.98)	1.438 (36.53)	1.625 (41.28)	1.208 (30.68)	1.100 (27.94)	1.230 (31.24)	1.860 (47.24)
19	1.949 (49.50)	1.384 (35.15)	1.562 (39.67)	1.812 (46.02)	1.333 (33.86)	1.207 (30.66)	1.355 (34.42)	1.885 (47.88)
21	2.073 (52.65)	1.507 (38.28)	1.688 (42.88)	1.938 (49.23)	1.459 (37.06)	1.332 (33.83)	1.405 (35.69)	1.885 (47.88)
23	2.199 (55.85)	1.634 (41.50)	1.812 (46.02)	2.062 (52.37)	1.575 (40.01)	1.457 (37.01)	1.605 (40.77)	1.885 (47.88)
25	2.323 (59.00)	1.759 (44.68)	2.000 (50.80)	2.188 (55.58)	1.709 (43.41)	1.582 (40.18)	1.730 (43.94)	1.885 (47.88)

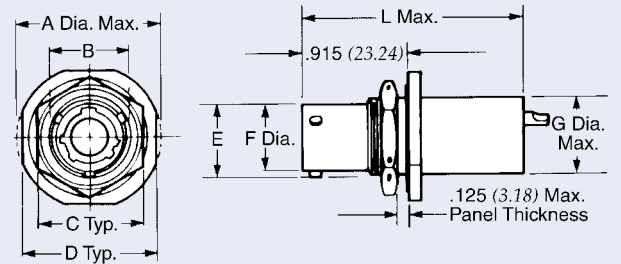

## MS27469 Hermetic Seal Wall Mount Receptacle

Shell Size	A	B	C	D	E
9	.938 (23.83)	.719 (18.26)	.128 (3.25)	.572 (14.53)	.765 (19.43)
11	1.031 (26.19)	.812 (20.62)	.128 (3.25)	.700 (17.78)	.890 (22.61)
13	1.125 (28.58)	.906 (23.01)	.128 (3.25)	.850 (21.59)	1.015 (25.78)
15	1.219 (30.96)	.969 (24.61)	.128 (3.25)	.975 (24.77)	1.140 (28.96)
17	1.312 (33.32)	1.062 (26.97)	.128 (3.25)	1.100 (27.94)	1.265 (28.96)
19	1.438 (36.53)	1.156 (29.36)	.128 (3.25)	1.207 (30.66)	1.390 (35.31)
21	1.562 (39.67)	1.250 (31.75)	.128 (3.25)	1.332 (33.83)	1.515 (38.48)
23	1.688 (42.88)	1.375 (34.93)	.147 (3.73)	1.457 (37.01)	1.640 (41.66)
25	1.812 (46.02)	1.500 (38.10)	.147 (3.73)	1.582 (40.18)	1.765 (44.83)

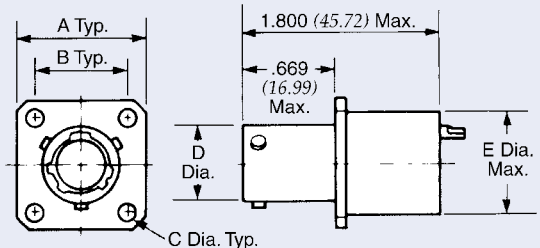

Dimensions in inches (mm)

# MIL-C-38999, Extended Shell Series I

## MS27496 Box Mount Receptacle, Front Panel Mounting

Shell Size	A	B	C	D	E
9	.938 (23.83)	.719 (18.26)	.572 (14.53)	.632 (16.05)	.495 (12.57)
11	1.031 (26.19)	.812 (20.62)	.700 (17.78)	.632 (16.05)	.620 (15.75)
13	1.125 (28.58)	.906 (23.01)	.850 (21.59)	.632 (16.05)	.745 (18.92)
15	1.219 (30.96)	.969 (24.61)	.975 (24.77)	.632 (16.05)	.870 (22.10)
17	1.312 (33.32)	1.062 (27.10)	1.100 (27.94)	.632 (16.05)	.995 (25.27)
19	1.438 (36.53)	1.156 (29.36)	1.207 (30.66)	.632 (16.05)	1.115 (28.32)
21	1.562 (39.67)	1.250 (31.75)	1.332 (33.83)	.602 (15.29)	1.235 (31.37)
23	1.688 (42.88)	1.375 (34.93)	1.457 (37.05)	.602 (15.29)	1.360 (34.54)
25	1.812 (46.02)	1.500 (38.10)	1.582 (40.18)	.602 (15.29)	1.485 (37.72)

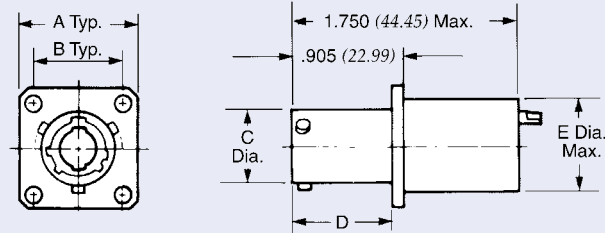

## MS27505 Box Mount Receptacle, Back Panel Mounting

Shell Size	A	B	C	D	E
9	.938 (23.83)	.719 (18.26)	.572 (14.53)	.820 (20.83)	.495 (12.57)
11	1.031 (26.19)	.812 (20.62)	.700 (17.78)	.820 (20.83)	.620 (15.75)
13	1.125 (28.58)	.906 (23.01)	.850 (21.59)	.820 (20.83)	.745 (18.92)
15	1.219 (30.96)	.969 (24.61)	.975 (24.77)	.820 (20.83)	.870 (22.10)
17	1.312 (33.32)	1.062 (27.10)	1.100 (27.94)	.820 (20.83)	.995 (25.27)
19	1.438 (36.53)	1.156 (29.36)	1.207 (30.66)	.820 (20.83)	1.115 (28.32)
21	1.562 (39.67)	1.250 (31.75)	1.332 (33.83)	.790 (20.07)	1.235 (31.37)
23	1.688 (42.88)	1.375 (34.93)	1.457 (37.01)	.790 (20.07)	1.360 (34.54)
25	1.812 (46.02)	1.500 (38.10)	1.582 (40.18)	.790 (20.07)	1.485 (37.72)

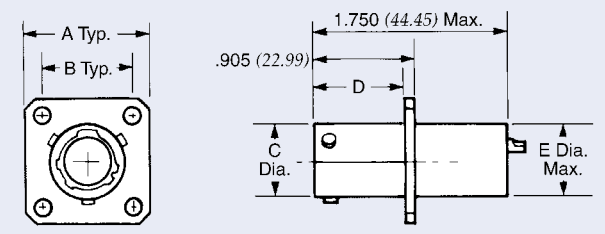

## MS27467 Straight Plug

Shell Size	A	B	V
9	.844 (21.44)	.540 (13.72)	.4375-28 UNEF-2A
11	.969 (24.61)	.660 (16.76)	.5625-24 UNEF-2A
13	1.141 (28.98)	.785 (19.94)	.6875-24 UNEF-2A
15	1.266 (32.16)	.915 (23.24)	.8125-20 UNEF-2A
17	1.391 (35.33)	1.025 (26.04)	.9375-20 UNEF-2A
19	1.500 (38.10)	1.145 (29.08)	1.0625-18 UNEF-2A
21	1.625 (41.28)	1.270 (32.26)	1.1875-18 UNEF-2A
23	1.750 (44.45)	1.395 (35.43)	1.3125-18 UNEF-2A
25	1.875 (47.63)	1.520 (38.61)	1.4375-18 UNEF-2A

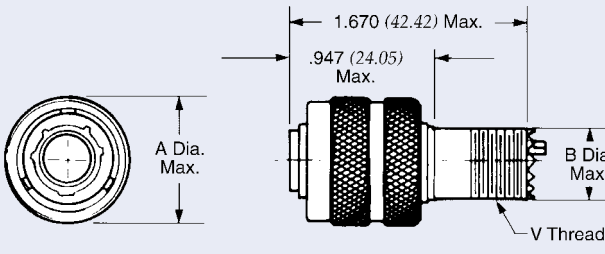

Dimensions in inches (mm)

# MIL-C-38999, Extended Shell Series II

## MS27477 Hermetic Jam Nut Receptacle

Shell Size	A	B	C	D	E	F	G	H
8	.830 (21.08)	1.390 (35.31)	1.250 (31.75)	1.062 (26.97)	.884 (22.45)	.438 (11.13)	.473 (12.01)	.435 (11.05)
10	.955 (24.26)	1.515 (38.48)	1.375 (34.93)	1.188 (30.18)	1.007 (25.58)	.438 (11.13)	.590 (14.99)	.525 (13.34)
12	1.084 (27.53)	1.640 (41.66)	1.500 (38.10)	1.312 (33.32)	1.134 (28.80)	.438 (11.13)	.750 (19.05)	.665 (16.89)
14	1.208 (30.68)	1.765 (44.83)	1.625 (41.28)	1.438 (36.53)	1.259 (31.98)	.438 (11.13)	.875 (22.23)	.785 (19.94)
16	1.333 (33.86)	1.953 (49.61)	1.781 (45.24)	1.562 (39.67)	1.384 (35.15)	.438 (11.13)	1.000 (25.40)	.915 (23.24)
18	1.459 (37.06)	2.031 (51.59)	1.890 (48.01)	1.688 (42.88)	1.507 (38.28)	.438 (11.13)	1.125 (28.50)	.985 (25.02)
20	1.576 (40.03)	2.156 (54.76)	2.016 (51.21)	1.812 (46.02)	1.634 (41.50)	.464 (11.79)	1.250 (31.75)	1.135 (28.83)
22	1.701 (43.21)	2.280 (57.91)	2.140 (54.31)	2.000 (50.80)	1.759 (44.68)	.464 (11.79)	1.375 (34.93)	1.255 (31.88)
24	1.826 (46.38)	2.405 (61.09)	2.265 (57.53)	2.125 (53.98)	1.884 (47.85)	.464 (11.79)	1.500 (38.10)	1.385 (35.18)

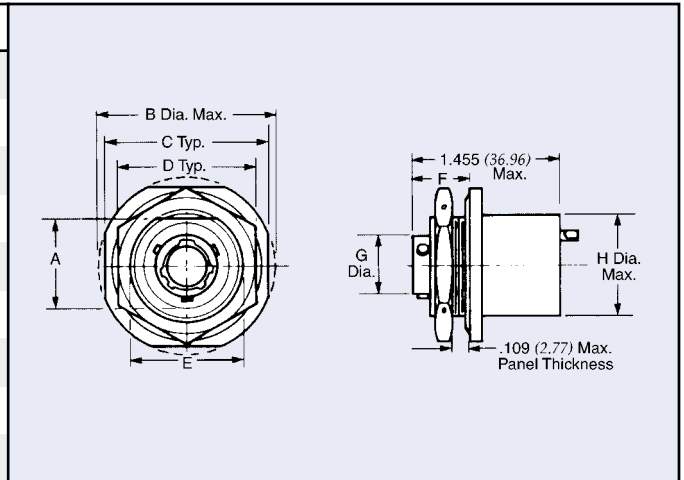

## MS27474 Jam Nut Receptacle

Shell Size	A	B	C	D	E	F	G	H	L
8	.830 (21.08)	1.390 (35.31)	1.250 (31.75)	1.062 (26.97)	.884 (22.45)	.438 (11.13)	.473 (12.01)	.515 (13.08)	1.370 (34.80)
10	.955 (24.26)	1.515 (38.48)	1.375 (34.93)	1.188 (30.18)	1.007 (25.58)	.438 (11.13)	.590 (14.99)	.640 (16.26)	1.370 (34.80)
12	1.084 (27.53)	1.640 (41.66)	1.500 (38.10)	1.312 (33.32)	1.134 (28.80)	.438 (11.13)	.750 (19.05)	.765 (19.43)	1.370 (34.80)
14	1.208 (30.68)	1.765 (44.83)	1.625 (41.28)	1.438 (36.53)	1.259 (31.98)	.438 (11.13)	.875 (22.23)	.890 (22.61)	1.370 (34.80)
16	1.333 (33.86)	1.953 (49.61)	1.781 (45.24)	1.562 (39.67)	1.384 (35.15)	.438 (11.13)	1.000 (25.40)	1.015 (25.78)	1.370 (34.80)
18	1.459 (37.06)	2.031 (51.59)	1.890 (48.01)	1.688 (42.88)	1.507 (38.28)	.438 (11.13)	1.125 (28.58)	1.140 (28.96)	1.370 (34.80)
20	1.576 (40.03)	2.156 (54.76)	2.016 (51.21)	1.812 (46.02)	1.634 (41.50)	.464 (11.79)	1.250 (31.75)	1.265 (32.13)	1.395 (35.43)
22	1.701 (43.21)	2.280 (57.91)	2.140 (54.36)	2.000 (50.80)	1.759 (44.68)	.464 (11.79)	1.375 (34.93)	1.390 (35.31)	1.395 (35.43)
24	1.826 (46.38)	2.405 (61.09)	2.265 (57.53)	2.125 (53.98)	1.884 (47.85)	.464 (11.79)	1.500 (38.10)	1.515 (38.48)	1.395 (35.43)

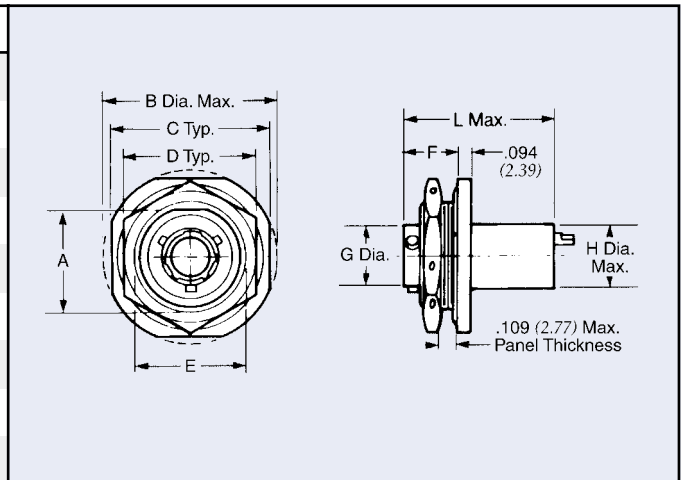

## MS27484 Straight Plug

Shell Size	A	B	V Thread Modified Class 2-A	Modified Major Dia.
8	.734 (18.64)	.540 (13.72)	.4375-28 UNEF	.421-.417
10	.844 (21.44)	.660 (16.76)	.5625-24 UNEF	.542-.538
12	1.016 (25.81)	.785 (19.94)	.6875-24 UNEF	.667-.663
14	1.141 (28.98)	.915 (23.24)	.8125-20 UNEF	.791-.787
16	1.265 (32.13)	1.025 (26.04)	.9375-20 UNEF	.916-.912
18	1.391 (35.33)	1.145 (29.08)	1.0625-18 UNEF	1.034-1.030
20	1.500 (38.10)	1.270 (32.26)	1.875-18 UNEF	1.158-1.154
22	1.625 (41.28)	1.395 (35.43)	1.3125-18 UNEF	1.283-1.279
24	1.750 (44.45)	1.520 (38.61)	1.4375-18 UNEF	1.408-1.404

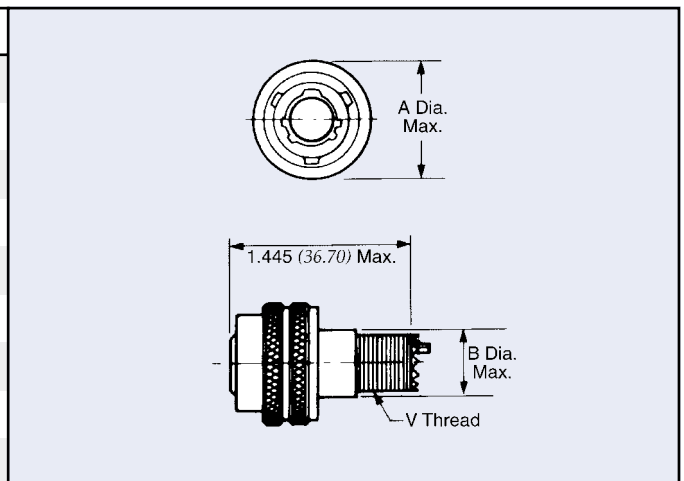

Dimensions in inches (mm)

# MIL-C-38999, Extended Shell Series II

## MS27508 Box Mount Receptacle, Back Panel Mounting

Shell Size	A	B	C	D
8	.812 (20.62)	.594 (15.09)	.473 (12.01)	.495 (12.57)
10	.938 (23.83)	.719 (18.26)	.590 (14.99)	.620 (15.75)
12	1.031 (26.19)	.812 (20.62)	.750 (19.05)	.745 (18.92)
14	1.125 (28.58)	.906 (23.01)	.875 (22.23)	.870 (22.10)
16	1.219 (30.96)	.969 (24.61)	1.000 (25.40)	.995 (25.27)
18	1.312 (33.32)	1.062 (27.10)	1.125 (28.58)	1.115 (28.32)
20	1.438 (36.53)	1.156 (29.36)	1.250 (31.75)	1.235 (31.37)
22	1.562 (39.67)	1.250 (31.75)	1.375 (34.93)	1.360 (34.54)
24	1.688 (42.88)	1.375 (34.93)	1.500 (38.10)	1.485 (37.72)

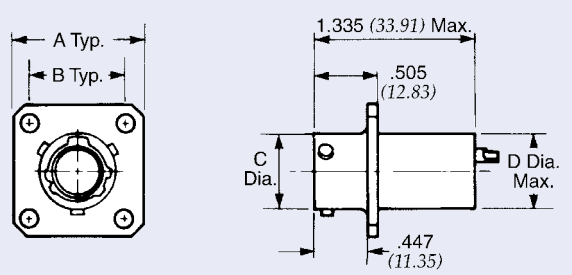

## MS27476 Hermetic Seal, Box Mount Receptacle

Shell Size	A	B	C	D
10	.938 (23.83)	.719 (18.26)	.590 (14.99)	.750 (19.05)
12	1.031 (26.19)	.812 (20.62)	.750 (19.05)	.860 (21.84)
14	1.125 (28.58)	.906 (23.01)	.875 (22.23)	.985 (25.02)
16	1.219 (30.96)	.969 (24.61)	1.000 (25.40)	1.110 (28.19)
18	1.312 (33.32)	1.062 (26.97)	1.125 (28.58)	1.235 (31.37)
20	1.438 (36.53)	1.156 (29.36)	1.250 (31.75)	1.330 (33.78)
22	1.562 (39.67)	1.250 (31.75)	1.375 (34.93)	1.455 (36.96)
24	1.688 (42.88)	1.375 (34.93)	1.500 (38.10)	1.580 (40.13)

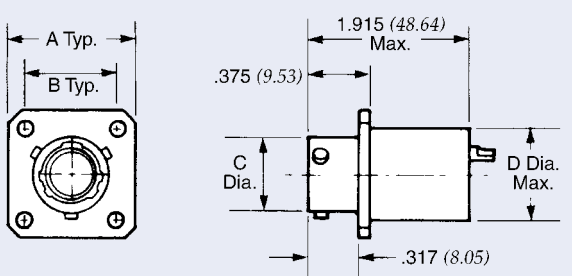

## MS27499 Box Mount Receptacle, Front Panel Mounting

Shell Size	A	B	C	D
8	.812 (20.62)	.594 (15.09)	.473 (12.01)	.495 (12.57)
10	.938 (23.83)	.719 (18.26)	.590 (14.99)	.620 (15.75)
12	1.031 (26.19)	.812 (20.62)	.750 (19.05)	.745 (18.92)
14	1.125 (28.58)	.906 (23.01)	.875 (22.23)	.870 (22.10)
16	1.219 (30.96)	.969 (24.61)	1.000 (25.40)	.995 (25.27)
18	1.312 (33.32)	1.062 (26.97)	1.125 (28.58)	1.115 (28.32)
20	1.438 (36.53)	1.156 (29.36)	1.250 (31.75)	1.235 (31.37)
22	1.562 (39.67)	1.250 (31.75)	1.375 (34.93)	1.360 (34.54)
24	1.688 (42.88)	1.375 (34.93)	1.500 (38.10)	1.485 (37.72)

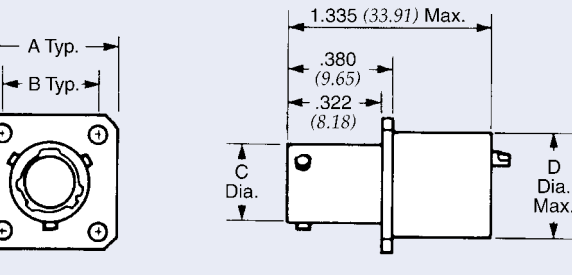

Dimensions in inches (mm)

# MIL-C-38999, Extended Shell Series III



## D38999/20 Wall Mount Receptacle

Shell Size	MS Shell Size Code	A	B	BB	C	CC	D	E
9	A	.938 (23.83)	.719 (18.26)	.594 (15.09)	.128 (3.25)	.216 (5.49)	.820 (20.83)	.550 (13.97)
11	B	1.031 (26.19)	.812 (20.62)	.719 (18.26)	.128 (3.25)	.194 (4.93)	.820 (20.83)	.670 (17.02)
13	C	1.125 (28.58)	.906 (23.01)	.812 (20.62)	.128 (3.25)	.194 (4.93)	.820 (20.83)	.785 (19.94)
15	D	1.219 (30.96)	.969 (24.61)	.906 (23.01)	.128 (3.25)	.173 (4.39)	.820 (20.83)	.945 (24.00)
17	E	1.312 (33.32)	1.062 (26.97)	.969 (24.61)	.128 (3.25)	.194 (4.93)	.820 (20.83)	1.060 (26.92)
19	F	1.438 (36.53)	1.156 (29.36)	1.062 (26.97)	.128 (3.25)	.194 (4.93)	.820 (20.83)	1.180 (29.97)
21	G	1.562 (39.67)	1.250 (31.75)	1.156 (29.36)	.128 (3.25)	.194 (4.93)	.790 (20.07)	1.295 (32.89)
23	H	1.688 (42.88)	1.375 (34.93)	1.250 (31.75)	.154 (3.91)	.242 (6.15)	.790 (20.07)	1.415 (35.94)
25	J	1.812 (46.02)	1.500 (38.10)	1.375 (34.93)	.154 (3.91)	.242 (6.15)	.790 (20.07)	1.535 (38.99)

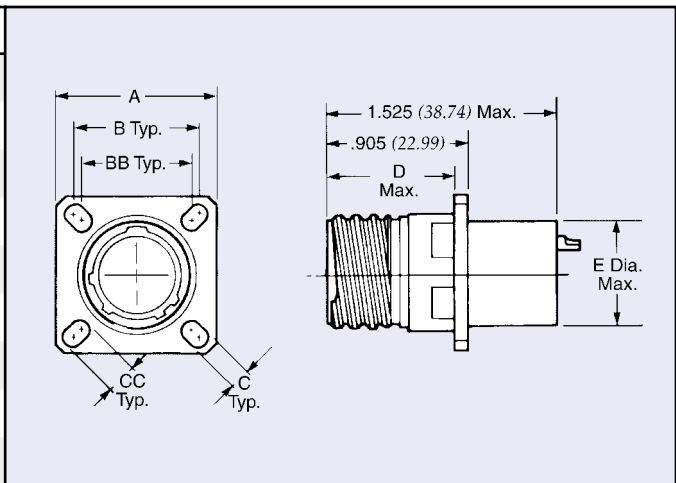

## D38999/21 Hermetic Seal Box Mount Receptacle

Shell Size	MS Shell Size Code	A	B	BB	C	CC	D	E
9	A	.937 (23.80)	.719 (18.26)	.594 (15.09)	.128 (3.25)	.216 (5.49)	.843 (21.41)	.380 (9.65)
11	B	1.031 (26.20)	.812 (20.62)	.719 (18.26)	.128 (3.25)	.194 (4.93)	.843 (21.41)	.500 (12.70)
13	C	1.126 (28.60)	.906 (23.01)	.812 (20.62)	.128 (3.25)	.194 (4.93)	.843 (21.41)	.620 (15.75)
15	D	1.220 (31.00)	.969 (24.61)	.906 (23.01)	.128 (3.25)	.194 (4.93)	.843 (21.41)	.775 (19.68)
17	E	1.311 (33.30)	1.062 (26.97)	.969 (24.61)	.128 (3.25)	.194 (4.93)	.843 (21.41)	.895 (22.73)
19	F	1.437 (36.50)	1.156 (29.36)	1.062 (26.97)	.128 (3.25)	.194 (4.93)	.843 (21.41)	1.010 (25.65)
21	G	1.563 (39.70)	1.250 (31.75)	1.156 (29.36)	.128 (3.25)	.194 (4.93)	.843 (21.41)	1.130 (28.70)
23	H	1.689 (42.90)	1.375 (34.93)	1.250 (31.75)	.154 (3.91)	.242 (6.15)	.843 (21.41)	1.250 (31.75)
25	J	1.811 (46.00)	1.500 (38.10)	1.375 (34.93)	.154 (3.91)	.242 (6.15)	.843 (21.41)	1.365 (34.67)

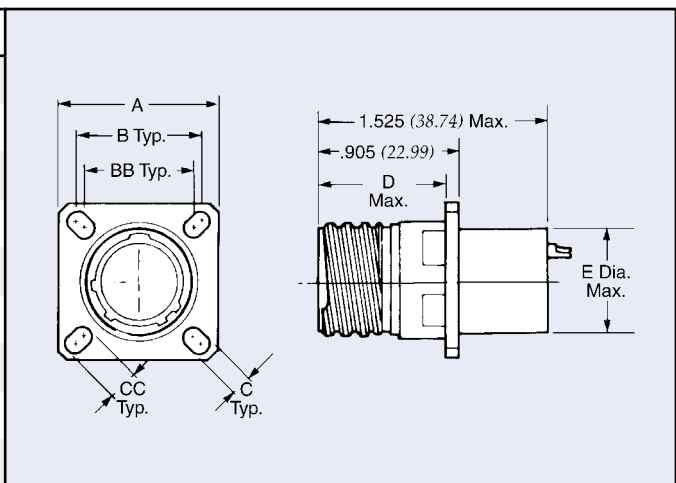

Dimensions in inches (mm)

# MIL-C-38999, Extended Shell Series III

## D38999/24 Jam Nut Receptacle

Shell Size	MS Shell Size Code	A	B	C	D	E	F	G	L
9	A	1.199 (30.45)	.697 (17.70)	.875 (22.23)	1.062 (26.97)	.871 (22.12)	.669 (16.99)	.550 (13.97)	1.595 (40.51)
11	B	1.386 (35.20)	.822 (20.88)	1.000 (25.40)	1.250 (31.75)	.871 (22.12)	.769 (19.53)	.670 (17.02)	1.595 (40.51)
13	C	1.511 (38.38)	1.007 (25.58)	1.188 (30.18)	1.375 (34.93)	.878 (22.30)	.955 (24.26)	.785 (19.94)	1.595 (40.51)
15	D	1.636 (41.55)	1.134 (28.80)	1.312 (33.32)	1.500 (38.10)	.878 (22.30)	1.084 (27.53)	.945 (24.00)	1.595 (40.51)
17	E	1.761 (44.73)	1.259 (31.98)	1.438 (36.53)	1.625 (41.28)	.878 (22.30)	1.208 (30.68)	1.060 (26.92)	1.595 (40.51)
19	F	1.949 (49.50)	1.384 (35.15)	1.562 (39.67)	1.812 (46.02)	.878 (22.30)	1.333 (33.86)	1.180 (29.97)	1.630 (41.40)
21	G	2.073 (52.65)	1.507 (38.28)	1.688 (42.88)	1.938 (49.23)	.878 (22.30)	1.459 (37.06)	1.295 (32.89)	1.630 (41.40)
23	H	2.199 (55.85)	1.634 (41.50)	1.812 (46.02)	2.062 (52.37)	.878 (22.30)	1.575 (40.01)	1.415 (35.94)	1.630 (41.40)
25	J	2.323 (59.00)	1.759 (44.68)	2.000 (50.80)	2.188 (55.58)	.878 (22.30)	1.709 (43.41)	1.535 (38.99)	1.630 (41.40)

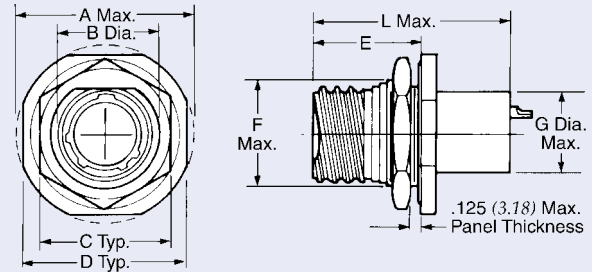

## D38999/23 Hermetic Seal Jam Nut Receptacle

Shell Size	MS Shell Size Code	A	B	C	D	E	F	G	L
9	A	1.199 (30.45)	.697 (17.70)	.875 (22.23)	1.062 (26.97)	.871 (22.12)	.669 (16.99)	.730 (18.54)	1.955 (49.66)
11	B	1.386 (35.20)	.822 (20.88)	1.000 (25.40)	1.250 (31.75)	.871 (22.12)	.769 (19.53)	.845 (21.46)	1.955 (49.66)
13	C	1.511 (38.38)	1.007 (25.58)	1.188 (30.18)	1.375 (34.93)	.878 (22.30)	.955 (24.26)	.970 (24.64)	1.955 (49.66)
15	D	1.636 (41.55)	1.134 (28.80)	1.312 (33.32)	1.500 (38.10)	.878 (22.30)	1.084 (27.53)	1.095 (27.81)	1.955 (49.66)
17	E	1.761 (44.73)	1.259 (31.98)	1.438 (36.53)	1.625 (41.28)	.878 (22.30)	1.208 (30.68)	1.220 (30.99)	1.955 (49.66)
19	F	1.949 (49.50)	1.384 (35.15)	1.562 (39.67)	1.812 (46.02)	.878 (22.30)	1.333 (33.86)	1.345 (34.16)	1.985 (50.42)
21	G	2.073 (52.65)	1.507 (38.28)	1.688 (42.88)	1.938 (49.23)	.878 (22.30)	1.459 (37.06)	1.470 (37.34)	1.985 (50.42)
23	H	2.199 (55.85)	1.634 (41.50)	1.812 (46.02)	2.062 (52.37)	.878 (22.30)	1.575 (40.01)	1.595 (40.51)	1.985 (50.42)
25	J	2.323 (59.00)	1.759 (44.68)	2.000 (50.80)	2.188 (55.58)	.878 (22.30)	1.709 (43.41)	1.720 (43.69)	1.985 (50.42)

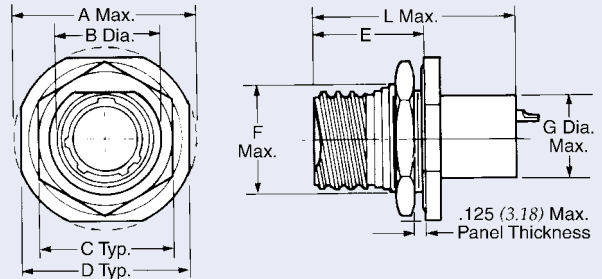

## D38999/26 Straight Plug

Shell Size	MS Shell Size Code	A	B	V Thread
9	A	.859 (21.82)	.580 (14.73)	M12 X1.0-6g-0.1R
11	B	.969 (24.61)	.695 (17.65)	M15X1.0-6g-0.1R
13	C	1.141 (28.98)	.810 (20.57)	M18X1.0-6g-0.1R
15	D	1.266 (32.16)	.965 (24.51)	M22X1.0-6g-0.1R
17	E	1.391 (35.33)	1.080 (27.43)	M25X1.0-6g-0.1R
19	F	1.500 (38.10)	1.195 (30.35)	M28X1.0-6g-0.1R
21	G	1.625 (41.28)	1.310 (33.27)	M31X1.0-6g-0.1R
23	H	1.750 (44.45)	1.425 (36.20)	M34X1.0-6g-0.1R
25	J	1.875 (47.63)	1.540 (39.12)	M37X1.0-6g-0.1R

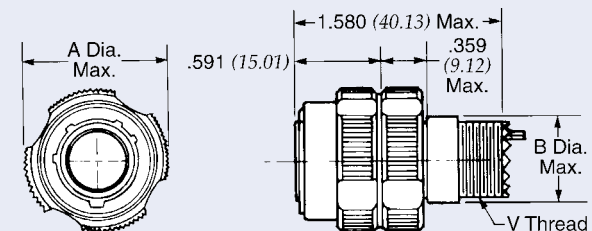

Dimensions in inches (mm)

# MIL-C-38999, Extended Shell Series IV



## D38999/40 Wall Mount Receptacle

Shell Size	MS Size Size Code	A	B	C	D	E	F	L
11	B	1.051 (26.70)	.406 (10.31)	.509 (12.93)	.793 (20.14)	.102 (2.59)	.670 (17.02)	1.785 (45.34)
13	C	1.145 (29.08)	.453 (11.51)	.634 (16.10)	.919 (23.34)	.102 (2.59)	.785 (19.94)	1.785 (45.34)
15	D	1.240 (31.50)	.4845 (12.31)	.759 (19.28)	1.044 (26.52)	.102 (2.59)	.945 (24.00)	1.785 (45.34)
17	E	1.334 (33.88)	.531 (13.49)	.885 (22.48)	1.170 (29.72)	.102 (2.59)	1.060 (26.92)	1.785 (45.34)
19	F	1.480 (37.06)	.578 (14.68)	1.009 (25.63)	1.294 (32.87)	.102 (2.59)	1.180 (29.97)	1.785 (45.34)
21	G	1.582 (40.18)	.625 (15.88)	1.134 (28.80)	1.419 (36.04)	.133 (3.38)	1.295 (32.89)	1.815 (46.10)
23	H	1.708 (43.38)	.6875 (17.46)	1.259 (31.98)	1.544 (39.22)	.133 (3.38)	1.415 (35.94)	1.815 (46.10)
25	J	1.834 (46.58)	.750 (19.05)	1.384 (35.15)	1.669 (42.39)	.133 (3.38)	1.535 (38.99)	1.815 (46.10)

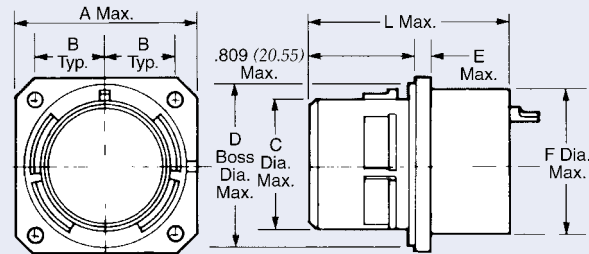

## D38999/41 Hermetic Seal Box Mount Receptacle

Shell Size	MS Size Size Code	A	B	C	D	E	L
11	B	1.051 (26.70)	.406 (10.31)	.093 (2.36)	.509 (12.93)	.500 (12.70)	1.785 (45.34)
13	C	1.145 (29.08)	.453 (11.51)	.093 (2.36)	.634 (16.10)	.620 (15.75)	1.785 (45.34)
15	D	1.240 (31.50)	.4845 (12.31)	.093 (2.36)	.759 (19.28)	.775 (19.68)	1.785 (45.34)
17	E	1.334 (33.88)	.531 (13.49)	.093 (2.36)	.885 (22.48)	.895 (22.73)	1.785 (45.34)
19	F	1.480 (37.06)	.578 (14.68)	.093 (2.36)	1.009 (25.68)	1.010 (25.65)	1.785 (45.34)
21	G	1.582 (40.18)	.625 (15.88)	.093 (2.36)	1.134 (28.80)	1.130 (28.70)	1.815 (46.10)
23	H	1.708 (43.38)	.6875 (17.46)	.093 (2.36)	1.259 (31.90)	1.250 (31.75)	1.815 (46.10)
25	J	1.834 (46.58)	.750 (19.05)	.093 (2.36)	1.384 (35.15)	1.365 (34.67)	1.815 (46.10)

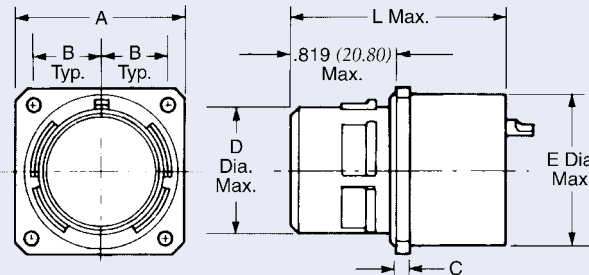

Dimensions in inches (mm)

# MIL-C-38999, Extended Shell Series IV

## D38999/42 Box Mount Receptacle

Shell Size	Shell Size Code	A	B	C	D	E	L
11	B	1.051 (26.70)	.406 (10.31)	.102 (2.59)	.509 (12.93)	.655 (16.64)	1.785 (45.34)
13	C	1.145 (29.08)	.453 (11.51)	.102 (2.59)	.634 (16.10)	.770 (19.56)	1.785 (45.34)
15	D	1.240 (31.50)	.4845 (12.31)	.102 (2.59)	.759 (19.28)	.895 (22.73)	1.785 (45.34)
17	E	1.334 (33.88)	.531 (13.49)	.102 (2.59)	.885 (22.48)	1.020 (25.91)	1.785 (45.34)
19	F	1.460 (37.08)	.578 (14.68)	.102 (2.59)	1.009 (25.63)	1.130 (28.70)	1.785 (45.34)
21	G	1.582 (40.18)	.626 (15.90)	.133 (3.38)	1.134 (28.80)	1.250 (31.75)	1.815 (46.10)
23	H	1.708 (43.38)	.6875 (17.46)	.133 (3.38)	1.259 (31.98)	1.375 (34.93)	1.815 (46.10)
25	J	1.834 (46.58)	.750 (19.05)	.133 (3.38)	1.384 (35.15)	1.500 (38.10)	1.815 (46.10)

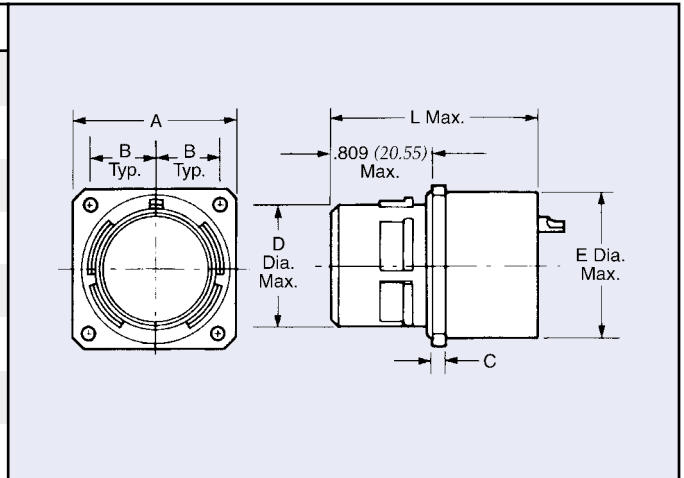

## D38999/44 Jam Nut Receptacle

Shell Size	MS Shell Size Code	A	B	C	D
11	B	1.394 (35.41)	1.260 (32.00)	.509 (12.93)	.670 (17.02)
13	C	1.520 (38.61)	1.417 (36.00)	.634 (16.10)	.785 (19.94)
15	D	1.642 (41.71)	1.614 (41.00)	.759 (19.28)	.945 (24.00)
17	E	1.799 (45.69)	1.614 (41.00)	.885 (22.48)	1.060 (26.92)
19	F	1.909 (48.49)	1.811 (46.00)	1.009 (25.63)	1.180 (29.97)
21	G	2.035 (51.69)	1.968 (50.00)	1.134 (28.80)	1.295 (32.89)
23	H	2.157 (54.79)	1.968 (50.00)	1.259 (31.98)	1.415 (35.94)
25	J	2.283 (57.99)	2.165 (55.00)	1.384 (35.15)	1.535 (38.99)

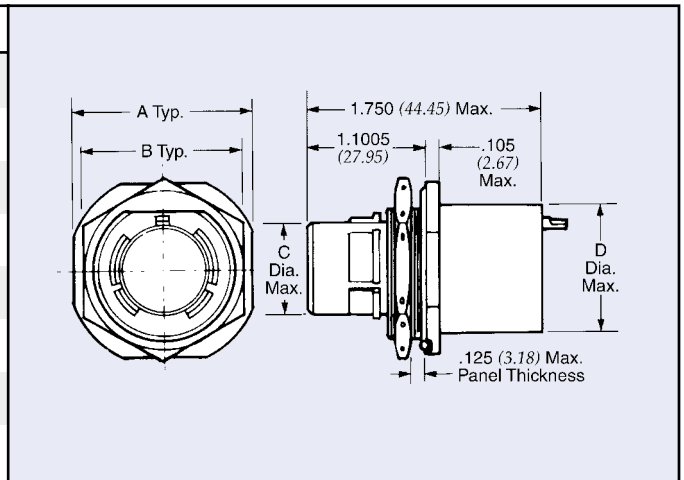

## D38999/46 Straight Plug

Shell Size	MS Shell Size Code	A	B	C	V
11	B	1.054 (26.77)	.775 (19.69)	.695 (17.65)	M15x1.0-6g-0.1R
13	C	1.226 (31.14)	.901 (22.89)	.810 (20.57)	M18x1.0-6g-0.1R
15	D	1.351 (34.32)	1.039 (26.39)	.965 (24.51)	M22x1.0-6g-0.1R
17	E	1.476 (37.49)	1.149 (29.18)	1.080 (27.43)	M25x1.0-6g-0.1R
19	F	1.586 (40.28)	1.275 (32.39)	1.195 (30.35)	M28x1.0-6g-0.1R
21	G	1.711 (43.46)	1.401 (35.59)	1.310 (33.27)	M31x1.0-6g-0.1R
23	H	1.836 (46.63)	1.527 (38.79)	1.425 (36.20)	M34x1.0-6g-0.1R
25	J	1.964 (49.89)	1.649 (41.88)	1.540 (39.12)	M37x1.0-6g-0.1R

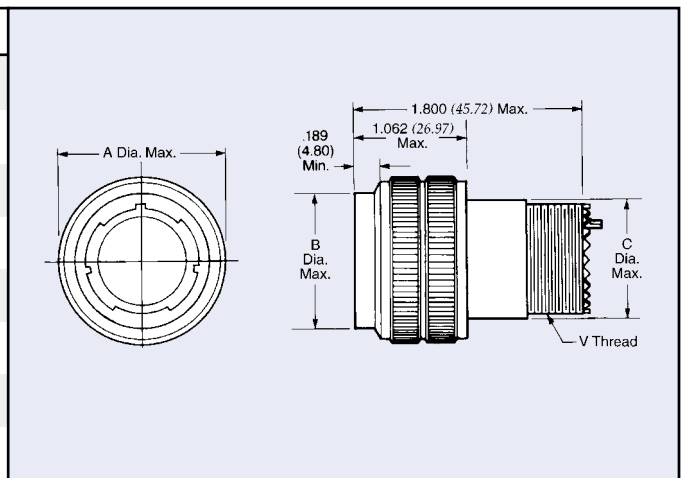

Dimensions in inches (mm)

# MIL-C-83723, Extended Shell Series III

All extended shell connectors are manufactured by adding filters to a standard MIL qualified connector. The filtering is achieved by extending the connector with the use of a backshell and placing either planar or tubular capacitors in the backshell. Spectrum will always keep the extension to a minimum.

These miniature circular filtered connectors are designed to meet the applicable portions of MIL-C-83723 and are interchangeable with that specification.

## Custom Designs

Due to the versatility provided with this product design, custom requirements can be readily accommodated. Consult Spectrum Control for your specific needs.

## Materials and Finishes

Shell . . . . . As noted in Ordering Information  
 Backshell . . . . . Copper Alloy, Nickel Plate  
 Contacts . . . . . Copper alloy, gold plate per MIL-G-45204

(For electrical specifications, see page 198.)

## Ordering Information

Available connector styles and shell sizes for this MIL series are shown on the following pages. Refer to these pages and the information below to develop your connector part number.

Filtered Connectors

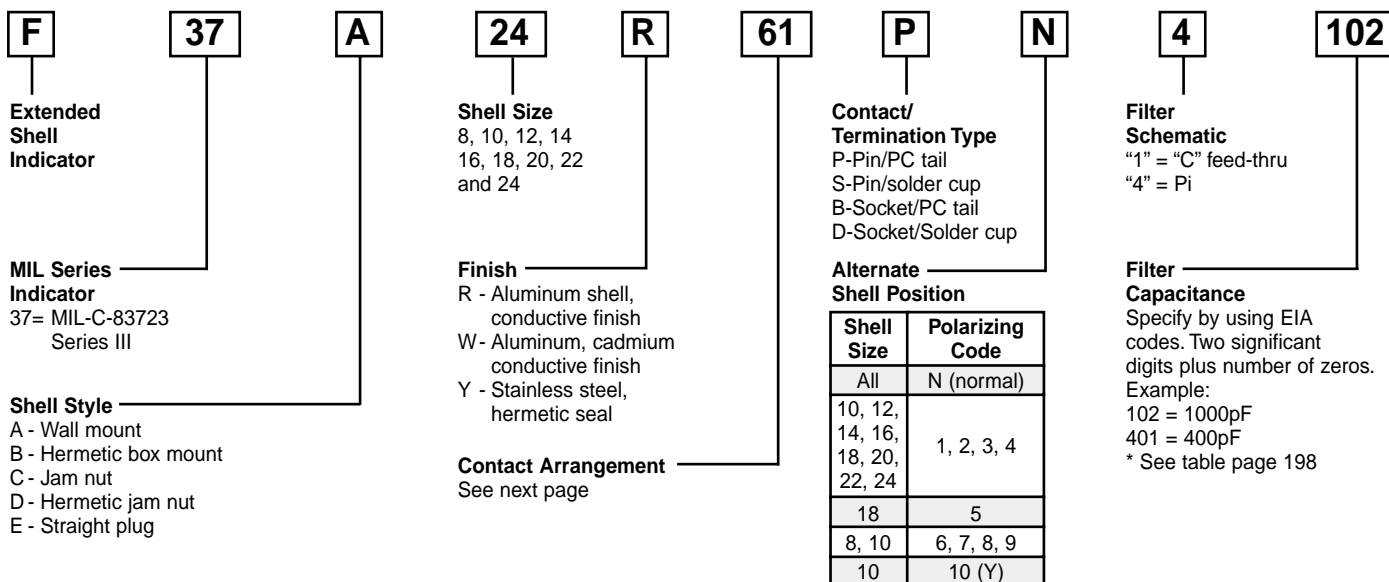

## Spectrum's Control Advantages

- **Retrofit existing connectors** - We can add filters to customer supplied connectors, saving time during prototype phase and expediting system evaluation.
- **Design flexibility and quality assurance** - We are vertically integrated with ceramic capacitors, enabling us to offer a broad selection of this critical component and ensuring design versatility and manufacturing control.
- **Prototypes** - Our EMI filtering expertise and large capacitor inventory allow us to quickly provide a working sample of your filtered connector.
- **Economy and turnaround** - Most components we utilize are standards, minimizing our tooling requirements and providing cost savings and a shorter lead time.
- **MIL and commercial applications** - Reduce program costs by utilizing our extended shell connectors for both MIL spec and commercial grade connectors.
- **Reduce testing and qualification** - Use of a QPL'd connector interface can expedite your approval process. In addition, we can filter any series of connectors . . . eliminating concerns over filter connector availability.

# MIL-C-83723, Extended Shell Series III

## Contact Arrangements (First two digits shell size, second two contact arrangement)



8-2  
2 #20



10-2  
2 #20



10-20  
2 #16



8-3  
3 #20



8-98  
3 #20



12-3  
3 #16



12-4  
4 #16



10-5  
5 #20



10-6  
6 #20

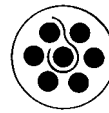

14-7  
7 #16

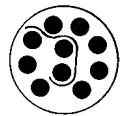

10-16  
10 #16

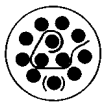

12-12  
12 #20

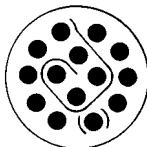

18-14  
14 #16

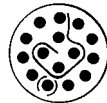

14-15  
15 #20

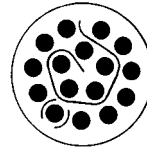

20-16  
16 #16

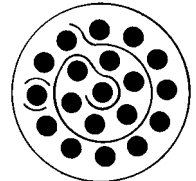

22-19  
19 #16

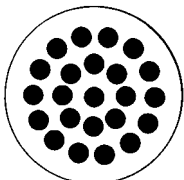

22-23  
23 #16

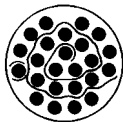

16-24  
24 #20

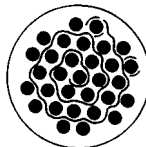

18-31  
31 #20

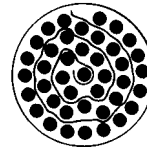

20-41  
41 #20

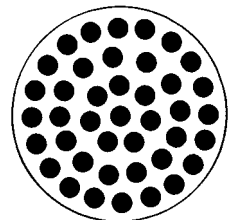

28-41  
41 #16

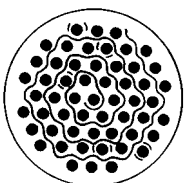

22-55  
55 #20

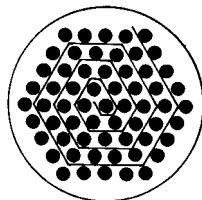

24-61  
61 #20

**Note:**  
For availability of filtered connectors with custom requirements, such as mixed capacitance, insulated lines, ground lines or other contact arrangements, consult factory for specific part number.

Filtered Connectors

# MIL-C-83723, Extended Shell Series III



## M83723/71/72 Bayonet Coupling Wall Mount Receptacle

Shell Size	A	B	C	D	E
8	.812 (20.62)	.594 (15.09)	.120 (3.05)	.562 (14.27)	.575 (14.61)
10	.937 (23.80)	.719 (18.26)	.120 (3.05)	.696 (17.68)	.700 (17.78)
12	1.031 (26.19)	.812 (20.62)	.120 (3.05)	.875 (22.23)	.825 (20.96)
14	1.125 (28.58)	.906 (23.01)	.120 (3.05)	.935 (23.75)	.950 (24.13)
16	1.250 (31.75)	.969 (24.61)	.120 (3.05)	1.062 (26.97)	1.075 (27.31)
18	1.343 (34.11)	1.062 (26.97)	.120 (3.05)	1.187 (30.15)	1.140 (28.96)
20	1.473 (37.41)	1.156 (29.36)	.120 (3.05)	1.312 (33.32)	1.265 (32.13)
22	1.562 (39.67)	1.250 (31.75)	.120 (3.05)	1.437 (36.50)	1.340 (34.04)
24	1.703 (43.26)	1.375 (34.93)	.149 (3.78)	1.562 (39.67)	1.515 (38.48)

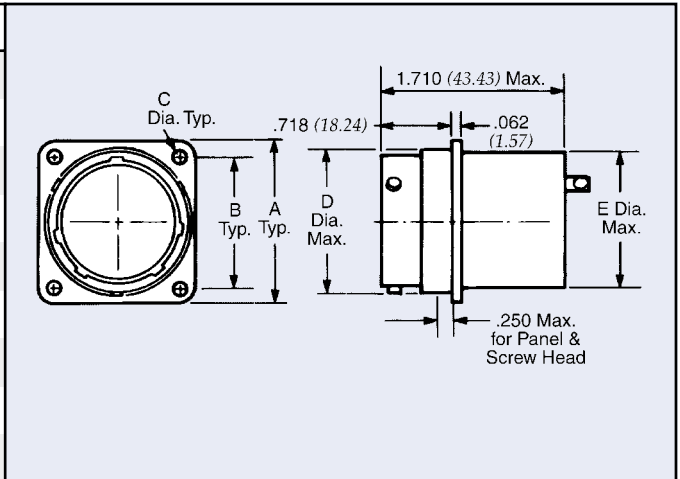

## M83723/79 Bayonet Coupling Hermetic Box Receptacle

Shell Size	A	B	C	D	E
8	.812 (20.62)	.594 (15.09)	.120 (3.05)	.562 (14.27)	.580 (14.73)
10	.937 (23.80)	.719 (18.26)	.120 (3.05)	.696 (17.68)	.645 (16.38)
12	1.031 (26.19)	.812 (20.62)	.120 (3.05)	.875 (22.23)	.830 (21.08)
14	1.125 (28.58)	.906 (23.01)	.120 (3.05)	.935 (23.75)	.895 (22.73)
16	1.250 (31.75)	.969 (24.61)	.120 (3.05)	1.062 (26.97)	1.020 (25.91)
18	1.343 (34.11)	1.062 (26.97)	.120 (3.05)	1.187 (30.15)	1.145 (29.08)
20	1.473 (37.41)	1.156 (29.36)	.120 (3.05)	1.312 (33.32)	1.270 (32.26)
22	1.562 (39.67)	1.250 (31.75)	.120 (3.05)	1.437 (36.50)	1.395 (35.43)
24	1.703 (43.26)	1.375 (34.93)	.149 (3.78)	1.562 (39.67)	1.520 (38.61)

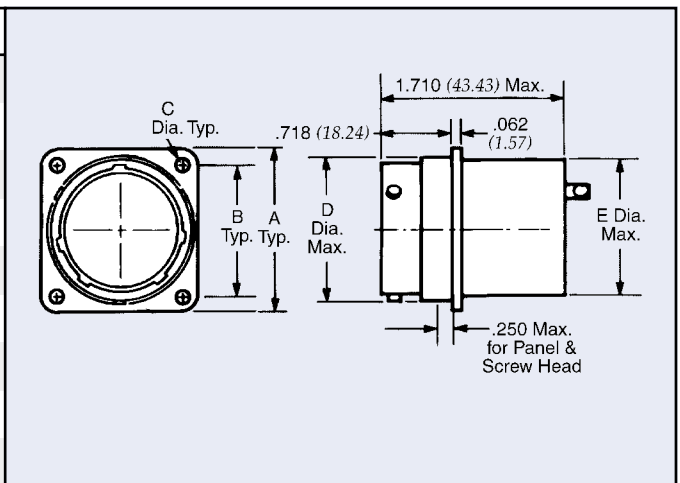

Dimensions in inches (mm)

# MIL-C-83723, Extended Shell Series III

## M83723/73/74 Bayonet Coupling Jam Nut Receptacle

Shell Size	A	B	C	L
8	.979 (24.87)	1.068 (27.13)	.575 (14.61)	1.830 (46.48)
10	1.104 (28.04)	1.192 (30.28)	.700 (17.78)	1.830 (46.48)
12	1.291 (32.79)	1.380 (35.05)	.825 (20.96)	1.830 (46.48)
14	1.391 (35.33)	1.505 (38.23)	.950 (24.13)	1.830 (46.48)
16	1.516 (38.51)	1.630 (41.40)	1.075 (27.31)	1.830 (46.48)
18	1.641 (41.68)	1.756 (44.60)	1.140 (28.96)	1.830 (46.48)
20	1.766 (44.86)	1.860 (47.24)	1.265 (32.13)	1.830 (46.48)
22	1.954 (49.63)	2.068 (52.53)	1.340 (34.04)	1.860 (47.24)
24	2.079 (52.81)	2.160 (54.86)	1.515 (38.48)	1.860 (47.24)

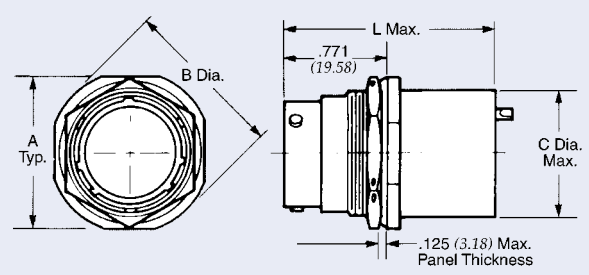

## M83723/81 Bayonet Coupling Hermetic Jam Nut Receptacle

Shell Size	A	B	C	L
8	.979 (24.87)	1.068 (27.13)	.490 (12.45)	1.670 (42.42)
10	1.104 (28.04)	1.192 (30.28)	.550 (13.97)	1.670 (42.42)
12	1.291 (32.79)	1.380 (35.05)	.740 (18.80)	1.670 (42.42)
14	1.391 (35.33)	1.505 (38.23)	.800 (20.32)	1.670 (42.42)
16	1.516 (38.51)	1.630 (41.40)	.925 (23.50)	1.670 (42.42)
18	1.641 (41.68)	1.756 (44.24)	1.050 (26.67)	1.670 (42.42)
20	1.766 (44.86)	1.860 (47.24)	1.240 (31.50)	1.670 (42.42)
22	1.954 (49.63)	2.068 (52.53)	1.300 (33.02)	1.670 (42.42)
24	2.079 (52.81)	2.160 (54.86)	1.490 (37.85)	1.670 (42.42)

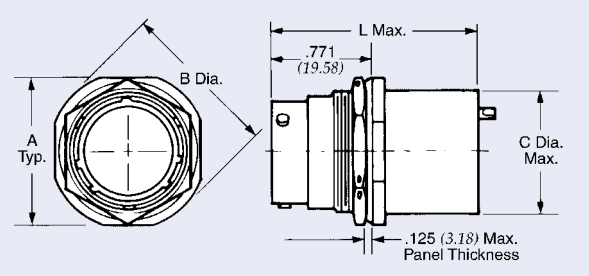

## M83723/77/78 Bayonet Coupling Straight Plug

Shell Size	A	B	V
8	.766 (19.46)	.590 (14.99)	1/2-20 UNEF-2A
10	.906 (23.01)	.720 (18.29)	5/8-24 UNEF-2A
12	1.078 (27.38)	.840 (21.34)	3/4-20 UNEF-2A
14	1.141 (28.98)	.965 (24.51)	7/8-20 UNEF-2A
16	1.266 (32.16)	1.090 (27.69)	1-20 UNEF-2A
18	1.375 (34.93)	1.14 (29.08)	1 1/16-18 UNEF-2A
20	1.510 (38.35)	1.270 (32.26)	1 3/16-18 UNEF-2A
22	1.625 (41.28)	1.395 (35.43)	1 5/16-18 UNEF-2A
24	1.760 (44.70)	1.520 (38.61)	1 7/16-18 UNEF-2A

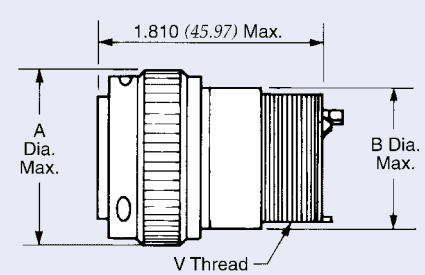

Dimensions in inches (mm)

# MIL-C-26482, Extended Shell



All extended shell connectors are manufactured by adding filters to a standard MIL qualified connector. The filtering is achieved by extending the connector with the use of a backshell and placing either planar or tubular capacitors in the backshell. Spectrum will always keep the extension to a minimum.

These miniature circular filtered connectors are designed to meet the applicable portions of MIL-C-83723 and are interchangeable with that specification.

## Custom Designs

Due to the versatility provided with this product design, custom requirements can be readily accommodated. Consult Spectrum Control for your specific needs.

## Materials and Finishes

Shell . . . . . As noted in Ordering Information  
 Backshell . . . . . Copper Alloy, Nickel Plate  
 Contacts . . . . . Copper alloy, gold plate per MIL-G-45204

(For electrical specifications, see page 198.)

## Ordering Information

Available connector styles and shell sizes for this MIL series are shown on the following pages. Refer to these pages and the information below to develop your connector part number.

## Spectrum's Control Advantages

- **Retrofit existing connectors** - We can add filters to customer supplied connectors, saving time during prototype phase and expediting system evaluation.
- **Design flexibility and quality assurance** - We are vertically integrated with ceramic capacitors, enabling us to offer a broad selection of this critical component and ensuring design versatility and manufacturing control.
- **Prototypes** - Our EMI filtering expertise and large capacitor inventory allow us to quickly provide a working sample of your filtered connector.
- **Economy and turnaround** - Most components we utilize are standards, minimizing our tooling requirements and providing cost savings and a shorter lead time.
- **MIL and commercial applications** - Reduce program costs by utilizing our extended shell connectors for both MIL spec and commercial grade connectors.
- **Reduce testing and qualification** - Use of a QPL'd connector interface can expedite your approval process. In addition, we can filter any series of connectors . . . eliminating concerns over filter connector availability.

Filtered Connectors

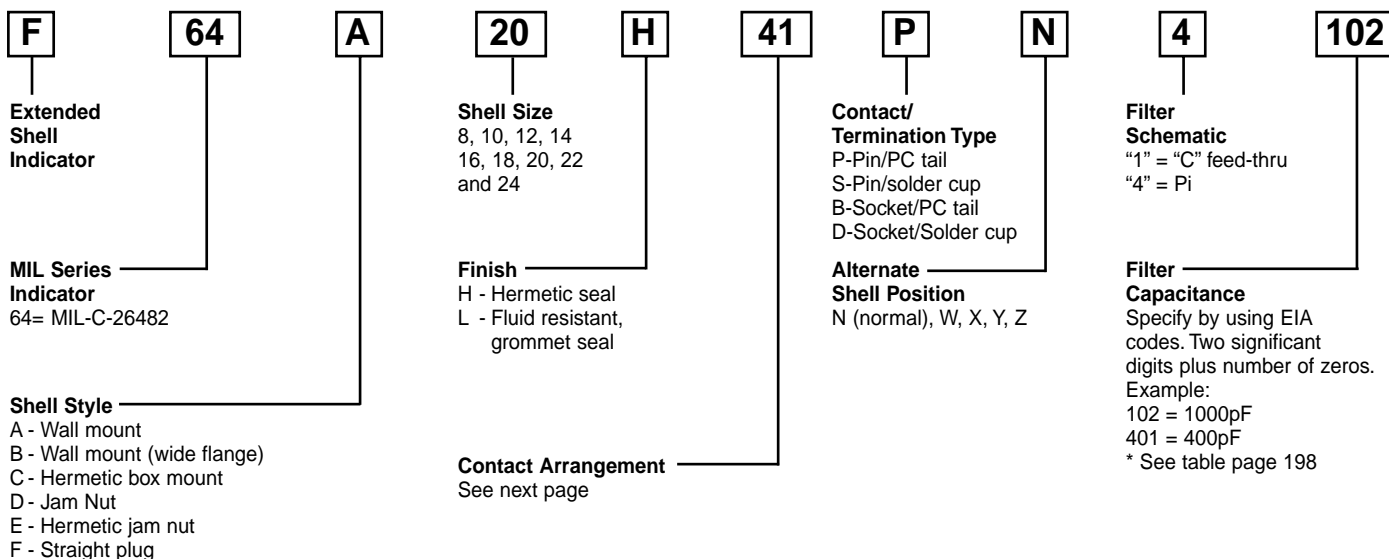

# MIL-C-26482, Extended Shell

## Contact Arrangements (First two digits shell size, second two contact arrangement)



8-98  
3 #20

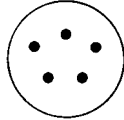

14-5  
5 #16

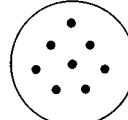

16-8  
8 #16

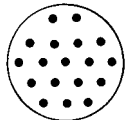

14-18  
18 #20

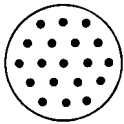

14-19  
19 #20

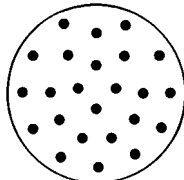

20-24  
24 #20

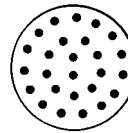

16-26  
26 #20

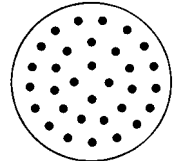

18-32  
18 #20

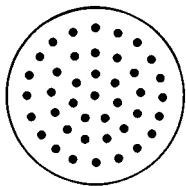

20-41  
41 #20

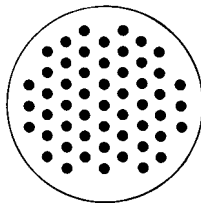

22-53  
53 #20

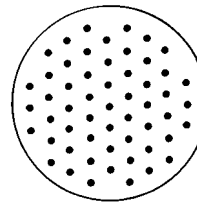

22-55  
55 #20

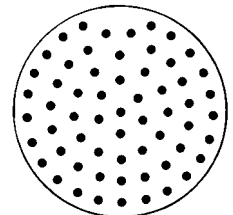

24-61  
61 #20

**Note:**

For availability of filtered connectors with custom requirements, such as mixed capacitance, insulated lines, ground lines or other contact arrangements, consult factory for specific part number.

# MIL-C-26482, Extended Shell

## MS3470 Wall Mount Receptacle

Shell Size	A	B	C	D	E	F	L
8	.828 (21.03)	.594 (15.09)	.446 (11.33)	.062 (1.57)	.087 (2.21)	.575 (14.61)	1.575 (40.01)
10	.954 (24.23)	.719 (18.26)	.446 (11.33)	.062 (1.57)	.087 (2.21)	.700 (17.78)	1.575 (40.01)
12	1.047 (26.59)	.812 (20.62)	.446 (11.33)	.062 (1.57)	.087 (2.21)	.825 (20.96)	1.575 (40.01)
14	1.141 (28.98)	.906 (23.01)	.446 (11.33)	.062 (1.57)	.087 (2.21)	.950 (24.13)	1.575 (40.01)
16	1.234 (31.34)	.969 (24.61)	.446 (11.33)	.062 (1.57)	.087 (2.21)	1.075 (27.31)	1.575 (40.01)
18	1.328 (33.73)	1.062 (26.97)	.446 (11.33)	.062 (1.57)	.087 (2.21)	1.140 (28.96)	1.575 (40.01)
20	1.453 (36.91)	1.156 (29.36)	.572 (14.53)	.094 (2.39)	.212 (5.38)	1.265 (32.13)	1.735 (44.07)
22	1.578 (40.08)	1.250 (31.75)	.572 (14.53)	.094 (2.39)	.212 (5.38)	1.340 (34.04)	1.735 (44.07)
24	1.703 (43.26)	1.375 (34.93)	.604 (15.34)	.094 (2.39)	.212 (5.38)	1.515 (38.48)	1.765 (44.83)

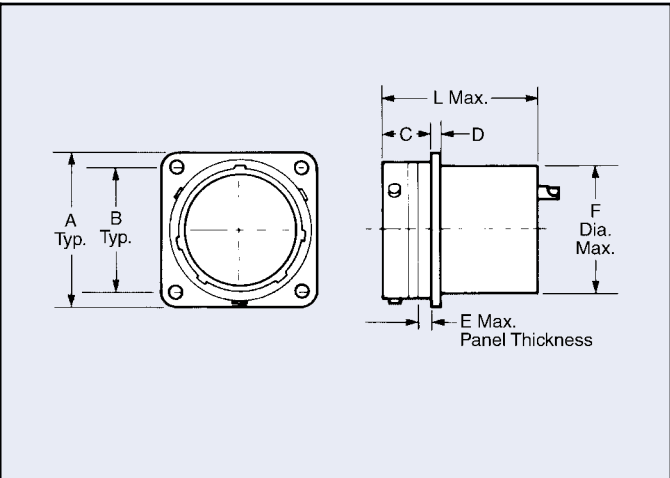

## MS3472 Wide Flange Wall Mount Receptacle

Shell Size	A	B	C	D	E	F	L
8	1.065 (27.05)	.734 (18.64)	.477 (12.12)	.062 (1.57)	.118 (3.00)	.575 (14.61)	1.605 (40.77)
10	1.141 (28.98)	.812 (20.62)	.477 (12.12)	.062 (1.57)	.118 (3.00)	.700 (17.78)	1.605 (40.77)
12	1.266 (32.16)	.938 (23.83)	.477 (12.12)	.062 (1.57)	.118 (3.00)	.825 (20.96)	1.605 (40.77)
14	1.360 (34.54)	1.031 (26.19)	.477 (12.12)	.062 (1.57)	.118 (3.00)	.950 (24.13)	1.605 (40.77)
16	1.453 (36.91)	1.125 (28.58)	.477 (12.12)	.062 (1.57)	.118 (3.00)	1.075 (27.31)	1.605 (40.77)
18	1.532 (38.91)	1.203 (30.56)	.477 (12.12)	.062 (1.57)	.118 (3.00)	1.140 (28.96)	1.605 (40.77)
20	1.688 (42.88)	1.297 (32.94)	.571 (14.50)	.094 (2.39)	.212 (5.38)	1.265 (32.13)	1.735 (44.07)
22	1.766 (44.86)	1.375 (34.93)	.571 (14.50)	.094 (2.39)	.212 (5.38)	1.340 (34.04)	1.735 (44.07)
24	1.891 (48.03)	1.500 (38.10)	.604 (15.34)	.094 (2.39)	.212 (5.38)	1.515 (38.48)	1.765 (44.83)

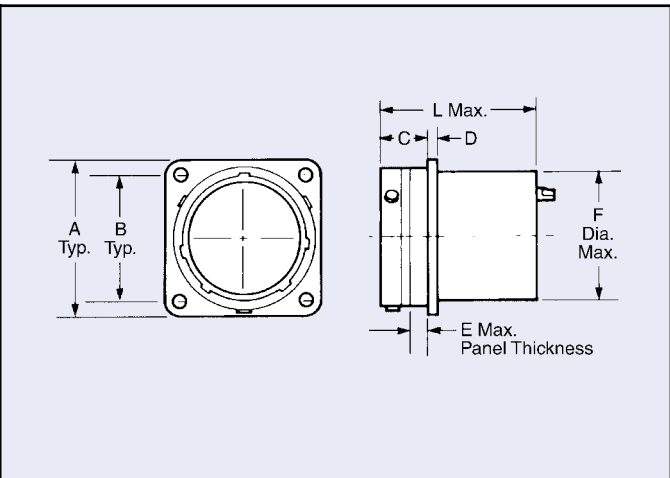

## MS3440 Hermetic Seal Box Mount Receptacle

Shell Size	A	B	C	D	E	F	L
10	.954 (24.23)	.719 (18.26)	.588 (14.94)	.062 (1.57)	.087 (2.21)	.750 (19.05)	1.750 (44.45)
12	1.047 (26.59)	.812 (20.62)	.588 (14.94)	.062 (1.57)	.087 (2.21)	.860 (21.84)	1.750 (44.45)
14	1.141 (28.98)	.906 (23.01)	.588 (14.94)	.062 (1.57)	.087 (2.21)	.990 (25.15)	1.750 (44.45)
16	1.234 (31.34)	.969 (24.61)	.588 (14.94)	.062 (1.57)	.087 (2.21)	1.110 (28.19)	1.750 (44.45)
18	1.328 (33.73)	1.062 (26.97)	.588 (14.94)	.062 (1.57)	.087 (2.21)	1.235 (31.37)	1.750 (44.45)
20	1.453 (36.91)	1.156 (29.36)	.650 (16.51)	.094 (2.39)	.212 (5.38)	1.330 (33.78)	1.850 (46.99)
22	1.578 (40.08)	1.250 (31.75)	.650 (16.51)	.094 (2.39)	.212 (5.38)	1.455 (36.96)	1.850 (46.99)
24	1.703 (43.26)	1.375 (34.93)	.650 (16.51)	.094 (2.39)	.212 (5.38)	1.580 (40.13)	1.750 (44.45)

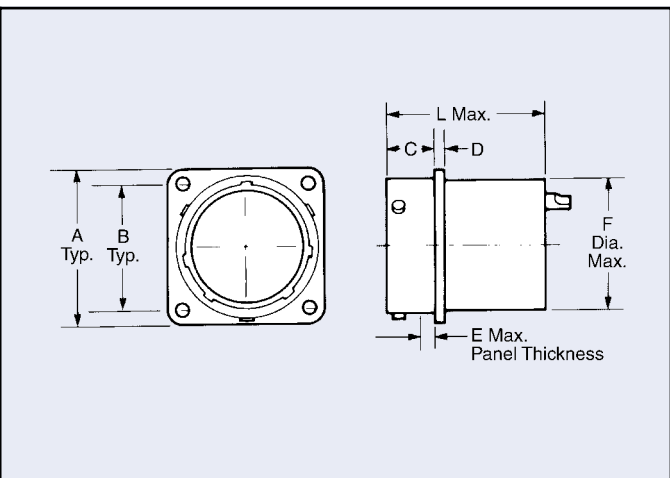

Dimensions in inches (mm)

# MIL-C-26482, Extended Shell

## MS3474 Jam Nut Receptacle

Shell Size	A	B	C	D	E	L
8	.938 (23.83)	1.063 (27.00)	.575 (14.61)	.187 (4.75)	.683 (17.35)	1.870 (47.50)
10	1.063 (27.00)	1.187 (30.15)	.700 (17.78)	.187 (4.75)	.683 (17.35)	1.870 (47.50)
12	1.250 (31.75)	1.346 (34.19)	.825 (20.96)	.187 (4.75)	.683 (17.35)	1.870 (47.50)
14	1.346 (34.19)	1.500 (38.10)	.950 (24.13)	.187 (4.75)	.683 (17.35)	1.870 (47.50)
16	1.500 (38.10)	1.625 (41.28)	1.075 (27.31)	.187 (4.75)	.683 (17.35)	1.870 (47.50)
18	1.625 (41.28)	1.750 (44.45)	1.140 (28.96)	.187 (4.75)	.683 (17.35)	1.870 (47.50)
20	1.812 (46.02)	1.938 (49.23)	1.265 (32.13)	.250 (6.35)	.746 (18.95)	1.970 (50.04)
22	1.938 (49.23)	2.063 (52.40)	1.340 (34.04)	.250 (6.35)	.746 (18.95)	1.970 (50.04)
24	2.063 (52.40)	2.187 (55.55)	1.515 (38.48)	.219 (5.56)	.746 (18.95)	1.970 (50.04)

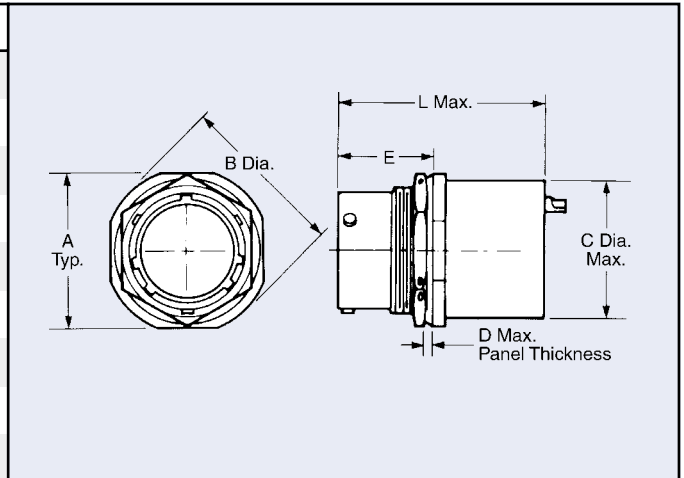

## MS3449 Hermetic Seal Jam Nut Receptacle

Shell Size	A	B	C	D	L
8	.938 (23.83)	1.063 (27.00)	.410 (10.41)	.699 (17.75)	1.750 (44.45)
10	1.063 (27.00)	1.187 (30.15)	.520 (13.21)	.699 (17.75)	1.750 (44.45)
12	1.250 (31.75)	1.346 (34.19)	.630 (16.00)	.699 (17.75)	1.750 (44.45)
14	1.346 (34.19)	1.500 (38.10)	.760 (19.30)	.699 (17.75)	1.750 (44.45)
16	1.500 (38.10)	1.625 (41.28)	.880 (22.35)	.699 (17.75)	1.750 (44.45)
18	1.625 (41.28)	1.750 (44.45)	.980 (24.89)	.699 (17.75)	1.750 (44.45)
20	1.812 (46.02)	1.938 (49.23)	1.110 (28.19)	.762 (19.35)	1.850 (46.99)
22	1.938 (49.23)	2.063 (52.40)	1.230 (31.24)	.762 (19.35)	1.850 (46.99)
24	2.063 (52.40)	2.187 (55.55)	1.390 (35.31)	.762 (19.35)	1.880 (47.75)

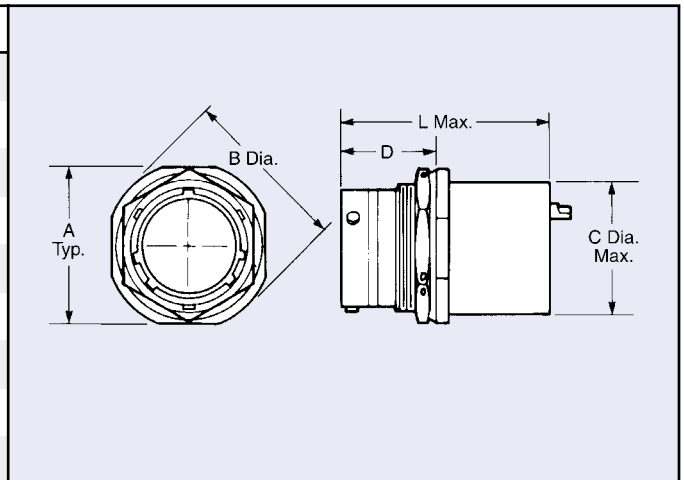

## MS3475 Straight Plug

Shell Size	A	B	V Thread
8	.782 (19.86)	.590 (14.99)	1/2-20 UNEF-2A
10	.926 (23.52)	.720 (18.29)	5/8-24 UNEF-2A
12	1.043 (26.49)	.840 (21.34)	3/4-20 UNEF-2A
14	1.183 (30.05)	.965 (24.51)	7/8-20 UNEF-2A
16	1.305 (33.15)	1.090 (27.69)	1-20 UNEF-2A
18	1.391 (35.33)	1.145 (29.08)	1 1/16-18 UNEF-2A
20	1.531 (38.89)	1.270 (32.26)	1 3/16-18 UNEF-2A
22	1.656 (42.06)	1.395 (35.43)	1 5/16-18 UNEF-2A
24	1.777 (45.14)	1.520 (38.61)	1 7/16-18 UNEF-2A

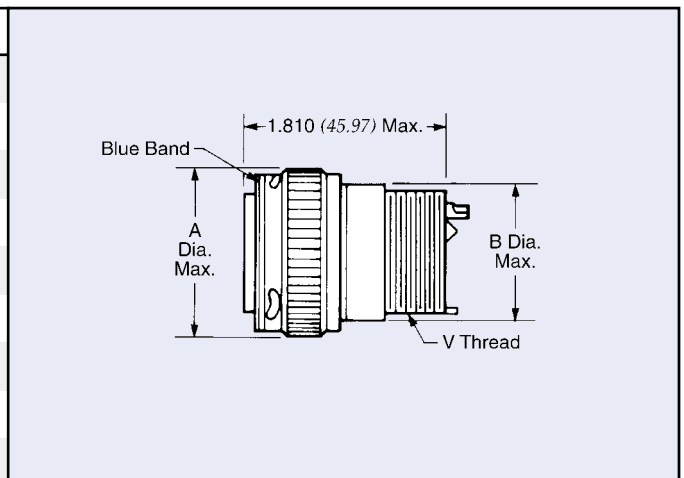

Dimensions in inches (mm)

# Custom Filtered Connectors

## Wire Harnesses

Spectrum Control will add wires to the filtered connector to allow the customer to easily install the connector into the system at a lower cost. These value-added services include adding wires terminated or unterminated to all lines or only select lines, twisted pairs and labeling of wires for easy placement in your system. We can also encapsulate the wires inside the connector providing strength to the total harness.

By contracting Spectrum Control to add the harness assembly, customers are assured the performance of the filtered connector has not been adversely affected. **All of our custom connectors are 100% tested for integrity and effective performance.**

Spectrum's connector manufacturing operators are all certified to MIL-STD-2000 solder specification. We have invested in this certification to provide you with confidence that the quality of our custom construction meets the highest standards in the industry.

Wire Harnesses



## Sole Sourced Military Connectors

Many systems being designed today have made use of connectors that are sole sourced items. Examples of these include MIL-C-81511, MIL-C-81703, Airborn and Lemo connectors. We will design and manufacture a custom filtered connector that specifically addresses the requirements of unique applications such as oil and gas drilling/exploration and power generation.

Filtering these unique connectors is accomplished in one of two ways at Spectrum Control. We can add the required filtering to the back of the existing connector and thereby extend the length, or manufacture a new shell and then filter within that shell. This method can be utilized when the cost of the unfiltered connector is prohibitive due to the sole sourced situation in a particular connector series.



# Custom Filtered Connectors

## Connectors with Complex Schematics

Spectrum Control has the capability to offer filtered connectors with complex schematics such as double L (CLCL), double Pi (CLCLC), double T (LCLCL) filters, or transient voltage suppression devices. These products may be required when the system impedances are mismatched or when an extremely fast rise in insertion loss is needed.

**Spectrum Control is experienced in the manufacture of these complex schematics in all of our filter products.** Spectrum's engineering facility can use computer models to select the best filter type for the application.

## Plastic Commercial Connectors

Many manufacturers in the medical and high reliability commercial markets utilize plastic connectors that subsequently require filtering. Spectrum Control will filter plastic shell connectors.

This product requires special manufacturing techniques. The ground path for filtering is achieved either by using one of the connector pins or by adding an external ground strap to the metal collar.

Through the use of lower cost commercial components such as formed terminals, **Spectrum Control will minimize the cost of filtering this type connector.**

## Value-added Filtered Connectors

We are often approached by customers who have procured a large quantity of unfiltered connectors for a program and subsequently determined that some need to be filtered. **Instead of scrapping or returning these connectors at a large expense, appropriate EMI filters can be added by Spectrum Control.**

The addition of filters to an existing stock of connectors can provide significant cost savings. In many cases, standard unfiltered connectors are purchased in large volumes at a discounted price. By filtering a small quantity of these standard connectors, customers typically realize total cost savings and a reduced overall lead time.

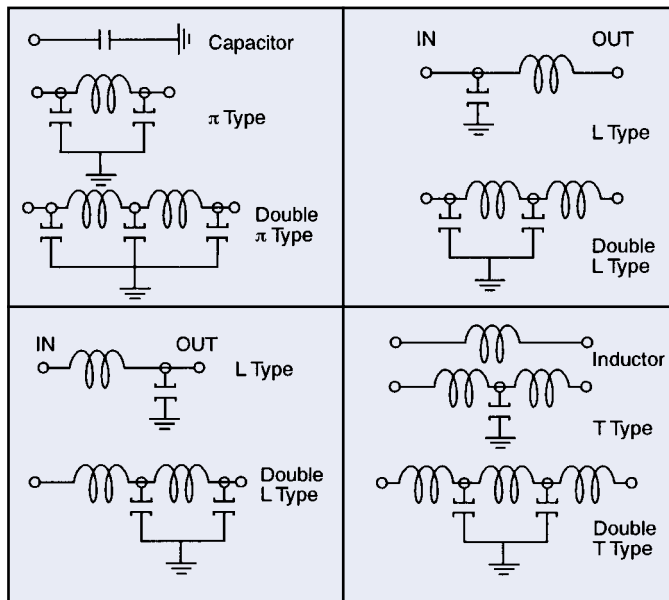

Plastic Commercial Connectors



# Quality Acceptance Test Specifications

All filtered connectors undergo extensive testing to assure that all product meets our high quality expectations. Many of the tests are performed 100% as routine and others are carried out on a sample basis when this is deemed more meaningful.

## Visual

The connectors shall be manufactured and processed in a careful and workmanlike manner in accordance with good design and sound practice. All connectors shall be checked 100% to insure dimensions are as shown in this catalog.

## Capacitance

Checked on 100% of the contacts per detailed specifications when measured @ 25°C, 1 KHz, 0.1 to 1.0VRMS. On insulated feed-thru lines, the maximum capacitance is 25 pF.

## Dissipation factor

4% maximum, checked 100% @ 25°C, 1KHz, 0.1 to 1.0VRMS

## Dielectric withstanding voltage

Performed on 100% of the filtered contacts. The test voltage unless otherwise specified will be 2.5 times the working voltage as specified at 25°C. This voltage will be applied for 1 to 5 seconds with the charging current limited to 50 milliamps.

## Insulation resistance

Performed on 100% of the filtered contacts at 25°C. The minimum acceptance level will be 1000 megohms at 25°C and 100 megohms at 125°C if required. This test will be carried out in accordance with MIL-STD-202 Method 302, test voltage of 100VDC or at rated voltage whichever is less.

## Insertion loss

Performed on a sample quantity of filtered contacts, minimum acceptance levels as specified by typical insertion loss graphs.

## Resistance to ground

The RDC on ground lines is 5 milliohms max.

## Marking

As a minimum, all connectors shall have the Spectrum part number, date code and logo. Upon request, customer specified marking can be incorporated into the manufacturing cycle.

## Special Testing

Spectrum has a fully qualified test laboratory and is willing to provide additional acceptance testing upon customers request, at minimal additional costs.

## Minimum Design Specifications

All of the filtered connectors are designed to meet minimum standards shown in table below.

## Environmental Performance

Test*	MIL-STD-1344		MIL-STD-202		Comments**
	Method	Condition	Method	Condition	
Vibration	-	-	204	G	30G for 10 to 2000 Cycles
Thermal Shock	-	-	107	A-1	Except Step 3 is +125 degrees C
Immersion	1016	-	104	A	-
Salt Spray	1001	-	101	B	-
Moisture Resistance	1002	II	106	-	Except Step 7
Shock	2004	-	213	I	-
Barometric Pressure	3001	-	105	C	125% rated voltage
Resistance to Solder Heat	-	-	210	B	-
Terminal Strength	-	-	211	A	The applied force shall be 5 lbs.
Contact Resistance	-	-	307	-	.0152 max.
Life	-	-	108	D	1000 hrs.
Durability	-	-	-	-	500 cycles
Solderability	-	-	208	-	-

\* All tests are performed per applicable MIL spec.

\*\* All parts will meet post test electricals (i.e. dielectric withstanding voltage, insulation resistance, capacitance, insertion loss and visual/mechanical).

# Quietshield™ Gaskets & Shielding

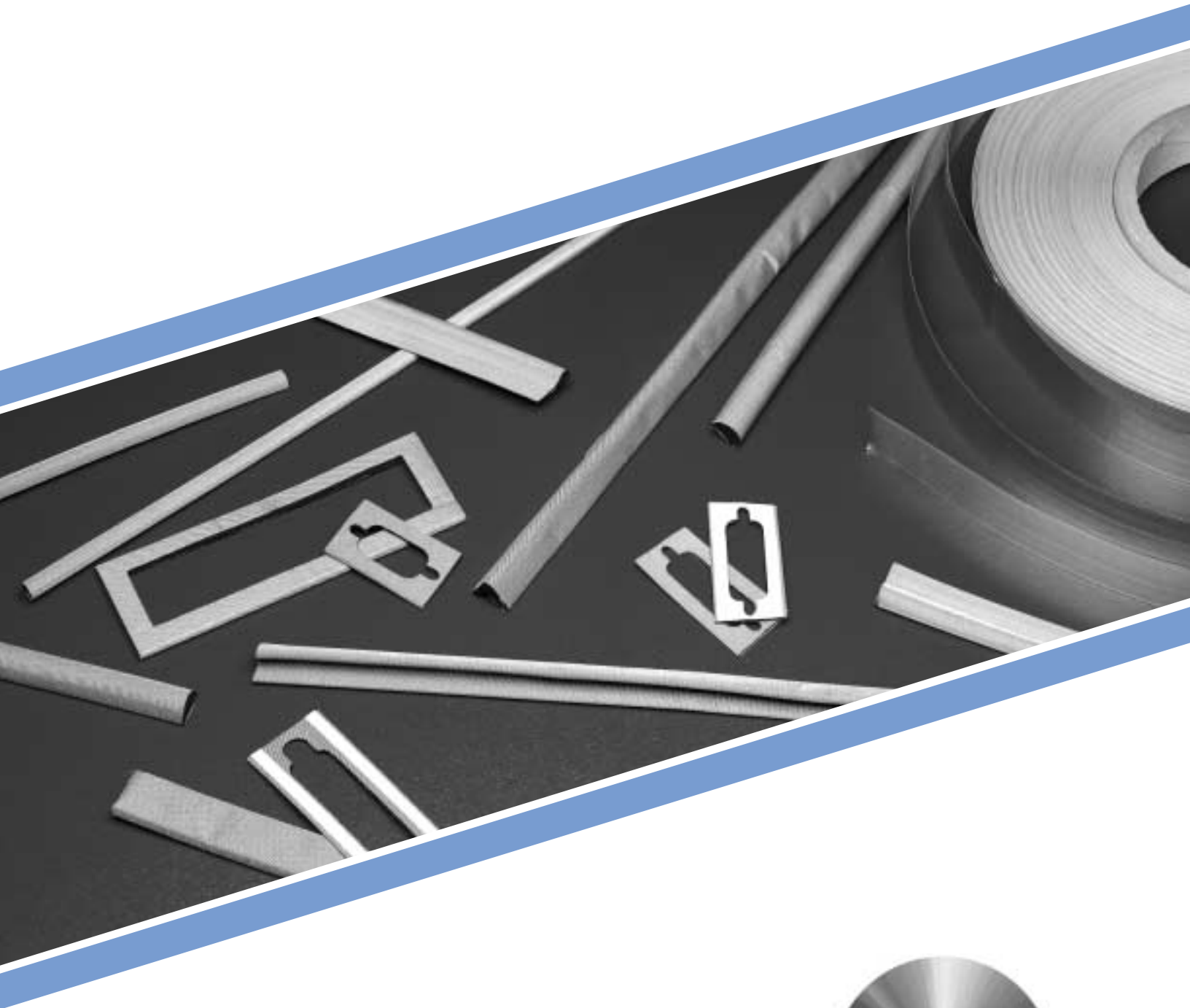

**ISO 9001**  
CERTIFIED



**SPECTRUM CONTROL INC.**  
A Control Products and Systems Company  
**Signal and Power Integrity Group**



## SPECTRUM CONTROL INC.

A Control Products and Systems Company

*Decades of advancing interconnections and signal conditioning technology gives Spectrum Control a uniquely effective perspective on EMI and its control. Since the best time to control noise is before it starts, we've developed a simulation capability that helps eliminate EMI problems at your earliest design stage, prior to board fabrication.*

*Quiet Board Noise Reduction Printed Circuit Boards are another innovative product from Spectrum Control. These shielded printed circuit boards utilize an enhanced Copper Polymer shield to provide the noise filtering effect of discrete bypass capacitors without added inductance. This unique board-coating technology eliminates the frustration of failing emissions certification, without resorting to multi-layer ground planes. All at real cost savings over other board-level fixes.*

*In combination with our Filtering, Shielding, and TVSS products, Spectrum Control can solve EMI problems while providing you with increased design flexibility, reduced time-to-market and peak system performance.*

<b>Index</b>	<b>Page</b>
<i>Shielding Theory and Introduction</i> .....	229
<i>Quietshield Gaskets</i> .....	230
<i>Quietshield "D" Profile Gaskets</i> .....	231
<i>Quietshield "P" Profile Gaskets</i> .....	231
<i>Clips</i> .....	231
<i>Quietshield "R" Profile Gaskets</i> .....	232
<i>Quietshield "L" Profile Gaskets</i> .....	232
<i>I/O Gaskets - "D"</i> .....	233
<i>Custom Shielding Products</i> .....	234
<i>EMI Shielding Tapes</i> .....	235
<i>Part Number Index</i> .....	236



# Quietshield™ Shielding Products . . .



Gaskets



I/O Gaskets - "D"

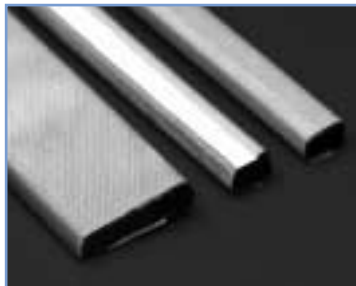

Quietshield "R" Profile Gaskets

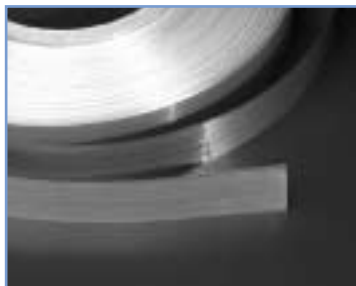

EMI Shielding Tapes

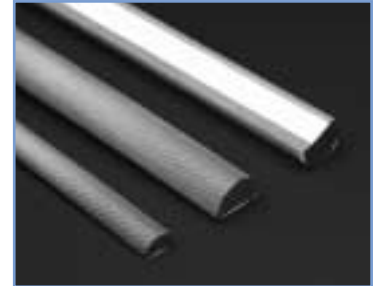

Quietshield "D" Profile Gaskets



Quietshield "P" Profile Gaskets



Quietshield "L" Profile Gaskets

# Shielding Theory and Introduction

## Shielding Theory

Electromagnetic shielding is used to prevent electromagnetic signals such as radio signals from leaving or entering a box or enclosure. Signals inadvertently emitted by an electronic device can cause distortion or interruption in normal radio communications in a localized area. This is the basis of most laws and regulations concerning electromagnetic interference. In addition, normal radio signals can cause unprotected electronic devices to malfunction. Depending on the devices' function, a malfunction in the device could be a minor inconvenience such as static on a radio, or life threatening such as the malfunction of a life support system at a hospital.

## Introduction

The electromagnetic shield in most cases is the electronic housing itself. The housing/shield forms a metal cage around the electronic circuits in a device. Most of the electromagnetic signal is absorbed with a small portion (3 to 10 dB) of the signal reflected off the metal housing. Most of the absorbed signal creates alternating currents at radio frequencies travels on the surface of metal. This allows the electromagnetic shield to keep signals from outside the enclosure on the outside of the shield and signals from inside signals on the inside of the shield.

The shield will continue to function as long as there are no holes in the electromagnetic shield which would allow the currents to flow from one side of the shield to the other. Holes are a necessity in an electronic enclosure. Connectors, wires, and cables are needed to transmit information to and from electronic devices. Doors and covers are needed to get access to components to maintenance, service, and keypads may also be required. The problem is that all of these items cause openings in the shield which reduce the performance of the shield.

Special devices such as shielding gaskets, shielding ventilation panels, shielded filtered connectors, and shielded switches minimize the effect of a hole in the shield.

The length of the hole and wavelength of the signal that needs to be shielded are the major factors determining the shielding effectiveness of an electronic enclosure. The distance between spotwelds, or screws which hold a metal housing together count as long narrow holes. Higher frequencies (lower wavelengths) flow more easily through smaller holes, and so the highest frequency needed to be shielded is the frequency of concern when designing shielding.

Aperture versus frequency charts can give a rough estimate of the shielding effectiveness of a metallic electronic housing.

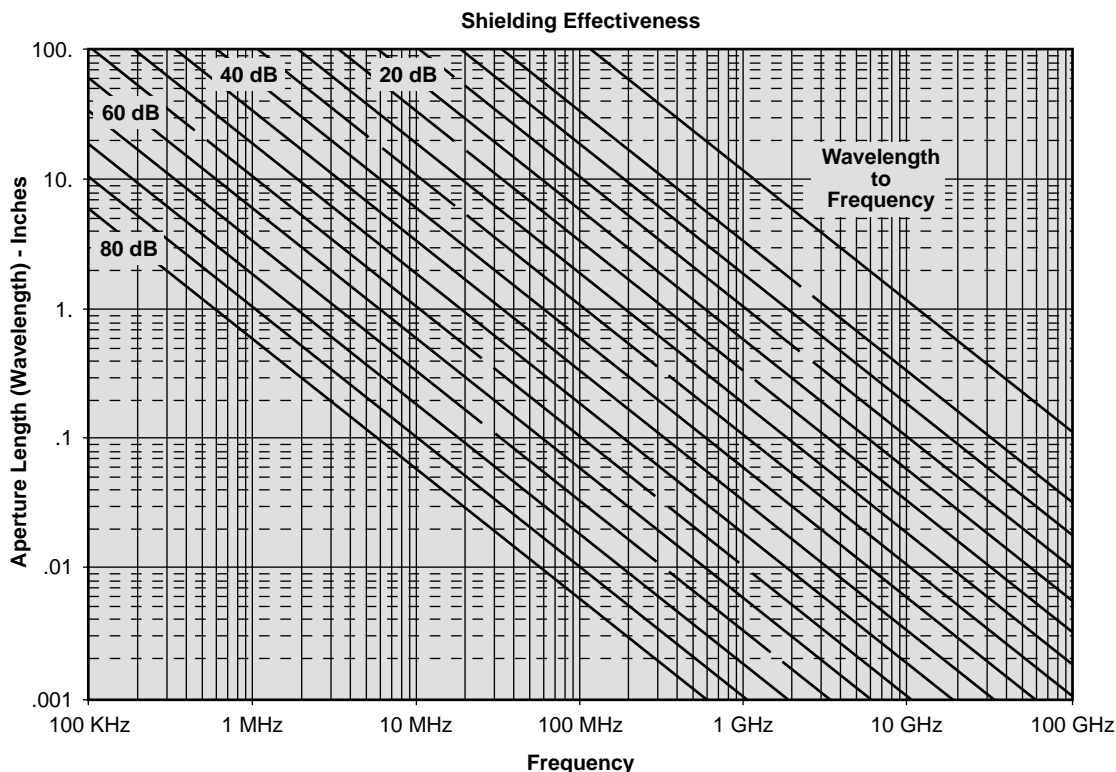

# Quietshield™ Gaskets



## Features

- Maintain shielding effectiveness across seams or gaps
- Shielding Effectiveness (SE) of 70 - 100 dB between 1 MHz to 18 GHz
- Exclusive Quiet Contact provides instantaneous shielding effectiveness upon initial contact of gasket
- Flexible and conformable
- No creasing or tearing
- Lightweight material

## Profile Gaskets

Quietshield EMI/RFI Gaskets maintain shielding effectiveness (SE) across a seam or gap in the electronic equipment's shielding material. They consist of metallized fabric wrapped around a neoprene elastomer core. This provides a low cost solution which allows you to utilize many material combinations and product designs never before practical.

Quietshield gaskets provide unique solutions to your most stringent shielding, grounding, ESD and packaging requirements. It's the cost-effective avenue for creativity in design. Profile gaskets are currently available in four shapes: "D", "R", "L", and "P".

Spectrum Control's proprietary manufacturing method for making profile shielding gaskets is also ideally suited to custom profiles. New shapes and sizes can be manufactured with minimal lead times and low tooling costs. Changes can be easily made to the rubber core material, type of fabric or foil covering, and adhesive systems. Shielding specialists are at your disposal to help you with your custom designs. These specialists use design for manufacturability concepts to produce designs which meet your specific requirements at a reasonable cost.

## Mounting Styles

The mounting style available for most profile gaskets is pressure sensitive adhesive.

Pressure sensitive adhesives allow simple place and press mounting on smooth and clean metal surfaces. The parts can be cut to the desired length with common scissors or ordered to the exact length required. The adhesive provides high strength with aggressive initial tack, which increases in strength over time or after exposure to elevated temperatures.

## I/O Gaskets

Spectrum Control offers a complete line of standard and custom I/O connector Electromagnetic Shielding Gaskets. I/O gaskets are flat gaskets used to provide a ground contact between a metal connector and the electronic enclosure or mating connector. They insure that the shield remains continuous from the input/output cable to the electronic enclosure.

## Sample Kit

Quietshield sample kits are available from Spectrum Control Inc. Order number KIT-QSHIELD-57.

Test	ASTM Test	Performance
Shielding Effectiveness, dB		70-100
Compression Set %	D3574	7.9
Compression Load Deflection, PSI	D3574	15
Compression at Max Load		60%
Water Absorption (Foam Only) %	D1667	5.8
Abrasion Resistance, 3,000 Cycles	D3885	Excellent
Ultra Violet Exposure	D750	No Visible Change
Fungus Exposure	G21	Small Growth
Operating Temperature C	D746	-40 to +90
Flammability Rating	UL94	VO
Conductivity, OHMS/SQ		
Unexposed		0.2
Weathered (100 HRS)		0.3
Fungus		0.2
Salt		0.2
DC Conductivity		.2 Ohms/SQ
Tensile Strength		80 lb/in

# Quietshield™ “D” and “P” Profile Gaskets



## “D” Profile Gasket Features

- Exclusive Quiet Contact provides instantaneous shielding effectiveness upon initial contact
- Provides superior Shielding Effectiveness (SE) of 70 dB between 1 MHz to 18 GHz
- Non-conductive adhesive is standard; conductive adhesive is available
- Ni/Ag metallized nylon fabric wrapped around a foam compression core
- Available in any length, six foot maximum

Dimensions		Attachment	Length	Old Part Number	New Catalog Number
A	B				
.060 (1.52)	.150 (3.81)	Non-conductive adhesive	6 ft.	267513-2	57D13-1506-7200
.090 (2.29)	.090 (2.29)	Non-conductive adhesive	6 ft.	93941-2	57D13-0909-7200
.120 (3.05)	.150 (3.81)	Non-conductive adhesive	6 ft.	93942-2	57D13-1512-7200
.120 (3.05)	.250 (6.35)	Non-conductive adhesive	6 ft.	267440-4	57D13-2512-7200
.140 (3.56)	.250 (6.35)	Non-conductive adhesive	6 ft.	93943-2	57D13-2514-7200
.250 (6.35)	.375 (9.53)	Non-conductive adhesive	6 ft.	93944-2	57D13-3725-7200

Dimensions in inches (mm)

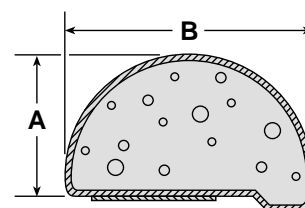

## “P” Profile Gasket Features

- Exclusive Quiet Contact provides instantaneous shielding effectiveness upon initial contact
- Provides superior Shielding Effectiveness (SE) of 70 dB at between 1 MHz to 18 GHz
- Dual-durometer core provides consistent part shape and function
- Non-conductive adhesive is standard; conductive adhesive is available
- Nickel/copper metallized polyester fabric wrapped around a low compression set neoprene core
- Ni/Ag metallized nylon fabric wrapped around a foam compression core
- Available in any length, six foot maximum

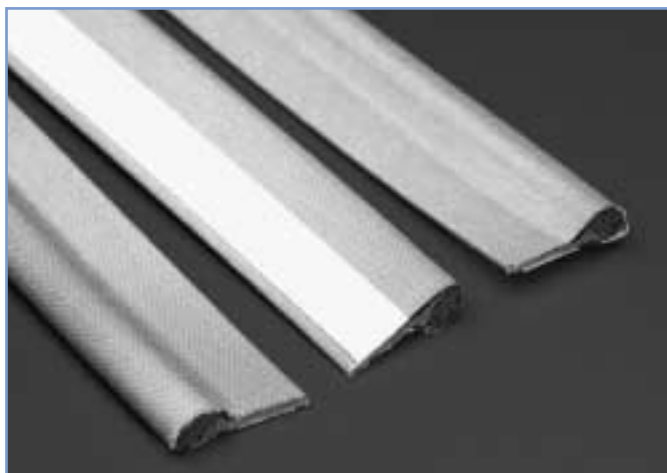

Dimensions		Attachment	Length	Old Part Number	New Catalog Number
A	B				
.160 (4.06)	.520 (13.21)	Non-conductive adhesive	6 ft.	267416-1	57P13-5216-7200
.160 (4.06)	.520 (13.21)	Conductive adhesive	6 ft.	267416D-72	57P12-5216-7200

Dimensions in inches (mm)

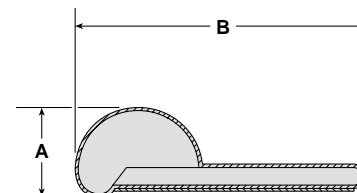

## Clips

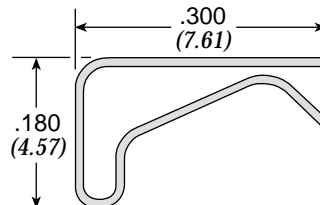
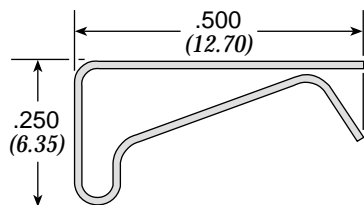

# Quietshield™ “R” and “L” Profile Gaskets

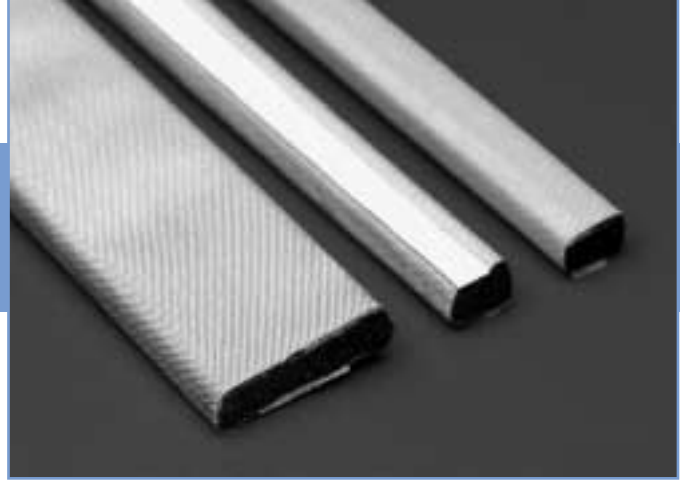

## “R” Profile Gasket Features

- Exclusive Quiet Contact provides instantaneous shielding effectiveness upon initial contact
- Provides superior Shielding Effectiveness (SE) of 70 dB at between 1 MHz to 18 GHz
- Non-conductive adhesive is standard; conductive adhesive is available
- Nickel/copper metallized polyester fabric wrapped around a low compression set neoprene core
- Ni/Ag metallized nylon fabric wrapped around a foam compression core
- Available in any length, six foot maximum

Dimensions		Attachment	Length	Old Part Number	New Catalog Number
A	B				
.040 (1.02)	.400 (10.16)	Non-conductive adhesive	6 ft.	267415-1	57R13-4004-7200
.040 (1.02)	.200 (5.08)	Non-conductive adhesive	6 ft.	267454-1	57R13-2004-7200
.062 (1.57)	.200 (5.08)	Non-conductive adhesive	6 ft.	267517-1	57R13-2006-7200
.080 (2.03)	.160 (4.06)	Non-conductive adhesive	6 ft.	267455-1	57R13-1608-7200
.120 (3.05)	.400 (10.16)	Non-conductive adhesive	6 ft.	267410-1	57R13-4012-7200
.125 (3.18)	.250 (6.35)	Non-conductive adhesive	6 ft.	93946-2	57R13-2512-7200
.130 (3.30)	.190 (4.83)	Non-conductive adhesive	6 ft.	93945-2	57R13-1913-7200
.130 (3.30)	.500 (12.70)	Non-conductive adhesive	6 ft.	93947-2	57R13-5013-7200
.160 (4.06)	.160 (4.06)	Non-conductive adhesive	6 ft.	267414-1	57R13-1616-7200
.200 (5.08)	.200 (5.08)	Non-conductive adhesive	6 ft.	267411-1	57R13-2020-7200
.220 (5.59)	.400 (10.16)	Non-conductive adhesive	6 ft.	267408-1	57R13-4022-7200
.375 (9.53)	.375 (9.53)	Non-conductive adhesive	6 ft.	267413-1	57R13-3737-7200
.400 (10.16)	.510 (12.95)	Non-conductive adhesive	6 ft.	267409-1	57R13-5140-7200
.250 (6.35)	.500 (12.70)	Non-conductive adhesive	6 ft.	267412-1	57R13-5025-7200

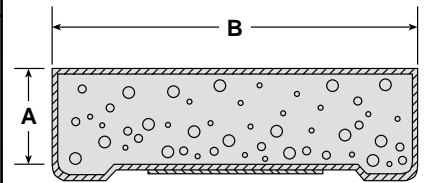

Dimensions in inches (mm)

## “L” Profile Gasket Features

- Provides superior Shielding Effectiveness (SE) of 70 dB at between 1 MHz to 18 GHz
- Conductive adhesive is standard
- Nickel/copper metallized polyester fabric wrapped around a low compression set neoprene core
- Ni/Ag metallized nylon fabric wrapped around a foam compression core
- Available in any length, six foot maximum



Dimensions		Attachment	Length	Old Part Number	New Catalog Number
A	B				
.395 (10.03)	.430 (10.92)	Conductive adhesive	6 ft.	93949-2	57L12-4339-7200
.673 (17.09)	.578 (14.68)	Conductive adhesive	6 ft.	267205-2	57L12-5767-7200

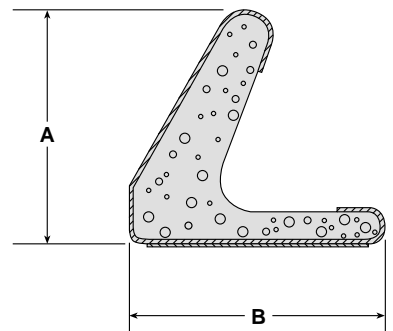

Dimensions in inches (mm)

# I/O Gaskets - "D"

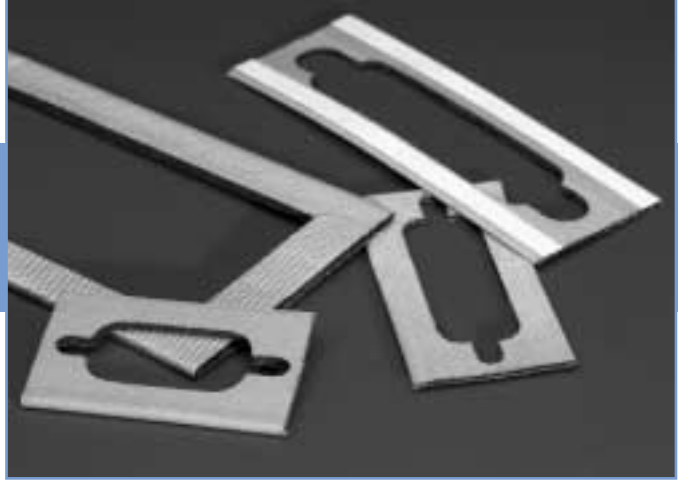

## Features

- Three thickness styles:
  - Die-cut, non-woven Ni/Cu metalized polyester fabric
  - .040" thick woven fabric around neoprene
  - .070" thick woven fabric around neoprene
- Each style available in "D" connector shell sizes 1-5 (9, 15, 25, 37, 50 position)
- Provides superior Shielding Effectiveness (SE) of 70 dB at between 1 MHz to 18 GHz
- Lightweight

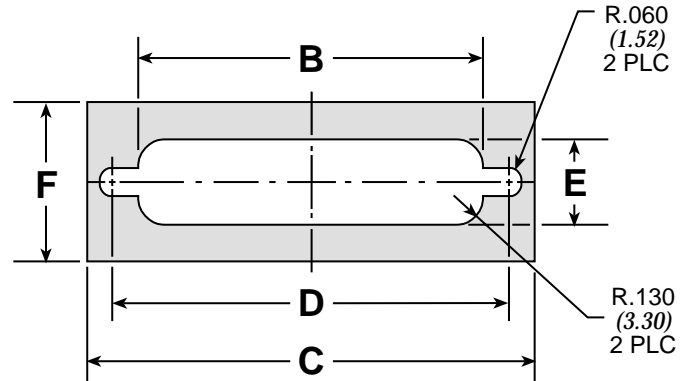

Shell Size	Thickness A	Dimensions					Fabric Type	Old Catalog Number	New Catalog Number
		B	C	D	E	F			
1	0.012 (0.30)	0.746 (18.95)	1.213 (30.81)	0.984 (24.99)	0.400 (10.16)	0.750 (19.05)	Non woven	267250-1	57F01-D112-1275
	0.040 (1.02)						Woven	267251-1	57F11-D140-1275
	0.070 (1.78)						Woven	267251-2	57F11-D170-1275
2	0.012 (0.30)	1.074 (27.28)	1.541 (39.14)	1.312 (33.32)	0.400 (10.16)	0.750 (19.05)	Non woven	267250-2	57F01-D212-1575
	0.040 (1.02)						Woven	267252-1	57F11-D240-1575
	0.070 (1.78)						Woven	267252-2	57F11-D270-1575
3	0.012 (0.30)	1.614 (41.00)	2.088 (53.04)	1.852 (47.04)	0.400 (10.16)	0.750 (19.05)	Non woven	267250-3	57F01-D312-2075
	0.040 (1.02)						Woven	267253-1	57F11-D340-2075
	0.070 (1.78)						Woven	267253-2	57F11-D370-2075
4	0.012 (0.30)	2.266 (57.56)	2.720 (69.09)	2.500 (63.50)	0.400 (10.16)	0.750 (19.05)	Non woven	267250-4	57F01-D412-2775
	0.040 (1.02)						Woven	267254-1	57F11-D440-2775
	0.070 (1.78)						Woven	267254-2	57F11-D470-2775
5	0.012 (0.30)	2.158 (54.81)	2.63 (66.80)	2.406 (61.11)	0.500 (12.70)	0.850 (21.59)	Non woven	267250-5	57F01-D512-2685
	0.040 (1.02)						Woven	267255-1	57F11-D540-2685
	0.070 (1.78)						Woven	267255-2	57F11-D570-2685

Dimensions in inches (mm)

# Custom Shielding Products

## Custom I/O Gaskets

The manufacturing method used to make the standard I/O gaskets can be easily adapted to make custom designs. Various widths and thicknesses can be made with minimal tooling changes. Complicated cutout patterns are not a problem, and in many cases a large I/O gasket with a pattern of cutouts can economically replace several single I/O gaskets. The materials used to construct the I/O gasket can also be changed to suit specific customer requirements of cost, or performance. Spectrum has an experienced design staff available to assist in your custom I/O requirements.

## Custom Laminates

QUIETSHIELD™ Custom Laminates from Spectrum are inexpensive shields usually used inside an electronic enclosure to shield an individual circuit board, or even a specific component. In most cases, a simple inexpensive shielding laminate can provide all the shielding required without having to modify or redesign the enclosure. Shielding laminates are also a good way to separate individual circuit boards or components which interfere with each other. Shielding laminates come in all sizes and can be custom made to your specifications, or our skilled shielding design team can create a design to suit your specific requirements.

## Laminate Types

- **Simple shields** – These laminates consist of a metalized fabric or metal foil, and are usually laminated on one side with PVC film or similar backing to prevent the shield from shorting the circuit board that the laminate is attached to. The laminate is usually placed over a circuit board, and attached to ground with screws or conductive adhesive. These shields usually give shielding performances from 3 to 10 dB. In many cases, this is enough to solve problems between circuit boards.
- **Shielding patches** – Die cut tapes with the same shape as cutouts in an electronic enclosure. The patches form an easy to remove cover over a hole in an electronic enclosure. Holes can be punched out in an enclosure for connectors, cables, or other components which will be added in future upgrades or versions of a device. The die cut patch covers the hole and provides a dust shield at the hole which can be easily removed in the future.

- **Shielding envelopes** – Similar to a paper business envelope except that they are made out of a conductive cloth or foil. The envelope is designed so that a circuit board can be slipped inside, and a flap with conductive adhesive closed behind the circuit board. Cutouts in the envelope are strategically placed for connectors, mounting screws, heat sinks, etc. The result is a flexible, low cost electronic enclosure for a circuit board. The main application is for electronic equipment with plastic housings which need to meet higher shielding requirements. In many cases, redesign of the plastic housing to a metal housing with shielding gaskets is expensive and time consuming, while the shielding envelope is inexpensive and quick. Another application is in shielding individual circuit boards from each other with the same electronic enclosure.

- **Electronic component shields** – Shield laminates can be made into a shield cover for an individual component or circuit on the circuit board. The shield laminate can be screwed in place, or adhered with a conductive adhesive. Spectrum has also developed a special component shield - the hybrid shield. The hybrid shield consists of a flat laminate shield with QUIETSHIELD™ gaskets mounted around its perimeter to form a shield can. The hybrid shield can be placed over a component on a circuit board to form a shield. The lid or cover of the enclosure supplies the force to ensure that the hybrid can also be easily removed to get at the component or circuit being shielded. The hybrid shield is ideal for a small enclosure with limited space which may need frequent adjustment of maintenance to noisy circuits.

# EMI Shielding Tapes

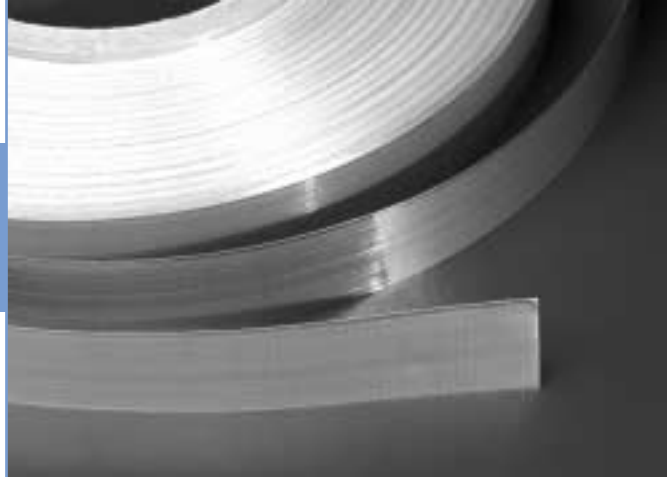

## Features

- Tin plated copper foil contact tape with tape mask
- Metallized woven fabric with Shielding Effectiveness (SE) of 70 dB; 1 MHz to 18 GHz
- Conductive or non-conductive adhesive
- Standard and custom widths

## Shielding Tapes

Shielding tapes are usually used to cover up a seam on an electronic enclosure. Standard tape is available as metallized fabric with conductive adhesive. Options include non-conductive adhesive and/or custom widths. Shield laminates in the form of tapes can be wrapped around a cable to form a custom cable shield. The metallized fabric is ideal for this application due to its inherent flexibility. The shielding tape can be laminated on the inside with a conductive adhesive to hold the wrap in place. A non-conductive or abrasion resistant tape can then be wrapped over the shield to prevent shorting or abrasion damage.

## Foil Tape

Spectrum offers a Foil Contact Paint Mask Tape as an accessory to its line of QUIETSHIELD™ profile gaskets. This tape consists of a thin tin plated copper foil with a conductive adhesive on one side and a paint mask on the other. The tape can be applied to the bare metal surface of an electronic enclosure before painting. After painting, the paint mask is removed providing a clean contact surface for mounting and contact with the shielding gaskets. The tape is also useful in providing an interface between reactive metal surfaces such as aluminum or zinc (galvanized) and the shielding gaskets.

EMI Shielding Tapes				
Tape	Width	Length	Part Numbers	Catalog Numbers
Fabric	1 in.	200 ft.	267297-1	57T11-0100-0200
Fabric	2 in.	200 ft.	267297-2	57T11-0200-0200
Fabric	3.625 in.	200 ft.	267297-3	57T11-0362-0200
Fabric	4 in.	200 ft.	267297-4	57T11-0400-0200
Foil	.5 in.	330 ft.	267325-2	57T12-0050-0330
Foil	.75 in.	330 ft.	267325-1	57T12-0075-0330

# Gaskets and Shielding Part Number Index

Old Part Number	New Catalog Number	Page Number
93941	57D13-0909-7200	231
93942	57D13-1512-7200	231
93943	57D13-2514-7200	231
93944	57D13-3725-7200	231
93945	57R13-1913-7200	232
93946	57R13-2512-7200	232
93947	57R13-5013-7200	232
93949	57L12-4339-7200	232
267205	57L12-5767-7200	232
267250-X	57F01-xxxx-xxxx	233
267251	57F11-D1xx-1275	233
267252	57F11-D2xx-1575	233
267253	57F11-D3xx-2075	233
267254	57F11-D4xx-2775	233
267255	57F11-D5xx-2685	233
267297	57T11-0xxx-0200	235
267303	57R15-1913-xxxx	232 (reference)
267304	57R15-2512-xxxx	232 (reference)

Old Part Number	New Catalog Number	Page Number
267305	57R16-5013-xxxx	232 (reference)
267325	57T12-00xx-0330	235
267408	57R13-4022-7200	232
267409	57R13-5140-7200	232
267410	57R13-4012-7200	232
267411	57R13-2020-7200	232
267412	57R13-5025-7200	232
267413	57R13-3737-7200	232
267414	57R13-1616-7200	232
267415	57R13-4004-7200	232
267416	57P13-5216-7200	231
267416D-72	57P12-5216-7200	231
267440	57D13-2512-7200	231
267454	57R13-2004-7200	232
267455	57R13-1608-7200	232
267513	57D13-1506-7200	231
267517	57R13-2006-7200	232

**Note:** This part number index lists all cataloged parts by base number only. Complete part numbers (with prefixes and/or suffixes) are shown on the pages indicated.

# Military Cross Reference Qualified Components

## MIL-F-15733

Military Designation MIL-F-15733	Spectrum Part Number
/23-0001	51-390-001
/23-0002	51-390-002
/23-0003	51-390-003
/23-0004	51-390-004
/23-0005	51-390-301
/23-0006	51-390-302
/23-0007	51-390-005
/23-0008	51-390-006
/23-0009	51-390-007
/23-0010	51-390-008
/23-0011	51-390-303
/23-0012	51-390-304
/23-0013	51-390-009
/23-0014	51-390-010
/23-0015	51-390-011
/23-0016	51-390-012
/23-0017	51-390-305
/23-0018	51-390-306
/23-0019	51-390-013
/23-0020	51-390-014
/23-0021	51-390-015
/23-0022	51-390-016
/23-0023	51-390-307
/23-0024	51-390-308
/23-0025	51-390-017
/23-0026	51-390-018
/23-0027	51-390-019
/23-0028	51-390-020
/23-0029	51-390-309
/23-0030	51-390-310
/23-0031	51-390-021
/23-0032	51-390-022
/23-0033	51-390-023
/23-0034	51-390-024
/23-0035	51-390-311
/23-0036	51-390-312
/23-0037	51-390-025
/23-0038	51-390-026
/23-0039	51-390-027
/23-0040	51-390-028
/23-0041	51-390-313
/23-0042	51-390-314
/23-0043	51-390-029
/23-0044	51-390-030
/23-0045	51-390-031
/23-0046	51-390-032
/23-0047	51-390-315
/23-0049	51-390-033
/23-0050	51-390-034
/23-0051	51-390-035
/23-0052	51-390-036
/23-0053	51-390-317
/23-0054	51-390-318
/23-0055	51-390-037
/23-0056	51-390-038
/23-0057	51-390-039
/23-0058	51-390-040

Military Designation MIL-F-15733	Spectrum Part Number
/23-0059	51-390-319
/23-0060	51-390-320
/24-0001	51-353-064
/24-0002	51-353-065
/24-0003	51-444-049
/24-0004	51-444-050
/24-0005	51-353-066
/24-0006	51-353-067
/24-0007	51-444-051
/24-0008	51-444-060
/24-0009	51-353-068
/24-0010	51-353-069
/24-0011	51-353-070
/24-0012	51-353-071
/24-0013	51-353-072
/24-0014	51-353-073
/24-0015	51-353-074
/24-0016	51-353-075
/24-0017	51-444-052
/24-0018	51-444-053
/24-0019	51-444-054
/24-0020	51-444-055
/24-0021	51-444-056
/24-0022	51-444-057
/24-0023	51-444-058
/24-0024	51-444-059
/25-0002	51-311-308
/25-0003	51-353-053
/25-0004	51-311-309
/25-0005	51-353-054
/25-0006	51-311-310
/25-0007	51-382-603
/25-0008	51-353-055
/25-0009	51-353-056
/25-0010	51-311-311
/25-0011	51-353-057
/25-0012	51-382-604
/25-0013	51-444-037
/25-0014	51-311-354
/25-0015	51-444-038
/25-0016	51-311-355
/25-0017	51-444-039
/25-0018	51-311-356
/25-0019	51-382-608
/25-0020	51-444-040
/25-0021	51-444-041
/25-0022	51-311-357
/25-0023	51-444-042
/25-0024	51-382-609
/26-0001	51-353-076
/26-0002	51-353-336
/26-0003	51-353-077
/26-0004	51-353-078
/26-0005	51-311-312
/26-0006	51-353-079
/26-0007	51-353-080
/26-0008	51-351-603
/26-0009	51-311-313

Military Designation MIL-F-15733	Spectrum Part Number
/26-0010	51-353-081
/26-0011	51-311-314
/26-0012	51-351-604
/26-0013	51-444-043
/26-0014	51-353-424
/26-0015	51-444-044
/26-0016	51-444-045
/26-0017	51-311-358
/26-0018	51-444-046
/26-0019	51-444-047
/26-0020	51-351-625
/26-0021	51-311-359
/26-0022	51-444-048
/26-0023	51-311-360
/26-0024	51-351-626
/27-0001	51-320-013
/27-0002	51-320-014
/27-0003	51-323-313
/27-0004	51-321-312
/27-0005	51-320-015
/27-0006	51-320-016
/27-0007	51-323-314
/27-0008	51-320-017
/27-0009	51-320-018
/27-0010	51-321-313
/27-0011	51-323-003
/27-0012	51-323-004
/27-0013	51-321-314
/27-0014	51-322-009
/27-0015	51-322-010
/27-0016	51-321-606
/27-0017	51-321-607
/27-0018	51-321-608
/27-0019	51-320-019
/27-0020	51-320-020
/27-0021	51-323-315
/27-0022	51-321-315
/27-0023	51-321-609
/27-0026	54-310-040
/28-0001	51-712-014
/28-0002	51-712-028
/28-0003	Superseded by /61-0014
/28-0004	51-712-060
/33-0001	51-707-006
/33-0002	51-707-007
/34-0001	51-322-016
/34-0002	51-322-017
/34-0003	51-311-327
/34-0004	51-321-328
/34-0005	51-321-329
/34-0006	51-321-330
/34-0007	51-353-207
/34-0008	51-353-208
/34-0010	51-311-007
/34-0011	51-320-058
/34-0013	51-320-060

# Military Cross Reference Qualified Components

## MIL-F-15733 (cont'd)

Military Designation MIL-F-15733	Spectrum Part Number
/34-0014	51-311-340
/34-0015	51-444-005
/34-0016	51-444-105
/34-0017	51-444-016
/34-0018	51-444-106
/34-0020	51-320-061
/34-0021	51-320-062
/34-0029	51-320-063
/34-0030	51-444-027
/34-0031	51-321-391
/34-0035	54-370-030
/34-0037	54-310-039
/38-0001	51-343-018
/38-0002	51-343-028
/38-0003	51-353-422
/38-0004	51-359-021
/38-0005	51-359-024
/38-0006	51-343-034
/38-0008	51-359-050
/39-0001	51-353-148
/39-0002	51-353-149
/39-0003	51-353-150
/39-0004	51-353-151
/39-0005	51-353-152
/39-0006	51-353-153
39-0007	51-353-154
/39-0008	51-353-155
/39-0009	51-353-156
/39-0010	51-353-157
/39-0011	51-353-344
/39-0012	51-353-345
/39-0013	51-353-223
/39-0014	51-353-287
/39-0015	51-353-418
/39-0016	51-311-346
/39-0017	51-311-347
/39-0018	51-311-348
/40-0001	51-704-002
/43-0001	51-719-023
/43-0002	51-712-055
/44-0001	51-744-003
/44-0002	51-762-005
/44-0003	51-762-006
/46-0001	51-709-004
/48-0001	51-385-038
/48-0002	51-385-040
/48-0003	51-385-049
/48-0005	51-385-050
/49-0001	51-359-053
/49-0003	51-359-034
/49-0004	51-359-035
/49-0006	51-359-044
/49-0007	51-359-055
/49-0008	54-370-032
/49-0010	54-370-034
/51-0001	51-703-007
/51-0002	51-750-313

## MIL-F-28861

Military Designation MIL-F-28861	Spectrum Part Number
/1-001	51-359-081
/1-002	54-367-049
/1-003	51-359-082
/1-004	54-367-050
/1-005	51-359-083
/1-006	54-367-051
/1-007	51-359-084
/1-008	54-367-052
/1-009	51-359-085
/1-010	54-367-053
/1-011	51-359-086
/1-012	54-367-054
/1-013	51-359-087
/1-014	54-367-055
/1-015	51-359-088
/1-016	54-367-056
/1-017	51-359-089
/1-018	54-367-057
/1-019	51-359-090
/1-020	54-367-058
/1-021	51-359-122
/1-022	54-367-085
/1-023	51-359-123
/1-024	54-367-086
/1-025	51-359-124
/1-026	54-367-087
/1-031	51-359-125
/1-032	54-367-088
/1-033	51-359-126
/1-034	54-367-089
/1-035	51-359-127
/1-036	54-367-090
/2-001	51-311-010
/2-002	51-311-011
/2-003	51-311-365
/2-004	51-311-012
/2-005	51-311-013
/2-006	51-311-366
/2-007	51-311-014
/2-008	51-311-015
/2-009	51-311-367
/2-010	51-311-016
/2-011	51-311-017
/2-012	51-311-368
/2-013	51-311-018
/2-014	51-311-019
/2-015	51-311-369
/2-016	51-311-020
/2-017	51-311-021
/2-018	51-311-370
/2-019	51-311-022
/2-020	51-311-023
/2-021	51-311-371
/2-022	51-311-024
/2-023	51-311-025
/2-024	51-311-372
/3-001	51-390-044
/3-002	51-390-045

# Military Cross Reference Qualified Components

## MIL-F-28861 (cont'd)

Military Designation MIL-F-28861	Spectrum Part Number
/3-003	51-390-321
/3-004	51-390-046
/3-005	51-390-047
/3-006	51-390-322
/3-007	51-390-048
/3-008	51-390-049
/3-009	51-390-323
/3-010	51-390-050
/3-011	51-390-051
/3-012	51-390-324
/3-013	51-390-052
/3-014	51-390-053
/3-015	51-390-325
/3-016	51-390-054
/3-017	51-390-055
/3-018	51-390-326
/3-019	51-390-056
/3-020	51-390-057
/3-021	51-390-327
/3-022	51-390-058
/3-023	51-390-059
/3-024	51-390-328
/3-025	51-390-060
/3-026	51-390-061
/3-027	51-390-329
/3-028	51-390-062
/3-029	51-390-063
/3-030	51-390-330
/3-031	51-390-064
/3-032	51-390-065
/3-033	51-390-331
/3-034	51-390-066
/3-035	51-390-067
/3-036	51-390-332
/5-001	51-311-026
/5-002	51-311-027
/5-003	51-311-374
/5-004	51-311-028
/5-005	51-311-029
/5-006	51-311-375
/5-007	51-311-030
/5-008	51-311-031
/5-009	51-311-376
/5-010	51-311-032
/5-011	51-311-033
/5-012	51-311-377
/5-013	51-311-034
/5-014	51-311-035
/5-015	51-311-378
/5-016	51-311-036
/5-017	51-311-037
/5-018	51-311-379
/5-019	51-311-038
/5-020	51-311-039
/5-021	51-311-380
/5-022	51-311-040
/5-023	51-311-041
/5-024	51-311-381

## DSCC 84084 Product

DSCC Designation	Spectrum Part Number
84084-001	54-310-042
84084-004	51-320-162
84084-005	51-320-163
84084-006	51-320-164
84084-007	51-320-165
84084-008	51-320-166
84084-009	51-320-167
84084-010	51-320-168
84084-011	51-320-169
84084-013	51-321-398
84084-014	51-321-399
84084-015	51-321-400
84084-016	51-321-401

## MIL-C-11015

/32 CK#	Spectrum Part Number
CK99BW502M	SCI-9900-502AP
CK99BW272M	SCI-9910-272AQ
CK99BW101M	SCI-9920-101T
CK99BW501M	SCI-9920-501K
CK99BW122M	SCI-9920-122J

# Spectrum Control/AMP Part Number Cross Reference

AMP Part Number	Spectrum Part Number
1124033-1	56-407-001
1124034-1	56-403-001
1124082-1	56-614-001
1124174-1	56-413-001
1124175-1	56-423-001
1-842900-3	56-702-001-LI
1-842900-0	56-702-005-LI
1-842900-1	56-702-008-LI
1-842900-2	56-702-008-LI
1-842900-4	56-702-XXX-LI**
1-842901-3	56-712-001-LI
1-842901-0	56-712-005-LI
1-842901-1	56-712-008-LI
1-842901-2	56-712-008-LI
1-842901-4	56-712-XXX-LI**
1-842902-3	56-722-001-LI
1-842902-0	56-722-005-LI
1-842902-1	56-722-009-LI
1-842902-2	56-722-009-LI
1-842902-4	56-722-XXX-LI**
1-842903-3	56-732-001-LI
1-842903-0	56-732-005-LI
1-842903-1	56-732-007-LI
1-842903-2	56-732-007-LI
1-842903-4	56-732-XXX-LI**
1-842904-3	56-742-001-LI
1-842904-0	56-742-005-LI
1-842904-1	56-742-007-LI
1-842904-2	56-742-007-LI
1-842904-4	56-742-XXX-LI**
1-842905-3	56-704-001-LI
1-842905-0	56-704-005-LI
1-842905-1	56-704-008-LI
1-842905-2	56-704-008-LI
1-842905-7	56-704-XXX**
1-842905-4	56-704-XXX-LI**
1-842906-3	56-714-001-LI
1-842906-0	56-714-005-LI
1-842906-1	56-714-007-LI
1-842906-2	56-714-007-LI
1-842906-4	56-714-XXX-LI**
1-842907-3	56-724-001-LI
1-842907-0	56-724-005-LI
1-842907-1	56-724-009-LI
1-842907-2	56-724-009-LI
1-842907-4	56-724-XXX-LI**
1-842908-3	56-734-001-LI
1-842908-0	56-734-005-LI
1-842908-1	56-734-007-LI
1-842908-2	56-734-007-LI
1-842908-4	56-734-XXX-LI**
1-842909-3	56-744-001-LI
1-842909-0	56-744-005-LI
1-842909-1	56-744-007-LI
1-842909-2	56-744-007-LI
1-842909-4	56-744-XXX-LI**
1-842910-3	56-701-001-LI
1-842910-0	56-701-005-LI
1-842910-1	56-701-029-LI
1-842910-2	56-701-029-LI
1-842910-4	56-701-XXX-LI**

AMP Part Number	Spectrum Part Number
1-842911-3	56-711-001-LI
1-842911-0	56-711-005-LI
1-842911-1	56-711-029-LI
1-842911-2	56-711-029-LI
1-842911-4	56-711-XXX-LI**
1-842912-3	56-721-001-LI
1-842912-0	56-721-005-LI
1-842912-1	56-721-034-LI
1-842912-2	56-721-034-LI
1-842912-4	56-721-XXX-LI**
1-842913-3	56-731-001-LI
1-842913-0	56-731-005-LI
1-842913-1	56-731-029-LI
1-842913-2	56-731-029-LI
1-842913-4	56-731-XXX-LI**
1-842914-3	56-741-001-LI
1-842914-0	56-741-005-LI
1-842914-1	56-741-028-LI
1-842914-2	56-741-028-LI
1-842914-4	56-741-XXX-LI**
1-842915-3	56-703-001-LI
1-842915-0	56-703-005-LI
1-842915-1	56-703-023-LI
1-842915-2	56-703-023-LI
1-842915-4	56-703-XXX-LI**
1-842916-3	56-713-001-LI
1-842916-0	56-713-005-LI
1-842916-1	56-713-022-LI
1-842916-2	56-713-022-LI
1-842916-4	56-713-XXX-LI**
1-842917-3	56-723-001-LI
1-842917-0	56-723-005-LI
1-842917-1	56-723-024-LI
1-842917-2	56-723-024-LI
1-842917-4	56-723-XXX-LI**
1-842918-3	56-733-001-LI
1-842918-0	56-733-005-LI
1-842918-1	56-733-022-LI
1-842918-2	56-733-022-LI
1-842918-4	56-733-XXX-LI**
1-842919-3	56-743-001-LI
1-842919-0	56-743-005-LI
1-842919-1	56-743-022-LI
1-842919-2	56-743-022-LI
1-842919-4	56-743-XXX-LI**
1-842920-3	56-701-011-LI
1-842920-0	56-701-015-LI
1-842920-1	56-701-041-LI
1-842920-2	56-701-041-LI
1-842920-4	56-701-XXX-LI**
1-842921-3	56-711-011-LI
1-842921-0	56-711-015-LI
1-842921-1	56-711-041-LI
1-842921-2	56-711-041-LI
1-842921-4	56-711-XXX-LI**
1-842922-3	56-721-011-LI
1-842922-0	56-721-015-LI
1-842922-1	56-721-046-LI
1-842922-2	56-721-046-LI
1-842922-4	56-721-XXX-LI**
1-842923-3	56-731-011-LI

AMP Part Number	Spectrum Part Number
1-842923-0	56-731-015-LI
1-842923-1	56-731-041-LI
1-842923-2	56-731-041-LI
1-842923-4	56-731-XXX-LI**
1-842924-3	56-741-011-LI
1-842924-0	56-741-015-LI
1-842924-1	56-741-040-LI
1-842924-2	56-741-040-LI
1-842924-4	56-741-XXX-LI**
1-842925-3	56-706-001-LI
1-842925-0	56-706-005-LI
1-842925-1	56-706-007-LI
1-842925-2	56-706-007-LI
1-842925-8	56-706-XXX**
1-842925-4	56-706-XXX-LI**
1-842926-3	56-716-001-LI
1-842926-0	56-716-005-LI
1-842926-1	56-716-007-LI
1-842926-2	56-716-007-LI
1-842926-4	56-716-XXX-LI**
1-842927-3	56-726-001-LI
1-842927-0	56-726-005-LI
1-842927-1	56-726-007-LI
1-842927-2	56-726-007-LI
1-842927-4	56-726-XXX-LI**
1-842928-3	56-736-001-LI
1-842928-0	56-736-005-LI
1-842928-1	56-736-007-LI
1-842928-2	56-736-007-LI
1-842928-6	56-736-XXX**
1-842928-7	56-736-XXX**
1-842928-4	56-736-XXX-LI**
1-842929-3	56-746-001-LI
1-842929-0	56-746-005-LI
1-842929-1	56-746-007-LI
1-842929-2	56-746-007-LI
1-842929-4	56-746-XXX-LI**
1-842930-3	56-705-001-LI
1-842930-0	56-705-005-LI
1-842930-1	56-705-009-LI
1-842930-2	56-705-009-LI
1-842930-4	56-705-XXX-LI**
1-842931-3	56-715-001-LI
1-842931-0	56-715-005-LI
1-842931-1	56-715-008-LI
1-842931-2	56-715-008-LI
1-842931-4	56-715-XXX-LI**
1-842932-3	56-725-001-LI
1-842932-0	56-725-005-LI
1-842932-1	56-725-020-LI
1-842932-2	56-725-020-LI
1-842932-4	56-725-XXX-LI**
1-842933-3	56-735-001-LI
1-842933-0	56-735-005-LI
1-842933-1	56-735-009-LI
1-842933-2	56-735-009-LI
1-842933-4	56-735-XXX-LI**
1-842934-3	56-745-001-LI
1-842934-0	56-745-005-LI
1-842934-1	56-745-007-LI
1-842934-2	56-745-007-LI

\* There may be mechanical and/or electrical differences between the Amp and Spectrum part. Please consult factory.

\*\* A standard part number does not currently exist but will be assigned upon ordering.

# Spectrum Control/AMP Part Number Cross Reference

AMP Part Number	Spectrum Part Number
1-842934-4	56-745-XXX-LI**
1-869464-0	56-124-002
1-869470-0	56-102-002
1-869476-0	56-122-002
1-869522-0	56-104-002
1-869523-0	56-114-002
1-869527-0	56-112-002
1-93768-0	56-701-081-LI
1-93769-0	56-711-085-LI
1-93770-0	56-721-070-LI
1-93771-0	56-731-060-LI
1-93772-0	56-706-009-LI
1-93773-0	56-716-009-LI
1-93774-0	56-726-009-LI
1-93775-0	56-736-009-LI
267100-1	56-C31-001
267116-1	56-407-001
267161-2	56-423-001
267290-1	56-724-008-GBL
267292-1	56-624-XXX**
267397-1	56-413-001
267809-1	56-703-022
267810-1	56-713-021
267811-1	56-723-022
267824-1	56-102-006
267824-2	56-102-005
267824-3	56-102-004
267824-4	56-102-003
267824-5	56-102-002
267825-1	56-112-006
267825-2	56-112-005
267825-3	56-112-004
267825-4	56-112-003
267825-5	56-112-002
267826-1	56-122-006
267826-2	56-122-005
267826-3	56-122-004
267826-4	56-122-003
267826-5	56-122-002
267827-1	56-104-006
267827-2	56-104-005
267827-3	56-104-004
267827-4	56-104-003
267827-5	56-104-002
267828-1	56-114-006
267828-2	56-114-005
267828-3	56-114-004
267828-4	56-114-003
267828-5	56-114-002
267829-1	56-124-006
267829-2	56-124-005
267829-3	56-124-004
267829-4	56-124-003
267829-5	56-124-002
267980-1	56-102-006
267980-2	56-102-005
267980-3	56-102-004
267980-4	56-102-003
267980-5	56-102-002
267981-1	56-112-006
267981-2	56-112-005

AMP Part Number	Spectrum Part Number
267981-3	56-112-004
267981-4	56-112-003
267981-5	56-112-002
267982-1	56-122-006
267982-2	56-122-005
267982-3	56-122-004
267982-4	56-122-003
267982-5	56-122-002
267983-1	56-104-006
267983-2	56-104-005
267983-3	56-104-004
267983-4	56-104-003
267983-5	56-104-002
267984-1	56-114-006
267984-2	56-114-005
267984-3	56-114-004
267984-4	56-114-003
267984-5	56-114-002
267985-1	56-124-006
267985-2	56-124-005
267985-3	56-124-004
267985-4	56-124-003
267985-5	56-124-002
2-842919-6	56-743-003-LI
2-842920-2	56-701-042
2-842927-2	56-726-XXX**
3-842917-1	56-723-045-LI
3-842917-2	56-723-XXX**
3-842917-3	56-723-XXX**
842582-3	56-701-047
842582-4	56-701-047-LI
842583-3	56-711-048
842583-4	56-711-048-LI
842584-3	56-721-063
842584-4	56-721-063-LI
842585-3	56-731-048
842585-4	56-731-048-LI
842586-3	56-703-036
842586-4	56-703-036-LI
842587-3	56-713-037
842587-4	56-713-037-LI
842588-3	56-723-045
842588-4	56-723-045-LI
842589-3	56-733-035
842589-4	56-733-035-LI
842590-3	56-702-013
842590-4	56-702-013-LI
842591-3	56-712-017
842591-4	56-712-017-LI
842592-3	56-722-027
842592-4	56-722-027-LI
842593-3	56-732-009
842593-4	56-732-009-LI
842594-3	56-704-018
842594-4	56-704-018-LI
842595-3	56-714-017
842595-4	56-714-017-LI
842596-3	56-724-021
842596-4	56-724-021-LI
842597-3	56-734-012
842597-4	56-734-012-LI

AMP Part Number	Spectrum Part Number
842610-3	56-701-086
842610-4	56-701-086-LI
842611-3	56-711-088
842611-4	56-711-088-LI
842612-3	56-721-111
842612-4	56-721-111-LI
842613-3	56-731-076
842613-4	56-731-076-LI
842614-3	56-703-047
842614-4	56-703-047-LI
842615-3	56-713-045
842615-4	56-713-045-LI
842616-3	56-723-069
842616-4	56-723-069-LI
842617-3	56-733-046
842617-4	56-733-046-LI
842618-3	56-702-033
842618-4	56-702-033-LI
842619-3	56-712-039
842619-4	56-712-039-LI
842620-3	56-722-060
842620-4	56-722-060-LI
842621-3	56-732-023-LI
842621-4	56-732-023-LI
842622-3	56-704-035
842622-4	56-704-035-LI
842623-3	56-714-031
842623-4	56-714-031-LI
842624-3	56-724-046
842624-4	56-724-046-LI
842625-3	56-734-021
842625-4	56-734-021-LI
842638-3	56-701-028
842638-4	56-701-028-LI
842639-3	56-711-028
842639-4	56-711-028-LI
842640-3	56-721-033
842640-4	56-721-033-LI
842641-3	56-731-028
842641-4	56-731-028-LI
842642-3	56-703-022
842642-4	56-703-022-LI
842643-3	56-713-021
842643-4	56-713-021-LI
842644-3	56-723-023
842644-4	56-723-023-LI
842645-3	56-733-021
842645-4	56-733-021-LI
842646-3	56-702-007
842646-4	56-702-007-LI
842647-3	56-712-007
842647-4	56-712-007-LI
842648-3	56-722-008
842648-4	56-722-008-LI
842649-3	56-732-006
842649-4	56-732-006-LI
842650-3	56-704-007
842650-4	56-704-007-LI
842651-3	56-714-006
842651-4	56-714-006-LI
842652-3	56-724-008

\* There may be mechanical and/or electrical differences between the Amp and Spectrum part. Please consult factory.

\*\* A standard part number does not currently exist but will be assigned upon ordering.

# Spectrum Control/AMP Part Number Cross Reference

AMP Part Number	Spectrum Part Number
842652-4	56-724-008-LI
842653-3	56-734-006
842653-4	56-734-006-LI
842666-3	56-701-002
842666-4	56-701-002-LI
842667-3	56-711-002
842667-4	56-711-002-LI
842668-3	56-721-002
842668-4	56-721-002-LI
842669-3	56-731-002
842669-4	56-731-002-LI
842670-3	56-703-002
842670-4	56-703-002-LI
842671-3	56-713-002
842671-4	56-713-002-LI
842672-3	56-723-002
842672-4	56-723-002-LI
842673-3	56-733-002
842673-4	56-733-002-LI
842674-3	56-702-002
842674-4	56-702-002-LI
842675-3	56-712-002
842675-4	56-712-002-LI
842675-5	56-712-002-LIM
842676-3	56-722-002
842676-4	56-722-002-LI
842677-3	56-732-002
842677-4	56-732-002-LI
842678-3	56-704-002
842678-4	56-704-002-LI
842679-3	56-714-002
842679-4	56-714-002-LI
842680-3	56-724-002
842680-4	56-724-002-LI
842681-3	56-734-002
842681-4	56-734-002-LI
842697-3	56-705-008
842697-4	56-705-008-LI
842697-5	56-705-026-LI
842697-5	56-705-XXX**
842698-3	56-715-007
842698-4	56-715-007-LI
842699-3	56-725-019
842699-4	56-725-019-LI
842700-3	56-735-008
842700-4	56-735-008-LI
842737-3	56-705-002
842737-4	56-705-002-LI
842738-3	56-705-026
842738-4	56-705-026-LI
842738-5	56-705-026-HV
842739-3	56-705-049
842739-4	56-705-049-LI
842740-3	56-715-002
842740-4	56-715-002-LI
842741-3	56-715-015
842741-4	56-715-015-LI
842742-3	56-715-040
842742-4	56-715-040-LI
842743-3	56-725-002

AMP Part Number	Spectrum Part Number
842743-4	56-725-002-LI
842744-3	56-725-064
842744-4	56-725-064-LI
842744-5	56-725-XXX**
842745-3	56-725-073
842745-4	56-725-073-LI
842746-3	56-735-002
842746-4	56-735-002-LI
842747-3	56-735-025
842747-4	56-735-025-LI
842748-3	56-735-034
842748-4	56-735-034-LI
842796-2	56-725-064-HV
842797-2	56-735-025-HV
842830-3	56-706-006
842900-1	56-702-003
842900-2	56-702-009
842900-3	56-702-005
842900-4	56-702-008
842900-5	56-702-008
842900-6	56-702-001
842900-7	56-702-XXX**
842900-8	56-702-003-LI
842900-9	56-702-009-LI
842901-1	56-712-003
842901-2	56-712-009
842901-3	56-712-005
842901-4	56-712-008
842901-5	56-712-008
842901-6	56-712-001
842901-7	56-712-XXX**
842901-8	56-712-003-LI
842901-9	56-712-009-LI
842902-1	56-722-003
842902-2	56-722-010
842902-3	56-722-005
842902-4	56-722-009
842902-5	56-722-009
842902-6	56-722-001
842902-7	56-722-XXX**
842902-8	56-722-003-LI
842902-9	56-722-010-LI
842903-1	56-732-003
842903-2	56-732-008
842903-3	56-732-005
842903-4	56-732-007
842903-5	56-732-007
842903-6	56-732-001
842903-7	56-732-XXX**
842903-8	56-732-003-LI
842903-9	56-732-008-LI
842904-1	56-742-003
842904-2	56-742-008
842904-3	56-742-005
842904-4	56-742-007
842904-5	56-742-007
842904-6	56-742-001
842904-7	56-742-XXX**
842904-8	56-742-003-LI
842904-9	56-742-008-LI
842905-1	56-704-003

AMP Part Number	Spectrum Part Number
842905-2	56-704-009
842905-3	56-704-005
842905-4	56-704-008
842905-5	56-704-008
842905-6	56-704-001
842905-7	56-704-XXX**
842905-8	56-704-003-LI
842905-9	56-704-009-LI
842906-1	56-714-003
842906-2	56-714-008
842906-3	56-714-005
842906-4	56-714-007
842906-5	56-714-007
842906-6	56-714-001
842906-7	56-714-XXX**
842906-8	56-714-003-LI
842906-9	56-714-008-LI
842907-1	56-724-003
842907-2	56-724-010
842907-3	56-724-005
842907-4	56-724-009
842907-5	56-724-009
842907-6	56-724-001
842907-7	56-724-XXX**
842907-8	56-724-003-LI
842907-9	56-724-010-LI
842908-1	56-734-003
842908-2	56-734-008
842908-3	56-734-005
842908-4	56-734-007
842908-5	56-734-007
842908-6	56-734-001
842908-7	56-734-XXX**
842908-8	56-734-003-LI
842908-9	56-734-008-LI
842909-1	56-744-003
842909-2	56-744-008
842909-3	56-744-005
842909-4	56-744-007
842909-5	56-744-007
842909-6	56-744-001
842909-7	56-744-XXX**
842909-8	56-744-003-LI
842909-9	56-744-008-LI
842910-1	56-701-003
842910-2	56-701-030
842910-3	56-701-005
842910-4	56-701-029
842910-5	56-701-029
842910-6	56-701-001
842910-7	56-701-XXX**
842910-8	56-701-003-LI
842910-9	56-701-030-LI
842911-1	56-711-003
842911-2	56-711-030
842911-3	56-711-005
842911-4	56-711-029
842911-5	56-711-029
842911-6	56-711-001
842911-7	56-711-XXX**
842911-8	56-711-003-LI

\* There may be mechanical and/or electrical differences between the Amp and Spectrum part. Please consult factory.

\*\* A standard part number does not currently exist but will be assigned upon ordering.

# Spectrum Control/AMP Part Number Cross Reference

AMP Part Number	Spectrum Part Number
842911-9	56-711-030-LI
842912-1	56-721-003
842912-2	56-721-035
842912-3	56-721-005
842912-4	56-721-034
842912-5	56-721-034
842912-6	56-721-001
842912-7	56-721-XXX**
842912-8	56-721-003-LI
842912-9	56-721-035-LI
842913-1	56-731-003
842913-2	56-731-030
842913-3	56-731-005
842913-4	56-731-029
842913-5	56-731-029
842913-6	56-731-001
842913-7	56-731-XXX**
842913-8	56-731-003-LI
842913-9	56-731-030-LI
842914-1	56-741-003
842914-2	56-741-029
842914-3	56-741-005
842914-4	56-741-028
842914-5	56-741-028
842914-6	56-741-001
842914-7	56-741-XXX**
842914-8	56-741-003-LI
842914-9	56-741-029-LI
842915-1	56-703-003
842915-2	56-703-024
842915-3	56-703-005
842915-4	56-703-023
842915-5	56-703-023
842915-6	56-703-001
842915-7	56-703-XXX**
842915-8	56-703-003-LI
842915-9	56-703-024-LI
842916-1	56-713-003
842916-2	56-713-023
842916-3	56-713-005
842916-4	56-713-022
842916-5	56-713-022
842916-6	56-713-001
842916-7	56-713-XXX**
842916-8	56-713-003-LI
842916-9	56-713-023-LI
842917-1	56-723-003
842917-2	56-723-025
842917-3	56-723-005
842917-4	56-723-024
842917-5	56-723-024
842917-6	56-723-001
842917-7	56-723-XXX**
842917-8	56-723-003-LI
842917-9	56-723-025-LI
842918-1	56-733-003
842918-2	56-733-023
842918-3	56-733-005
842918-4	56-733-022
842918-5	56-733-022
842918-6	56-733-001

AMP Part Number	Spectrum Part Number
842918-7	56-733-XXX**
842918-8	56-733-003-LI
842918-9	56-733-023-LI
842919-1	56-743-003
842919-2	56-743-023
842919-3	56-743-005
842919-4	56-743-022
842919-5	56-743-022
842919-6	56-743-001
842919-7	56-743-XXX**
842919-8	56-743-003-LI
842919-9	56-743-023-LI
842920-1	56-701-013
842920-2	56-701-042
842920-3	56-701-015
842920-4	56-701-041
842920-5	56-701-041
842920-6	56-701-011
842920-7	56-701-XXX**
842920-8	56-701-013-LI
842920-9	56-701-042-LI
842921-1	56-711-013
842921-2	56-711-042
842921-3	56-711-015
842921-4	56-711-041
842921-5	56-711-041
842921-6	56-711-011
842921-7	56-711-XXX**
842921-8	56-711-013-LI
842921-9	56-711-042-LI
842922-1	56-721-013
842922-2	56-721-047
842922-3	56-721-015
842922-4	56-721-046
842922-5	56-721-046
842922-6	56-721-011
842922-7	56-721-XXX**
842922-8	56-721-013-LI
842922-9	56-721-047-LI
842923-1	56-731-013
842923-2	56-731-042
842923-3	56-731-015
842923-4	56-731-041
842923-5	56-731-041
842923-6	56-731-011
842923-7	56-731-XXX**
842923-8	56-731-013-LI
842923-9	56-731-042-LI
842924-1	56-741-013
842924-2	56-741-041
842924-3	56-741-015
842924-4	56-741-040
842924-5	56-741-040
842924-6	56-741-011
842924-7	56-741-XXX**
842924-8	56-741-013-LI
842924-9	56-741-041-LI
842925-1	56-706-003
842925-2	56-706-008
842925-3	56-706-005
842925-4	56-706-007

AMP Part Number	Spectrum Part Number
842925-5	56-706-007
842925-6	56-706-001
842925-7	56-706-XXX**
842925-8	56-706-003-LI
842925-9	56-706-005-LI
842926-1	56-716-003
842926-2	56-716-008
842926-3	56-716-005
842926-4	56-716-007
842926-5	56-716-007
842926-6	56-716-001
842926-7	56-716-XXX**
842926-8	56-716-003-LI
842926-9	56-716-008-LI
842927-1	56-726-003
842927-2	56-726-008
842927-3	56-726-005
842927-4	56-726-007
842927-5	56-726-007
842927-6	56-726-001
842927-7	56-726-XXX**
842927-8	56-726-003-LI
842927-9	56-726-008-LI
842928-1	56-736-003
842928-2	56-736-008
842928-3	56-736-005
842928-4	56-736-007
842928-5	56-736-007
842928-6	56-736-001
842928-7	56-736-XXX**
842928-8	56-736-003-LI
842928-9	56-736-008-LI
842929-1	56-746-003
842929-2	56-746-008
842929-3	56-746-005
842929-4	56-746-007
842929-5	56-746-007
842929-6	56-746-001
842929-7	56-746-XXX**
842929-8	56-746-003-LI
842929-9	56-746-008-LI
842930-1	56-705-003
842930-2	56-705-010
842930-3	56-705-005
842930-4	56-705-009
842930-5	56-705-009
842930-6	56-705-001
842930-7	56-705-XXX**
842930-8	56-705-003-LI
842930-9	56-705-010-LI
842931-1	56-715-003
842931-2	56-715-009
842931-3	56-715-005
842931-4	56-715-008
842931-5	56-715-008
842931-6	56-715-001
842931-7	56-715-XXX**
842931-8	56-715-003-LI
842931-9	56-715-009-LI
842932-1	56-725-003
842932-2	56-725-021

\* There may be mechanical and/or electrical differences between the Amp and Spectrum part. Please consult factory.

\*\* A standard part number does not currently exist but will be assigned upon ordering.

# Spectrum Control/AMP Part Number Cross Reference

AMP Part Number	Spectrum Part Number
842932-3	56-725-005
842932-4	56-725-020
842932-5	56-725-020
842932-6	56-725-001
842932-7	56-725-XXX**
842932-8	56-725-003-LI
842932-9	56-725-021-LI
842933-1	56-735-003
842933-2	56-735-010
842933-3	56-735-005
842933-4	56-735-009
842933-5	56-735-009
842933-6	56-735-001
842933-7	56-735-XXX**
842933-8	56-735-003-LI
842933-9	56-735-010-LI
842934-1	56-745-003
842934-2	56-745-008
842934-3	56-745-005
842934-4	56-745-007
842934-5	56-745-007
842934-6	56-745-001
842934-7	56-745-XXX**
842934-8	56-745-003-LI
842934-9	56-745-008-LI
842938-1	56-701-004
842938-2	56-701-004-LI
842939-1	56-711-004
842939-2	56-711-004-LI
842940-1	56-721-004
842940-2	56-721-004-LI
842941-1	56-731-004
842941-2	56-731-004-LI
842942-1	56-703-004
842942-2	56-703-004-LI
842943-1	56-713-004
842943-2	56-713-004-LI
842944-1	56-723-004
842944-2	56-723-004-LI
842945-1	56-733-004
842945-2	56-733-004-LI
842946-1	56-702-004
842946-2	56-702-004-LI
842947-1	56-712-004
842947-2	56-712-004-LI
842948-1	56-722-004
842948-2	56-722-004-LI
842949-1	56-732-004
842949-2	56-732-004-LI
842950-1	56-704-004
842950-2	56-704-004-LI
842951-1	56-714-004
842951-2	56-714-004-LI
842952-1	56-724-004
842952-2	56-724-004-LI
842953-1	56-734-004
842953-2	56-734-004-LI
842954-1	56-705-004
842954-2	56-705-004-LI
842955-1	56-715-004
842955-2	56-715-004-LI

AMP Part Number	Spectrum Part Number
842956-1	56-725-004
842956-2	56-725-004-LI
842956-3	56-725-004-LI
842957-1	56-735-004
842957-2	56-735-004-LI
842957-3	56-735-004-LI
859762-1	56-726-003
869202-1	56-715-004
869214-1	56-701-003-LIM
869248-1	56-711-003-LIM
869408-1	56-715-XXX**
869427-2	56-414-001-HD
869436-2	56-402-001
869442-2	56-422-001
869454-1	56-704-007-LI
869464-5	56-124-006
869464-6	56-124-005
869464-7	56-124-004
869464-8	56-124-003
869470-5	56-102-006
869470-6	56-102-005
869470-7	56-102-004
869470-8	56-102-003
869476-5	56-122-006
869476-6	56-122-005
869476-7	56-122-004
869476-8	56-122-003
869520-2	56-404-001
869521-2	56-424-001
869522-5	56-104-006
869522-6	56-104-005
869522-7	56-104-004
869522-8	56-104-003
869523-5	56-114-006
869523-6	56-114-005
869523-7	56-114-004
869523-8	56-114-003
869526-2	56-412-001
869527-5	56-112-006
869527-6	56-112-005
869527-7	56-112-004
869527-8	56-112-003
93544-3	56-C31-201-SOX
93725-1	56-C33-001
93768-1	56-701-014
93768-2	56-701-012
93768-3	56-701-040
93768-4	56-701-087
93768-5	56-701-081
93768-6	56-701-014-LI
93768-7	56-701-012-LI
93768-8	56-701-040-LI
93768-9	56-701-087-LI
93769-1	56-711-014
93769-2	56-711-012
93769-3	56-711-040
93769-4	56-711-086
93769-5	56-711-085
93769-6	56-711-014-LI
93769-7	56-711-012-LI
93769-8	56-711-040-LI

AMP Part Number	Spectrum Part Number
93769-9	56-711-086-LI
93770-1	56-721-014
93770-2	56-721-012
93770-3	56-721-045
93770-4	56-721-112
93770-5	56-721-070
93770-6	56-721-014-LI
93770-7	56-721-012-LI
93770-8	56-721-045-LI
93770-9	56-721-112-LI
93771-1	56-731-014
93771-2	56-731-012
93771-3	56-731-040-LI
93771-4	56-731-077
93771-5	56-731-060
93771-6	56-731-014-LI
93771-7	56-731-012-LI
93771-8	56-731-040-LI
93771-9	56-731-077-LI
93772-1	56-706-004
93772-2	56-706-002
93772-3	56-706-006
93772-4	56-706-017
93772-5	56-706-009
93772-6	56-706-004-LI
93772-7	56-706-002-LI
93772-8	56-706-006-LI
93772-9	56-706-017-LI
93773-1	56-716-004
93773-2	56-716-002
93773-3	56-716-006
93773-4	56-716-013
93773-5	56-716-009
93773-6	56-716-004-LI
93773-7	56-716-002-LI
93773-8	56-716-006-LI
93773-9	56-716-013-LI
93774-1	56-726-004
93774-2	56-726-002
93774-3	56-726-006
93774-4	56-726-021
93774-5	56-726-009
93774-6	56-726-004-LI
93774-7	56-726-002-LI
93774-8	56-726-006-LI
93774-9	56-726-021-LI
93775-1	56-736-004
93775-2	56-736-002
93775-3	56-736-006
93775-4	56-736-015
93775-5	56-736-009
93775-6	56-736-004-LI
93775-7	56-736-002-LI
93775-8	56-736-006-LI
93775-9	56-736-015-LI

\* There may be mechanical and/or electrical differences between the Amp and Spectrum part. Please consult factory.

\*\* A standard part number does not currently exist but will be assigned upon ordering.

# Part Number Index

Spectrum part #	Page	Spectrum part #	Page	Spectrum part #	Page	Spectrum part #	Page
1201-052.....	80	51-321-312.....	98	51-359-051.....	87	51-712-055.....	76
1201-054.....	80	51-321-313.....	98	51-359-053.....	87	51-712-060.....	76
1201-066.....	80	51-321-314.....	98	51-359-055.....	87	51-712-063.....	76
1201-086.....	80	51-321-317.....	98	51-359-081.....	87	51-712-065.....	76
1202-005.....	81	51-321-318.....	98	51-359-082.....	87	51-712-067.....	76
1202-052.....	81	51-321-319.....	98	51-359-083.....	87	51-712-069.....	76
1202-054.....	81	51-321-322.....	98	51-359-084.....	87	51-713-002.....	67
1203-050.....	67	51-321-329.....	98	51-359-085.....	87	51-713-010.....	67
1204-050.....	67	51-321-398.....	98	51-359-086.....	87	51-714-001.....	80
1214-001.....	67	51-321-399.....	98	51-359-088.....	87	51-714-002.....	80
1214-007.....	67	51-321-400.....	98	51-359-090.....	87	51-714-003.....	80
1214-029.....	67	51-321-401.....	98	51-359-105.....	87	51-714-004.....	80
1216-001.....	80	51-321-607.....	99	51-382-603.....	93	51-714-051.....	80
1221-001.....	80	51-321-608.....	99	51-382-609.....	93	51-714-052.....	80
1223-012.....	67	51-321-610.....	99	51-390-018.....	89	51-714-053.....	80
1233-000.....	67	51-321-649.....	99	51-390-026.....	89	51-714-054.....	80
1234-000.....	67	51-321-670.....	99	51-390-034.....	89	51-714-055.....	80
1234-001.....	67	51-322-007.....	96	51-390-039.....	90	51-714-056.....	80
1250-003.....	76	51-322-009.....	97	51-390-040.....	90	51-714-058.....	80
1250-049.....	76	51-322-015.....	96	51-390-305.....	92	51-717-001.....	86
1250-054.....	76	51-322-017.....	97	51-390-311.....	92	51-717-007.....	87
1250-059.....	76	51-322-036.....	96	51-390-312.....	92	51-719-011.....	80
1250-062.....	76	51-323-003.....	97	51-390-314.....	92	51-719-021.....	80
1251-001.....	67	51-323-004.....	97	51-390-315.....	92	51-719-022.....	80
1270-009.....	80	51-323-313.....	98	51-390-317.....	92	51-719-023.....	80
1270-016.....	80	51-343-028.....	89	51-390-318.....	92	51-719-053.....	80
1270-024.....	80	51-343-034.....	89	51-444-005.....	90	51-719-054.....	80
1270-025.....	80	51-344-006.....	86	51-444-027.....	90	51-723-301.....	67
1280-060.....	83	51-351-603.....	93	51-444-039.....	89	51-723-303.....	67
1289-001.....	74	51-351-604.....	93	51-444-040.....	90	51-726-001.....	74
1289-004.....	74	51-351-605.....	93	51-444-043.....	90	51-726-002.....	74
1293-000.....	76	51-353-003.....	88	51-444-044.....	90	51-726-008.....	74
1293-001.....	76	51-353-007.....	88	51-444-046.....	90	51-726-017.....	74
2560-9000-01.....	193	51-353-053.....	89	51-444-047.....	90	51-729-303.....	73
2560-9000-02.....	193	51-353-054.....	89	51-444-060.....	89	51-729-304.....	73
2560-9000-03.....	193	51-353-055.....	89	51-444-072.....	89	51-729-305.....	73
2560-9000-04.....	193	51-353-066.....	89	51-444-117.....	90	51-729-312.....	73
2560-9001-01.....	193	51-353-067.....	89	51-570-300.....	92	51-744-002.....	76
2560-9001-02.....	193	51-353-076.....	90	51-570-301.....	92	51-744-003.....	76
2560-9001-03.....	193	51-353-077.....	90	51-570-302.....	92	51-750-301.....	67
2560-9001-04.....	193	51-353-078.....	90	51-570-303.....	92	51-750-302.....	67
51-311-308.....	92	51-353-079.....	90	51-570-304.....	92	51-750-309.....	67
51-311-309.....	92	51-353-080.....	90	51-570-310.....	92	51-750-313.....	67
51-311-310.....	92	51-353-081.....	90	51-570-311.....	92	51-750-322.....	67
51-311-311.....	92	51-353-095.....	88	51-570-312.....	92	51-761-001.....	77
51-311-312.....	92	51-353-099.....	88	51-570-313.....	92	51-761-002.....	77
51-311-314.....	92	51-353-100.....	88	51-570-314.....	92	51-762-005.....	76
51-311-316.....	91	51-353-101.....	89	51-570-320.....	92	51-762-006.....	76
51-311-317.....	91	51-353-109.....	89	51-570-321.....	92	52-160-002-A.....	121
51-311-319.....	91	51-353-110.....	89	51-570-322.....	92	52-160-003-A.....	121
51-311-320.....	91	51-353-111.....	89	51-570-323.....	92	52-160-004-A.....	121
51-311-321.....	91	51-353-112.....	89	51-570-324.....	92	52-160-005-A.....	121
51-311-322.....	91	51-353-113.....	89	51-702-020.....	81	52-160-006-A.....	121
51-311-408.....	92	51-353-114.....	89	51-702-021.....	81	52-188-002-A.....	121
51-320-015.....	97	51-353-116.....	89	51-703-001.....	67	52-188-003-A.....	121
51-320-017.....	97	51-353-120.....	89	51-703-007.....	67	52-188-004-A.....	121
51-320-018.....	97	51-353-155.....	89	51-703-012.....	67	52-188-005-A.....	121
51-320-024.....	96	51-353-156.....	90	51-703-013.....	67	52-188-006-A.....	121
51-320-026.....	96	51-353-157.....	90	51-704-002.....	67	52-227-002.....	123
51-320-041.....	96	51-353-207.....	89	51-707-002.....	67	52-227-003.....	123
51-320-100.....	96	51-353-287.....	89	51-707-006.....	67	52-227-004.....	123
51-320-103.....	96	51-353-336.....	92	51-707-007.....	67	52-227-005.....	123
51-320-162.....	97	51-353-344.....	92	51-707-026.....	67	52-227-006.....	123
51-320-163.....	97	51-353-345.....	92	51-709-004.....	80	52-227-007.....	123
51-320-164.....	97	51-359-001.....	86	51-709-013.....	80	52-227-008.....	123
51-320-165.....	97	51-359-007.....	87	51-709-015.....	80	52-227-009.....	123
51-320-166.....	97	51-359-021.....	87	51-712-001.....	76	52-227-010.....	123
51-320-167.....	97	51-359-024.....	87	51-712-003.....	76	52-227-011.....	123
51-320-168.....	97	51-359-044.....	87	51-712-014.....	76	52-227-012.....	123
51-320-169.....	97	51-359-050.....	87	51-712-028.....	76	52-228-002.....	123

# Part Number Index

Spectrum part #	Page	Spectrum part #	Page	Spectrum part #	Page	Spectrum part #	Page
52-228-003	123	54-844-002	83	56-202-003	191	56-702-002	148
52-228-004	123	54-848-005	83	56-202-004	191	56-702-003	148
52-228-005	123	54-848-008	83	56-202-005	191	56-702-004	148
52-228-006	123	54-853-001	83	563XXXXXXXXXXXXX	170	56-702-005	148
52-228-007	123	54-853-004	83	56-402-001	130	56-702-007	148
52-228-008	123	54-862-001	72	56-403-001	133	56-702-008	148
52-228-009	123	54-862-002	72	56-404-001	131	56-702-009	148
52-228-010	123	54-862-003	72	56-407-001	132	56-702-013	148
52-228-011	123	54-874-010	38	56-412-001	130	56-702-033	148
52-228-012	123	54-874-011	70	56-413-001	133	56-703-001	150
52-898-XXX-XXX	104	54-874-012	70	56-414-001	131	56-703-002	150
52-960-XXX-XXX	104	54-874-013	70	56-414-001-HD	131	56-703-003	150
52-970-XXX-XXX	110	54-874-014	70	56-417-001	132	56-703-004	150
52-971-XXX-XXX	110	54-874-015	70	56-422-001	130	56-703-005	150
52-978-XXX-XXX	108	54-874-016	70	45-423-001	133	56-703-006	151
52-979-XXX-XXX	108	54-874-017	70	56-424-001	131	56-703-007	151
53-038-XXX-XXX	114	54-874-018	70	56-427-001	132	56-703-008	151
54-310-001	95	54713001X5F101M	75	56-5XX-XXX-XXX	141	56-703-009	151
54-310-005	95	54713001X5U102P	75	56-6XX-XXX-XX	142	56-703-010	151
54-310-009	95	54743001X5U102Z	78	56-645-002	145	56-703-011	151
54-310-039	95	54779001X5F100M	74	56-700-002	190	56-703-012	151
54-310-042	95	54779001X5U102P	74	56-700-002-JS	190	56-703-013	151
54-367-005	85	54790001X5F101M	72	56-701-001	148	56-703-014	151
54-367-006	85	54794002X5R101M	65	56-701-002	148	56-703-015	151
54-367-007	85	54794002X5R471M	65	56-701-003	148	56-703-016	151
54-367-008	85	54794002X5V102P	65	56-701-004	148	56-703-017	151
54-367-049	85	54802002X5R101M	65	56-701-005	148	56-703-018	151
54-367-051	85	54802002X5R471M	65	56-701-006	149	56-703-019	151
54-367-053	85	54802002X5V102P	65	56-701-007	149	56-703-020	151
54-367-054	85	54803004X5R101M	65	56-701-008	149	56-703-022	150
54-367-055	85	54803004X5R471M	65	56-701-009	149	56-703-023	150
54-367-056	85	54803004X5V102P	65	56-701-010	149	56-703-024	150
54-367-057	85	54804002X5R101M	78	56-701-011	149	56-703-025	151
54-367-058	85	54804002X5R471M	78	56-701-012	149	56-703-026	151
54-370-006	85	54804002X5V102P	78	56-701-013	149	56-703-027	151
54-370-007	85	56-102-002	135	56-701-014	149	56-703-028	151
54-370-030	85	56-102-003	135	56-701-015	149	56-703-029	151
54-370-032	85	56-102-004	135	56-701-017	149	56-703-030	151
54-370-033	85	56-102-005	135	56-701-018	149	56-703-031	151
54-370-034	85	56-102-006	135	56-701-019	149	56-703-032	151
54-371-001	85	56-104-002	135	56-701-020	149	56-703-033	151
54-763-008	83	56-104-003	135	56-701-021	149	56-703-036	150
54-763-009	83	56-104-004	135	56-701-022	149	56-703-037	151
54-779-014	74	56-104-005	135	56-701-023	149	56-703-038	151
54-779-015	74	56-104-006	135	56-701-024	149	56-703-039	151
54-779-016	74	56-112-002	135	56-701-025	149	56-703-047	150
54-779-017	74	56-112-003	135	56-701-026	149	56-704-001	150
54-779-018	74	56-112-004	135	56-701-028	148	56-704-002	150
54-779-019	74	56-112-005	135	56-701-029	148	56-704-003	150
54-785-002	65	56-112-006	135	56-701-030	148	56-704-004	150
54-785-005	75	56-114-002	135	56-701-031	149	56-704-005	150
54-785-011	75	56-114-003	135	56-701-032	149	56-704-007	150
54-785-012	75	56-114-004	135	56-701-033	149	56-704-008	150
54-785-013	75	56-114-005	135	56-701-034	149	56-704-009	150
54-785-014	75	56-114-006	135	56-701-035	149	56-704-018	150
54-785-016	75	56-122-002	135	56-701-036	149	56-704-035	150
54-785-017	75	56-122-003	135	56-701-037	149	56-705-001	151
54-786-003	65	56-122-004	135	56-701-038	149	56-705-002	151
54-786-013	77	56-122-005	135	56-701-039	149	56-705-003	151
54-786-014	77	56-122-006	135	56-701-040	149	56-705-004	151
54-786-027	77	56-124-002	135	56-701-041	149	56-705-005	151
54-786-028	77	56-124-003	135	56-701-042	149	56-705-008	151
54-789-003	83	56-124-004	135	56-701-047	148	56-705-009	151
54-790-018	72	56-124-005	135	56-701-048	149	56-705-010	151
54-790-019	72	56-124-006	135	56-701-049	149	56-705-026	151
54-790-020	72	56-201-001	190	56-701-050	149	56-705-049	151
54-790-021	72	56-201-004	190	56-701-081	149	56-705-202	191
54-790-022	72	56-201-006	190	56-701-086	148	56-705-204	191
54-790-023	72	56-202-001	191	56-701-087	149	56-705-205	191
54-844-001	83	56-202-002	191	56-702-001	148	56-705-206	191

# Part Number Index

Spectrum part #	Page	Spectrum part #	Page	Spectrum part #	Page	Spectrum part #	Page
56-706-001	151	56-713-004	154	56-721-003	156	56-723-017	159
56-706-002	151	56-713-005	154	56-721-004	156	56-723-018	159
56-706-003	151	56-713-006	155	56-721-005	156	56-723-019	159
56-706-004	151	56-713-007	155	56-721-006	157	56-723-020	159
56-706-005	151	56-713-008	155	56-721-007	157	56-723-021	159
56-706-006	151	56-713-009	155	56-721-008	157	56-723-023	158
56-706-007	151	56-713-010	155	56-721-009	157	56-723-024	158
56-706-008	151	56-713-011	155	56-721-010	157	56-723-025	158
56-706-009	151	56-713-012	155	56-721-011	157	56-723-026	159
56-706-017	151	56-713-013	155	56-721-012	157	56-723-027	159
56-711-001	152	56-713-014	155	56-721-013	157	56-723-028	159
56-711-002	152	56-713-015	155	56-721-014	157	56-723-029	159
56-711-003	152	56-713-016	155	56-721-015	157	56-723-030	159
56-711-004	152	56-713-017	155	56-721-022	157	56-723-031	159
56-711-005	152	56-713-018	155	56-721-024	157	56-723-032	159
56-711-006	153	56-713-019	155	56-721-025	157	56-723-033	159
56-711-007	153	56-713-020	155	56-721-026	157	56-723-034	159
56-711-008	153	56-713-021	154	56-721-027	157	56-723-045	158
56-711-009	153	56-713-022	154	56-721-028	157	56-723-046	159
56-711-010	153	56-713-023	154	56-721-029	157	56-723-047	159
56-711-011	153	56-713-024	155	56-721-030	157	56-723-048	159
56-711-012	153	56-713-025	155	56-721-031	157	56-723-069	158
56-711-013	153	56-713-026	155	56-721-032	157	56-724-001	158
56-711-014	153	56-713-027	155	56-721-033	156	56-724-002	158
56-711-015	153	56-713-028	155	56-721-034	156	56-724-003	158
56-711-018	153	56-713-029	155	56-721-035	156	56-724-004	158
56-711-019	153	56-713-030	155	56-721-036	157	56-724-005	158
56-711-020	153	56-713-031	155	56-721-037	157	56-724-008	158
56-711-021	153	56-713-032	155	56-721-038	157	56-724-009	158
56-711-022	153	56-713-037	154	56-721-039	157	56-724-010	158
56-711-023	153	56-713-038	155	56-721-040	157	56-724-021	158
56-711-024	153	56-713-039	155	56-721-041	157	56-724-046	158
56-711-025	153	56-713-040	155	56-721-042	157	56-725-001	159
56-711-026	153	56-713-045	154	56-721-043	157	56-725-002	159
56-711-027	153	56-714-001	154	56-721-044	157	56-725-003	159
56-711-028	152	56-714-002	154	56-721-045	157	56-725-004	159
56-711-029	152	56-714-003	154	56-721-046	157	56-725-005	159
56-711-030	152	56-714-004	154	56-721-047	157	56-725-019	159
56-711-031	153	56-714-005	154	56-721-063	156	56-725-020	159
56-711-032	153	56-714-006	154	56-721-064	157	56-725-021	159
56-711-033	153	56-714-007	154	56-721-065	157	56-725-064	159
56-711-034	153	56-714-008	154	56-721-066	157	56-725-073	159
56-711-035	153	56-714-017	154	56-721-070	157	56-725-202	191
56-711-036	153	56-714-031	154	56-721-111	156	56-725-204	191
56-711-037	153	56-715-001	155	56-721-112	157	56-725-205	191
56-711-038	153	56-715-002	155	56-722-001	156	56-725-206	191
56-711-039	153	56-715-003	155	56-722-002	156	56-726-001	159
56-711-040	153	56-715-004	155	56-722-003	156	56-726-002	159
56-711-041	153	56-715-005	155	56-722-004	156	56-726-003	159
56-711-042	153	56-715-007	155	56-722-005	156	56-726-004	159
56-711-048	152	56-715-008	155	56-722-008	156	56-726-005	159
56-711-049	153	56-715-009	155	56-722-009	156	56-726-006	159
56-711-050	153	56-715-015	155	56-722-010	156	56-726-007	159
56-711-051	153	56-715-040	155	56-722-027	156	56-726-008	159
56-711-085	153	56-715-202	191	56-722-060	156	56-726-009	159
56-711-086	153	56-715-204	191	56-723-001	158	56-726-021	159
56-711-088	152	56-715-205	191	56-723-002	158	56-731-001	160
56-712-001	152	56-715-206	191	56-723-003	158	56-731-002	160
56-712-002	152	56-716-001	155	56-723-004	158	56-731-003	160
56-712-003	152	56-716-002	155	56-723-005	158	56-731-004	160
56-712-004	152	56-716-003	155	56-723-006	159	56-731-005	160
56-712-005	152	56-716-004	155	56-723-007	159	56-731-006	161
56-712-007	152	56-716-005	155	56-723-008	159	56-731-007	161
56-712-008	152	56-716-006	155	56-723-009	159	56-731-008	161
56-712-009	152	56-716-007	155	56-723-010	159	56-731-009	161
56-712-017	152	56-716-008	155	56-723-012	159	56-731-010	161
56-712-039	152	56-716-009	155	56-723-013	159	56-731-011	161
56-713-001	154	56-716-013	155	56-723-014	159	56-731-012	161
56-713-002	154	56-721-001	156	56-723-015	159	56-731-013	161
56-713-003	154	56-721-002	156	56-723-016	159	56-731-014	161

# Part Number Index

Spectrum part #	Page	Spectrum part #	Page	Spectrum part #	Page	Spectrum part #	Page
56-731-015	161	56-733-028	163	56-741-032	165	56-744-007	166
56-731-018	161	56-733-029	163	56-741-033	165	56-744-008	166
56-731-019	161	56-733-030	163	56-741-034	165	56-744-009	166
56-731-020	161	56-733-031	163	56-741-035	165	56-744-012	166
56-731-021	161	56-733-032	163	56-741-036	165	56-745-001	167
56-731-022	161	56-733-035	163	56-741-037	165	56-745-002	167
56-731-023	161	56-733-036	163	56-741-038	165	56-745-003	167
56-731-024	161	56-733-037	163	56-741-039	165	56-745-004	167
56-731-025	161	56-733-038	163	56-741-040	165	56-745-005	167
56-731-026	161	56-733-046	162	56-741-041	165	56-745-006	167
56-731-027	161	56-734-001	162	56-741-042	164	56-745-007	167
56-731-028	160	56-734-002	162	56-741-043	165	56-745-008	167
56-731-029	160	56-734-003	162	56-741-044	165	56-745-019	167
56-731-030	160	56-734-004	162	56-741-045	165	56-745-027	167
56-731-031	161	56-734-005	162	56-741-063	165	56-746-001	167
56-731-032	161	56-734-006	162	56-741-066	164	56-746-002	167
56-731-033	161	56-734-007	162	56-741-067	165	56-746-003	167
56-731-034	161	56-734-008	162	56-742-001	164	56-746-004	167
56-731-035	161	56-734-012	162	56-742-002	164	56-746-005	167
56-731-036	161	56-734-021	162	56-742-003	164	56-746-006	167
56-731-037	161	56-735-001	163	56-742-004	164	56-746-007	167
56-731-038	161	56-735-002	163	56-742-005	164	56-746-008	167
56-731-039	161	56-735-003	163	56-742-006	164	56-746-009	167
56-731-040	161	56-735-004	163	56-742-007	164	56-746-018	167
56-731-041	161	56-735-005	163	56-742-008	164	56-882-002	183
56-731-042	161	56-735-008	163	56-742-009	164	56-882-003	183
56-731-048	160	56-735-009	163	56-742-022	164	56-882-004	183
56-731-049	161	56-735-010	163	56-743-001	166	56-882-005	183
56-731-050	161	56-735-025	163	56-743-002	166	56-886-002	184
56-731-051	161	56-735-034	163	56-743-003	166	56-886-003	184
56-731-060	161	56-736-001	163	56-743-004	166	56-886-004	184
56-731-076	160	56-736-002	163	56-743-005	166	56-886-005	184
56-731-077	161	56-736-003	163	56-743-006	167	56-889-002	185
56-732-001	160	56-736-004	163	56-743-007	167	56-889-003	185
56-732-002	160	56-736-005	163	56-743-008	167	56-889-004	185
56-732-003	160	56-736-006	163	56-743-009	167	56-889-005	185
56-732-004	160	56-736-007	163	56-743-010	167	56-AXX-XXX-XXXX	187
56-732-005	160	56-736-008	163	56-743-011	167	56-BXX-XXX-X	189
56-732-006	160	56-736-009	163	56-743-012	167	56-EXX-XXX-X-X	179
56-732-007	160	56-736-015	163	56-743-013	167	572019-00100-70	192
56-732-008	160	56-741-001	164	56-743-014	167	572019-00101-70	192
56-732-009	160	56-741-002	164	56-743-015	167	572019-00102-70	192
56-732-023	160	56-741-003	164	56-743-016	167	572019-00103-70	192
56-733-001	162	56-741-004	164	56-743-017	167	572019-00104-70	192
56-733-002	162	56-741-005	164	56-743-018	167	572019-00105-70	192
56-733-003	162	56-741-006	165	56-743-019	167	572019-00106-70	192
56-733-004	162	56-741-007	165	56-743-020	167	572019-00107-70	192
56-733-005	162	56-741-008	165	56-743-021	166	572019-00108-70	192
56-733-006	163	56-741-009	165	56-743-022	166	572019-00109-70	192
56-733-007	163	56-741-010	165	56-743-023	166	57D13-1506-7200	231
56-733-008	163	56-741-011	165	56-743-024	167	57D13-0909-7200	231
56-733-009	163	56-741-012	165	56-743-025	167	57D13-1512-7200	231
56-733-010	163	56-741-013	165	56-743-026	167	57D13-2512-7200	231
56-733-011	163	56-741-014	165	56-743-027	167	57D13-2514-7200	231
56-733-012	163	56-741-015	165	56-743-028	167	57D13-3725-7200	231
56-733-013	163	56-741-017	165	56-743-029	167	57F01-D112-1275	233
56-733-014	163	56-741-018	165	56-743-030	167	57F11-D140-1275	233
56-733-015	163	56-741-019	165	56-743-031	167	57F11-D170-1275	233
56-733-016	163	56-741-020	165	56-743-032	167	57F01-D212-1575	233
56-733-017	163	56-741-021	165	56-743-033	166	57F11-D240-1575	233
56-733-018	163	56-741-022	165	56-743-034	167	57F11-D270-1575	233
56-733-019	163	56-741-023	165	56-743-035	167	57F01-D312-2075	233
56-733-020	163	56-741-024	165	56-743-036	167	57F11-D340-2075	233
56-733-021	163	56-741-025	165	56-743-043	166	57F11-D370-2075	233
56-733-022	163	56-741-026	165	56-744-001	166	57F01-D412-2775	233
56-733-023	163	56-741-027	164	56-744-002	166	57F11-D440-2775	233
56-733-024	163	56-741-028	164	56-744-003	166	57F11-D470-2775	233
56-733-025	163	56-741-029	164	56-744-004	166	57F01-D512-2685	233
56-733-026	163	56-741-030	164	56-744-005	166	57F11-D540-2685	233
56-733-027	163	56-741-031	165	56-744-006	166	57F11-D570-2685	233

# Part Number Index

Spectrum part #	Page	Spectrum part #	Page	Spectrum part #	Page	Spectrum part #	Page
57L12-4339-7200	232	D38999/41	214	SCI-2060-007	94	SCI-9110-503	72
57L12-5767-7200	232	D38999/42	215	SCI-2060-009	94	SCI-9112-273	72
57P13-5216-7200	231	D38999/44	215	SCI-2060-013	94	SCI-9112-503	72
57P12-5216-7a200	231	D38999/46	215	SCI-2060-014	94	SCI-9120-101	72
57R13-4004-7200	232	FCB-XXXX-XXXXXX	22	SCI-2120-014	89	SCI-9120-102	72
57R13-2004-7200	232	FIN-XXXX-XXXXXX	36	SCI-2130-007	91	SCI-9120-103	72
57R13-2006-7200	232	FPB-XXXX-XXXXXX	30	SCI-2130-009	91	SCI-9120-502	72
57R13-1608-7200	232	LC0805M103MANA*	55	SCI-2130-014	91	SCI-9122-101	72
57R13-4012-7200	232	LC0805M104MANA*	55	SCI-2140-004	93	SCI-9122-102	72
57R13-2512-7200	232	LC0805M223MANA*	55	SCI-2140-006	93	SCI-9122-103	72
57R13-1913-7200	232	LC0805M224MANA*	55	SCI-2140-007	93	SCI-9122-502	72
57R13-5013-7200	232	LC0805M473MANA*	55	SCI-2150-000	87	SCI-9200-503	75
57R13-1616-7200	232	LC1206M103MANA*	55	SCI-2150-001	87	SCI-9210-103	75
57R13-2020-7200	232	LC1206M104MANA*	55	SCI-2160-011	94	SCI-9210-273	75
57R13-4022-7200	232	LC1206M223MANA*	55	SCI-2160-012	94	SCI-9220-101	75
57R13-3737-7200	232	LC1206M224MANA*	55	SCI-2160-013	94	SCI-9220-102	75
57R13-5140-7200	232	LC1206M473MANA*	55	SCI-2160-014	94	SCI-9220-502	75
57R13-5025-7200	232	M83723/71/72	218	SCI-2320-004	89	SCI-9310-273	78
57T11-0100-0200	235	M83723/73/74	219	SCI-2320-005	89	SCI-9510-503	81
57T11-0200-0200	235	M83723/77/78	219	SCI-2320-006	89	SCI-9550-102	81
57T11-0362-0200	235	M83723/79	218	SCI-2320-007	89	SCI-9550-332	81
57T11-0400-0200	235	M83723/81	219	SCI-2320-010	89	SCI-9900-000	68
57T12-0050-0330	235	MIL-C-26482	220	SCI-2320-014	89	SCI-9900-153	68
57T12-0075-0330	235	MIL-C-38999-CS	200	SCI-2330-007	91	SCI-9900-303	68
842448-1	60	MIL-C-38999-ES	207	SCI-2330-009	91	SCI-9910-272	68
842448-2	60	MIL-C-83723	216	SCI-2330-010	91	SCI-9910-502	68
9000-103-0019	89	MS27466	201	SCI-2330-012	91	SCI-9920-101	68
9001-100-1010	91	MS27467	209	SCI-2340-004	93	SCI-9920-122	68
9001-100-1013	91	MS27468	202	SCI-2340-009	93	SCI-9920-501	68
9001-100-1025	91	MS27468	208	SCI-2340-013	93	SCI-9925-000	69
9001-100-1080	91	MS27469	208	SCI-2340-014	93	SCI-9925-101	69
9001-100-1081	91	MS27470	208	SCI-2350-000	87	SCI-9925-122	69
9004-100-2017	93	MS27472	204	SCI-2350-001	87	SCI-9925-153	69
9010-100-0049	96	MS27474	204	SCI-2360-006	94	SCI-9925-303	69
9010-100-0054	96	MS27474	210	SCI-2360-007	94	SCI-9925-501	69
9050-100-0011	87	MS27476	211	SCI-2360-011	94	SCI-9925-502	69
9051-100-0000	86	MS27477	210	SCI-2360-014	94	SF0805C101SBNC*	49
9051-101-0018	86	MS27484	210	SCI-3102-000	73	SF0805C220SBNC*	49
9053-100-0001	86	MS27496	201	SCI-3102-002	73	SF0805C221SBNC*	49
9053-100-0002	87	MS27496	209	SCI-3102-007	73	SF0805C470SBNC*	49
9053-100-0008	86	MS27497	203	SCI-3112-000	73	SF0805X102SBNC*	49
9200-300-0025	88	MS27499	204	SCI-3112-002	73	SF0805X222SBNC*	49
9200-303-0095	89	MS27499	211	SCI-3112-007	73	SF0805X223SBNC*	49
9900-381-6004	72	MS27505	202	SCI-3112-100	73	SF0805X471SBNC*	49
9900-381-6005	72	MS27505	209	SCI-3112-102	73	SF1205C101SBNB*	49
9900-381-6006	72	MS27508	203	SCI-3112-107	73	SF1205C220SBNB*	49
9900-381-6013	72	MS27508	211	SCI-3122-000	73	SF1205C221SBNB*	49
9900-381-6020	72	MS27656	202	SCI-3122-002	73	SF1205C470SBNB*	49
9900-381-6021	72	MS3440	222	SCI-3122-007	73	SF1205X102SBNB*	49
9900-381-6022	72	MS3449	223	SCI-3223-000	76	SF1205X222SBNB*	49
9900-381-6026	72	MS3470	222	SCI-3303-000	80	SF1205X223SBNB*	49
9910-381-6002	78	MS3472	222	SCI-3313-000	80	SF1205X471SBNB*	49
9910-381-6003	78	MS3474	223	SCI-3323-000	80	SF1205X473SBND*	49
9910-381-6004	78	MS3475	223	SCI-3513-000	81	SF1806C101SDNB*	49
9920-100-6002	85	PSM1-XXXX-XXX	58	SCI-3523-000	81	SF1806C220SDNB*	49
9923-100-6004	85	PSM4-XXXX-XXX	58	SCI-3543-000	81	SF1806C221SDNB*	49
9932-100-6004	95	SCI-1020-000	86	SCI-3553-000	81	SF1806C470SDNB*	49
9932-100-6005	95	SCI-1020-020	86	SCI-6120-008	96	SF1806C471SDNB*	49
9950-381-6007	75	SCI-1021-000	86	SCI-6120-009	96	SF1806X102SDNB*	49
9950-381-6008	75	SCI-1021-020	86	SCI-6130-009	98	SF1806X103SDNB*	49
9950-381-6009	75	SCI-1150-000	86	SCI-6140-004	99	SF1806X222SDNB*	49
CIN-XXXX-HXXXXX	40	SCI-1150-001	86	SCI-6140-006	99	SF1806X223SDNB*	49
D38999/20	205	SCI-1250-001	87	SCI-6140-007	99	SF1806Y224ZBNE*	49
D38999/20	212	SCI-2030-004	91	SCI-6140-009	99	SSM1-XXXX-XXX	58
D38999/21	212	SCI-2030-005	91	SCI-6320-004	96		
D38999/23	213	SCI-2030-006	91	SCI-6340-004	99		
D38999/24	205	SCI-2030-010	91	SCI-6340-006	99		
D38999/24	213	SCI-2030-013	91	SCI-6340-007	99		
D38999/26	213	SCI-2040-012	93	SCI-9110-100	72		
D38999/40	214	SCI-2040-013	93	SCI-9110-273	72		

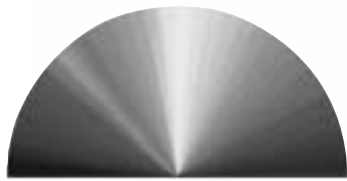

**SPECTRUM CONTROL INC.**

# A **Control Products & Systems** Company

As A Control Products & Systems Company, we strive to meet our customers' needs by providing greater component and system solutions to their design problems. Our family of interference, power and microwave products is now the broadest line in the industry. These engineering driven products deliver unmatched performance in the high frequencies common to new applications.

To satisfy the increased demand that corresponds with our growth, we've conducted a major manufacturing expansion. This additional manufacturing capacity involves all of our facilities and is highlighted by our new plant in Juarez, Mexico. This expansive facility produces components and systems for both of our groups and has received numerous positive customer audits.

**Spectrum  
Control  
de Mexico**

## **Signal & Power Integrity Group**

As a vertically integrated producer of ceramic capacitors and filters, we continue to provide the widest range of discrete EMI filters, filtered connectors, ferrite inductors and filtered power products. In addition, we have extended our ceramic technology to develop our SPECWAVE line of wireless components.

- Low Pass EMI Filters
- Filtered Terminal Blocks and Filter Plates
- Filtered Connectors
- Datacom Connectors
- Ferrite Inductors
- Ceramic Capacitors
- Single Line Filters
- Filtered Terminal Blocks
- Power Entry Modules and Power Line Filters
- Multisection Filters

**EMI Filters  
and Filtered  
Power  
Products**

## **Power Management Systems Group**

Several years ago, we began to apply our fundamental filtering expertise to improve power management. The result is a complete line of standard, yet customizable power distribution units and remote management systems.

- SMARTstart AC/DC Intelligent Power Distribution Units
- SHARPstart AC/DC Power Distribution Units
- Custom Commercial Assemblies

**Frequency  
Control  
Products**

## **Frequency Control Group**

In order to extend our line of microwave products, we recently acquired FSY Microwave, including all products and design expertise. The new Spectrum FSY Microwave family of SPECWAVE components and systems provides a wide range of frequency control solutions.

- Bandpass Filters and Duplexers
- Patch Antenna Elements
- Waveguide Filters
- Lumped Element Filters
- Suspended Substrates
- Cavity Filters
- Coaxial Tubular Filters
- Microwave Custom Assemblies

**Advanced  
Systems**

**ISO 9001**  
CERTIFIED

[www.spectrumcontrol.com](http://www.spectrumcontrol.com)

*Introducing new online tools to help you find the product or system that meets your needs*



### Instant Inventory Information

Our new Check Stock system allows you to gather instant information regarding a particular component's inventory status at Spectrum Control's network of authorized distributors. Selecting the Check Stock icon will provide you with distributor names, part numbers, quantity on hand, online ordering capability and the last date the inventory was updated for that particular component. Use Check Stock to improve your organization's efficiency by simplifying inventory management and reducing inventory



### SPEC SEARCH Online Catalog

We've made finding the right product for your application easier than ever. By using our new online catalog you can tell us the performance parameters you need and we'll help you locate the appropriate product. You start by identifying your mechanical package, add some required electrical characteristics and we'll show you applicable standard part numbers and how they compare to your specifications.



### Online Interactive Design System

New Design Direct allows you to work with our engineers in a collaborative online effort to develop a custom solution tailored to your specific needs. After registering on our site, you'll be able to create and track your project, entirely online. As our engineering team makes changes to your project, you'll receive an e-mail with a direct link to see the current status and provide feedback. Designing a custom solution has never been easier.

*To see all of our new online tools,  
come visit us @ [www.spectrumcontrol.com](http://www.spectrumcontrol.com)*





SPECTRUM CONTROL INC.

# A Control Products & Systems Company

## Signal & Power Integrity Products

- Ferrite beads & inductors
- Surface mount filters
- Discrete EMI filters
- Filter plates
- Filter connectors
- Gaskets & shielding
- Ceramic capacitors
- Single line filters
- Filtered terminal blocks
- Power entry & power line filters
- Military/multisection filters
- EMC testing

[www.spectrumcontrol.com](http://www.spectrumcontrol.com)

## Corporate Headquarters

8031 Avonia Road  
 Fairview, Pennsylvania 16415  
 Phone: 814-474-2207  
 Fax: 814-474-2208 **NEW**

## Signal & Power Integrity

8061 Avonia Road  
 Fairview, Pennsylvania 16415  
 Phone: 814-474-1571  
 Fax: 814-474-3110

## Sales Offices

**NORTH AMERICA** **NEW**  
 6798 Oak Hall Lane  
 Columbia, Maryland 21045  
 Phone: 301-916-2919  
 Fax: 301-916-2910

**EUROPE**  
 Spectrum Control GmbH  
 Hansastrasse 6  
 91126 Schwabach, Germany  
 Phone: (49)-9122-795-0  
 Fax: (49)-9122-795-58

*For additional information regarding Spectrum Control, our full line of EMI filtering and power products and our many new products, call us or contact our web site at <http://www.spectrumcontrol.com>*

*Spectrum Control, Inc. reserves the right to alter the specifications provided in this publication. Consult factory for current specifications.*

**ISO 9001**  
CERTIFIED

## Frequency Control Products

- Resonators
  - Bandpass filters & duplexers
  - Patch antenna elements
  - Waveguide filters
  - Combiners
  - Couplers
  - Duplexer-LNA assemblies
  - Lumped element filters
  - Suspended Substrates
  - Cavity filters
  - Coaxial tubular filters
  - Microwave custom assemblies
  - Tower mount amplifiers
- [www.specwave.com](http://www.specwave.com)

## Power Management Systems

- AC/DC power distribution units
  - & remote reboot power management systems
  - Custom assemblies
  - Power strips
- [www.specpower.com](http://www.specpower.com)

Represented or Distributed by: