

853 SERIES



High Temperature Fire Wall Connectors EN2997 / ESC Qualified



SOURIAU
Connection Technologies

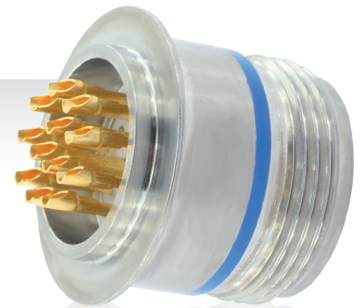
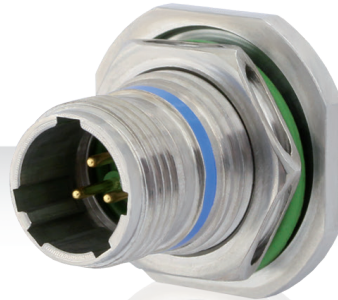
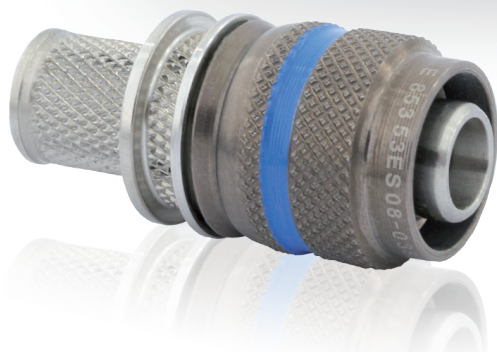

Presentation

MIL-DTL-83723 was designed to be a high temperature, high vibration withstanding connector, but had some important drawbacks:

- Uncertain bottoming,
- Risk of unlocking under vibration,
- No torque specification,
- No scoop proof versions.

To improve on these drawbacks, EN2997 standard includes:

- 360° teeth enable additional backshell positions,
- Additional barriers to leakage.
- Improved shielding resistance due to shell to shell bottoming,
- Self locking mechanism on every plug allows a higher resistance to vibration,

SOURIAU enhanced the standard definition with some additional features:

- Thermoplastic material achieves a better insulation resistance and a high resistance to standard fire tests,
- Qualified as per EN2997 for both stainless steel and aluminum versions, **SOURIAU** has one of the widest ranges on the market.

SOURIAU made these improvements to give our customers the best choice for procuring high performance connectors.

Contents

Overview

Typical applications	6
Features & Benefits	7
Product overview	8
Available configurations	9
Contact layouts	10

Product Ranges

Standard version.....	16
Scoop proof version	24
Integrated backshell version	28
Power & Quadrax version.....	33
Hermetic version	36

Contacts & Accessories

Contacts	44
Wiring instructions	49
Tooling	50
Accessories & Protective caps.....	51

Range Extension

230V connector	56
Fire resistant seal	56
Power contacts for PCB	57
Customizable shunted plug	57
Hermetic connector with removable contact ..	58
Filtered connector	58

853 SERIES

853 Series

Overview

■ Typical applications	6
■ Features & Benefits	7
■ Product overview	8
■ Available configurations	9
■ Contact layouts	10
■ Contact layouts matrix	13

Typical applications



Power & Actuation



External lighting



Landing gear

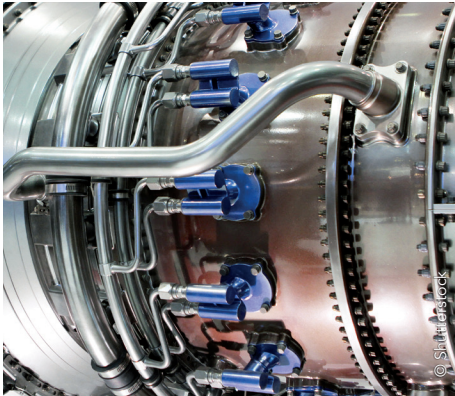

Fuel Management



Sensors

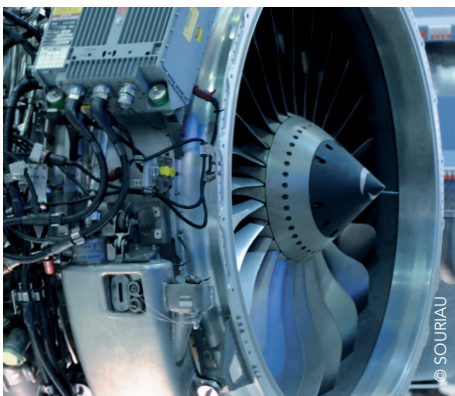

Engines

Features & Benefits

**FIRE
WALL**

High Temperature Connector

Resist up to 260°C (500°F).
Flame test per EN 2591.

**SALT
SPRAY**

Excellent Corrosion Performances

Up to 500 hours salt spray.

**HIGH
VIB**

Upgraded Vibration Performances

Self locking coupling mechanism to resist the highest vibration encountered.

**EMI
RFI**

EMI & Lightning Resistance

Protection of the signal thanks to:

- . EMI grounding ring
- . Shell to shell bottoming
- . 360° rear accessory teeth

**EN2997
ESC**

Qualified Product

Qualified per ASD Cert EN2997 and ESC Standards.
MIL-83723 Series III based design, including additional features,
to respond to today's aircraft's harshest needs.

Product overview

Scoop Proof

See page 24

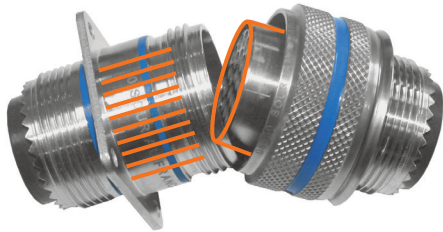

- ▶ For blind mate connection.
- ▶ ESC11 qualified.

Integrated Backshell

See page 28

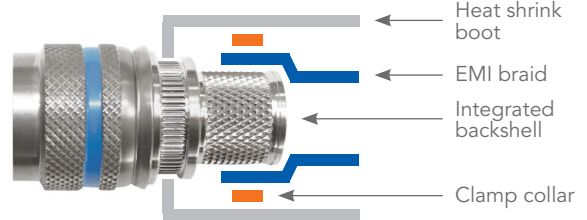

- ▶ For weight saving solutions.
- ▶ ESC15 and ESC16 qualified.

Standard version

See page 16

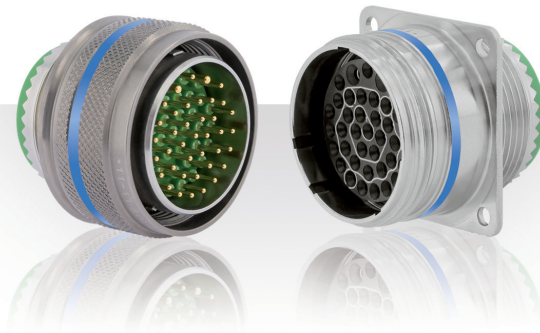

Quadrax & Power Contacts

See page 33



- ▶ Quadrax contacts for high speed ethernet network.
- ▶ Power contacts for high power current under temperature and vibration constraints.
- ▶ ABS qualified solution.

Hermetic version

See page 36

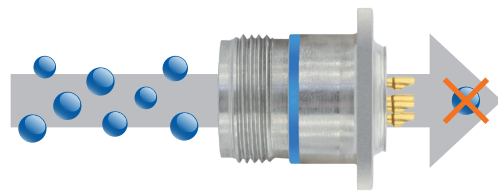

- ▶ For hermetic interface or space constrained application.
- ▶ Leak rate <math>< 10^{-7}</math> atm.cm³/s.
- ▶ Solder cup & PC Tail contacts.

Available configurations

From your need...				... to our solution										RoHS	REACH
T° class	Salt spray	Shell material & plating	Integrated backshell	Scoop proof	Clinch nuts	Hermetic	High vibration	Plug with RFI screening ring	Plug without screening ring	Square flange receptacle	Jam nut receptacle	Solder mount receptacle			
175°C	500H	Aluminum olive drab cadmium					85333W EN2997WS6	85334W EN2997W6	85330W EN2997WS0	85337W EN2997WS7	-				
			Yes					EN2997WSC*	-	EN2997WSA*	-	-	Yes	Yes	
200°C	48H	Aluminum nickel					85333R EN2997RS6	85334R EN2997R6	85330R EN2997RS0	85337R EN2997RS7	-		Yes	Yes	
			Yes					EN2997RSC*	-	EN2997RSA*	-	-	Yes	Yes	
	500H	Aluminum black anodized						-	85334A	85330A	85337A	-	Yes	Yes	
								85333K EN2997S6	85334K EN2997K6	85330K EN2997S0	85337K EN2997S7	-	Yes	Yes	
			Yes			Yes		-	-	85332Y EN2997Y0	85337Y EN2997Y7	85331Y EN2997Y1	Yes	Yes	
			Yes		Yes			85353KS EN2997SC	-	85350KS EN2997SA	-	-	Yes	Yes	
							-	-	85355KS* EN2997SD*	-	-	Yes	Yes		
260°C	500H	Stainless steel					85333E EN2997SE6 ESC10SE6 BACC63CM**	85334E EN2997KE6 ESC10KE6	85330E EN2997SE0 ESC10KE0 ESC10SE0 BACC63CN**	85337E EN2997SE7	-	Yes	Yes		
					Yes			-	-	85332YE EN2997YE0 ESC10YE2	85337YE EN2997YE7 ESC10YE3	85331YE EN2997YE1 ESC10YE1	Yes	Yes	
				Yes				85346SE ESC11SE6	85346KE ESC11KE6	85340SE 85340KE ESC11SE0 ESC11KE0	-	-	Yes	Yes	
			Yes					8535CES 85353ES EN2997SEC ESC15SE7	8535EES 85354ES EN2997KEC ESC15KE7	8535AES 85350ES EN2997SEA ESC15KE2	-	-	Yes	Yes	
			Yes			Yes		85353KV EN2997SVC*	85354KV EN2997KVC ESC15KV7	85350KV EN2997SVA* ESC15KV2*	-	-	Yes	Yes	
			Yes		Yes	Yes		-	-	85355KV EN2997SVD* ESC15KV4	-	-	Yes	Yes	
			Yes		Yes			-	-	8535DES* 85355ES* EN2997SED* ESC15KE4*	-	-	Yes	Yes	
			Yes	Yes				85363ES ESC16SE7	85364ES ESC16KE7	85360ES ESC16KE2	-	-	Yes	Yes	
			Yes	Yes			Yes	-	85364KV ESC16KV7	ESC16KV2*	-	-	Yes	Yes	
			Yes	Yes	Yes		Yes	-	-	85365KV ESC16KV4	-	-	Yes	Yes	

* Please consult us. **Only delivered without contact.

Contact layouts 8533/8535 Series

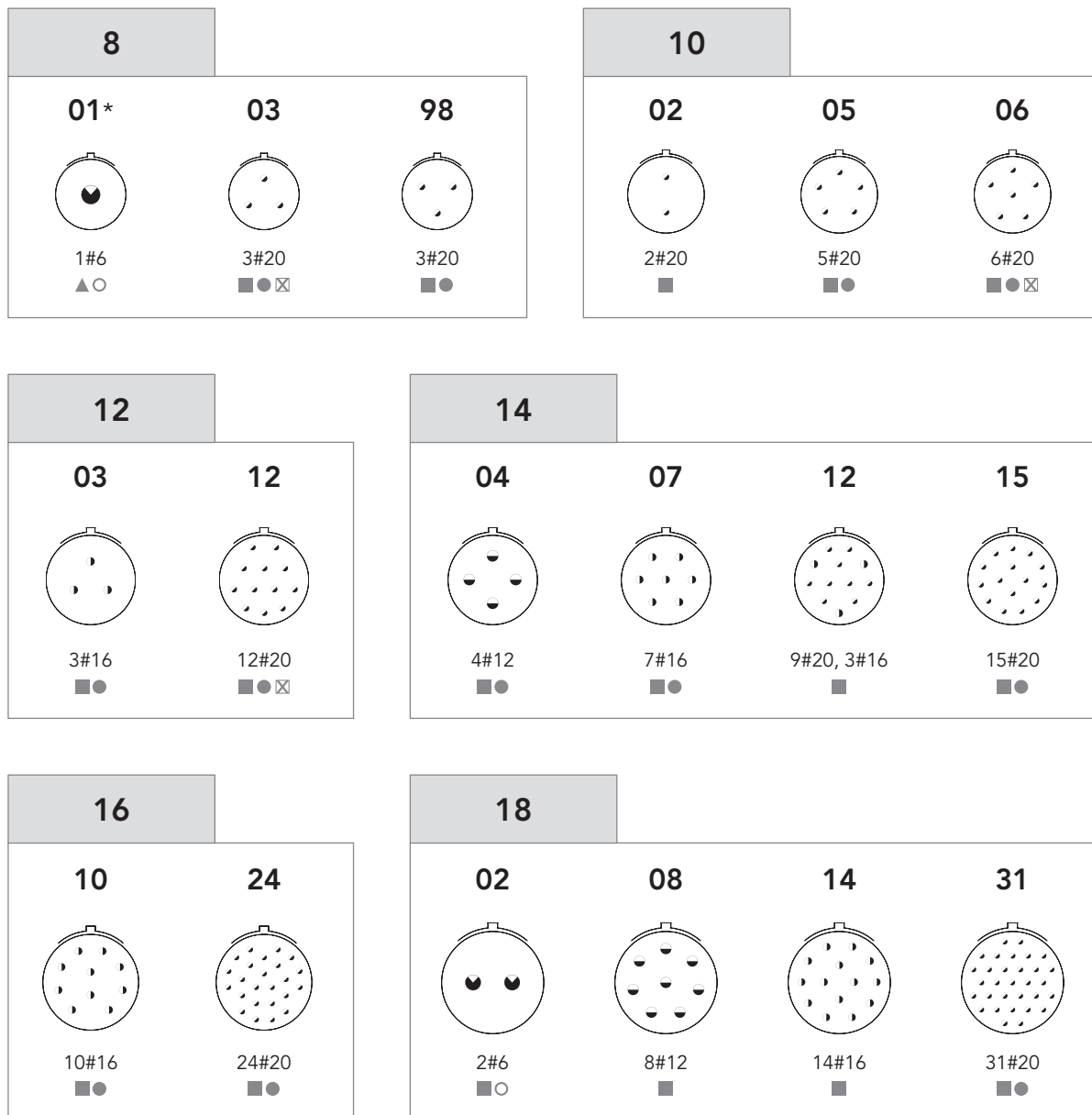

Connector type		Contact size	
▲	Class 200°C	●	Contact #20
■	Classes 200°C & 260°C	◐	Contact #16
●	Hermetic 200°C & 260°C (8533 only)	◑	Contact #12
☒	Fuel tank	◕	Contact #8 quadrax & Contact #6 power
○	8533 only (ABS)	◖	Contact #4 power

* Quadrax layout only, #8 Quadrax contact compatible with #6 cavity.

Coordinates information: please consult us.

Contact layouts 8533/8535 Series

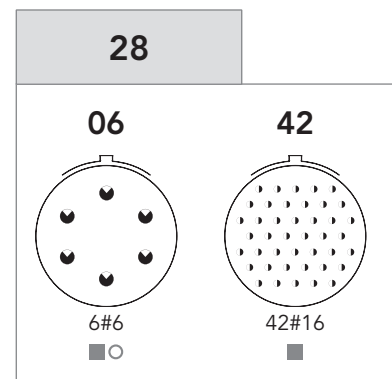
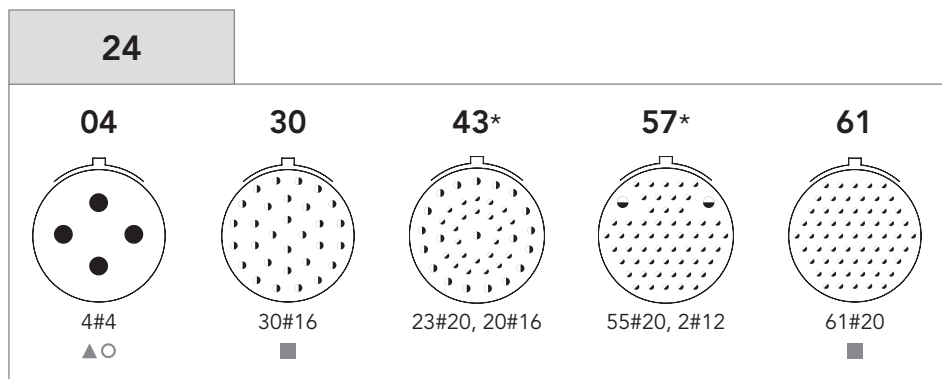
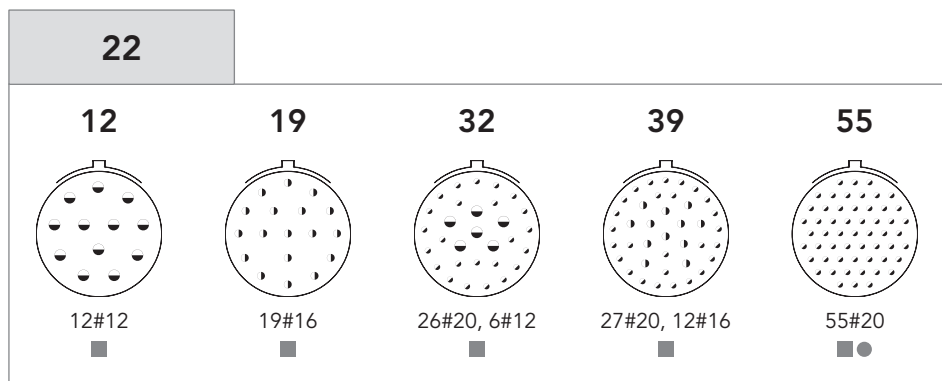
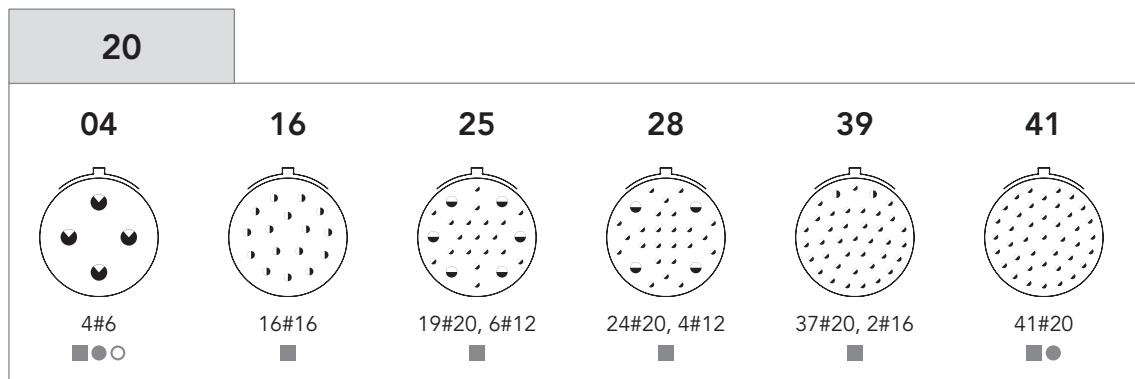

Connector type		Contact size	
▲ Class 200°C	■ Classes 200°C & 260°C	● Contact #20	● Contact #8 quadrax & Contact #6 power
● Hermetic 200°C & 260°C (8533 only)		○ Contact #16	● Contact #4 power
☒ Fuel tank	○ 8533 only (ABS)	● Contact #12	
* Please consult us.		Coordinates information: please consult us.	

Contact layouts 8534/8536 Series

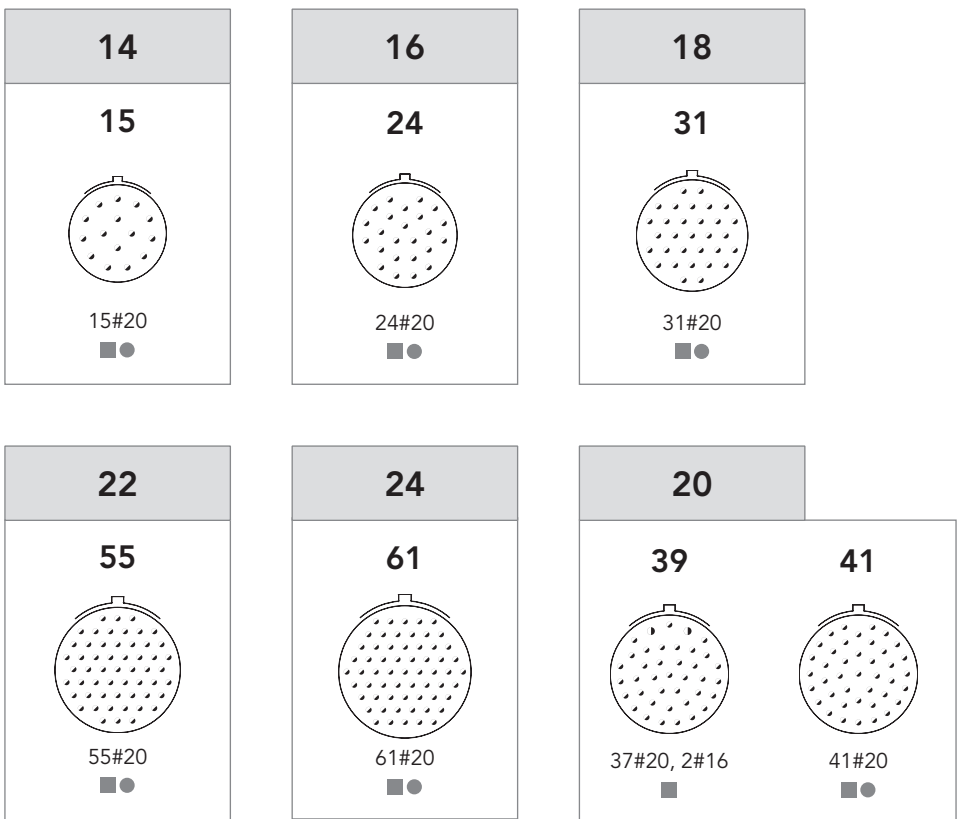

Connector type		Contact size	
▲ Class 200°C	■ Classes 200°C & 260°C	○ Contact #20	● Contact #8 quadrax & Contact #6 power
● Hermetic 200°C & 260°C (8533 only)		◐ Contact #16	● Contact #4 power
⊗ Fuel tank	○ 8533 only (ABS)	◑ Contact #12	

Coordinates information: please consult us.

Contact layouts (matrix)

Shell size	Layout	8533	EN2997	ESC10	ABS Power & Quadrax	8533 hermetic	EN2997 hermetic	8533 spec. 022	ESC10 hermetic	8535	ESC15	8534 8536	ESC11 ESC16	Number of contacts					
														#20	#16	#12	#8	#6	#4
08	08-01	Yes			Yes ⁽²⁾												1		
	08-03	Yes	Q	Q		Yes	Q	Yes	Q	Yes	Q			3					
	08-98	Yes	Q	Q		Yes	Q		Q	Yes	Q			3					
10	10-02	Yes								Yes				2					
	10-05	Yes	Q	Q		Yes	Q		Q	Yes	Q			5					
	10-06	Yes	Q			Yes	Q			Yes	Q			6					
12	12-03	Yes	Q	Q		Yes	Q		Q	Yes	Q				3				
	12-12	Yes	Q	Q		Yes	Q	Yes	Q	Yes	Q			12					
14	14-04	Yes	Q	Q		Yes	Q		Q	Yes	Q					4			
	14-07	Yes	Q	Q		Yes	Q		Q	Yes	Q				7				
	14-12	Yes	Q							Yes				9	3				
	14-15	Yes	Q	Q		Yes	Q		Q	Yes	Q	Yes	Q	15					
16	16-10	Yes	Q	Q		Yes	Q		Q	Yes	Q				10				
	16-24	Yes	Q	Q		Yes	Q		Q	Yes	Q	Yes	Q	24					
18	18-02	Yes			Yes														2
	18-08	Yes	Q	Q						Yes						8			
	18-14	Yes	Q	Q						Yes	Q				14				
	18-31	Yes	Q	Q		Yes	Q		Q	Yes	Q	Yes	Q	31					
20	20-04	Yes			Yes	Yes													4
	20-16	Yes	Q							Yes					16				
	20-25	Yes	Q							Yes				19		6			
	20-28	Yes	Q							Yes				24		4			
	20-39	Yes	Q	Q						Yes	Q	Yes	Q	37	2				
	20-41	Yes	Q	Q		Yes	Q	Yes	Q	Yes	Q	Yes	Q	41					
22	22-12	Yes	Q	Q					Q	Yes							12		
	22-19	Yes	Q	Q					Q	Yes	Q				19				
	22-32	Yes	Q							Yes				26		6			
	22-39	Yes	Q							Yes				27	12				
	22-55	Yes	Q	Q		Yes	Q		Q	Yes	Q	Yes	Q	55					
24	24-04	Yes			Yes														4
	24-30	Yes	Q	Q						Yes	Q				30				
	24-43	Yes								Yes				23	20				
	24-57	Yes								Yes				55		2			
	24-61	Yes	Q	Q					Q	Yes	Q	Yes	Q	61					
28	28-06	Yes			Yes														6
	28-42	Yes	Q ⁽¹⁾	Q						Yes	Q				42				

Yes SOURIAU's layout

Q SOURIAU's layout & Layout according to corresponding norm

(1) Only developed for square flange receptacle all classes and stainless steel plug (for other configuration, please consult us)

(2) Quadrax contact only

853 SERIES

853 Series

Product Ranges

■ 8533 Series - Standard version	16
■ 8534 Series - Scoop proof version	24
■ 8535/8536 Series - Integrated backshell version	28
■ 8533 Series - Power & Quadrax version	33
■ 8533 Series - Hermetic version	36

Description

- Stainless steel screw coupling connector derived from MIL-C-83723 & designed for use in harsh aviation environments:
 - . high vibration resistance
 - . high temperature resistance (up to 260°C)
 - . Fireproof (1100°C)
- Qualified to EN2997 standard and to ESC10 standard
- Large array of crimp contacts, EN3155 and ESC30 qualified:
 - . size 12, 16 & 20 standard contacts
 - . size 12, 16 & 20 thermocouple contacts for temperature measurement
- Fuel immersion version available

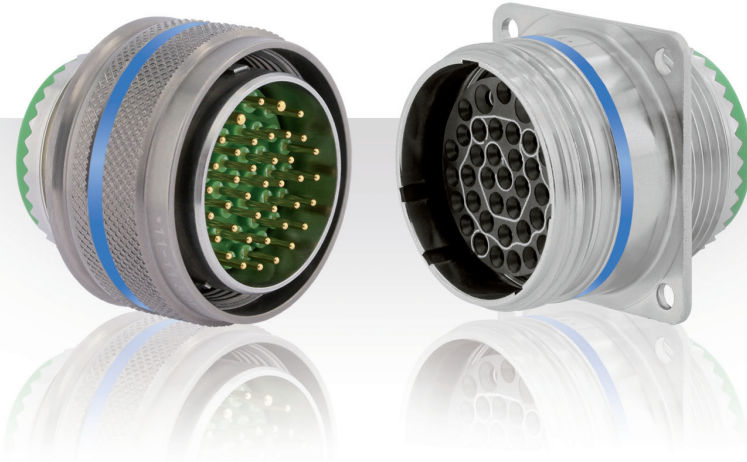

Technical features

Mechanical

- **Shell:**
 - . aluminum alloy (class R, W and A)
 - . stainless steel (class K and E)
- **Plating:**
 - . nickel (class R)
 - . olive green cadmium (class W)
 - . black anodized (class A)
 - . passivated (class K and E)
- **Grommet and seal:**
 - . silicone elastomer
- **Insulator:**
 - . thermoplastic
- **Contact body:**
 - . copper alloy
- **Contact plating:**
 - . gold over nickel
- **Contact retention:**
 - . size 20: 90 N
 - . size 16: 110 N
 - . size 12: 130 N
- **Mating cycles:**
 - . 250 mating cycles (class R, W and A)
 - . 500 mating cycles (class K and E)
- **Shock:**
 - . 300 m/s² (30g) during 3 ms
- **Vibration:**
 - . random 5 Hz to 2000 Hz at 1G²/Hz (2 x 8 hours)

Electrical

- **Dielectric withstanding:**

Altitude	Service I
Sea level	1500 Vrms
15 000 m	600 Vrms
21 000 m	400 Vrms
33 000 m	200 Vrms
- **Contact resistance:**
 - . initial contact resistance at ambient temperature as per EN 2997 and EN3155

Contact size	20	16	12
Resistance mΩ	7.3	3.8	3.5
- **Insulation resistance:**
 - . 5000 MΩ at 500 Vdc
- **Max current rating per contact:**

Contact size	20	16	12
Rating (A)	7.3	13	23
- **Electrical continuity:**
 - . 5 mΩ max with RFI shielding
 - . 60 mΩ without RFI shielding
- **Shielding:**
 - . to 100 MHz at 1 GHz attenuation 65 dB
- **Lightning strike (3K & 3E classes):**
 - . 15A according D0160, wave 5A

Environmental

- **Operating temperature:**
 - . class W: -65° to +175°C (-149° to +347°F)
 - . class R, A and K: -65° to +200°C (-149° to +392°F)
 - . class E: -65° to +260°C (-149° to +500°F)
 - . fuel tank long term immersion version specification 22 limited to +105°C max
- **Leakage:**
 - . as per 2591-312:
 - Method B differential pressure: 100kPa
 - Maximum leakage flow: 16x10⁻⁶ m³/h
- **Salt spray:**
 - . 48 hours (class R)
 - . 500 hours (class W, K, E and A)
- **Resistance to fluids:**
 - . MIL-H 5606 - SKYDROL 500 B4 - LD4 - JP5 - MIL-L 7870A - MIL-L 23699 - MIL-L 7808 - MIL-C 25769 - MIL-A 8243
- **Fire resistance:**
 - . as per EN 2591-318:
 - 6 min under a 1100°C flame without electrical perturbation, plus 14 min with no flame propagation (ES class)

Fuel resistance

- **Standard version:**
 - . as per EN2997
- **Long term immersion (specification 22):**
 - . as per PREN3645 3 cycles of 96 hours in fuel

Ordering information

Standards connectors - SOURIAU part numbers

Basic Series	8533	0	R	S	14	15	P	N	-
Shell type:									
0: Square flange receptacle									
3: Plug with RFI screening ring									
4: Plug without RFI screening ring									
7: Jam nut receptacle									
Class:									
W: 175°C aluminum olive drab cadmium conductive plating									
R: 200°C aluminum nickel conductive plating									
A: 200°C aluminum black anodized non conductive plating									
K: 200°C stainless steel									
E: 260°C stainless steel									
S: With 360° teeth									
Shell size: 08, 10, 12, 14, 16, 18, 20, 22, 24, 28									
Contact layout: See page 10									
Contact type:									
P: Pin									
S: Socket									
Orientation: N, 6, 7, 8, 9, Y (see page 20)									
Specification:									
None: Connector supplied with standard contacts									
L: Connector supplied without contact									
08: Connector supplied with large barrel contacts									
22: Fuel immersion version									
68: Connector supplied with contacts #20 large barrel and standard contact #16									

EN2997 Qualified products

Basic Series	EN2997	RS0	14	15	M	N
Class & Shell type:						
Plug without RFI shielding ring:						
W6: 175°C Aluminum olive-green cadmium plating, conductive finish						
R6: 200°C Aluminum nickel conductive plating						
K6: 200°C Stainless steel						
KE6: 260°C Stainless steel						
Plug with RFI shielding ring:						
WS6: 175°C Aluminum olive-green cadmium, conductive plating						
RS6: 200°C Aluminum nickel, conductive plating						
S6: 200°C Stainless steel						
SE6: 260°C Stainless steel						
Square flange receptacle:						
WS0: 175°C Aluminum olive-green cadmium, conductive plating						
RS0: 200°C Aluminum nickel, conductive plating						
S0: 200°C Stainless steel						
SE0: 260°C Stainless steel						
Jam nut receptacle:						
WS7: 175°C Aluminum olive-green cadmium, conductive plating						
RS7: 200°C Aluminum nickel, conductive plating						
S7: 200°C Stainless steel						
SE7: 260°C Stainless steel						
Shell size: 08, 10, 12, 14, 16, 18, 20, 22, 24, 28						
Contact layout: See page 10						
Contact type:						
M: Male contact			F: Female contact			
A: Connector delivered without male contact			B: Connector delivered without female contact			
C: Connector delivered with male contact #20 large barrel			D: Connector delivered with female contact #20 large barrel			
Orientation: N, 6, 7, 8, 9, Y (see page 20)						

ESC10 Qualified products

Basic Series	ESC10	KE	0	10	05	P	N	0
Shell type: KE: 260°C stainless steel: standard receptacle; plug without RFI screening ring SE: 260°C stainless steel: standard receptacle; plug with RFI screening ring								
Shell type: 0: Square flange receptacle 6: Plug								
Shell size: 08, 10, 12, 14, 16, 18, 20, 22, 24, 28								
Contact layout: See page 13 for layouts according to ESC10								
Contact type: P: Pin S: Socket								
Orientation: N, 6, 7, 8, 9, Y (see page 20)								
Variant identifier: 0: Standard connector delivered without contact								

Connector weight Mass max. (g) less contact

Shell size	Square flange		Jam nut		Plug	
	Stainless steel	Aluminum	Stainless steel	Aluminum	Stainless steel	Aluminum
08	19	11	32	15	31	14
10	28	16	41	21	44	21
12	39	27	58	30	57	26
14	51	30	68	35	72	38
16	62	34	82	46	82	39
18	73	36	88	51	95	43
20	82	40	100	56	108	48
22	90	51	123	69	121	65
24	105	58	137	82	134	67
28	126	88	191	120	160	103

Mass of crimp contacts

Contact size	Mass (g)	
	Pin	Socket
20	0.24	0.29
16	0.53	0.59
12	1.15	1.28
6	3.6	4.8
4	7.3	8.5

Dimensions

Plug

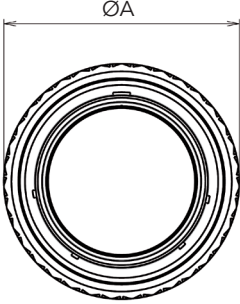

ØA

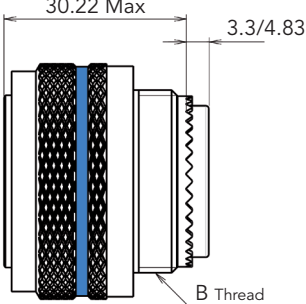

30.22 Max
3.3/4.83
B Thread

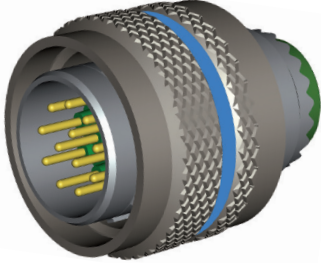

Shell size	08	10	12	14	16	18	20	22	24	28
A Max	21.30	24.90	29.60	31.24	34.42	37.34	41.91	44.07	47.24	55.24
B Thread	1/2"-20 UNF 2A	5/8"-24 UNEF 2A	3/4"-20 UNEF 2A	7/8"-20 UNEF 2A	1"-20 UNEF 2A	1-1/16"-18 UNEF 2A	1-3/16"-18 UNEF 2A	1-5/16"-18 UNEF 2A	1-7/16"-18 UNEF 2A	1-3/4"-18 UNEF 2A

Note: All dimensions are in millimeters (mm)

Square flange receptacle

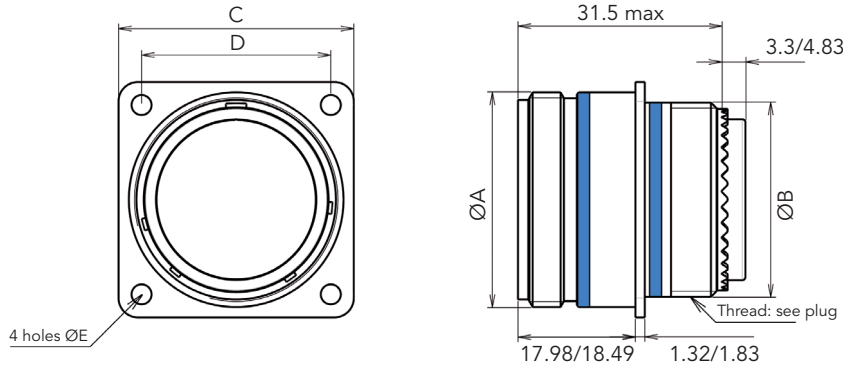

Shell size	08	10	12	14	16	18	20	22	24	28
A Max	14.27	17.67	22.22	23.77	26.97	30.15	33.32	36.49	39.67	46.02
B Max	12.7	15.88	19.05	22.23	25.40	26.97	30.18	33.32	36.53	44.45
C Max	20.75	23.93	26.32	28.71	31.88	34.24	36.63	39.80	43.39	50.93
D	15.09	18.26	20.62	23.01	24.61	26.97	29.36	31.75	34.92	39.67
E	3.10/3.30								3.68/3.91	

Jam nut receptacle

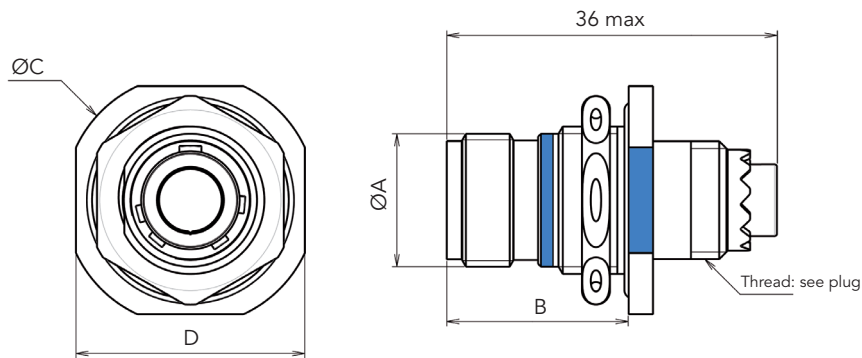

Shell size	08	10	12	14	16	18	20	22	24
A Max	14.27	17.67	22.22	23.77	26.97	30.15	33.32	36.49	39.67
B Max	19.84	19.84	19.84	19.84	19.84	19.84	19.84	19.84	19.84
C Max	27.38	30.28	35.05	38.51	41.68	44.86	49.63	52.78	55.42
D Max	24.89	28.04	32.79	35.33	38.51	41.68	44.86	49.63	52.81

Note: All dimensions are in millimeters (mm)

Panel cut out

Type 0
Square flange receptacle

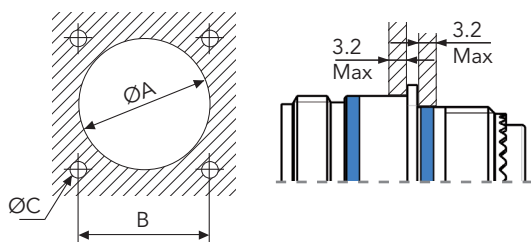

Type 7
Jam nut receptacle

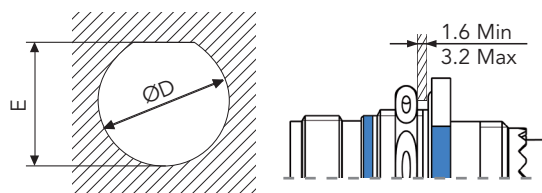

Shell size	8	10	12	14	16	18	20	22	24	28
A min	15.8	18.7	23.4	24.9	28.3	31.1	34.5	37.5	40.6	48
B	15.09	18.26	20.62	23.01	24.61	26.97	39.36	31.75	34.92	39.67
C	3.2								3.8	
D Min	16.00	19.17	23.92	25.52	28.70	31.87	35.05	38.22	41.40	-
E Min	15.24	18.41	23.16	24.76	27.94	30.99	34.16	37.33	40.51	-

Minimum space between square flange or jam nut receptacles

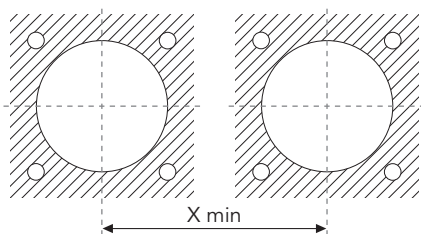

Shell size	8	10	12	14	16	18	20	22	24	28
Y min (norm value)	31.70	34.90	39.60	41.25	44.45	47.35	51.90	54.10	57.25	65.25

$$X \text{ min} = Y/2 \text{ (connector one)} + Y/2 \text{ (connector two)}$$

Example of minimum space between a connector size 8 and a connector size 14:
 $X \text{ min} = 31.70/2 + 41.25/2 = 36.475 \text{ mm}$

Orientation

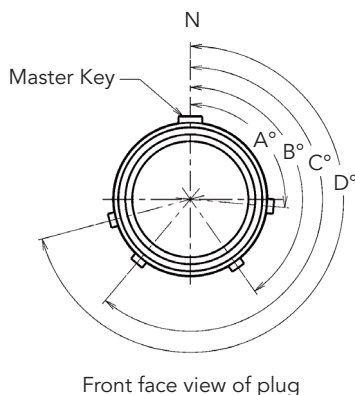

Shell size	Angles	N	6	7	8	9	Y
08	A°	105	102	80	35	64	-
	B°	140	132	118	140	155	-
	C°	215	248	230	205	234	-
	D°	265	320	312	275	304	-
10	A°	105	102	80	35	64	25
	B°	140	132	118	140	155	115
	C°	215	248	230	205	234	220
	D°	265	320	312	275	304	270
12 to 28	A°	105	18	92	84	24	98
	B°	140	149	152	152	135	152
	C°	215	192	222	204	199	268
	D°	265	259	342	334	240	338

Note: All dimensions are in millimeters (mm)

Backshells

Aluminum shrink boot adapters

Shrink boot adapter (removable) Type 60-1

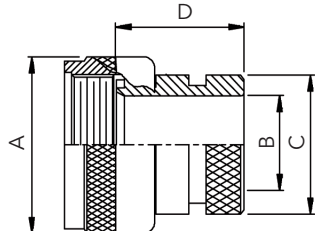

Shrink boot adapter (non removable) Type 60-2G

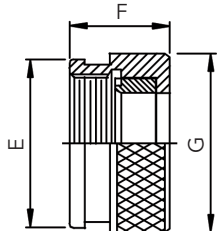

Basic series M85049/ 60-1 W 10

Backshell type:

- 60-1: Shrink boot adapter
- 60-2G: Shrink boot adapter

Plating:

A: Black anodized

N: Nickel

W: Olive green cadmium

Shell size:

08, 10, 12, 14, 16, 18, 20, 22, 24, 28

Shell size	A Max	B Min	C Max	D Max	E Max	F Max	G Max
08	15.67	6.35	13.54	21.13	16.69	13.72	17.48
10	18.64	9.02	15.37	21.13	19.66	13.72	20.4
12	21.79	12.47	19.66	21.13	22.81	13.72	23.83
14	24.99	14.35	21.29	21.13	26.01	13.72	27.0
16	28.24	17.53	24.46	21.13	29.26	13.72	31.45

Shell size	A Max	B Min	C Max	D Max	E Max	F Max	G Max
18	30.94	19.53	26.47	21.13	31.57	13.72	33.27
20	34.16	22.71	30.91	21.13	34.8	13.72	36.47
22	37.29	25.88	34.42	21.13	36.65	13.72	39.62
24	40.46	28.80	36.65	21.13	41.10	13.72	42.82
28	50.01	34.77	43.41	25.25	50.01	17.83	52.37

Aluminum plastic collar

Straight plastic collar Type 53

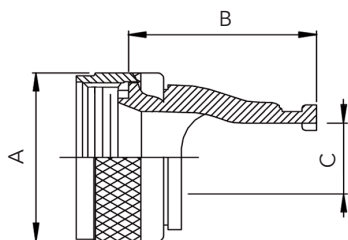

45° plastic collar Type 54

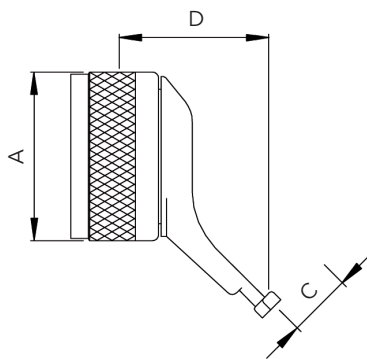

90° plastic collar Type 55

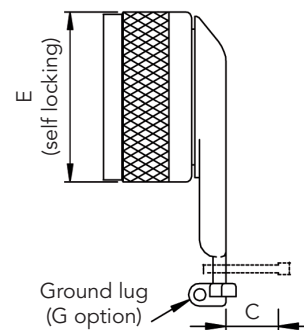

Basic series M85049/ 55 - 10 A

Backshell type:

- 53: Straight plastic collar
- 54: 45° plastic collar
- 55: 90° plastic collar

Configuration (55 type only):

- : Standard without self-locking
- S: Self-locking
- G: Self locking with grounding lug

Shell size: 08, 10, 12, 14, 16, 18, 20, 22, 24

Plating:

A: Black anodized

W: Olive green cadmium

Shell size	A Max	B Max	C	D Max	E Max
08	15.67	24.23	6.60	31.29	16.68
10	18.64	24.23	9.27	31.29	19.86
12	21.79	24.23	12.73	31.29	23.79
14	24.99	30.58	14.60	31.29	26.67
16	28.24	30.58	17.78	31.29	31.47

Shell size	A Max	B Max	C	D Max	E Max
18	30.94	30.58	19.79	31.29	35.00
20	34.16	33.27	22.96	37.64	38.10
22	37.29	36.32	26.14	37.64	41.42
24	40.46	39.62	29.06	37.64	44.50

Note: All dimensions are in millimeters (mm)

Backnut and cable clamp

Backnut
Type 31 (aluminum)
Type 01 (stainless steel)

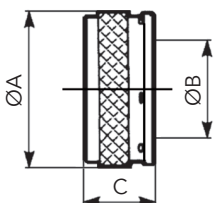

Straight cable clamp
Type 52 (aluminum)
Type 02 (stainless steel)

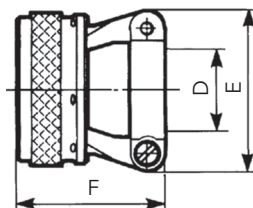

Elbow cable clamp
Type 51 (aluminum)

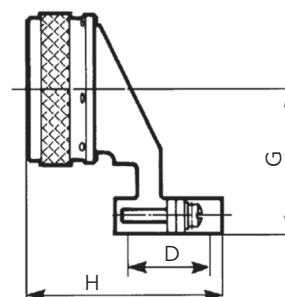

Aluminum backshell	852	31	N	14
--------------------	-----	----	---	----

Backshell type:

- 31: Backnut
- 52: Straight cable clamp
- 51: Elbow cable clamp

Plating:

- A: Black anodized
- N: Nickel
- W: Olive green cadmium

Shell size: 08, 10, 12, 14, 16, 18, 20, 22, 24

Stainless steel backshell	8527	01		14
---------------------------	------	----	--	----

Backshell type:

- 01: Backnut
- 02: Straight cable clamp

Shell size: 08, 10, 12, 14, 16, 18, 20, 22, 24

A: Mandatory suffix for backshell type 02

Shell size	A Max	B	C±0.7	D±0.15	E Max	F Max	G Max	H Max	Torque values Nm
08	15.67	6.85	12.85	4	19.25	22.61	20.50	27.96	8.6
10	18.64	9.50		6.85	20.45	25.40	22.00	30.04	11.5
12	21.79	12.90		10.15	24.35	28.60	23.60	34.95	16.1
14	24.99	14.85		11.7	25.85	28.58	25.20	36.47	17.3
16	28.24	18.03		15.5	32.75	31.75	26.80	40.25	17.3
18	30.94	20.04		17.5	36.15	38.10	31.30	43.10	17.3
20	34.16	23.21		20.7	38.75	41.28	32.90	46.27	20.7
22	37.29	26.39		23.9	41.25	43.55	34.50	49.45	20.7
24	40.46	29.30		27	44.35	47.62	36.10	52.62	20.7

Length - mated/unmated connectors with backshells

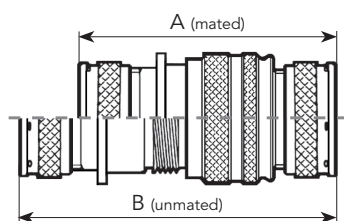

- Backnut - Type 31 or Type 01
- + Square flange receptacle
- + Plug
- + Backnut - Type 31 or Type 01

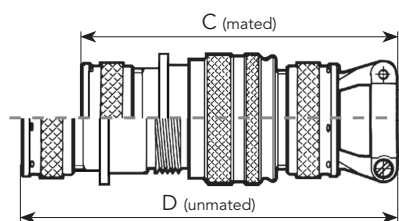

- Backnut - Type 31 or Type 01
- + Square flange receptacle
- + Plug
- + Straight cable clamp - Type 52 or Type 02

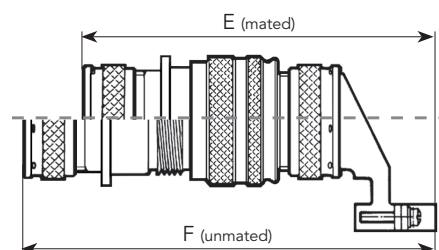

- Backnut - Type 31 or Type 01
- + Square flange receptacle + Plug
- + Elbow cable clamp - Type 51

Shell size	A	B	C		D		E	F
			Type 52	Type 02	Type 52	Type 02		
8	62	73	71.8	71.8	82.8	82.8	76.75	87.75
10			73.6	74.65	84.6	85.65	78.45	89.45
12			77	77.8	88	88.8	81.05	92.05
14			77	77.8	88	88.8	82.55	93.55
16			80	81	91	92	86.45	97.45

Shell size	A	B	C		D		E	F
			Type 52	Type 02	Type 52	Type 02		
18	62	73	87	87.35	98	98.35	87.85	98.85
20			89.6	90.8	100.6	101.8	89.4	100.4
22			93.5	93.7	104.5	104.7	91.05	102.05
24			95.9	96.9	106.9	107.9	92.65	103.65

Note: All dimensions are in millimeters (mm)

Description

- Stainless steel screw coupling connector designed for use in aviation engine harsh environments:
 - . high vibration resistant
 - . high temperature resistant (260° C)
 - . fire proof (1100° C)
- Scoop proof design to enable blind mating.
- Qualified to ESC11 standard, and per PrEN4067 standard project.
- Fully interchangeable and intermateable with ESC16 / 8536 connectors (integrated backshell version).
- Large array of crimp contact:
 - . standard size 16 and 20 contacts
 - . thermocouple size 16 and 20 contacts
- Fuel tank version available upon request.

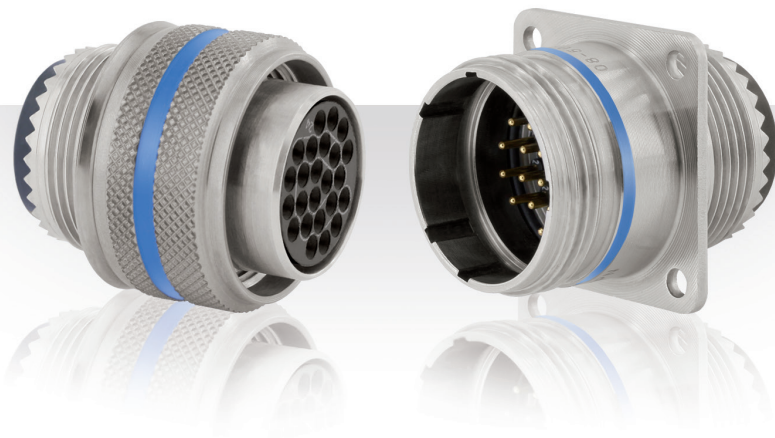

Technical features

Mechanical

- **Shell:**
 - . Passivated stainless steel.
- **Grommet and seal:**
 - . Silicone elastomer.
- **Insulator:**
 - . Thermoplastic.
- **Contact body:**
 - . Copper alloy.
- **Contact plating:**
 - . Gold over nickel.
- **Contact retention:**
 - . Size 20: 90 N
 - . Size 16: 110 N
- **Mating cycles:**
 - . 500 mating / unmating operations.
- **Vibration & shock:**
 - . According to JES290-083: 41 grms (2 x 8 hours)

Electrical

- **Dielectric withstanding:**

Altitude	Service I
Sea level	1500 Vrms
15 000 m	600 Vrms
21 000 m	400 Vrms
33 000 m	200 Vrms
- **Insulation Resistance:**
 - . 5000 MΩ under 500 Vdc.
- **Max current rating per contact:**

Contact size	20	16
Rating (A)	7.5	13
- **Contact resistance:**
 - . initial contact resistance at ambient temperature as per EN 2997 and EN315

Contact size	20	16	12
Resistance mΩ	7.3	3.8	3.5
- **Electrical continuity:**
 - . 5mΩ with RFI shielding (6SE class).
- **Shielding:**
 - . to 100 MHz at 1 GHz attenuation 65 dB.

Environmental

- **Temperature range:**
 - . - 65°C +260°C
- **Leakage:**
 - . as per 2591-312: Method B differential pressure: 100kPa
 - Maximum leakage flow: 16x10⁻⁶m³/h
- **Salt Spray:**
 - . 500 hours.
- **Fire resistance:**
 - . as per EN 2591-318: 6 min under a 1100°C flame without electrical perturbation, plus 14 min with no flame propagation (ES class).
- **Resistance to fluids:**
 - . MIL-H 5606 - SKYDROL 500 B4 - LD4 - JP5 - MIL-L 7870A - MIL-L 23699 - MIL- L 7808 - MIL-C 25769 - MIL-A 8243

Ordering information

SOURIAU part numbers

Basic Series	8534	6SE	14	15	S	N
Shell type:						
0SE: Stainless steel square flange receptacle						
6SE: Stainless steel plug with RFI screening ring						
6KE: Stainless steel plug without RFI screening ring						
Shell size: 14, 16, 18, 20, 22, 24						
Contact layout: See page 10						
Contact type:						
P: Pin A: Connector supplied less pin contact						
S: Socket B: Connector supplied less socket contact						
Orientation: N, 6, 7, 8, 9 (see page 26)						

ESC11 Qualified products

Basic Series	ESC11	SE	6	14	15	P	N	0
Shell class:								
KE: 260°C stainless steel: standard receptacle; plug without RFI screening ring								
SE: 260°C stainless steel: standard receptacle; plug with RFI screening ring								
Shell type:								
0: Square flange receptacle								
6: Plug								
Shell size: 14, 16, 18, 20, 22, 24								
Contact layout: See page 10								
Contact type:								
P: Pin								
S: Socket								
Orientation: N, 6, 7, 8, 9 (see page 26)								
Variant identifier:								
0: Delivered without contact								

Cross reference list

PrEN4067	SOURIAU	Short description
EN4067SE6●●●●B□	85346SE●●●●B□	Plug with RFI screening ring for socket contacts, delivered without contact
EN4067SE6●●●●F□	85346SE●●●●S□	Plug with RFI screening ring for socket contacts, delivered with contacts
EN4067SE6●●●●A□	85346SE●●●●A□	Plug with RFI screening ring for pin contacts, delivered without contact
EN4067SE6●●●●M□	85346SE●●●●P□	Plug with RFI screening ring for pin contacts, delivered with contacts
EN4067SE0●●●●B□	85340SE●●●●B□	Square flange receptacle for socket contacts, delivered without contact
EN4067SE0●●●●F□	85340SE●●●●S□	Square flange receptacle for socket contacts, delivered with contacts
EN4067SE0●●●●A□	85340SE●●●●A□	Square flange receptacle for pin contacts, delivered without contact
EN4067SE0●●●●M□	85340SE●●●●P□	Square flange receptacle for pin contacts, delivered with contacts
EN4067KE6●●●●B□	85346KE●●●●B□	Plug without RFI screening ring for socket contacts, delivered without contact
EN4067KE6●●●●F□	85346KE●●●●S□	Plug without RFI screening ring for socket contacts, delivered with contacts
EN4067KE6●●●●A□	85346KE●●●●A□	Plug without RFI screening ring for pin contacts, delivered without contact
EN4067KE6●●●●M□	85346KE●●●●P□	Plug without RFI screening ring for pin contacts, delivered with contacts

●●●● Shell size and contact layout □ Orientation

Dimensions

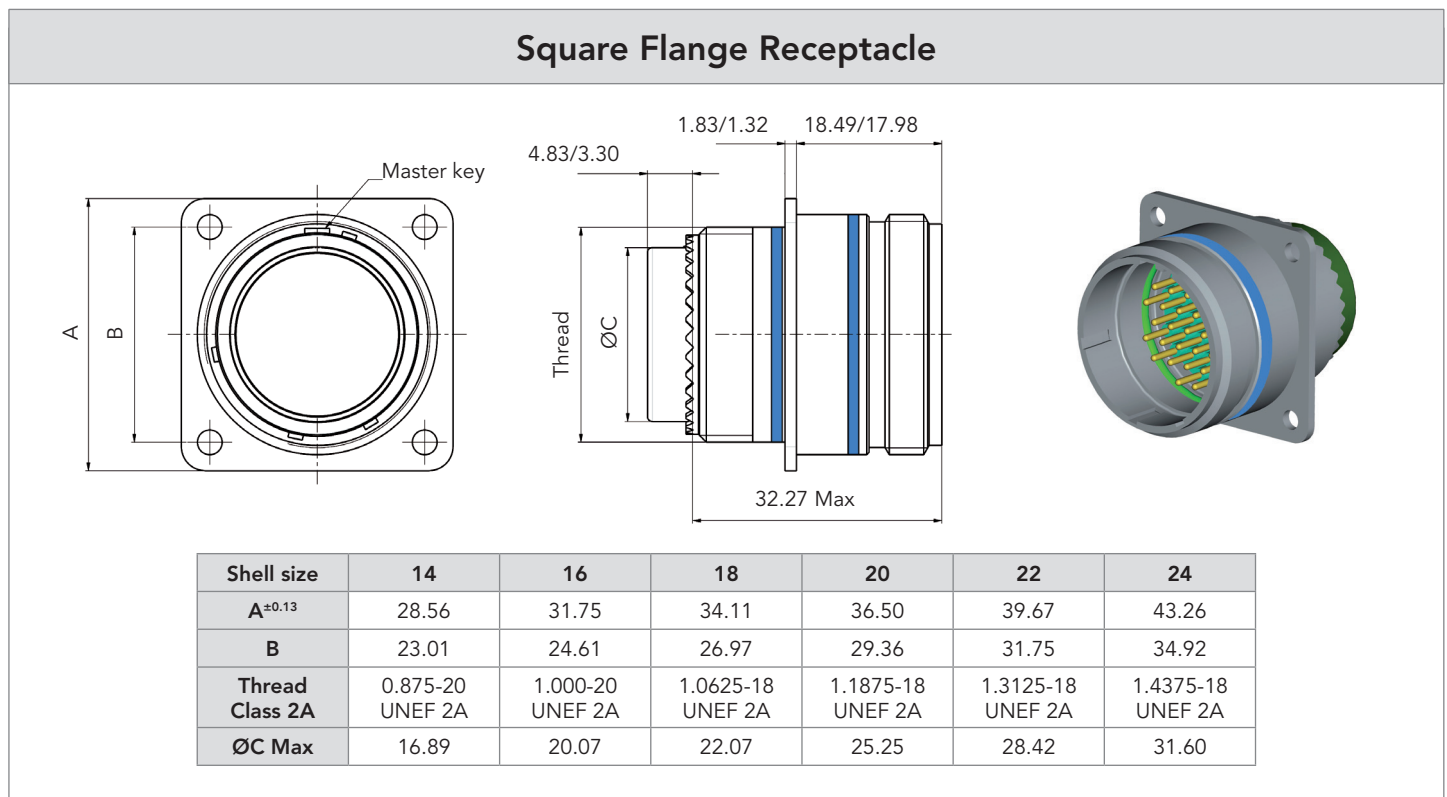
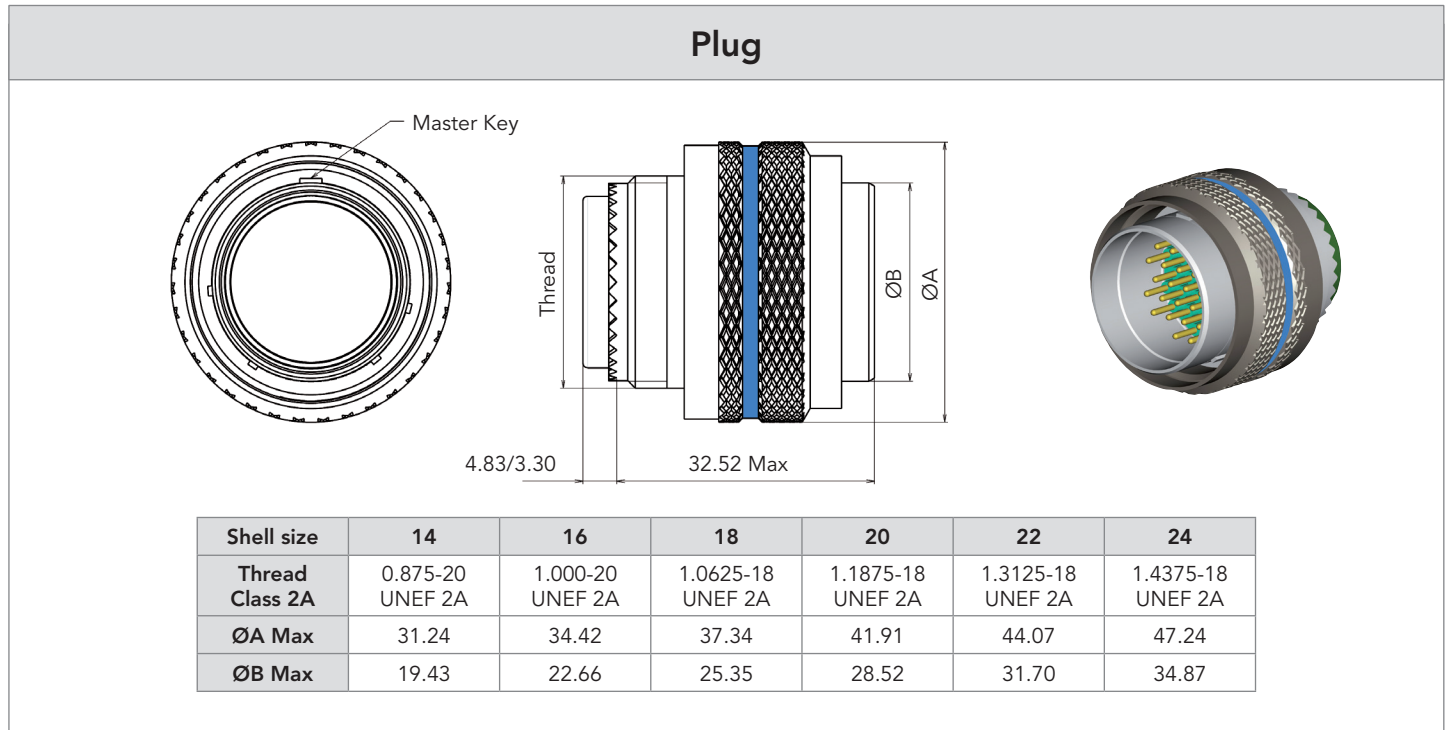

Note: All dimensions are in millimeters (mm)

Panel Cut Out

Square flange receptacle

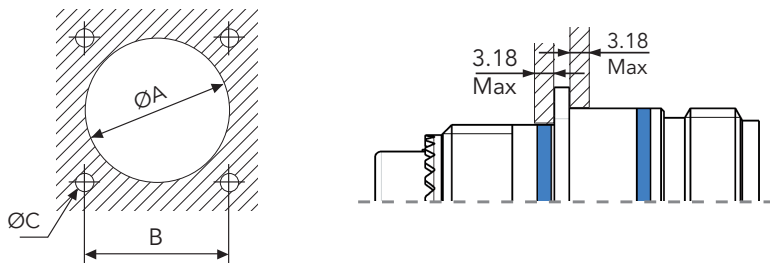

Shell size	A min	B	C
14	24.90	23.01	3.20
16	28.30	24.61	
18	31.10	26.97	
20	34.50	39.36	
22	37.50	31.75	3.80
24	40.60	34.92	

Minimum space between square flange receptacles: see page 20.

Orientation

Orientation

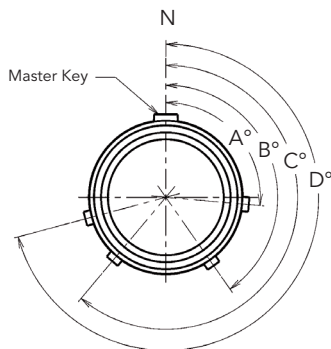

Front face view of plug

Shell size	Angles	N	6	7	8	9
14	A°	95	101	18	26	120
	B°	145	168	136	156	161
	C°	220	211	208	208	225
	D°	255	342	268	276	336
16	A°	95	101	18	-	-
	B°	145	168	136	-	-
	C°	220	211	208	-	-
	D°	255	342	268	-	-
18	A°	95	101	-	-	-
	B°	145	168	-	-	-
	C°	220	211	-	-	-
	D°	255	342	-	-	-
20, 22 & 24	A°	95	101	18	26	-
	B°	145	168	136	156	-
	C°	220	211	208	208	-
	D°	255	342	268	276	-

Connector weights

Mass max. (g) less contact			
Shell size	Plug with grounding spring	Plug without grounding spring	Receptacle Square flange
14	62	59	40
16	72	67	51
18	82	78	61
20	104	100	79
22	112	108	88
24	124	120	98

Mass of crimp contacts

Contact size	Mass (g)	
	Pin	Socket
20	0.24	0.29
16	0.53	0.59

Note: All dimensions are in millimeters (mm)

Description

- Stainless steel screw coupling connector designed for use in aviation engine harsh environments:
 - High vibration resistance
 - High temperature resistance 200°C / 260°C
 - Fire proof 1100°C
- Integrated backshell for compact and light weight applications, with the possibility to have a full scoop proof connection (8536 Series / ESC16 Series).
- Qualified to ESC15 (8535 Series) and ESC16 (8536 Series) standard, and per the new EN2997 issue.
- Fully interchangeable:
 - 8535 Series with BACC 63 CM-CN, EN2997 & ESC10 connectors
 - 8536 Series with ESC11 connectors
- 8535 Series intermateable with BACC 63 CM-CN
- Large array of crimp contacts: (same as for 8533 Series)
 - Standard size 12, 16 and 20 contacts
 - Thermocouple size 12, 16 and 20 contacts



Technical features

Mechanical

- **Shell:** Passivated stainless steel.
- **Grommet and seal:** Silicone elastomer.
- **Insulator:** Thermoplastic.
- **Contact body:** Copper Alloy.
- **Contact plating:** Gold Over Nickel.
- **Contact retention:**
 - . Size 20: 90 N
 - . Size 16: 110 N
 - . Size 12: 130 N
- **Mating cycles:** 500 coupling operation.
- **Vibration & shock:**
 - . According to JES290-083: 41 grms, 2x 8 hours (ES class)
 - . According to JES290-102: 35 grms, 60 hours (KV class)
 - . According to EN2591: 5Hz to 2000Hz at 1G²/Hz (2x8 hours)

Electrical

- **Dielectric withstanding:**

Altitude	Service
Alt ground	1500 Vrms
15 000 m	600 Vrms
21 000 m	400 Vrms
33 000 m	200 Vrms
- **Insulation Resistance:** 5000 MΩ at 500 Vdc.
- **Max current rating per contact:**
 - . Size 20: 7.5 A
 - . Size 16: 13 A
 - . Size 12: 23 A
- **Contact resistance:**
 - . initial contact resistance at ambient temperature as per EN 2997 and EN315

Contact size	20	16	12
Resistance mΩ	7.3	3.8	3.5
- **Electrical continuity:** 5mΩ with RFI shielding.
- **Shielding:** to 100 MHz at 1 GHz attenuation 65 dB.

Environmental

- **Temperature range:** - 60°C +260°C
- **Leakage as per 2591-312:**
 - Method B differential pressure: 100kPa
 - Maximum leakage flow: 16x10⁻⁶ m³/h
- **Salt Spray:** 500 hours.
- **Fire resistance as per EN 2591-318:**
 - 6 min under a 1100°C flame without electrical perturbation, plus 14 min with no flame propagation (ES class).
- **Resistance to fluids:**
 - MIL-H 5606 - SKYDROL 500 B4 - LD4 - JP5 - MIL-L 7870A - MIL-L 23699 - MIL- L 7808 - MIL-C 25769 - MIL-A 8243

Ordering information

SOURIAU 8535 part numbers

Basic Series: ESC15 / EN2997 type	8535	3ES	18	14	S	N
Class & Shell type:						
Integrated backshell stainless steel shell with knurl type 1: (see p.30 for knurl description)						
AES: 260°C square flange receptacle						
CES: 260°C plug with RFI screening ring						
DES: 260°C square flange receptacle with clinch nut*						
EES: 260°C plug without RFI screening ring						
OKS: 200°C square flange receptacle						
OKV: 260°C square flange receptacle, high vibration						
3KS: 200°C plug with RFI screening ring						
3KV: 260°C plug with RFI screening ring, high vibration						
4KV: 260°C plug without RFI screening ring, high vibration						
5KS: 200°C square flange receptacle with clinch nut*						
5KV: 260°C square flange receptacle with clinch nut, high vibration						
Integrated backshell stainless steel shell with knurl type 2: (see p.30 for knurl description)						
0ES: 260°C square flange receptacle						
3ES: 260°C plug with RFI screening ring						
4ES: 260°C plug without RFI screening ring						
5ES: 260°C square flange receptacle with clinch nut*						
Shell size: See pages 10 to 13						
Contact layout: See pages 10 to 13						
Contact type:						
P: Pin						
S: Socket						
Orientation:						
N, 6, 7, 8, 9 (see page 32)						
Specification:						
empty: Delivered with contacts						
L: Delivered without contacts						

Note: aluminum version, please consult us.

* Please consult us.

SOURIAU 8536 part numbers

Basic Series: ESC16 scoop proof type	8536	3ES	18	14	S	N
Class & Shell type:						
Integrated backshell stainless steel shell with knurl type 1: (see p.30 for knurl description)						
4KV: 260°C plug without RFI screening ring, high vibration						
5KV: 260°C square flange receptacle with clinch nut, high vibration						
Integrated backshell stainless steel shell with knurl type 2: (see p.30 for knurl description)						
0ES: 260°C square flange receptacle						
3ES: 260°C plug with RFI screening ring						
4ES: 260°C plug without RFI screening ring						
Shell size: See pages 10 to 13						
Contact layout: See pages 10 to 13						
Contact type:						
P: Pin						
S: Socket						
Orientation:						
N, 6, 7, 8, 9 (see page 32)						
Specification:						
empty: Delivered with contacts						
L: Delivered without contacts						

ESC15/ESC16 Qualified product

Basic Series	ESC15	KE2	18	14	S	N	0
<p>ESC15: Integrated backshell ESC16: Integrated backshell, scoop proof version</p>							
<p>Class & Shell type: Integrated backshell stainless steel shell with knurl type 1: (see p.30 for knurl description) KV2: 260°C square flange receptacle, high vibration* KV4: 260°C square flange receptacle with clinch nut, high vibration KV7: 260°C plug without RFI screening ring, high vibration Integrated backshell stainless steel shell with knurl type 2: (see p.30 for knurl description) KE2: 260°C square flange receptacle KE7: 260°C plug without RFI screening ring SE7: 260°C plug with RFI screening ring KE4: 260°C square flange receptacle with clinch nut</p>							
<p>Shell size: See pages 10 to 13</p>							
<p>Contact layout: See pages 10 to 13</p>							
<p>Contact type: P: Pin S: Socket</p>							
<p>Orientation: N, 6, 7, 8, 9 (see page 32)</p>							
<p>Mandatory variant identifier: 0: Delivered without contact (class KE & SE only) V: Delivered without contact (class KV only)</p>							

* Please consult us.

EN2997 Qualified product

Basic Series	EN2997	SEA	18	14	F	N
<p>Class & Shell type: Integrated backshell stainless steel shell with knurl type 1: (see p.30 for knurl description) KEC: 260°C plug without RFI screening ring KVC: 260°C plug without RFI screening ring, high vibration SC: 200°C plug with RFI screening ring SEC: 260°C plug with RFI screening ring SVC: 260°C plug with RFI screening ring, high vibration* SA: 200°C square flange receptacle SEA: 260°C square flange receptacle SVA: 260°C square flange receptacle, high vibration* SD: 200°C square flange receptacle with clinch nut* SED: 260°C square flange receptacle with clinch nut* SVD: 260°C square flange receptacle with clinch nut, high vibration* Integrated backshell aluminum shell with knurl type 1: (see p.30 for knurl description) WSC: 175°C olive-green cadmium plug with RFI screening ring, conductive plating* RSC: 200°C nickel plug with RFI screening ring, conductive plating* WSA: 175°C olive-green cadmium square flange receptacle, conductive plating* RSA: 200°C nickel square flange receptacle, conductive plating*</p>						
<p>Shell size: See pages 10 to 13</p>						
<p>Contact layout: See pages 10 to 13</p>						
<p>Contact type: M: Male contact A: Connector delivered without male contact F: Female contact B: Connector delivered without female contact</p>						
<p>Orientation: N, 6, 7, 8, 9 (see page 32)</p>						

* Please consult us.

Knurl description

Knurl Type 1

- Conform to:
- EN2997
 - ESC15/ESC16
- High vibration

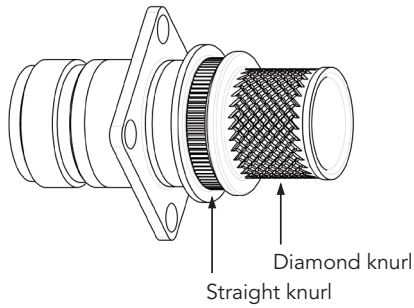

Knurl Type 2

- Conform to:
- ESC15/ESC16

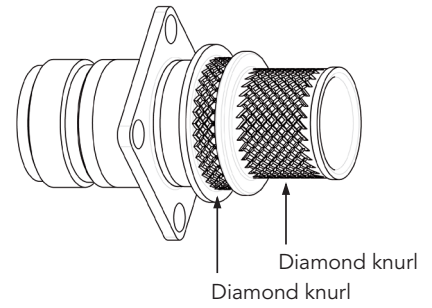

Dimensions

Plug - 8535/ESC15/EN2997 model 8536/ESC16

Front face view

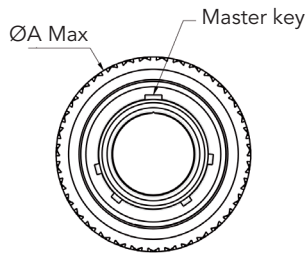

8535/ESC15/EN2997C

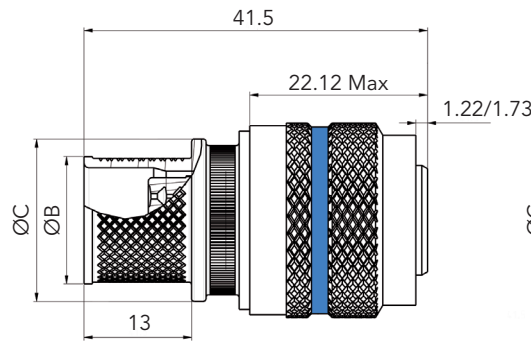

8536/ESC16

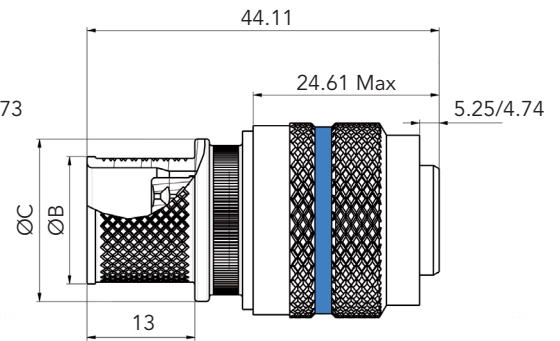

Shell size	08	10	12	14	16	18	20	22	24	28
ØA Max	21.30	24.89	29.59	31.24	34.42	37.34	41.91	44.07	47.24	55.24
ØB ^{±0.1}	12.10	15.32	18.27	21.45	24.62	26.04	29.22	32.40	35.47	41.92
ØC ^{±0.1}	18.70	19.60	22.00	26.10	28.60	29.80	33.60	36.70	42.10	46.60

Tolerance on linear dimensions shall be ±0.25 unless otherwise specified.

Square Flange Receptacle - 8535/ESC15/EN2997 model 8536/ESC16

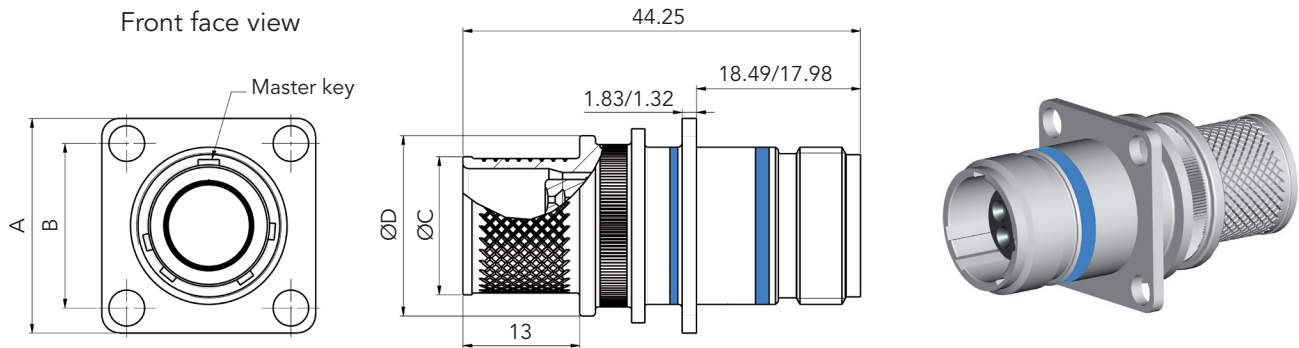

Shell size	08	10	12	14	16	18	20	22	24	28
A ^{±0.13}	20.62	23.80	26.19	28.57	31.75	34.11	36.50	39.67	43.26	50.80
B	15.09	18.26	20.62	23.01	24.61	26.97	29.36	31.75	34.92	39.67
ØC ^{±0.1}	12.10	15.32	18.27	21.45	24.62	26.04	29.22	32.40	35.57	41.92
ØD ^{±0.1}	18.70	19.60	22.00	26.10	28.60	29.80	33.60	36.70	42.10	46.60

Tolerance on linear dimensions shall be ±0.25 unless otherwise specified.

Square Flange Receptacle With Clinch Nut - 8535/ESC15/EN2997 model 8536/ESC16

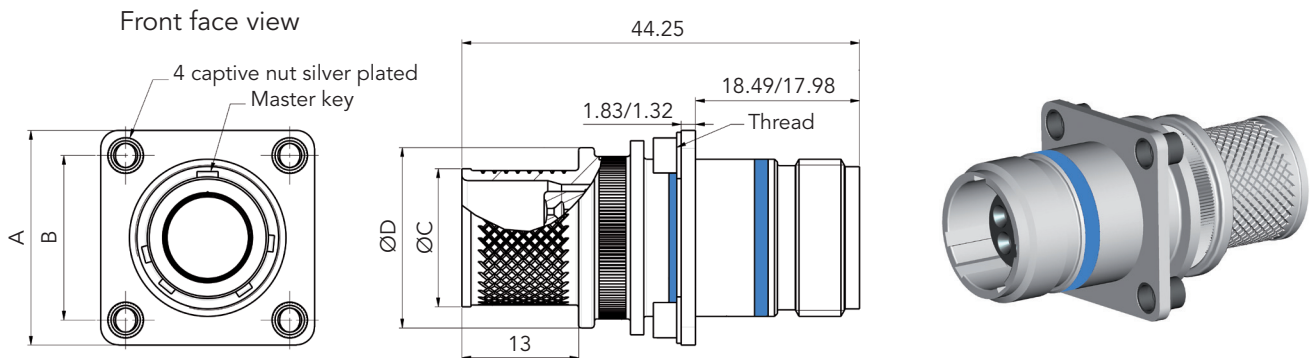

Shell size	08	10	12	14	16	18	20	22	24	28
A ^{±0.13}	20.62	23.80	26.19	28.57	31.75	34.11	36.50	39.67	43.26	50.80
B	15.09	18.26	20.62	23.01	24.61	26.97	29.36	31.75	34.92	39.67
ØC ^{±0.1}	12.10	15.32	18.27	21.45	24.62	26.04	29.22	32.40	35.57	41.92
ØD ^{±0.1}	18.70	19.60	22.00	26.10	28.60	29.80	33.60	36.70	42.10	46.60
Thread BS1580 Class 3B	0.1120-40UNC								0.1380-32UNC	

Tolerance on linear dimensions shall be ±0.25 unless otherwise specified.

Note: All dimensions are in millimeters (mm). Knurl design vary according to norm.

Panel Cut Out (Receptacle Shell Type 0 and 5)

Square flange receptacle

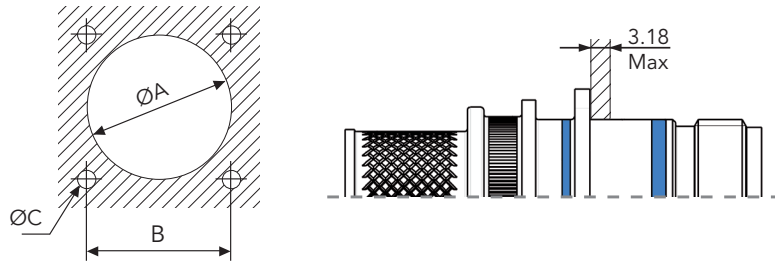

Shell size	A min	B	C
08	15.80	15.09	3.20
10	18.70	18.26	
12	23.40	20.62	
14	24.90	23.01	
16	28.30	24.61	
18	31.10	26.97	
20	34.50	39.36	
22	37.50	31.75	3.80
24	40.60	34.92	
28	48.00	39.67	

Minimum space between square flange receptacles: see page 20.

Orientation

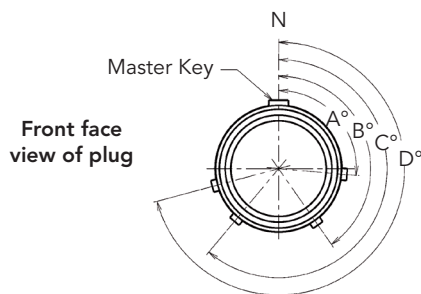

8535/ESC15 / EN2997

Shell size	Angles	N	6	7	8	9
08 & 10	A°	105	102	80	35	64
	B°	140	132	118	140	155
	C°	215	248	230	205	234
	D°	265	320	312	275	304
12 to 28	A°	105	18	92	84	24
	B°	140	149	152	152	135
	C°	215	192	222	204	199
	D°	265	259	342	334	240

8536/ESC16

Shell size	Angles	N	6	7	8	9
08 & 10	A°	95	40	48	85	56
	B°	145	112	130	155	126
	C°	220	228	242	220	205
	D°	255	258	280	325	296
12 to 28	A°	95	101	18	26	120
	B°	145	168	138	156	161
	C°	220	211	208	208	225
	D°	255	342	268	276	336

Connector weights

Shell size	Mass max. (g) less contact	
	Square flange	Plug
	Stainless steel	Stainless steel
8	25	45
10	40	62
12	48	71
14	60	85
16	70	100
18	81	113
20	89	125
22	101	141
24	110	157
28	135	192

Mass of crimp contacts

Contact size	Mass (g)	
	Pin	Socket
20	0.24	0.29
16	0.53	0.59
12	1.15	1.28

Note: All dimensions are in millimeters (mm)

Description

- The utmost solution to combine high vibrations, high temperatures and high power supply: up to 80 Amps continuous rating at 260°C ambient temperature with a 20% space-savings compared with other solutions.
- Two contact sizes - size 6 and size 4 - as well as the ability to use quadrax contacts in size 6 cavity layouts.
- Standard strain relief backshell or spacer accessory to adapt any specific backshell.
- Airbus ABS 1340-1343, 1426-1427, 1452 qualified.
- Grounded insert option for optimized quadrax performance.
- Electro mechanical actuator power supply, alternator, starter applications.



Technical features

Mechanical

- **Shell:**
 - . nickel plated aluminum (R class),
 - . passivated stainless steel (E & K classes).
- **Grommet and seal:**
 - . silicone elastomer.
- **Insulator:**
 - . thermoplastic.
- **Contact body:**
 - . copper alloy.
- **Contact plating:**
 - . gold over nickel.
- **Contact retention:**
 - . size 4: 200N . size 8: 130N
 - . size 6: 156N
- **Endurance:**
 - . 500 mating cycles (E & K classes),
 - . 250 mating cycles (R class).
- **Vibration & shock:**
 - . according to EN 2997.

Electrical

- **Dielectric withstanding:**

Altitude	Service I
Sea level	1500 Vrms
15 000 m	600 Vrms
21 000 m	400 Vrms
33 000 m	200 Vrms
- **Insulation resistance:**
 - . 5000 MΩ under 500 Vdc.
- **Max current rating per contact:**
 - Quadrax: 4 size 24 inner contacts in a size 8 outer contact.

Contact size	6	4
Rating (A)	60	80
- **Contact resistance:**
 - . Initial < 0.4 mΩ.
- **Electrical continuity:**
 - . 5mΩ with RFI shielding.
- **Shielding:**
 - . to 100 MHz at 1 GHz attenuation 65 dB.

Environmental

- **Temperature range:**
 - . -60°C +200°C R & K classes,
 - . -60°C +260°C E class & #6 contact only.
- **Leakage:**
 - . as per 2591-312:
 - Method B differential pressure: 100kPa
 - Maximum leakage flow: 16x10⁻⁶ m³/h
- **Salt spray:**
 - . 48 hours (R class),
 - . 500 hours (E & K classes).
- **Fire resistance:**
 - . as per EN 2591-318:
 - 6 min under a 1100°C flame without electrical perturbation, plus 14 min with no flame propagation (ES class).
- **Resistance to fluids:**
 - . MIL-H 5606 - SKYDROL 500 B4 - LD4 - JP5 - MIL-L 7870A - MIL-L 23699 - MIL- L 7808 - MIL-C 25769 - MIL-A 8243

Ordering information

SOURIAU part numbers

Basic series	8533	0	R	S	20	04	P	N	G	L
Shell type:										
0: Square flange receptacle										
3: Plug with RFI shielding										
7: Jam nut receptacle										
Shell class:										
R: Nickel plated aluminum shell (200°C)										
K: Stainless steel shell (200°C)										
E: Stainless steel shell (260°C - except layouts 08-01 & 24-04: 200°C)										
S: With 360° teeth										
Shell size:										
08, 18, 20, 24, 28										
Contact layout:										
See page 10										
Contact type:										
P: Pin										
S: Socket										
Orientation:										
N, 6, 7, 8, 9, Y (see page 20)										
Insert class:										
None: Not grounded										
G: Grounded - for Quadrax applications only										
Mandatory suffix for shells sizes 18, 20, 24 & 28 :										
109: With contact #4 for cable #6 + sealing boot										
115: With contact #4 for cable #8 + sealing boot										
125: With quadrax contact + sealing boot (200°C max)										
126: With backshell, without contact and sealing boot										
136: With contact #6 for cable #6 + sealing boot										
138: With contact #6 for cable #8 + sealing boot										
143: With contact #6 for cable #10/12 + sealing boot										
231: With spacer, without contact and sealing boot (see next page for available layouts)										
L: Without contact and sealing boot										
Mandatory suffix for layout 08-01 only (200°C, plug with female contact & receptacle with male contact only):										
165: With quadrax contact + backshell for heatshrink sleeving										
L165: Without quadrax contact, with backshell for heatshrink sleeving										

Strain relief backshell

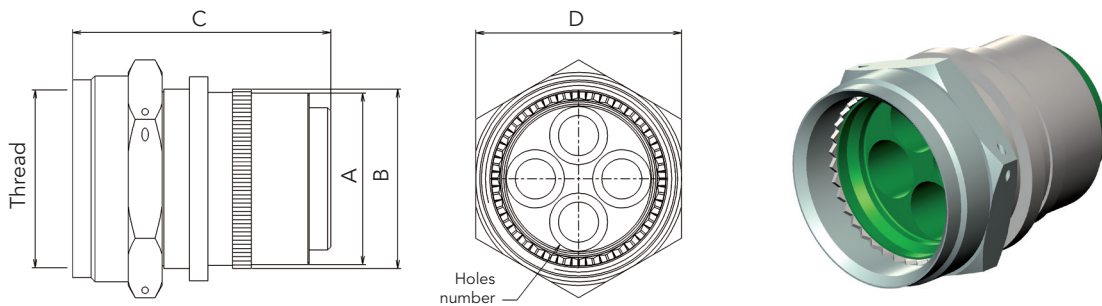

Layout	Material	Part number	Mass max (g)	A ^{±0.1}	B Max	C ^{±0.12}	D	Holes number	Thread Class 2B	Coupling torque N.m ^{±0.5}
18-02	Aluminum	85338342	40	24.90	29.45	41.78 ^{±1.2}	31.62	2	1.0625-18 UNEF	4.5
	Stainless steel	85338343	75							
20-04	Aluminum	85338250	40	27.72	30.12	41.78 ^{±1.2}	33.21	4	1.1875-18 UNEF	9
	Stainless steel	85338281	73							
24-04	Aluminum	85338223	53	33.71	37.26	48.95 Max	45	4	1.4375-18 UNEF	9
	Stainless steel	Consult us	-							
28-06	Aluminum	85338245	82	39.7	44.4	41.78	47.49	6	1.7500-18 UNS	10
	Stainless steel	85338288	146							

Spacer

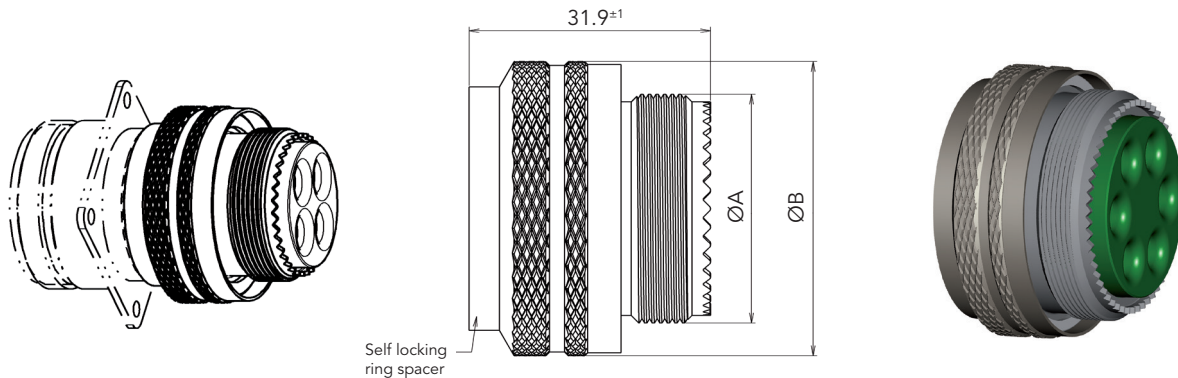

Layout	Stainless steel		Aluminum		ØA	ØB Max
	Part number	Mass max (g)	Part number	Mass max (g)		
20-04	8533-8388	88	8533-8387	Consult us	1"3/16-18 UNEF 2A	40
24-04	8533-8390	115	8533-8389		1"7/16-18 UNEF 2A	45
28-06	8533-8392	140	8533-8391		1"3/4-18 UNS	53

Note: All dimensions are in millimeters (mm)

Description

- Screw coupling connector
- EN2997 and ESC10 qualified connector
- High temperature and high vibration resistance
- Glass sealed hermetic:
 - . high hermeticity performance
 - . compact low profile
- Various mounting styles:
 - . compact solder mount receptacle
 - . easy to install square flange receptacle
 - . easy to replace jam nut receptacle
- Fully interchangeable with MIL 83723 hermetic connectors
- Special fuel tank versions
- 230V qualified versions where higher voltage is used to reduce cable weight

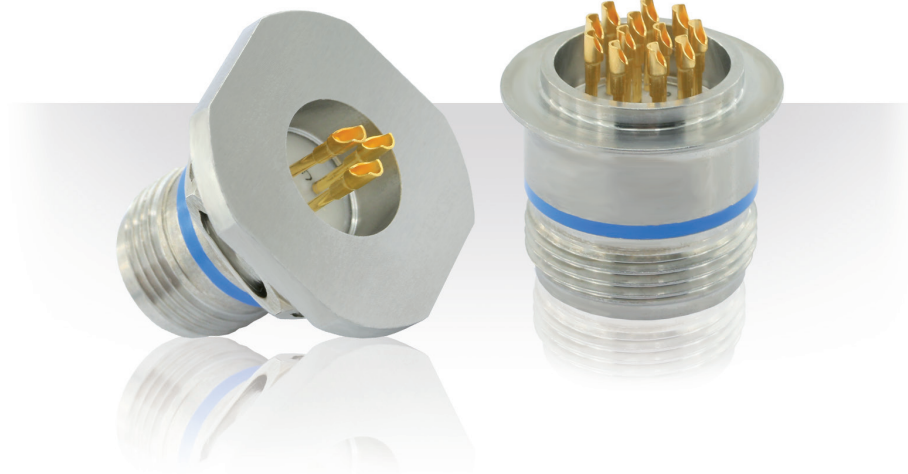

Technical features

Mechanical

- **Shell:**
 - . Passivated Stainless steel
- **Seals:**
 - . Silicone elastomer
- **Contact:**
 - . Ferrous alloy
- **Contact plating:**
 - . Gold
- **Shock:**
 - . 300 m/s² (30g) during 3 ms
- **Endurance:**
 - . 500 mating/unmating operations
- **Vibration:**
 - . Random 5 Hz to 2000 Hz at 1G²/Hz (2 x 8 hours)

Electrical

- **Max current rating per contact:**

Contact size	20	16	12	6	4
Rating (A)	5	10	17	46	60

- **Dielectric withstanding voltage:**

Altitude	Service I
Sea level	1500 Vrms
15 000 m	600 Vrms
21 000 m	400 Vrms
33 000 m	200 Vrms

- **Contact resistance at rated current:**
 - . Maximum initial contact resistance at ambient temperature

Contact size	20	16	12	6	4
Resistance mΩ	12	8.5	5	2	2

Environmental

- **Operating temperature:**
 - . Class Y : -65°C to 200°C
 - . Class YE : -65°C to 260°C cyclic
- **Hermeticity:**
 - . Leak rate <10⁻⁷ atm.cm³/s (helium gas test)
- **Damp heat:**
 - . As per EN 2997 and NFL 54143: 10 cycles of 24h
- **Salt spray:**
 - . 500 hours
- **Resistance to fluids:**
 - . MIL-H 5606 - SKYDROL 500 B4 - LD4 - JP5 - MIL-L 7870A - MIL-L 23699 - MIL- L 7808 - MIL-C 25769 - MIL-A 8243
- **Fuel immersion version:**
 - . 105°C max
 - . As per PrEN3645

Ordering information

SOURIAU part numbers

Basic series	8533	1	Y	10	05	P	N	-
Shell type:								
1: Solder mount receptacle								
2: Square flange receptacle								
7: Jam nut receptacle								
Class:								
Y: 200°C								
YE: 260°C								
Shell size: 08 - 10 - 12 - 14 - 16 - 18 - 20 - 22								
Contact layout: See page 10								
Contact type:								
P: Pin								
Orientation: N - 6 - 7 - 8 - 9 - T - V - Y (see page 41)								
Specification (other specification: see page 40):								
None: Standard hermetic version (solder cup) - except for layout 20-04								
112: Standard hermetic version (solder cup) - for layout 20-04 only								
22: Hermetic fuel tank version (solder cup)								
600: 230V qualified connector, delivered with contacts (layouts 12-03, 14-04, 14-07 & 20-04 - orientation T & V)								

EN2997 qualified products

Basic series	EN 2997	Y	0	08	03	M	N
Class:							
Y: 200°C							
YE: 260°C							
Shell type:							
0: Square flange receptacle							
1: Solder mount receptable							
7: Jam nut receptable							
Shell size: 08 - 10 - 12 - 14 - 16 - 18 - 20 - 22							
Contact layout: See page 10							
Contact type:							
M: Pin							
Orientation: N - 6 - 7 - 8 - 9 - Y (see page 41)							

ESC10 qualified products

Basic series	ESC 10	YE	1	08	03	P	N	0
Class:								
YE: 260°C								
Shell type:								
1: Solder mount receptacle								
2: Square flange receptacle								
3: Jam nut receptable								
Shell size: 08 - 10 - 12 - 14 - 16 - 18 - 20 - 22								
Contact layout: See page 10								
Contact type:								
P: Pin								
Orientation: N - 6 - 7 - 8 - 9 - Y (see page 41)								
0: variant identifier								

Dimensions

Solder mount hermetic receptacle (Class Y & YE)

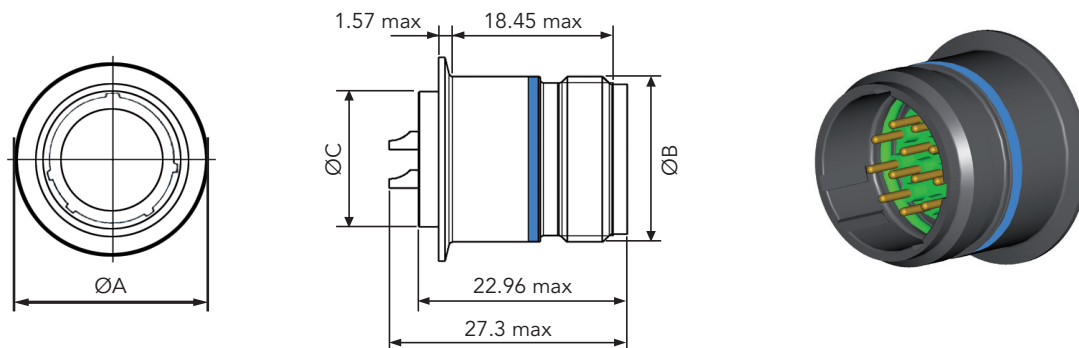

Shell size	8	10	12	14	16	18	20	22	24
ØA Max	18.36	21.59	26.80	27.94	30.99	34.39	37.34	40.64	43.68
ØB Max	14.29	17.46	22.22	23.81	26.99	30.16	33.34	36.51	39.69
ØC Max	12.70	14.27	19.05	20.62	23.80	26.97	30.15	33.32	36.50

Jam nut hermetic receptacle (Class Y & YE)

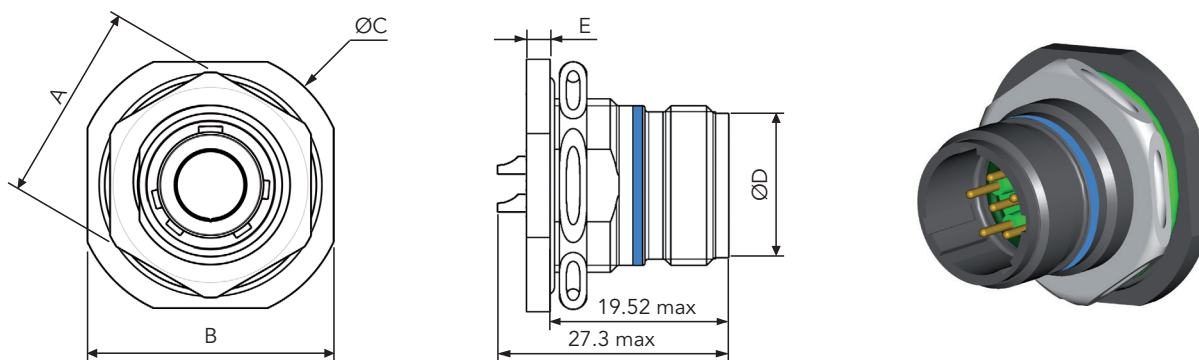

Shell size	8	10	12	14	16	18	20	22	24
A Max	21.06	24.23	29.01	30.61	33.76	36.96	40.11	43.31	46.46
B Max	24.89	28.04	32.79	35.33	38.51	41.68	44.86	49.63	52.81
ØC Max	27.38	30.28	35.05	38.51	41.68	44.86	49.63	52.78	55.42
ØD Max	14.29	17.46	22.22	23.81	26.99	30.16	33.34	36.51	39.69
E Max	3.48							3.76	
Tightening torque of attachment nut Torque in N.m ^{±10%}	7	10	12	15	18	22	25	27	29

Note: All dimensions are in millimeters (mm)

Dimensions

Square flange hermetic receptacle (Class Y & YE)

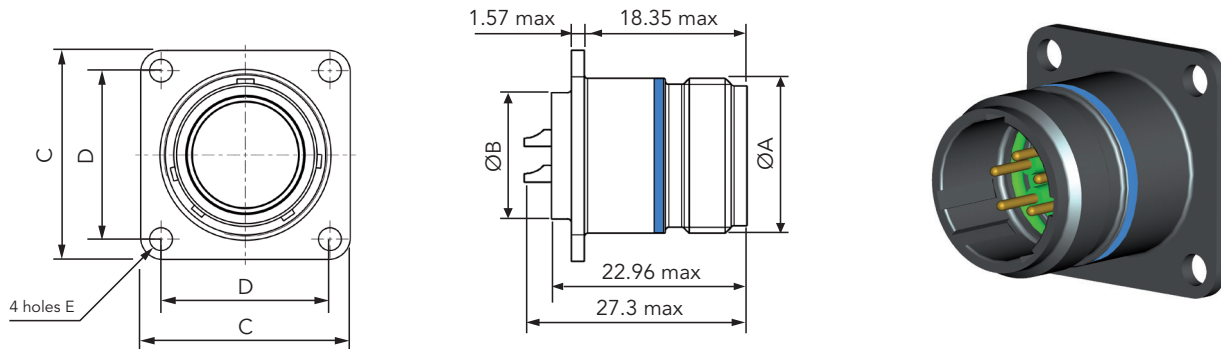

Shell size	8	10	12	14	16	18	20	22	24
Ø A Max	14.27	17.67	22.22	23.77	26.97	30.15	33.32	36.49	39.67
Ø B Max	12.70	14.27	19.05	20.62	23.80	26.97	30.15	33.82	36.50
C Max	20.75	23.93	26.32	28.71	31.88	34.24	36.63	39.80	43.36
D	15.09	18.26	20.62	23.01	24.61	26.97	29.36	31.75	34.92
E Max	3.30								3.91

Panel cut out

Type 1
Solder mount receptacle

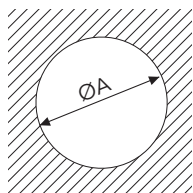

Type 2
Square flange receptacle

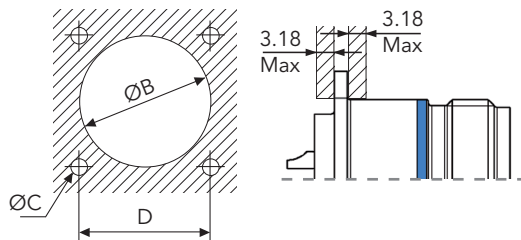

Type 7
Jam nut receptacle

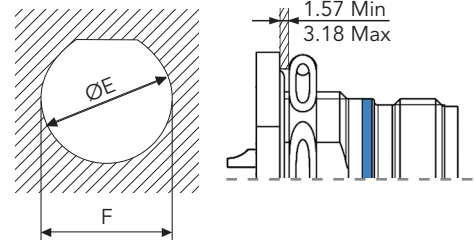

Shell size	8	10	12	14	16	18	20	22	24	28
ØA Min	12.96	14.53	19.30	20.88	24.05	27.23	30.40	33.58	36.75	-
B min	15.8	18.7	23.4	24.9	28.3	31.1	34.5	37.5	40.6	48
C	3.2								3.8	
D	15.09	18.26	20.62	23.01	24.61	26.97	39.36	31.75	34.92	39.67
E	16.00	19.17	23.92	25.52	28.70	31.87	35.05	38.22	41.40	-
F	15.24	18.41	23.16	24.76	27.94	30.99	34.16	37.33	40.51	-

Note: All dimensions are in millimeters (mm)

Contact variations

Contact variations summary

Contact variations

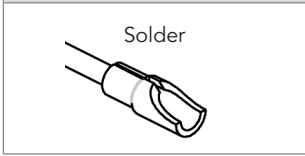

Solder

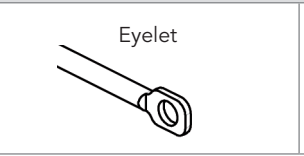

Eyelet

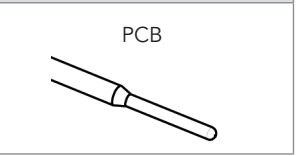

PCB

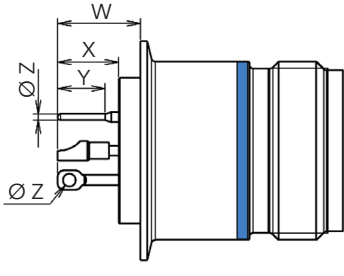

Type 1: Solder mount receptacle

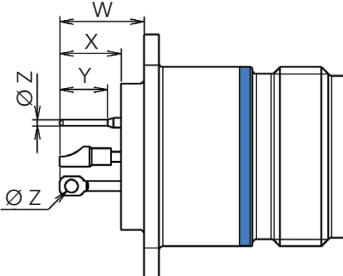

Type 2: Square flange receptacle

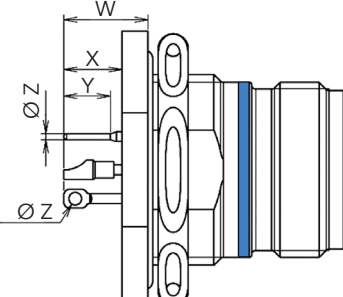

Type 7: Jam nut receptacle

Type of contact	Specification	Contact size	W Max	X Min	Y Min	Ø Z Max	Designation
PCB contacts	05	20	8.78	4.78	4.50	0.65	PCB contact
	118	20	10.88	6.88	6.25	0.65	Long PCB contact
Eyelet contacts	105	20	6.98	2.98	4.05 ^{+0.2}	1.25 _{0.15} ⁰	Eyelet contact
Solder cup contacts	Without specification or specification 22	20-16-12	7.78	2.98	-	-	Standard Solder cup contact
	112	6	9.03	5.13	-	-	
	62	20-16-12	7.78	2.98	-	-	Solder cup contact tin plated on rear part

Note: for other contact length, please consult us.

Orientation

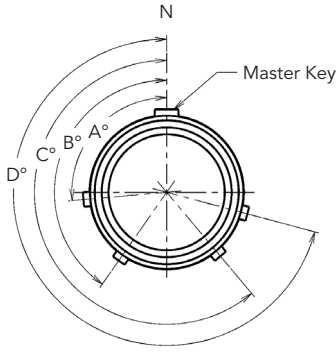
Orientation										
 <p>Front face view of receptacle</p>	Shell size	Angles	N	6	7	8	9	T	V	Y
	08	A°	105	102	80	35	64	-	-	-
		B°	140	132	118	140	155	-	-	-
		C°	215	248	230	205	234	-	-	-
		D°	265	320	312	275	304	-	-	-
10	A°	105	102	80	35	64	-	-	25	
	B°	140	132	118	140	155	-	-	115	
	C°	215	248	230	205	234	-	-	220	
	D°	265	320	312	275	304	-	-	270	
12 & 14	A°	105	18	92	84	24	55	50	98	
	B°	140	149	152	152	135	145	156	152	
	C°	215	192	222	204	199	228	218	268	
	D°	265	259	342	334	240	280	290	338	
20	A°	105	18	92	84	24	45	60	98	
	B°	140	149	152	152	135	160	165	152	
	C°	215	192	222	204	199	210	235	268	
	D°	265	259	342	334	240	300	285	338	
16, 18, 22 & 24	A°	105	18	92	84	24	-	-	98	
	B°	140	149	152	152	135	-	-	152	
	C°	215	192	222	204	199	-	-	268	
	D°	265	259	342	334	240	-	-	338	

Connector weights (in grams)

Shell size	Square flange receptacle	Jam nut receptacle	Solder mount receptacle
08	18	29	15
10	24	37	21
12	31	50	31
14	40	58	35
16	49	72	46
18	54	79	51
20	62	87	59
22	77	108	73
24	88	122	86

Cross reference list

SOURIAU	MIL 83723
85332Y •••• P □	M83723/88Y •••• □
85337Y •••• P □	M83723/89Y •••• □
85331Y •••• P □	M83723/90Y •••• □

•••• Shell size & layout □ Orientation

853 SERIES

Common Section

■ Crimp contacts	44
■ Thermocouple contacts	46
■ Contact ordering information	47
■ #8 Quadrax contacts	48
■ Sealing boots	48
■ Filler plugs	48
■ Wiring instruction	49
■ Insertion and extraction tools	50
■ Crimping tools	50
■ Tightening support & tool	51
■ Silicone gaskets	51
■ Grounding ring replacement kit	51
■ Protective caps	51
■ Dummy receptacle	52
■ Coordinates information	52

Introduction

- **SOURIAU's** fire wall contacts offer covers a wide range of performances within the scope of high temperatures and high vibrations constraints.
- Each type has been qualified and validated by either major qualification organizations or major aerospace manufacturers:
 - Size 12, 16 & 20 signal contacts: EN3155 and ESC30 qualified
 - Size 12, 16 & 20 thermocouple contacts: EN3155 and ESC30 qualified
- **SOURIAU** also provides any tool or accessory necessary for harnessing (crimping tool, insertion and extraction tool,...) or for test benches (dummy receptacles,...)

Signal & power contacts

Crimp contacts 175°C and 200°C

Contact size	Type	Part numbers		Code	Admissible wire section		External Ø over insulator		Mass g (±15%)	
		Pin	Socket		Color bands	AWG	mm²	Min.	Max.	Pin
20	Standard	8526-1348	8526-1344 900	Red/red	24-20	0.25-0.60	0.85	2.10	0.24	0.29
	Small barrel	8525-7256 900	8525-7750 900	Red/green	22-26	0.15-0.40	0.85	2.10	0.24	0.29
	Large barrel	8522-2349 A	8520-292	Red/brown	24-18	0.25-1	0.85	2.10	0.24	0.29
16	Standard	8526-1349	8526-1346A 900	Blue/blue	20-16	0.60-1.20	1.20	2.70	0.53	0.59
	Small barrel	8526-4175	8526-4176	Blue/brown	24-18	0.25-1	1.20	2.70	0.53	0.59
	Large barrel	8522-6179 A	8522-6180B 900	Blue/white	18-14	1-2	1.20	2.70	0.53	0.59
12	Standard	8526-1350	8526-1347A 900	Yellow/yellow	16-12	1.20-3	1.90	4.01	1.15	1.28
	Small barrel	8526-5041	8526-5591A 900	Yellow/brown	24-18	0.25-1	1.90	4.01	1.15	1.28
	Large barrel	8526-4136 900	8526-4138A 900	Yellow/brown		3-4	1.90	4.01	1.15	1.28
4	Small barrel	8533-8202	8533-8171	Blue/green	8-6	9-14	6.71	7.41	7.3	8.5
	Standard	8533-8201	8533-8120	Blue/blue	4	22	6.71	7.41	7.3	8.5

Crimp contacts 260°C

Contact size	Type	Part numbers		Code		Admissible wire section		External Ø over insulator		Mass g (±15%)	
		Pin	Socket	Color bands	Dot	AWG	mm²	Min.	Max.	Pin	Socket
20	Standard	8533-1000 900	8533-1011 900	Red/red	White	24-20	0.25-0.60	0.85	2.10	0.24	0.29
	Large barrel	8533-1002 900	8533-1012 900	Red/brown	White	24-18	0.25-1	0.85	2.10	0.24	0.29
	x2 crimping	8533-1019 900	8533-1018 900	Red/green	White	22	0.40	-	1.25	0.24	0.29
16	Standard	8533-1004 900	8533-1005 900	Blue/blue	White	20-16	0.60-1.20	1.20	2.70	0.53	0.59
	Small barrel	8533-1008 900	8533-1009 900	Blue/brown	White	24-18	0.25-1	1.20	2.70	0.53	0.59
	Large barrel	8533-1006 900	8533-1007 900	Blue/white	White	18-14	1-2	1.20	2.70	0.53	0.59
12	Standard	8533-1035 900	8533-1036 900	Yellow/yellow	White	14-12	2-3	1.90	4.01	1.15	1.28
	Large barrel	8533-1014 900	8533-1015 900	Yellow/brown	White		3-4	1.90	4.01	1.15	1.28

Crimp contacts 200°C and 260°C

Contact size	Type	Part numbers		Code		Admissible wire section		External Ø over insulator		Mass g (±15%)	
		Pin	Socket	Color bands		AWG	mm²	Min.	Max.	Pin	Socket
6	Standard	8533-8246	8533-8247	Green/green		6	14	5.30	5.70	3.6	4.8
	Small barrel	8533-8272	8533-8273	Green/red		8	9	5.30	5.70	3.6	4.8
	Small barrel	8533-8248	8533-8249	Green/brown		10-12	5-3	5.30	5.70	3.6	4.8

Thermocouple contacts (-65°C to +260°C)

Chromel - Pin contacts (non magnetic)

Contact size	Type	Part numbers	Code		Admissible wire section		External Ø over insulator	
			Color bands	Dot	AWG	mm ²	Min.	Max.
20	Standard	8522-875	Red/red	Yellow/white	22-20	0.40-0.60	0.85	2.10
		8522-875 A	Brown/orange/green					
	Large barrel	8522-3761		Yellow/yellow	22-18	0.38-0.93	0.85	2.10
16	Standard	8522-881	Green/brown/violet	Yellow	20-16	0.60-1.34	1.20	2.70
		8522-402	Blue/blue	Yellow	20-16	0.60-1.34	1.20	2.70

Chromel - Socket contacts (non magnetic)

Contact size	Type	Part numbers	Code		Admissible wire section		External Ø over insulator	
			Color bands	Dot	AWG	mm ²	Min.	Max.
20	Standard	8522-877 900	Red/red	Yellow/white	22-20	0.40-0.60	0.85	2.10
		8522-877 A900	Brown/yellow/brown	Yellow				
	Large barrel	8522-3770		Yellow/yellow	22-18	0.38-0.93	0.85	2.10
16	Standard	8522-883 900	Green/red/red	Yellow	20-16	0.60-1.34	1.20	2.70
		8522-403 900	Blue/blue	Yellow				
	Small barrel	8526-5571 A900	Blue/red	Yellow	24-18	0.25-1	1.20	2.70

Alumel - Pin contacts (magnetic)

Contact size	Type	Part numbers	Code		Admissible wire section		External Ø over insulator	
			Color bands	Dot	AWG	mm ²	Min.	Max.
20	Standard	8522-876	Red/red	Black/white	22-20	0.40-0.60	0.85	2.10
		8522-876 A	Brown/orange/yellow	Black				
	Large barrel	8522-3760		Black/black	22-18	0.38-0.93	0.85	2.10
16	Standard	8522-882	Green/brown/blue	Black	20-16	0.60-1.34	1.20	2.70
		8522-401	Blue/blue	Black	20-16	0.60-1.34	1.20	2.70

Alumel - Socket contacts (magnetic)

Contact size	Type	Part numbers	Code		Admissible wire section		External Ø over insulator	
			Color bands	Dot	AWG	mm ²	Min.	Max.
20	Standard	8522-878 900	Red/red	Black/white	22-20	0.40-0.60	0.85	2.10
		8522-878A 900	Brown/yellow/black					
	Large barrel	8522-3771		Black/black	22-18	0.38-0.93	0.85	2.10
16	Standard	8522-884 900	Green/red/brown	Black	20-16	0.60-1.34	1.20	2.70
		8522-404 900	Blue/blue	Black				
	Small barrel	8526-5576A 900	Blue/red	Black	24-18	0.25-1	1.20	2.70

Contact ordering information

EN3155

Basic Series	EN3155	004	M	20	18	Barrel Size											
Contact style (see table beside):						22	20	18	16	14	12						
004: 260°C standard male	054: Thermocouple Ni Al male (alumel)			20		018	004	004									
005: 260°C standard female	055: Thermocouple Ni Al female (alumel)					019	005	005									
018: 200°C standard male	056: Thermocouple Ni Cr male (chromel)					044	018	018									
019: 200°C standard female	057: Thermocouple Ni Cr female (chromel)					045	019	019									
044: 260°C double crimping male							054	054									
045: 260°C double crimping female					055	055											
						056	056										
						057	057										
Contact type:								004	004								
M: Male								005	005								
F: Female								018	018			004					
Contact size: 20, 16, 12								019	019			005					
& Barrel size: 22, 20, 18, 16, 14, 12								054	054			018					
see table beside for allowed values according to contact styles								055	055			019					
								056	056								
								057	057								
														004			
								018						005			
								019						018			
														019			

Note: Color bands according to ISO8843.

ESC30

Basic Series	ESC30	P	20	NA
Contact type:				
P: 260°C male contact				
S: 260°C female contact				
Contact size: 20, 16, 12				
Contact material :				
NA: Nickel aluminum				
NC: Nickel chromium				
BC: Copper alloy				

Note: All dimensions are in millimeters (mm)

#8 Quadrax contacts

Contact type		Part numbers	Impedance	Release	T° Max
PC tail L= 4.45 mm	Pin	ETH1-1137A	100Ω	Rear	200°C
PC tail L= 6.35 mm	Pin	ETH1-1123A	100Ω	Front	200°C
Crimp	Pin	ETH1-1126A	100Ω	Rear	200°C
	Socket	ETH1-1127A	100Ω	Rear	200°C

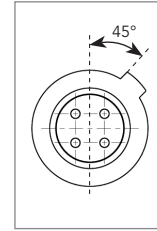

According to Airbus Standard.
Crimp contacts are unsealed. Sealing boots are available. All contacts delivered without boot.

Sealing boots

ABS 0992 for power & quadrax contacts - Class 260°C

Contact size	Cable AWG	Cable material	SOURIAU Part Numbers	A Max
4	4	Aluminum	8533-8164	17
	6 to 8	Aluminum	8533-8191	17
	4	Copper	8599-4591	9
	6 to 8	Copper	8533-8163	9
6	6	Aluminum & Copper	8533-8296	24
	8	Aluminum & Copper	8533-8236	24
	10 to 12	Aluminum & Copper	8533-8287	24
	Quad ABS0973 / 0974	Copper	8533-8236	24

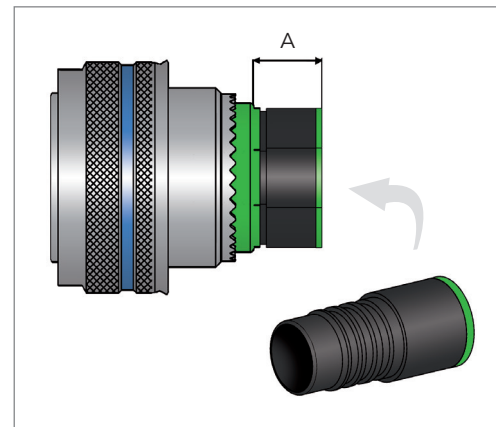

Filler plugs

These filler plugs are installed at the rear of unwired contacts to maintain connector sealing.

Contact size	Part numbers	Colors
20	8522-389A	red
16	8522-390A	blue
12	8522-391A	yellow
6	8530-2253	white
4	8533-8253	blue

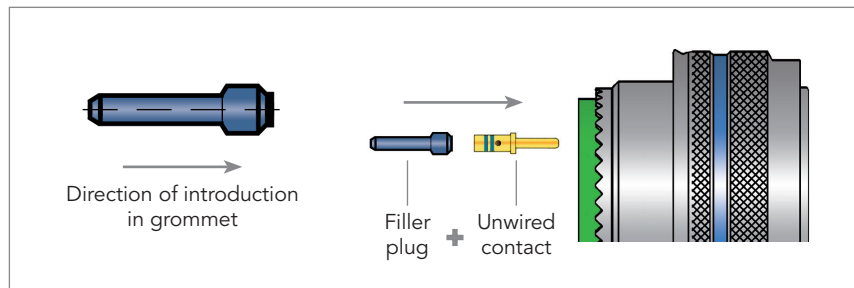

Note: All dimensions are in millimeters (mm)

Wiring instruction

Cable preparation and wire stripping

Size	Contact	20		16			12
	Barrel	20	18	16	14	28	12
Stripped length of cable mm ^{±0.5}		4.5		6.8			

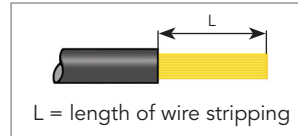

Insertion of wire in contact barrel

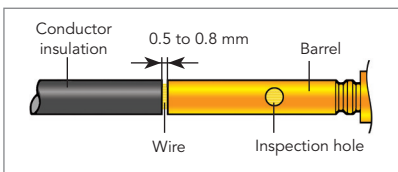

When inserting the stripped wire into the contact barrel check that no strands are left outside and that the wire is visible through the wire inspection hole in the barrel.

Important:

- Slide any accessories over wire strands before carrying out the following operations.
- Contacts are inserted and extracted from the rear of the connector.

Insertion of the contacts

1 - Engage the crimp cable / contact assembly into the longitudinal slot of the plastic tool (colored tip). Slide the tool down the cable until the tip of the tool abuts the contact retention shoulder.

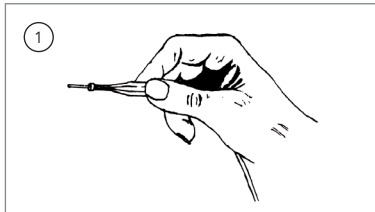

2 - Introduce the contact into the required contact cavity in the insulator, pushing tool axially, until the contact snaps into position in clip.

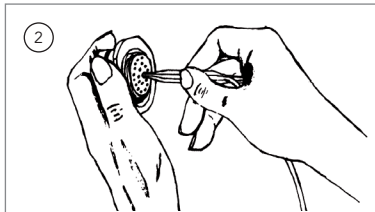

3 - Withdraw the tool from rear. Check that contact is firmly locked by pulling wire gently. When connector is fully loaded, check the position of contact tips. They should all be in the same plane. Note: For larger sizes of cable which are stiff enough, manual insertion without tool is preferable.

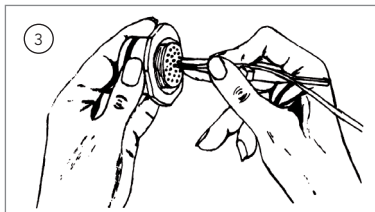

Extraction of the contacts

1 - Engage the appropriate cable into the longitudinal slot of the tool with the white tip towards connector.

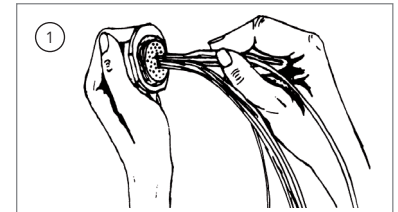

2 - Slide the tool down towards the contact. Insert the tool in the insulator until it abuts the contact shoulder.

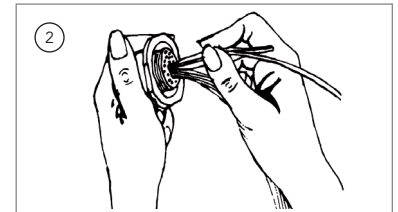

3 - Holding the tool-contact and cable assembly together, remove them simultaneously.

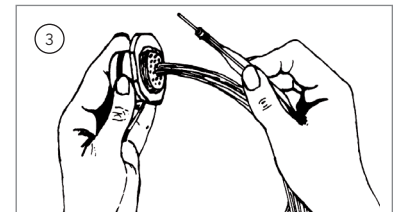

Insertion and extraction tools

Insertion and extraction of wired contacts

Contact size	Part numbers	Material	Color
20	M81969/14-11	Plastic	white / red
16	M81969/14-03	Plastic	white / blue
12	M81969/14-04	Plastic	white / yellow
6	M81969/14-06	Plastic	red
	8660-197	Metallic	-
4	M81969/14-07	Plastic	blue
	8533-8175	Metallic	-

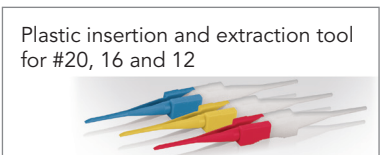

Extraction of unwired contacts

Contact size	Part numbers
20	8522-56
16	8522-57
12	8522-58

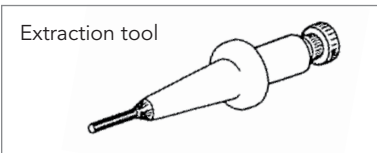

Crimping tools

Contact size	Wires		Part numbers		
	mm ²	AWG	Crimping pliers	Locator	Die set
20	0.93	18	8365 (M22520/1-01) or 8476-01 (M22520/1-01)	8365-02 (M22520/1-02) or 8476-02 (M22520/1-02)	
	0.60	20			
	0.38	22			
	0.21	24			
16	1.91	14	8365 (M22520/1-01)	8365-02 (M22520/1-02)	-
	1.34	16			
	0.93	18			
	0.60	20			
	0.38	22			
12	3.18	12	8365 (M22520/1-01)	8365-02 (M22520/1-02)	
	1.91	14			
6	14	6	M22520/23-01	8530-2036 (for male contact) 8530-2037 (for female contact)	M22520/23-02
	9	8	M22520/23-01	8530-2036 (for male contact) 8530-2037 (for female contact)	M22520/23-02
	5-3	10-12	M22520/23-01	8530-2036 (for male contact) 8530-2037 (for female contact)	WA23-112DA (23-02)
4	9-14	8-6	M22520/23-01	8533-8141 (23-11)	M22520/23-02
	22	4	M22520/23-01	8533-8141 (23-11)	M22520/23-04

Contact size		Part numbers	
		Crimping pliers	Locator
Quadrax	Inner contact	M22520/2-01	K709
	Outer contact	M22520/5-01	M22520/5-45

Tightening support

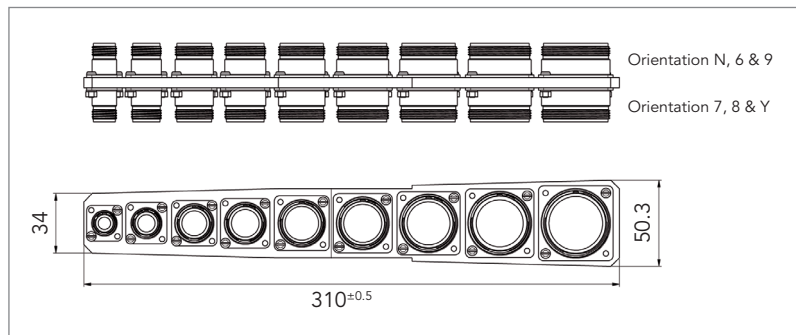

Aluminum version, part number: 8533-1150 (consult us)
 Stainless steel version, part number: 8533-1151

Backshell tightening tool

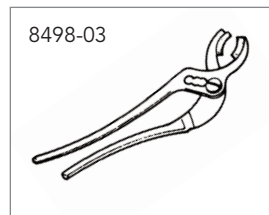

Backshell tightening plier,
 part number: 8498-03
 Square jaws (order 2 jaws),
 part number: 8500-1015

Silicone gaskets

Shell size	Gasket for square flange receptacle		O'ring for jam nut recep. 200°C Class		O'ring for jam nut recep. 260°C Class	
	Part number	Material	Part number	Material	Part number	Material
08	85251431	Fluoro silicone	8530455	Silicone	85227654	Silicone THT
10	85251432	Fluoro silicone	85300795	Silicone	85227655	Silicone THT
12	85251433	Fluoro silicone	8530458	Silicone	85227656	Silicone THT
14	85251434	Fluoro silicone	8530796	Silicone	85227632	Silicone THT
16	85251435	Fluoro silicone	8530797	Silicone	85227657	Silicone THT
18	85251436	Fluoro silicone	8530798	Silicone	85227658	Silicone THT
20	85251437	Fluoro silicone	85301548	Silicone	85227927	Silicone THT
22	85251438	Fluoro silicone	8530800	Silicone	85227659	Silicone THT

Grounding ring replacement kit

Please see SOURIAU Technical Bulletin BT210. Contact us.

Protective caps

Receptacle stainless steel cap

C Type

N Type

Basic Series	8533	KE	3	C	14
Class:					
KE: 260°C					
Stainless steel cap for receptacle					
Type:					
C: With chain					
N: Without chain					
Shell size (For other size, please consult us):					
12, 14, 16, 20					

Note: All dimensions are in millimeters (mm)

Dummy receptacle stainless steel version

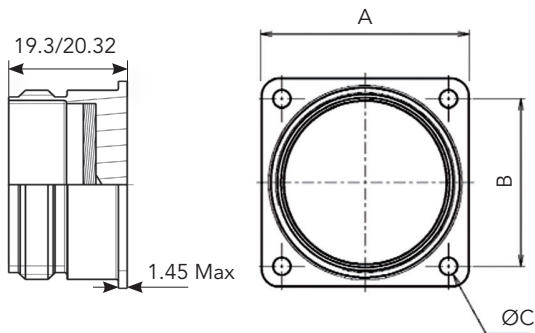

Note: Dummy receptacle without keying.

Shell size	08	10	12	14	16	18	20	22	24	28
A Max	20.75	23.93	26.32	28.71	31.88	34.24	36.63	39.80	43.39	50.93
B	15.09	18.26	20.62	23.01	24.61	26.97	29.36	31.75	34.92	39.67
Ø C Max	3.30								3.91	

Basic Series	8533	KE	5	10
Class: KE: 260°C				
5: Dummy receptacle				
Shell size: 08, 10, 12, 14, 16, 18, 20, 22, 24, 28				

Modelling receptacle aluminum version

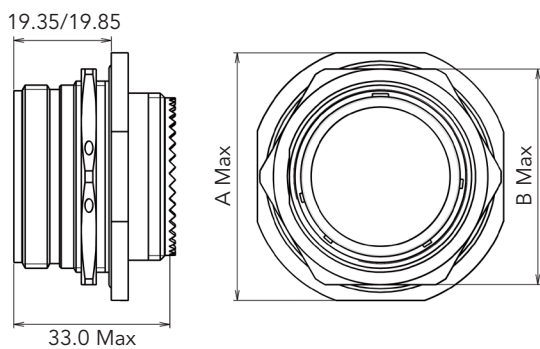

Shell size	08	12	16	22	24	28
A Max	24.90	32.79	38.51	49.63	52.81	59.18
B Max	21.03	28.96	33.76	43.31	48.06	54.48

Basic Series	8533	V7	R	08	N
V: Modelling jam nut receptacle					
R: 200°C aluminum conductive plating					
Shell size: 08, 12, 16, 22, 24, 28					
Orientation: N, 6, 7, 8, 9, Y					

Coordinates information

Please consult norm.

Note: All dimensions are in millimeters (mm)

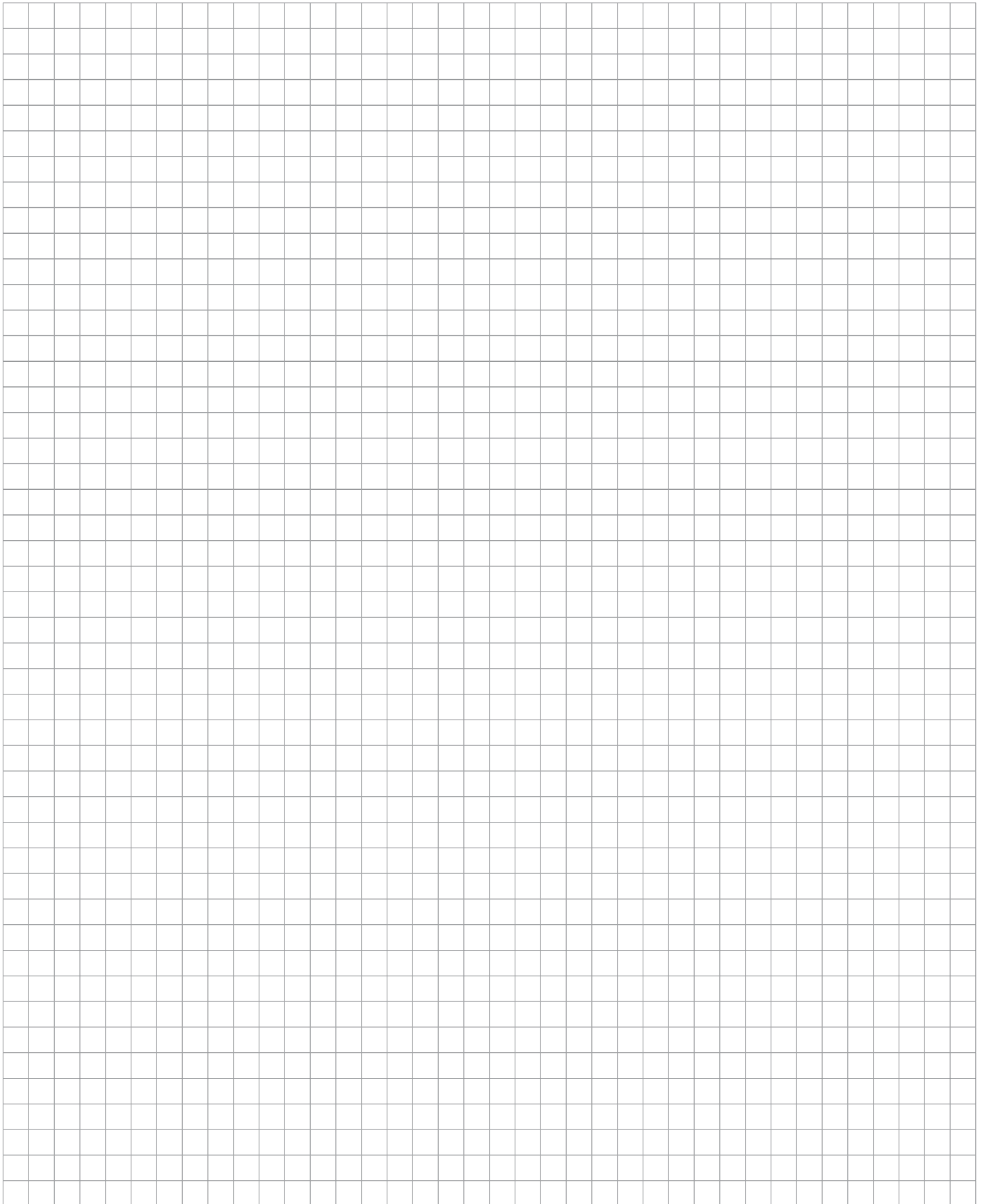

853 SERIES

853 Series

Range Extension

■ 230V connector	56
■ Fire resistant seal	56
■ Power contacts for PCB	57
■ Customizable shunted plug	57
■ Hermetic connector with removable contacts	58
■ Filtered connector	58

Product range extension

230V Connector

The use of higher voltage to reduce cable weight has led to the development of double voltage in un-pressurized connectors.

Robust design and materials:

- . ensuring that in un-pressurized areas no partial discharge will weaken the connector.
- . each production batch is tested to ensure performance to this high level.

No possible mismatch:

- . specific T and V locking to avoid mating with a non 230V qualified counterpart.

Flexible offering:

- . available in standard watertight as well as in hermetic connectors.
- . available in composite and stainless steel shells.



Fire Resistant Seal

Secured cable routing thanks to a fire stop design. Ideal for engine & APU (Auxiliary Power Unit) for aircrafts applications.

Fire resistant:

- . Ceramic insulator to enable 1100°C during 20 min.

High temperature:

- . Perfect resistance at up to 260°C.
- . Adapted to power cable.

Excellent vibration withstanding:

- . Avoid cable movement under vibrations.

Space saving compare to bulkhead connectors:

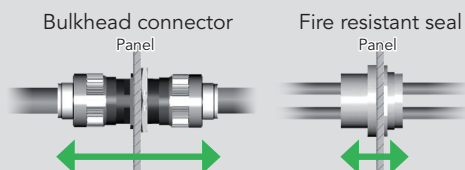

Product range extension

Power Contacts for PCB

Firewall connector for power supply, adapted to PCB solutions.

Safe & Quick Avoid soldering of contacts:

- . No heat applied: no risk of damaging the connector.
- . Quicker fit in the equipment.

Robust:

- . True mechanical link between PCB and contacts: no additional double flange needed. Power contacts are attached directly to the board with screws for an optimized connection.
- . Available in size 6 contact (Ø4.6mm) & size 4 contact (Ø5.74mm).

Compact:

- . Tapped contacts for direct and small sized connections, especially compared to standard lugs.



See «EN2997 Series Power Contacts for PCB» product news on www.souriau.com

Customizable Shunted Plug

Acting like a "car key", this device is modeling a code sequence that the engine calculator reads to authorize the starting.

Coding:

- . Coding is done with contacts.
- . Some are bi-stable contacts: to open or close a circuit.

SOURIAU advantage:

- . Our technology provides excellent contacts retention, preventing any unexpected code change during operation.

Range:

- . This product is based on MIL-STD-38999 Series III derivate or EN2997 derivate.
- . Aluminum or stainless steel materials are available.

Accessories:

- . This connector can be delivered with a rear cap that protects the coding.

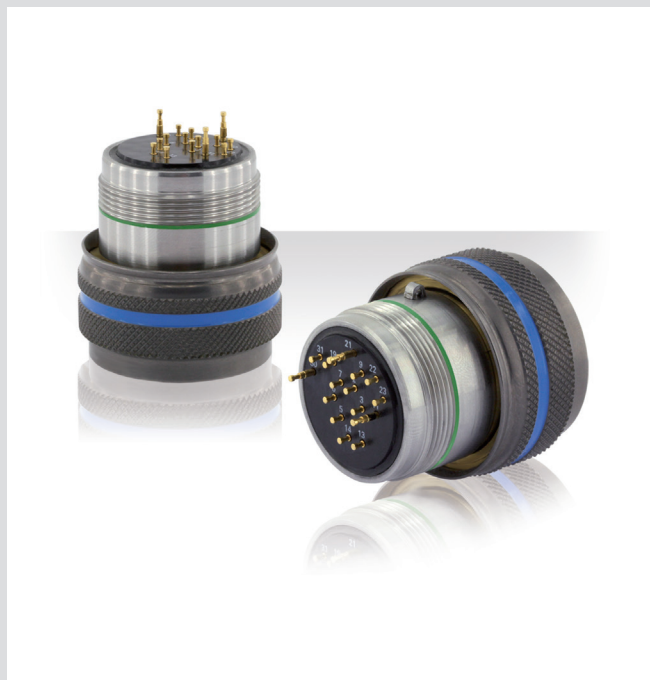

Product range extension

Hermetic Connector with Removable Contacts

Extension of the fuel immersion range.

High hermeticity performance:

- . Glass to metal sealing: leakage of less than 10^{-9} atm.cm³/s.

Removable crimp contacts:

- . A technology combining crimp contacts with glass beads
- . RoHS: no lead used.
- . Long lifetime: superior to solder cup contacts in kerosene immersion.
- . Easy MRO: contact replacement.

Long term fuel immersion materials:

- . Performances guaranteed for minimum 90,000 hours in fuel immersion.

Wide Availability:

- . EN3646 (Airbus Qualified Products).
- . EN2997, EN3645, MIL-DTL-38999.



See «MIL-DTL-38999, EN3646, EN2997 Fuel Tank Connector» product news on www.souriau.com

Filtered Connector

Protection of sensitive electronic components inside the equipment against any EMI or lightning interference as well as protection of signal integrity.

Signal Integrity principles - EMI/RFI Filter:

- . Protection of sensitive electronic components inside equipment.
- . Signal integrity (incoming data noise free / prevents noise exiting the equipment).

Space/weight/time saving:

- . Less electronics inside the equipment.
- . Filtered receptacles are generally standard length.

Excellent performance/reliability adapted to Mil-aero environments:

- . Insertion loss (attenuation) to -80dB at critical frequencies.
- . Filter ideally positioned at system entry point.
- . Tested as per MIL-STD-220.

A complete solution: Optional TVS functionality, Hermetic version available, 100 % ITAR free solution if required.

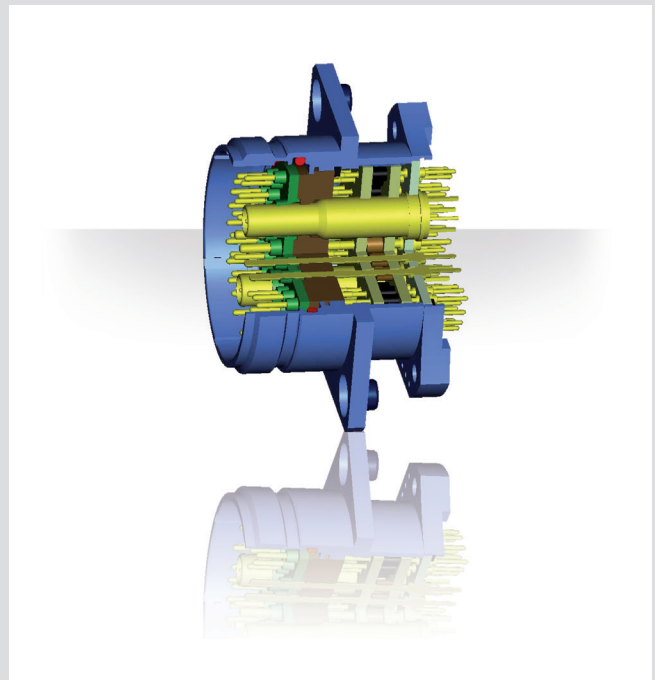

Reliable People, Reliable Solutions

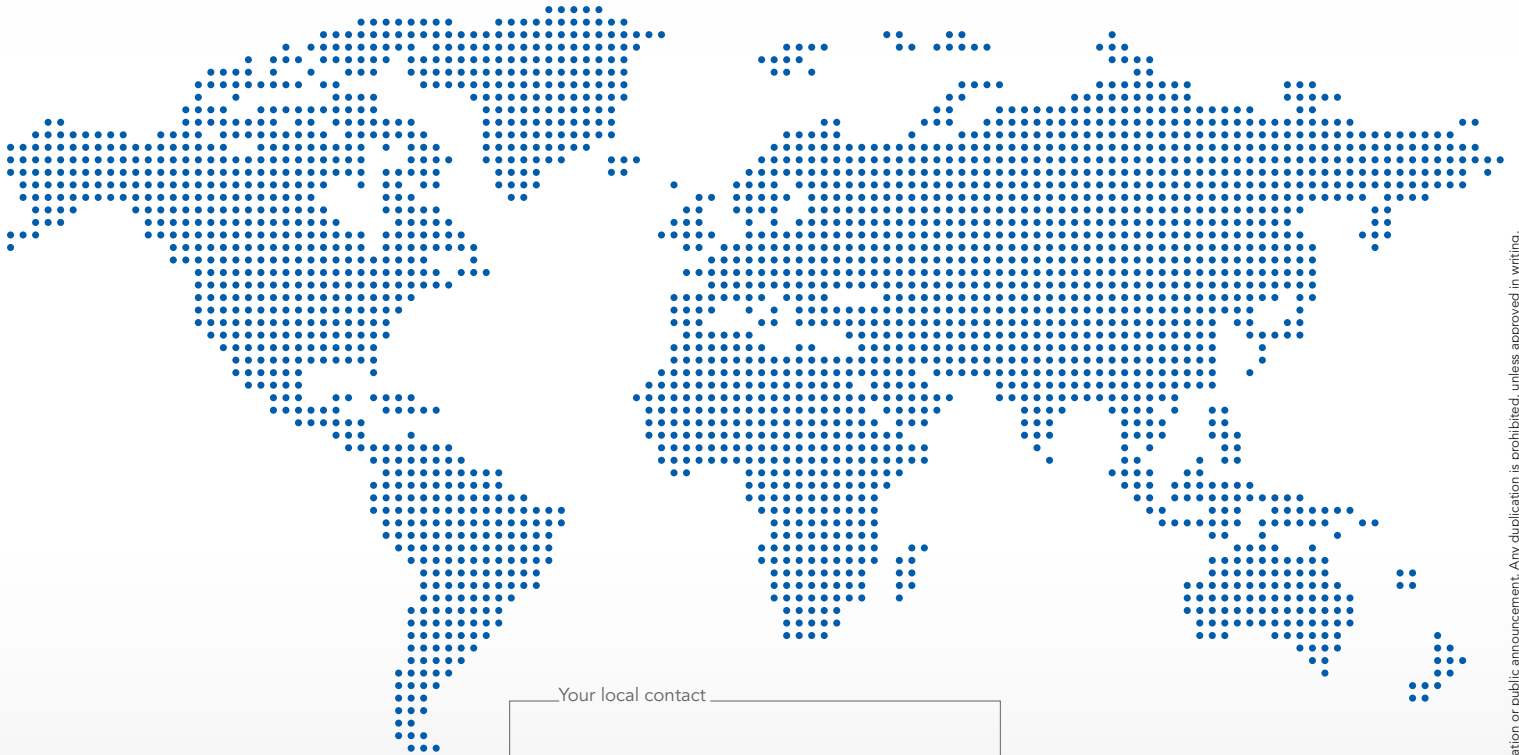

Your local contact



Our contribution to environmental protection:
This catalog is printed on PEFC certified paper
Advancement of sustainable wood cultivation. www.pefc.org

www.souriau.com
technical.emear@souriau.com (Europe - Asia - Africa)
technical.americas@souriau.com (North America)

