

# Camera Module Sockets

## Table of Product

Applicable Module Size	Type	Part No.	Page
5 × 5	On Board	CLE9120-2701F	3
	Through Board	CLE9120-2601F	3
5.8 × 5.8	On Board	CLE9120-6601F	3
	On Board	CLE9124-1601F	4
6 × 6	On Board	CLE9020-0501F	4
	Top Shield	CLE9020-0603F	4
	On Board	CLE9120-1001F	5
	Top Shield	CLE9120-2201F	5
	Through Board	CLE9020-0801F	5
	On Board	CLE9120-7801F	6
6.5 × 6.5	Top Shield	CLE9120-7901F	6
	On Board	CLE9124-6901F	6
7 × 7	Top Shield	CLE9124-8201F	7
	On Board	CLE9124-4001F	7
8 × 8	On Board	CLE9124-1501F	7
	On Board	CLE9124-1502F	8
	On Board	CLE9124-4501F	8
	Top Shield	CLE9124-1401F	8
	Through Board	CLE9124-3801F	9
	On Board	CLE9124-7001F	9
8.5 × 8.5	On Board	CLE9124-4801F	9
	On Board	CLE9116-8801F	10
	On Board	CLE9132-8701F	10
	Through Board	CLE9132-9101F	10
10 × 10	On Board	CLE9028-0201F	11
	Top Shield	CLE9028-0301F	11
11.5 × 13.5	On Board	CLE9130-2801F	11
11.5 × 11.5	On Board	CLE9130-4901F	12
SMIA65	On Board	CLE9112-1101F	13
	Through Board	CLE9112-2301F	13
SMIA85	On Board	CLE9014-1311F	13
	Through Board	CLE9114-1201F	14
SMIA95	On Board	CLE9016-0111F	14

## Features

1. Highly reliable contact and locking structures.
  2. Designed for ensured shielding performance.
  3. Shorter assembly time and easier assemblability than FPC mounted solution.
- \*Patents pending.



## Specification

- Rating .....0.5A, 50V AC/DC
- Contact Resistance .....30mΩ, max.
- Insulation Resistance .....100MΩ min. at 100V DC
- Withstanding Voltage .....100V AC ( for one minute )
- Operating Temperature Range .....-30°C to +85°C

## Application

Mobile phones, PHS, equipment for games, etc

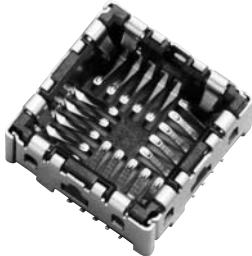
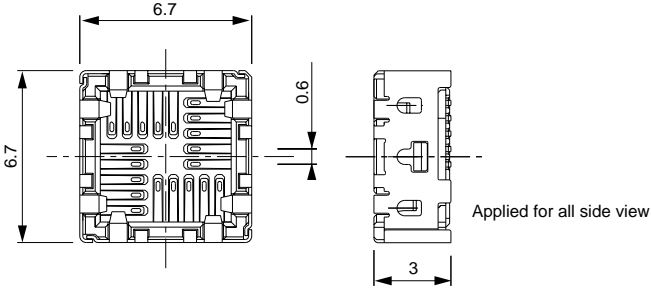
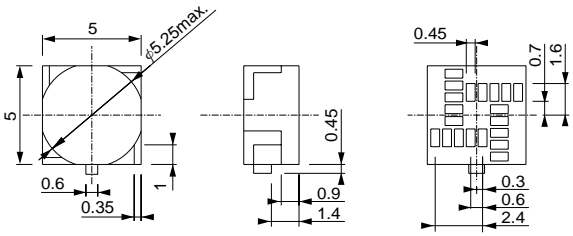
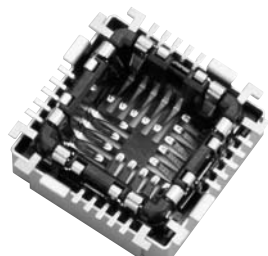
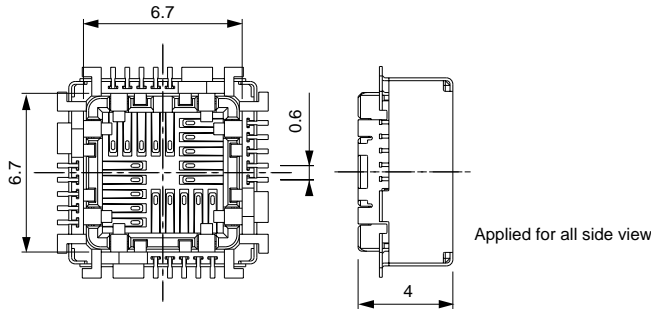
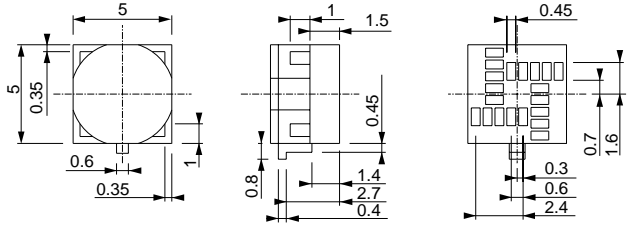
# for 5 × 5 Size Camera Module

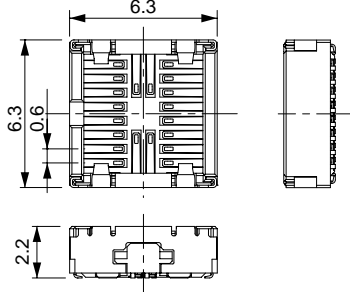
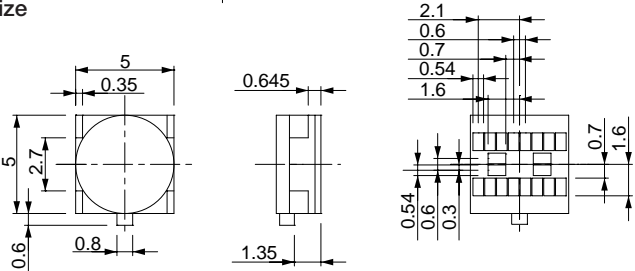
<p><b>CLE9120-2701F</b></p> 	<p>■ Dimension</p>  <p>■ Applicable Module Size</p> 
<p>On Board Type</p>	
<p><b>CLE9120-2601F</b></p> 	<p>■ Dimension</p>  <p>■ Applicable Module Size</p> 
<p>Through Board Type</p>	
<p><b>CLE9120-6601F</b></p> 	<p>■ Dimension</p>  <p>■ Applicable Module Size</p> 
<p>On Board Type</p>	

## for 5.8 × 5.8 Size Camera Module

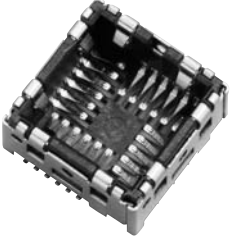
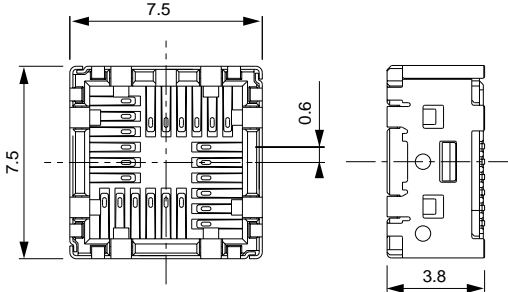
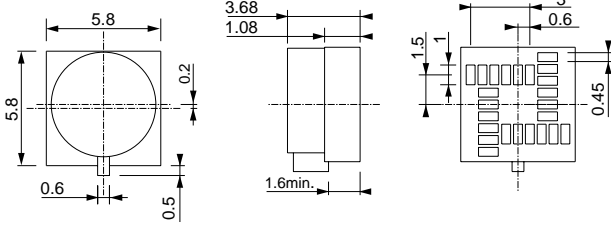
<p><b>CLE9124-1601F</b></p> 	<p>■Dimension</p>  <p>Applied for all side view</p> <p>■Applicable Module Size</p> 
<p>On Board Type</p>	

## for 6 × 6 Size Camera Module

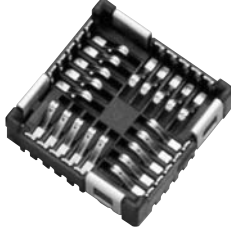
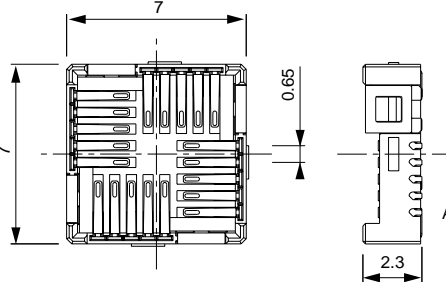
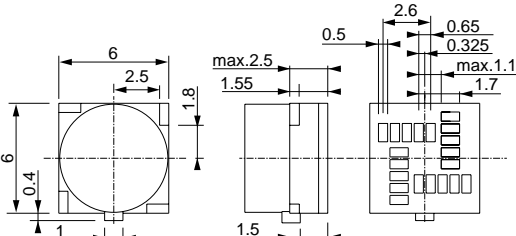
<p><b>CLE9020-0501F</b></p> 	<p>■Dimension</p>  <p>Applied for all side view</p> <p>■Applicable Module Size</p> 
<p>On Board Type</p>	

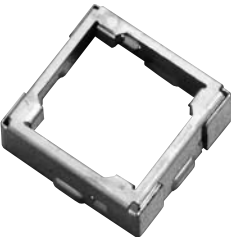
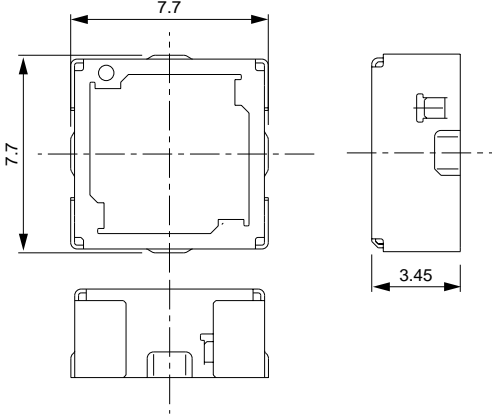
<p><b>CLE9020-0603F</b></p> 	<p>■Dimension</p>  <p>■Applicable Part No. ( Socket )</p> <p><b>CLE9020-0501F</b></p>
<p>Top Shield</p>	

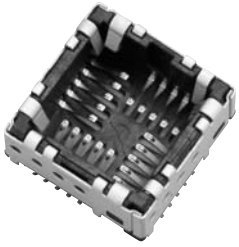
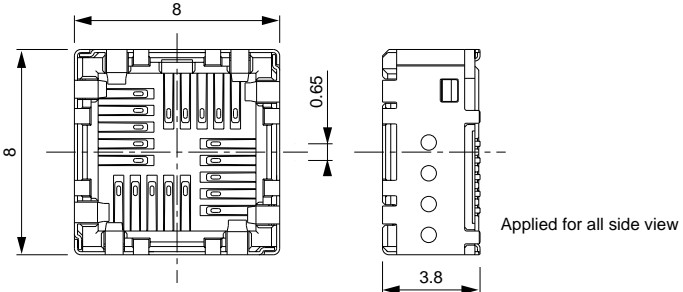
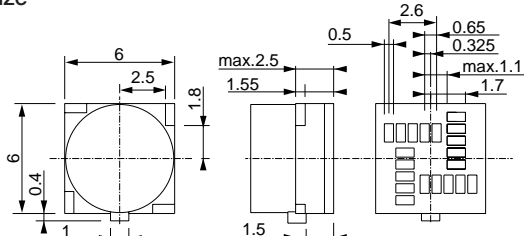
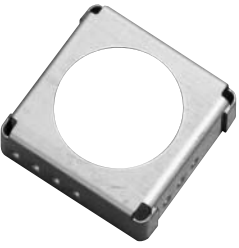
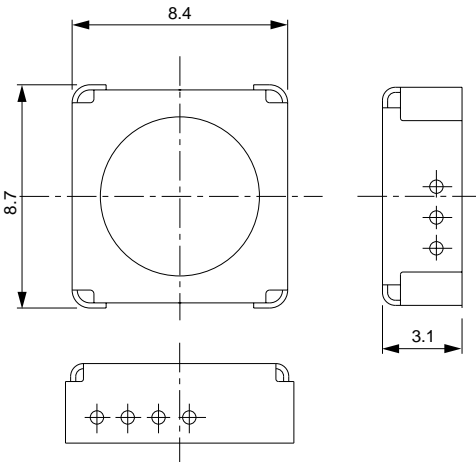
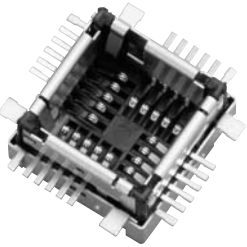
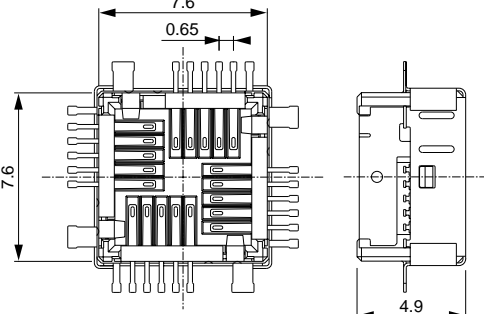
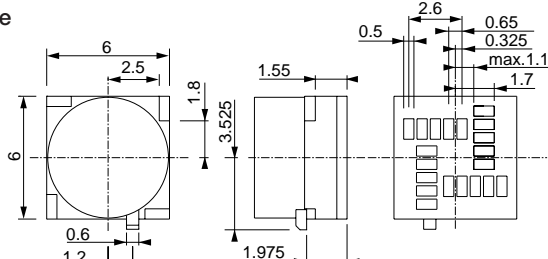
<p><b>CLE9120-1001F</b></p> 	<p>■Dimension</p>  <p>■Applicable Module Size</p> 
<p>On Board Type</p>	
<p><b>CLE9120-2201F</b></p> 	<p>■Dimension</p>  <p>■Applicable Socket</p> <p>CLE9120-1001F</p>
<p>Top Shield</p>	
<p><b>CLE9020-0801F</b></p> 	<p>■Dimension</p>  <p>■Applicable Module Size</p> 
<p>Through Board Type</p>	

## for 6 × 6 Size Camera Module

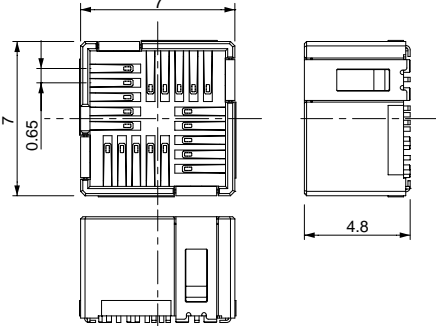
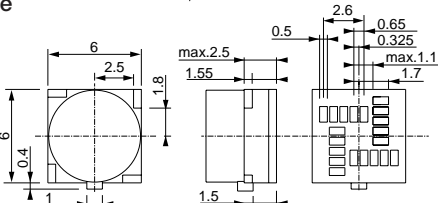
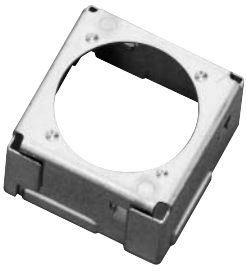
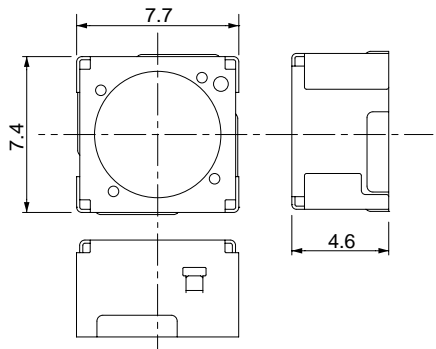
<p><b>CLE9120-7801F</b></p> 	<p>■Dimension</p>  <p>■Applicable Module Size</p> 
<p>On Board Type</p>	
<p><b>CLE9120-7901F</b></p> 	<p>■Dimension</p>  <p>■Applicable Socket</p> <p>CLE9120-7801F</p>
<p>Top Shield</p>	

## for 6.5 × 6.5 Size Camera Module

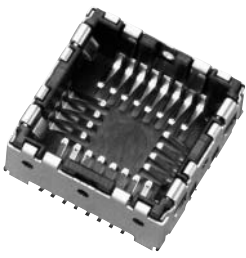
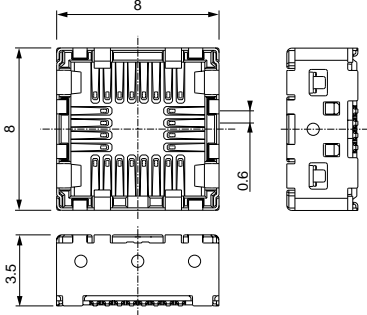
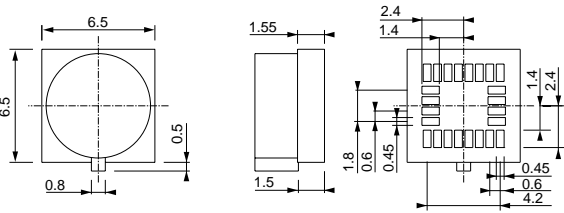
<p><b>CLE9124-6901F</b></p> 	<p>■Dimension</p>  <p>■Applicable Module Size</p> 
<p>On Board Type</p>	

<b>CLE9124-8201F</b>	<p>■ Dimension</p>
<p>Top Shield</p>	<p>■ Applicable Socket</p> <p style="text-align: center;"><b>CLE9124-6901F</b></p>

### for 7 × 7 Size Camera Module

<b>CLE9124-4001F</b>	<p>■ Dimension</p>
<p>On Board Type</p>	<p>■ Applicable Module Size</p>

### for 8 × 8 Size Camera Module

<b>CLE9124-1501F</b>	<p>■ Dimension</p>
<p>On Board Type</p>	<p>■ Applicable Module Size</p>

# for 8 × 8 Size Camera Module

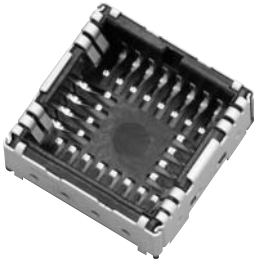
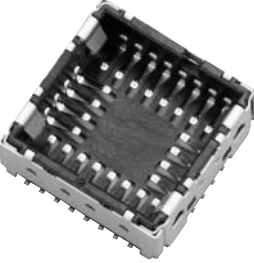
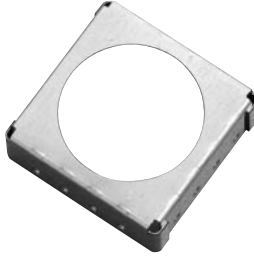
<p><b>CLE9124-1502F</b></p> 	<p>■ Dimension</p> <p>■ Applicable Module Size</p>
<p>On Board Type</p>	
<p><b>CLE9124-4501F</b></p> 	<p>■ Dimension</p> <p>■ Applicable Module Size</p>
<p>On Board Type</p>	
<p><b>CLE9124-1401F</b></p> 	<p>■ Dimension</p> <p>■ Applicable Socket</p>
<p>Top Shield</p>	<p>CLE9124-1501F CLE9124-1502F</p>

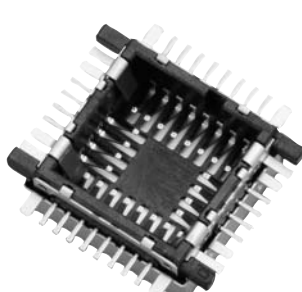
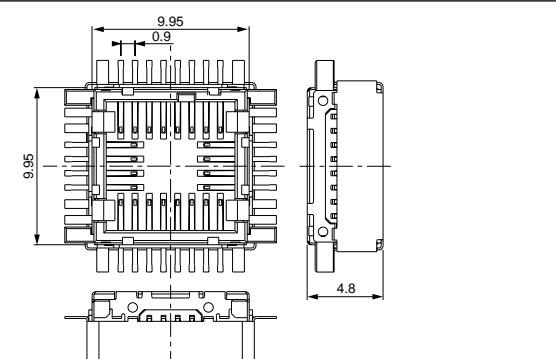
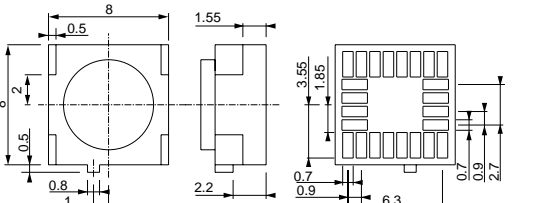
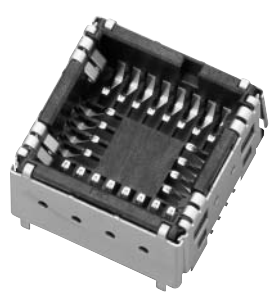
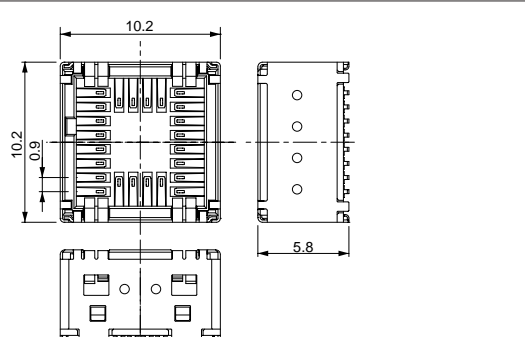
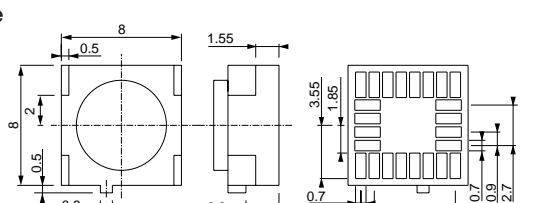
<p><b>CLE9124-3801F</b></p> 	<p>■ Dimension</p>  <p>■ Applicable Module Size</p> 
<p>Through Board Type</p>	
<p><b>CLE9124-7001F</b></p> 	<p>■ Dimension</p>  <p>■ Applicable Module Size</p> 
<p>On Board Type</p>	

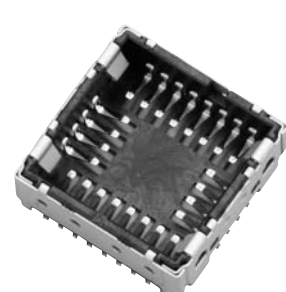
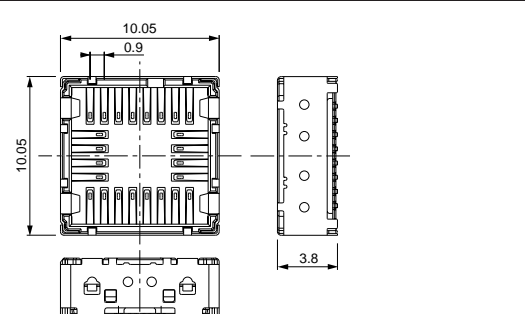
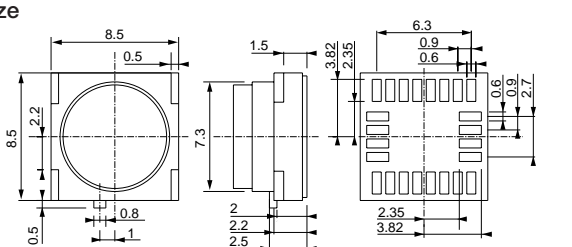

**for 8.5 × 8.5 Size Camera Module**

<p><b>CLE9124-4801F</b></p> 	<p>■ Dimension</p>  <p>■ Applicable Module Size</p> 
<p>On Board Type</p>	

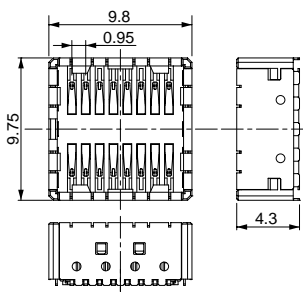
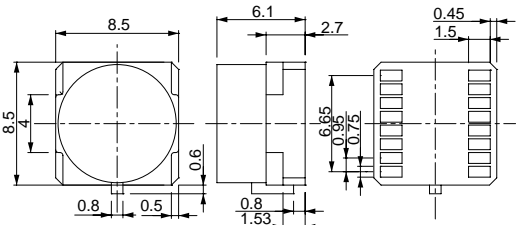
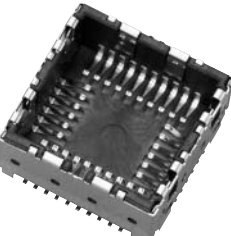
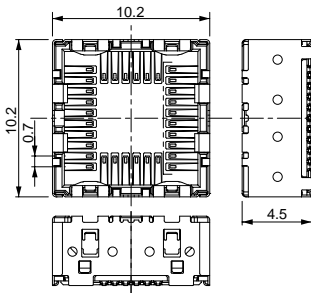
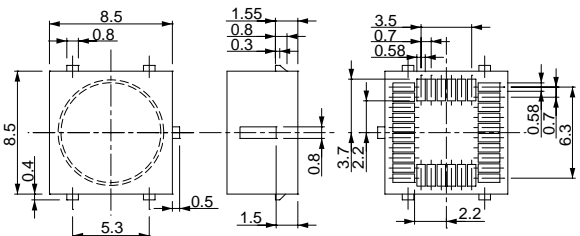
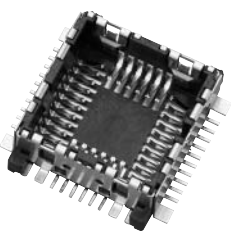
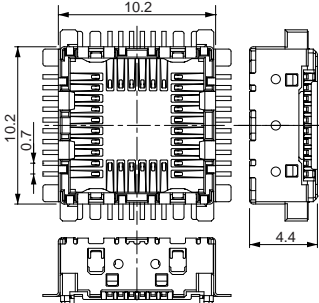
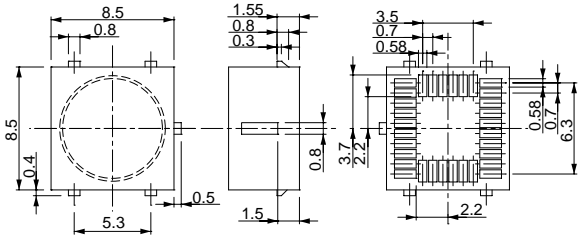
# for 8.5 × 8.5 Size Camera Module

<p><b>CLE9116-8801F</b></p> 	<p>■ Dimension</p>  <p>■ Applicable Module Size</p> 
<p>On Board Type</p>	
<p><b>CLE9132-8701F</b></p> 	<p>■ Dimension</p>  <p>■ Applicable Module Size</p> 
<p>On Board Type</p>	
<p><b>CLE9132-9101F</b></p> 	<p>■ Dimension</p>  <p>■ Applicable Module Size</p> 
<p>Through Board Type</p>	

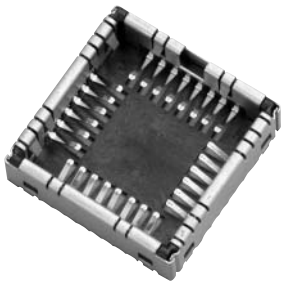
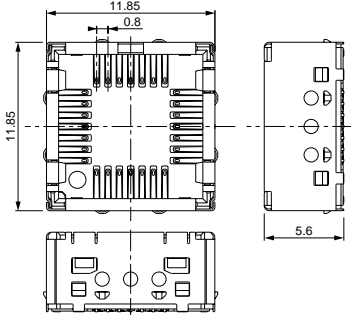
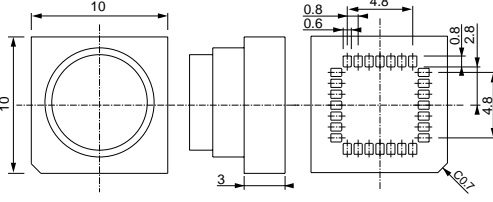
## for 10 × 10 Size Camera Module

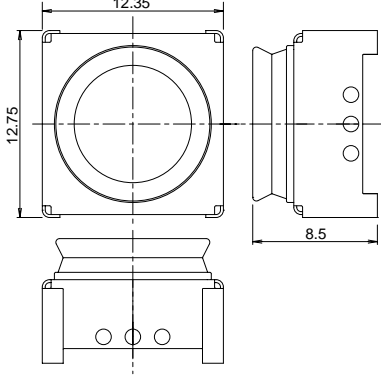
<p><b>CLE9028-0201F</b></p> 	<p>■ Dimension</p>  <p>■ Applicable Module Size</p> 
<p>On Board Type</p>	
<p><b>CLE9028-0301F</b></p> 	<p>■ Dimension</p>  <p>■ Applicable Socket</p> <p>CLE9028-0201F</p>
<p>Top Shield</p>	

## for 11.5 × 13.5 Size Camera Module

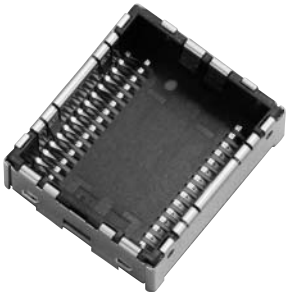
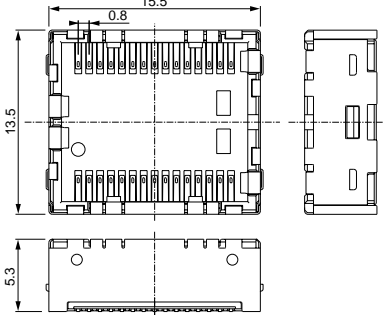
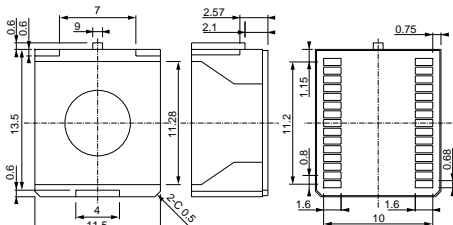
<p><b>CLE9130-2801F</b></p> 	<p>■ Dimension</p>  <p>■ Applicable Module Size</p> 
<p>On Board Type</p>	

# for 11.5 × 11.5 Size Camera Module

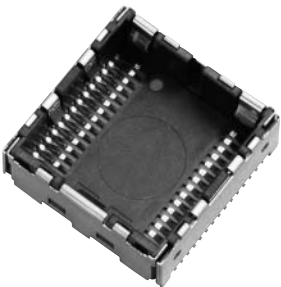
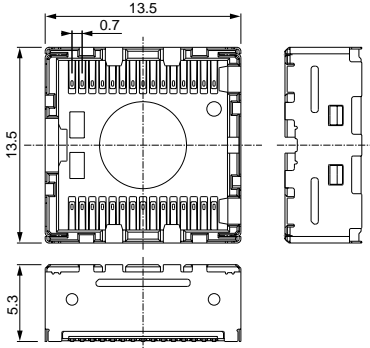
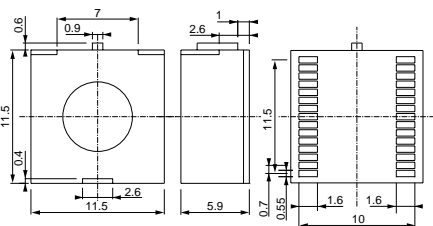
<p><b>CLE9130-4901F</b></p> 	<p>■ Dimension</p>  <p>■ Applicable Module Size</p> 
<p>On Board Type</p>	

## for SMIA65

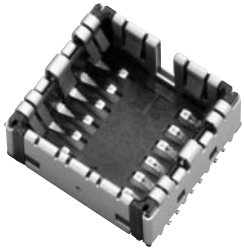
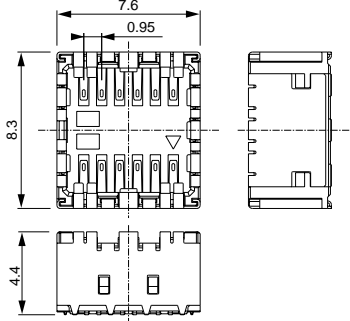
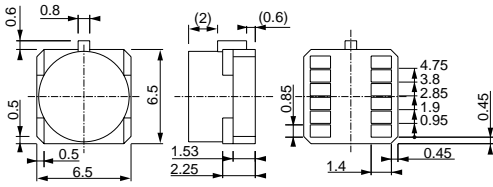
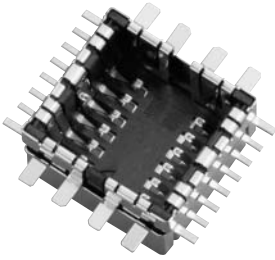
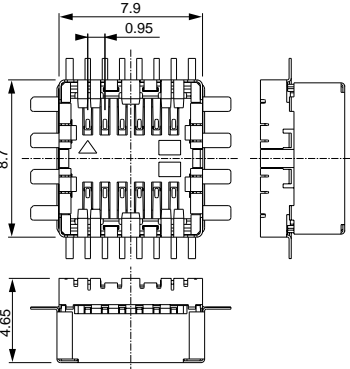
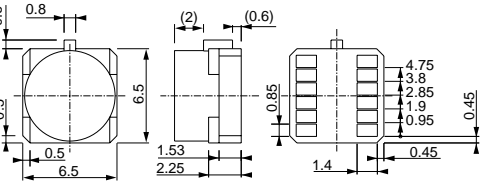
<p><b>CLE9112-1101F</b></p> 	<p>■ Dimension</p>  <p>■ Applicable Module Size</p> 
<p>On Board Type</p>	
<p><b>CLE9112-2301F</b></p> 	<p>■ Dimension</p>  <p>■ Applicable Module Size</p> 
<p>Through Board</p>	

## for SMIA85

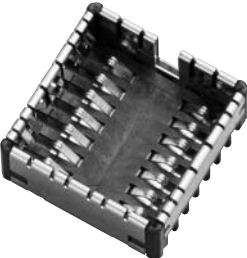
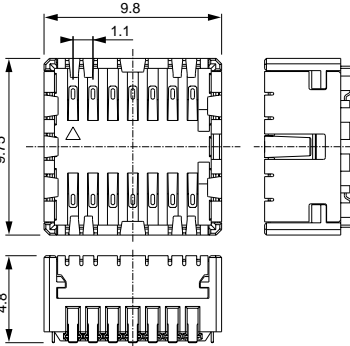
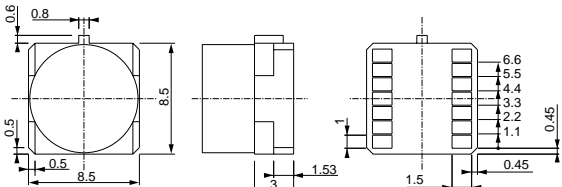
<p><b>CLE9014-1311F</b></p> 	<p>■ Dimension</p>  <p>■ Applicable Module Size</p> 
<p>On Board Type</p>	

## for SMIA85

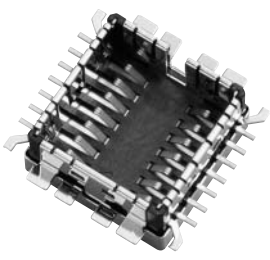
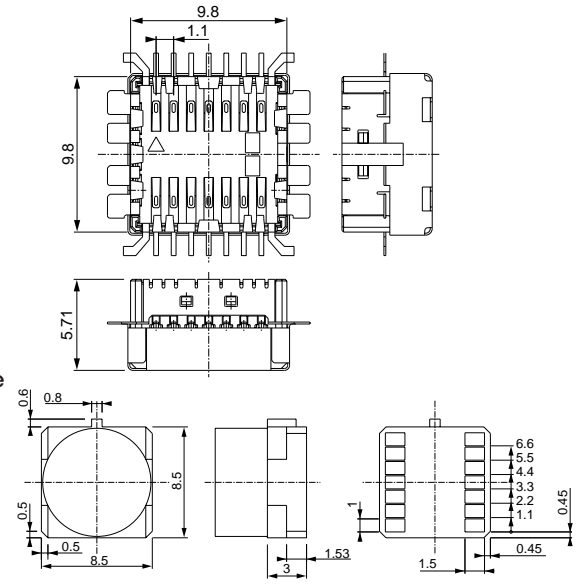
<p><b>CLE9114-1201F</b></p> 	<p>■ Dimension</p>  <p>■ Applicable Module Size</p>
<p>Through Board</p>	

## for SMIA95

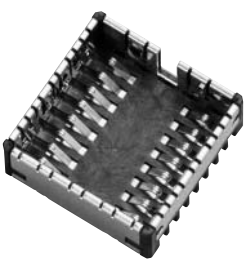
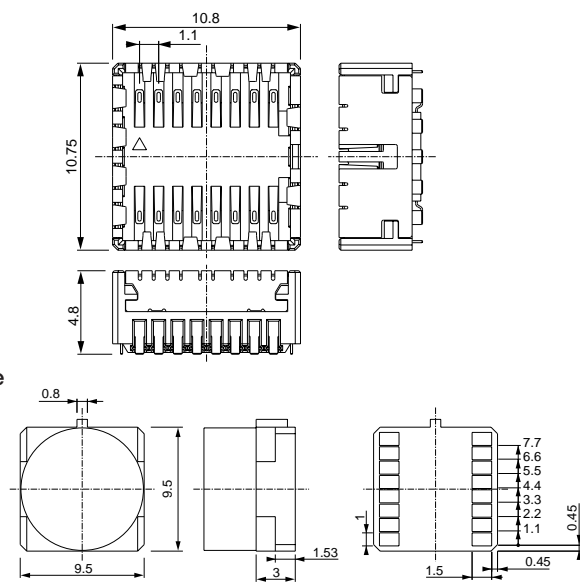
<p><b>CLE9016-0111F</b></p> 	<p>■ Dimension</p>  <p>■ Applicable Module Size</p>
<p>On Board type</p>	