

## Low Power, High ESD +5V RS232 Transceivers

- Meets All EIA-232 and ITU V.28 Specifications
- Single +5V Supply Operation
- 3mA Typical Static Supply Current
- 4 x 0.1µF External Charge Pump Capacitors
- Typical 230kbps Transmission Rates
- Standard SOIC and SSOP Footprints
- 1µA Shutdown Mode (SP211E & SP213E)
- Two Wake-Up Receivers (SP213E)
- Tri-State/RxEnable (SP211E & SP213E)
- Improved ESD Specifications:
  - ±15kV Human Body Model
  - ±15kV IEC1000-4-2 Air Discharge
  - ±8kV IEC1000-4-2 Contact Discharge

**Now Available in Lead Free Packaging**

Device	Drivers	Receivers	Pins
SP207E	5	3	24
SP208E	4	4	24
SP211E	4	5	28
SP213E	4	5	28

Table 1. Model Selection Table

### DESCRIPTION

The **SP207E-SP213E** are enhanced transceivers intended for use in RS-232 and V.28 serial communication. These devices feature very low power consumption and single-supply operation making them ideal for space-constrained applications. **Sipex**-patented (5,306,954) on-board charge pump circuitry generates fully compliant RS-232 voltage levels using small and inexpensive 0.1µF charge pump capacitors. External +12V and -12V supplies are not required. The **SP211E and SP213E** feature a low-power shutdown mode, which reduces power supply drain to 1µA. **SP213E** includes two receivers that remain active during shutdown to monitor for signal activity.

The **SP207E-SP213E** devices are pin-to-pin compatible with our previous SP207, SP208, SP211 and SP213 as well as industry-standard competitor devices. Driver output and receiver input pins are protected against ESD to over ±15kV for both Human Body Model and IEC1000-4-2 Air Discharge test methods. Data rates of over 120kbps are guaranteed with 230kbps typical, making them compatible with high speed modems and PC remote-access applications. Receivers also incorporate hysteresis for clean reception of slow moving signals.

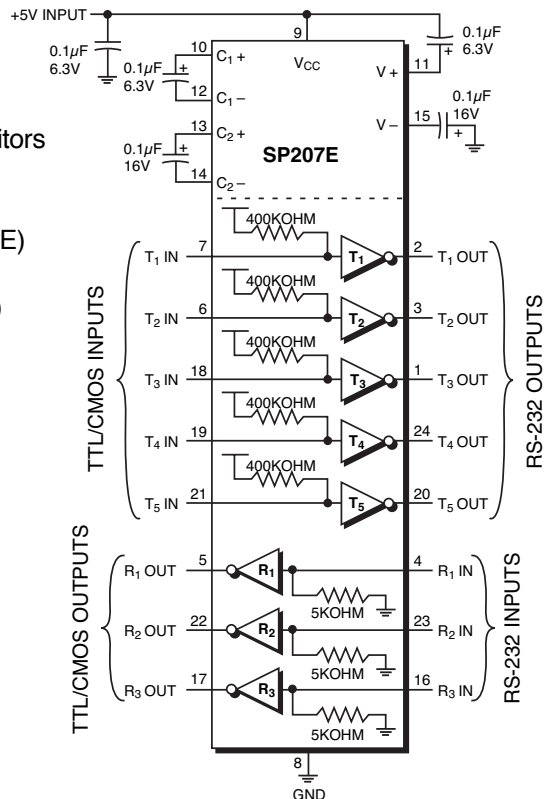

## ABSOLUTE MAXIMUM RATINGS

These are stress ratings only and functional operation of the device at these or any other above those indicated in the operation sections of the specifications below is not implied. Exposure to absolute maximum rating conditions for extended periods of time may affect reliability.

$V_{CC}$ .....	+6V
$V^+$ .....	( $V_{CC} - 0.3V$ ) to +13.2V
$V^-$ .....	13.2V
Input Voltages	
$T_{IN}$ .....	-0.3V to ( $V_{CC} + 0.3V$ )
$R_{IN}$ .....	$\pm 20V$
Output Voltages	
$T_{OUT}$ .....	( $V^+$ , +0.3V) to ( $V^-$ , -0.3V)
$R_{OUT}$ .....	-0.3V to ( $V_{CC} + 0.3V$ )
Short Circuit Duration on $T_{OUT}$ .....	Continuous

## Power Dissipation Per Package

24-pin SSOP (derate 11.2mW/°C above +70°C)....900mW  
 24-pin PDIP (derate 15.9mW/°C above +70°C)....1300mW  
 24-pin SOIC (derate 12.5mW/°C above +70°C)....1000mW  
 28-pin SSOP (derate 11.2mW/°C above +70°C)....900mW  
 28-pin SOIC (derate 12.7mW/°C above +70°C)....1000mW

## SPECIFICATIONS

$V_{CC}$  at nominal ratings; 0.1 $\mu$ F charge pump capacitors;  $T_{MIN}$  to  $T_{MAX}$ , unless otherwise noted.

PARAMETER	MIN.	TYP.	MAX.	UNIT	CONDITIONS
<b>TTL INPUTS</b>					
Logic Threshold			0.8	Volts	$T_{IN}$ , EN, SD
$V_{IL}$	2.0			Volts	
$V_{IH}$				Volts	
Logic Pullup Current		15	200	$\mu$ A	$T_{IN} = 0V$
Maximum Transmission Rate	120	230		kbps	$C_L = 1000pF$ , $R_L = 3K\Omega$
<b>TTL OUTPUTS</b>					
Compatibility		TTL/CMOS			
$V_{OL}$	3.5		0.4	Volts	$I_{OUT} = 3.2mA$ ; $V_{CC} = +5V$
$V_{OH}$				Volts	$I_{OUT} = -1.0mA$
Leakage Current		0.05	$\pm 10$	$\mu$ A	$0V \leq R_{OUT} \leq V_{CC}$ ; SP211 EN = 0V; SP213 EN = $V_{CC}$ $T_A = +25^\circ C$
<b>RS232 OUTPUT</b>					
Output Voltage Swing	$\pm 5$	$\pm 7$		Volts	All transmitter outputs loaded with 3K $\Omega$ to ground
Output Resistance	300			$\Omega$	$V_{CC} = 0V$ ; $V_{OUT} = \pm 2V$
Output Short Circuit Current		$\pm 25$		mA	Infinite duration, $V_{OUT} = 0V$
<b>RS232 INPUT</b>					
Voltage Range	-15		+15	Volts	
Voltage Threshold					
Low	0.8	1.2		Volts	$V_{CC} = 5V$ , $T_A = +25^\circ C$
High		1.7	2.8	Volts	$V_{CC} = 5V$ , $T_A = +25^\circ C$
Hysteresis	0.2	0.5	1.0	Volts	$V_{CC} = +5V$
Resistance	3	5	7	k $\Omega$	$V_{IN} = \pm 15V$ ; $T_A = +25^\circ C$
<b>DYNAMIC CHARACTERISTICS</b>					
Driver Propagation Delay		1.5		$\mu$ s	TTL-to-RS-232
Receiver Propagation Delay		0.5	1.5	$\mu$ s	RS-232-to-TTL
Instantaneous Slew Rate			30	V/ $\mu$ s	$C_L = 50pF$ , $R_L = 3-7K\Omega$ ; $T_A = +25^\circ C$ ; from $\pm 3V$
Transition Time			1.5	$\mu$ s	$C_L = 2,500pF$ , $R_L = 3K\Omega$ ; measured from +3V to -3V or -3V to +3V
Output Enable Time		400		ns	
Output Disable Time		250		ns	

# SPECIFICATIONS

$V_{CC}$  at nominal ratings; 0.1 $\mu$ F charge pump capacitors;  $T_{MIN}$  to  $T_{MAX}$ , unless otherwise noted.

PARAMETER	MIN.	TYP.	MAX.	UNIT	CONDITIONS
<b>POWER REQUIREMENTS</b>					
$V_{CC}$					
SP207	4.75	5.00	5.25	Volts	$T_A = +25^\circ\text{C}$ No load; $V_{CC} = \pm 10\%$ All transmitters $R_L = 3K\Omega$ $T_A = +25^\circ\text{C}$
All other parts	4.50	5.00	5.50	Volts	
$I_{CC}$		3	6	mA	
Shutdown Current		15	10	mA	
		1		$\mu\text{A}$	
<b>ENVIRONMENTAL AND MECHANICAL</b>					
Operating Temperature					
Commercial, -C	0		+70	$^\circ\text{C}$	
Extended, -E	-40		+85	$^\circ\text{C}$	
Storage Temperature	-65		+125	$^\circ\text{C}$	
Package					
-A	Shrink (SSOP) small outline				
-T	Wide (SOIC) small outline				
-P	Narrow (PDIP) Plastic Dual-In-Line				

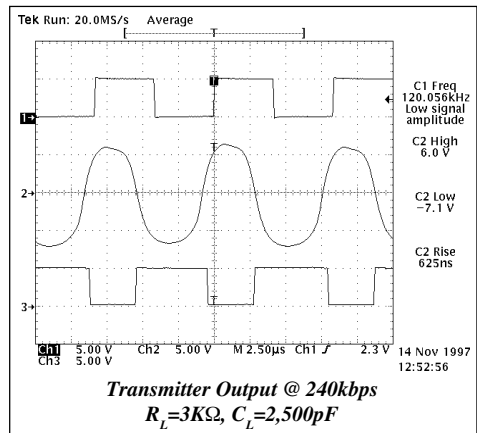
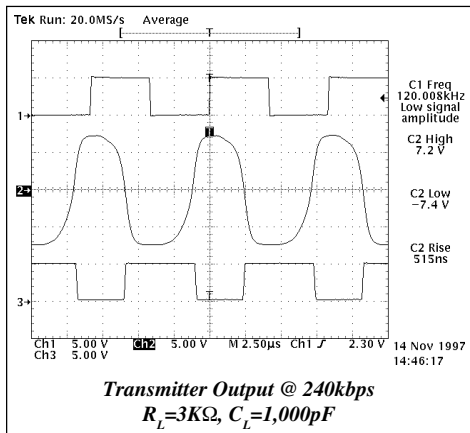
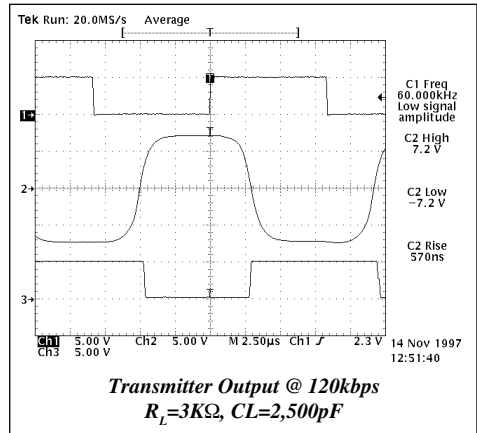
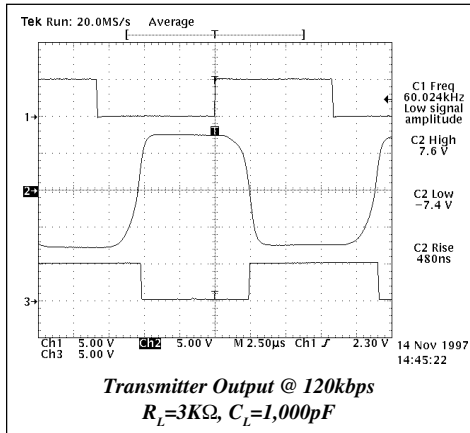

# PINOUT

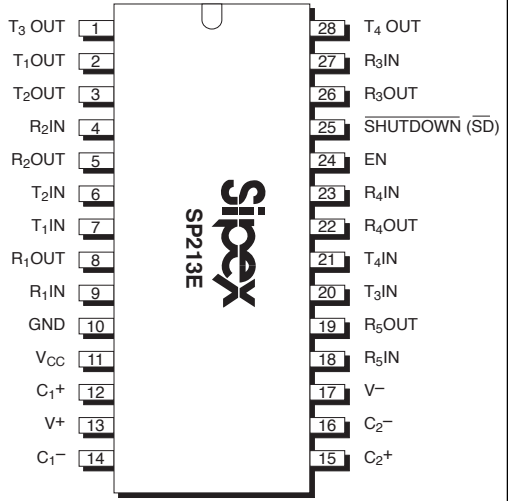
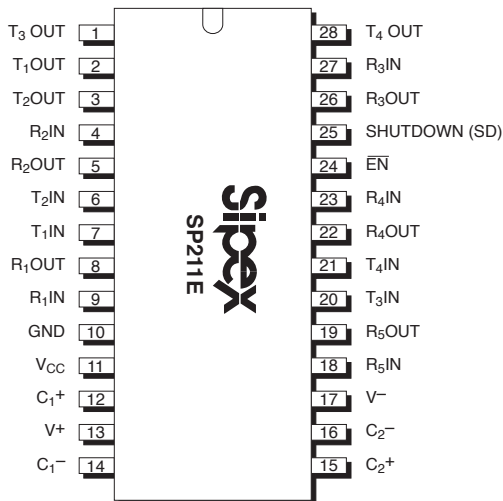
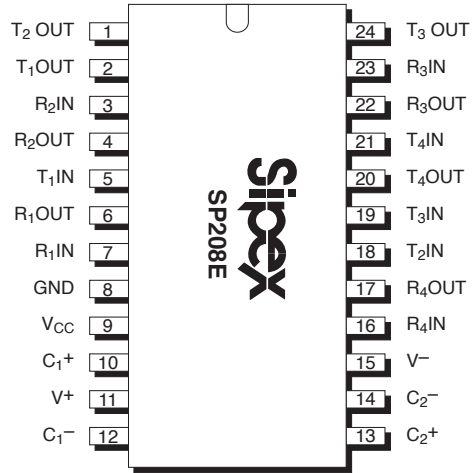
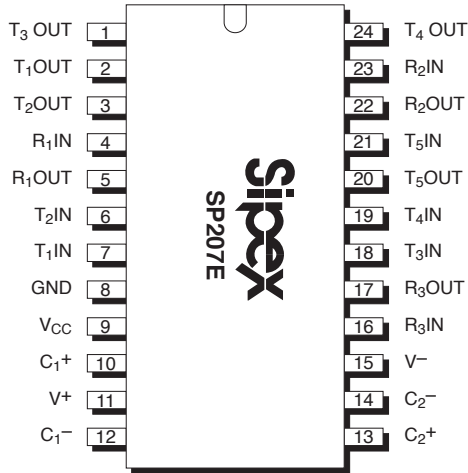

## FEATURES

The **SP207E**, **SP208E**, **SP211E** and **SP213E** multi-channel transceivers fit most RS-232/V.28 communication needs. All of these devices feature low-power CMOS construction and **SIPEX**—proprietary on-board charge pump circuitry to generate RS-232 signal-voltages, making them ideal for applications where +9V and -9V supplies are not available. The highly efficient charge pump is optimized to use small and inexpensive 0.1 $\mu$ F charge pump capacitors, saving board space and reducing overall circuit cost.

Each device provides a different driver/receiver combination to match standard application requirements. The **SP207E** is a 5-driver, 3-receiver device, ideal for DCE applications such as modems, printers or other peripherals. **SP208E** is a 4-driver/4-receiver device, ideal for providing handshaking signals in V.35 applications or other general-purpose serial communications. The **SP211E** and **SP213E** are each 3-driver, 5-receiver devices ideal for DTE serial ports on a PC or other data-terminal equipment.

The **SP211** and **SP213E** feature a low-power shutdown mode, which reduces power supply drain to 1 $\mu$ A. The **SP213E** includes a Wake-Up function which keeps two receivers active in the shutdown mode, unless disabled by the EN pin.

The family is available in 28 and 24 pin SO (wide) and SSOP (shrink) small outline packages. Devices can be specified for commercial (0°C to +70°C) and industrial/extended (-40°C to +85°C) operating temperatures.

## THEORY OF OPERATION

Sipex RS232 transceivers contain three basic circuit blocks — a) transmitter/driver, b) receiver and c) the **SIPEX**—proprietary charge pump. **SP211E** and **SP213E** also include SHUTDOWN and ENABLE functions.

## Transmitter/Drivers

The drivers are single-ended inverting transmitters, which accept either TTL or CMOS inputs and output the RS-232 signals with an inverted sense relative to the input logic levels. Should the input of the driver be left open, an internal pullup to  $V_{CC}$  forces the input high, thus committing the output to a logic-1 (MARK) state. The slew rate of the transmitter output is internally limited to a maximum of 30V/ $\mu$ s in order to meet the EIA/RS-232 and ITU V.28 standards. The transition of the output from high to low also meets the monotonicity requirements of the standard even when loaded. Driver output voltage swing is  $\pm 7V$  (typical) with no load, and  $\pm 5V$  or greater at maximum load. The transmitter outputs are protected against infinite short-circuits to ground without degradation in reliability.

The drivers of the **SP211E**, and **SP213E** can be tri-stated by using the SHUTDOWN function. In this “power-off” state the charge pump is turned off and  $V_{CC}$  current drops to 1 $\mu$ A typical. Driver output impedance will remain greater than 300 $\Omega$ , satisfying the RS-232 and V.28 specifications. For **SP211E** SHUTDOWN is active when pin 25 is driven high. For **SP213E** SHUTDOWN is active when pin 25 is driven low.

## Receivers

The receivers convert RS-232 level input signals to inverted TTL level signals. Because signals are often received from a transmission line where long cables and system interference can degrade signal quality, the inputs have enhanced sensitivity to detect weakened signals. The receivers also feature a typical hysteresis margin of 500mV for clean reception of slowly transitioning signals in noisy conditions. These enhancements ensure that the receiver is virtually immune to noisy transmission lines.

Receiver input thresholds are between 1.2 to 1.7 volts typical. This allows the receiver to detect standard TTL or CMOS logic-level signals as well as RS232 signals. If a receiver input is left unconnected or un-driven, a 5kΩ pulldown resistor to ground will commit the receiver to a logic-1 output state.

## HIGHLY EFFICIENT CHARGE-PUMP

The onboard dual-output charge pump is used to generate positive and negative signal voltages for the RS232 drivers. This enables fully compliant RS232 and V.28 signals from a single power supply device.

The charge pumps use four external capacitors to hold and transfer electrical charge. The **Sipex**-patented design (US Patent #5,306,954) uses a unique approach compared to older, less-efficient designs. The pumps use a four-phase voltage shifting technique to attain symmetrical V+ and V- power supplies. An intelligent control oscillator regulates the operation of the charge pump to maintain the proper voltages at maximum efficiency.

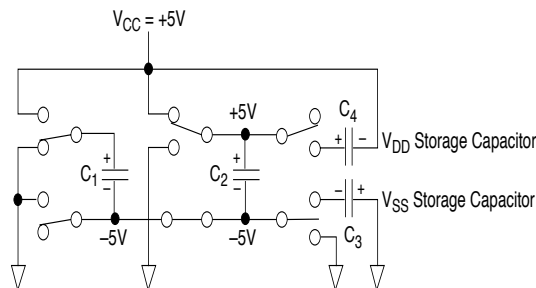

Figure 1. Charge Pump — Phase 1

### Phase 1

**V<sub>SS</sub> charge store and double:** The positive terminals of capacitors C<sub>1</sub> and C<sub>2</sub> are charged from V<sub>CC</sub> with their negative terminals initially connected to ground. C<sub>1</sub>+ is then connected to ground and the stored charge from C<sub>1</sub>- is superimposed onto C<sub>2</sub>-. Since C<sub>2</sub>+ is still connected to V<sub>CC</sub> the voltage potential across capacitor C<sub>2</sub> is now 2 x V<sub>CC</sub>.

### Phase 2

**V<sub>SS</sub> transfer and invert:** Phase two connects the negative terminal of C<sub>2</sub> to the V<sub>SS</sub> storage capacitor and the positive terminal of C<sub>2</sub> to ground. This transfers the doubled and inverted (V<sup>-</sup>) voltage onto C<sub>3</sub>. Meanwhile, capacitor C<sub>1</sub> charged from V<sub>CC</sub> to prepare it for its next phase.

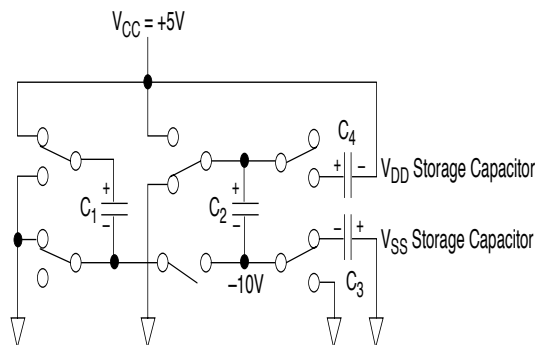

Figure 2. Charge Pump — Phase 2

### Phase 3

**V<sub>DD</sub> charge store and double:** Phase three is identical to the first phase. The positive terminals of capacitors C<sub>1</sub> and C<sub>2</sub> are charged from V<sub>CC</sub> with their negative terminals initially connected to ground. C<sub>1</sub>+ is then connected to ground and the stored charge from C<sub>1</sub>- is superimposed onto C<sub>2</sub>-. Since C<sub>2</sub>+ is still connected to V<sub>CC</sub> the voltage potential across capacitor C<sub>2</sub> is now 2 x V<sub>CC</sub>.

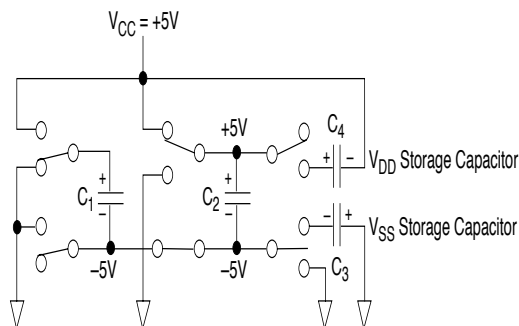

Figure 3. Charge Pump — Phase 3

#### Phase 4

— $V_{DD}$  transfer— The fourth phase connects the negative terminal of  $C_2$  to ground and the positive terminal of  $C_2$  to the  $V_{DD}$  storage capacitor. This transfers the doubled ( $V+$ ) voltage onto  $C_4$ . Meanwhile, capacitor  $C_1$  is charged from  $V_{CC}$  to prepare it for its next phase.

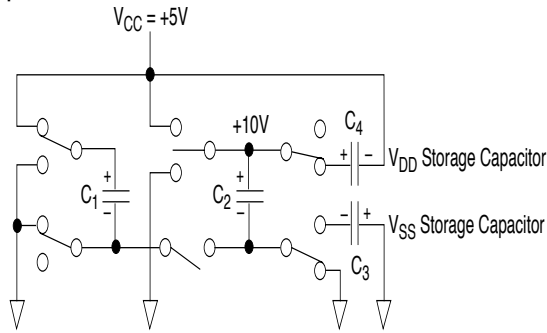

Figure 4. Charge Pump — Phase 4

The **Sipex** charge-pump generates  $V+$  and  $V-$  independently from  $V_{CC}$ . Hence in a no-load condition  $V+$  and  $V-$  will be symmetrical. Older charge pump approaches generate  $V+$  and then use part of that stored charge to generate  $V-$ . Because of inherent losses, the magnitude of  $V-$  will be smaller than  $V+$  on these older designs.

Under lightly loaded conditions the intelligent pump oscillator maximizes efficiency by running only as needed to maintain  $V+$  and  $V-$ . Since interface transceivers often spend much of their time at idle, this power-efficient innovation can greatly reduce total power

consumption. This improvement is made possible by the independent phase sequence of the Sipex charge-pump design.

The clock rate for the charge pump typically operates at greater than 15kHz, allowing the pump to run efficiently with small 0.1 $\mu$ F capacitors. Efficient operation depends on rapidly charging and discharging  $C_1$  and  $C_2$ , therefore capacitors should be mounted close to the IC and have low ESR (equivalent series resistance). Low cost surface mount ceramic capacitors (such as are widely used for power-supply decoupling) are ideal for use on the charge pump. However the charge pumps are designed to be able to function properly with a wide range of capacitor styles and values. If polarized capacitors are used, the positive and negative terminals should be connected as shown.

Voltage potential across any of the capacitors will never exceed  $2 \times V_{CC}$ . Therefore capacitors with working voltages as low as 10V rating may be used with a nominal  $V_{CC}$  supply.  $C_1$  will never see a potential greater than  $V_{CC}$ , so a working voltage of 6.3V is adequate. The reference terminal of the  $V_{DD}$  capacitor may be connected either to  $V_{CC}$  or ground, but if connected to ground a minimum 16V working voltage is required. Higher working voltages and/or capacitance values may be advised if operating at higher  $V_{CC}$  or to provide greater stability as the capacitors age.

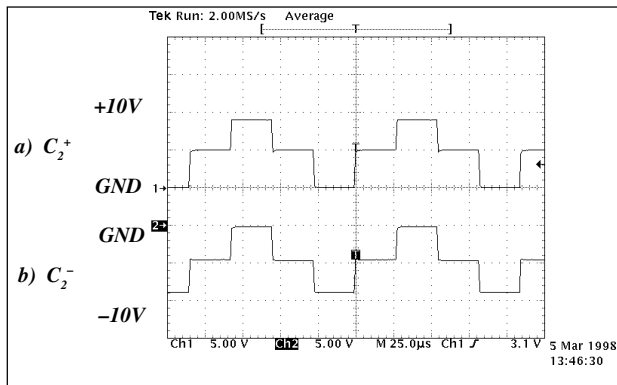

Figure 5: typical waveforms seen on capacitor  $C_2$  when all drivers are at maximum load.

## SHUTDOWN MODE

**SP211E** and **SP213E** feature a control input which will shut down the device and reduce the power supply current to less than  $10\mu\text{A}$ , making the parts ideal for battery-powered systems. In shutdown mode the transmitters will be tri-stated, the  $V^+$  output of the charge pump will discharge to  $V_{\text{CC}}$ , and the  $V^-$  output will discharge to ground. Shutdown will tri-state all receiver outputs of the **SP211E**.

## SP213E WAKEUP FUNCTION

On the **SP213E**, shutdown will tri-state receivers 1-3. Receivers 4 and 5 remain active to provide a “wake-up” function and may be used to monitor handshaking and control inputs for activity. With only two receivers active during shutdown, the **SP213E** draws only  $5\text{--}10\mu\text{A}$  of supply current.

A typical application of this function would be where a modem is interfaced to a computer in a power-down mode. The ring indicator signal from the modem could be passed through an active receiver in the **SP213E** that is itself in the shutdown mode. The ring indicator signal would propagate through the **SP213E** to the power management circuitry of the computer to power up the microprocessor and the **SP213E** drivers. After the supply voltage to the **SP213E** reaches  $+5.0\text{V}$ , the SHUTDOWN pin can be disabled, taking the **SP213E** out of the shutdown mode.

All receivers that are active during shutdown maintain  $500\text{mV}$  (typ.) of hysteresis. All receivers on the **SP213E** may be put into tri-state using the ENABLE pin.

## SHUTDOWN CONDITIONS

For complete shutdown to occur and the  $10\mu\text{A}$  power drain to be realized, the following conditions must be met:

### SP211E:

- $+5\text{V}$  must be applied to the SD pin
- ENABLE must be either Ground,  $+5.0\text{V}$  or not connected
- the transmitter inputs must be either  $+5.0\text{V}$  or not connected
- $V_{\text{CC}}$  must be  $+5\text{V}$
- Receiver inputs must be greater than Ground and less than  $+5\text{V}$

### SP213E:

- Zero Volts must be applied to the SD pin
- ENABLE must be either Ground,  $+5.0\text{V}$  or not connected
- The transmitter inputs must be either  $+5.0\text{V}$  or not connected
- $V_{\text{CC}}$  must be  $+5\text{V}$
- Receiver inputs must be greater than Ground and less than  $+5\text{V}$

## RECEIVER ENABLE

**SP211E** and **SP213E** feature an enable input, which allows the receiver outputs to be either tri-stated or enabled. This can be especially useful when the receiver is tied directly to a shared microprocessor data bus. For the **SP211E**, enable is active low; that is, Zero Volts applied to the ENABLE pin will enable the receiver outputs. For the **SP213E**, enable is active high; that is, +5V applied to the ENABLE pin will enable the receiver outputs.

Table 2. Shut-down and Wake-Up Truth Tables

SP211E			
SD	EN#	Drivers	Receivers
1	1	Active	Tri-State
1	0	Active	Active
0	1	Off	Tri-State
0	0	Off	Tri-State

SP213E				
SD#	EN	Drivers	Rx 1-3	Rx 4-5
1	1	Off	Tri-State	Active
1	0	Off	Tri-State	Tri-State
0	1	Active	Active	Active
0	0	Active	Tri-State	Tri-State

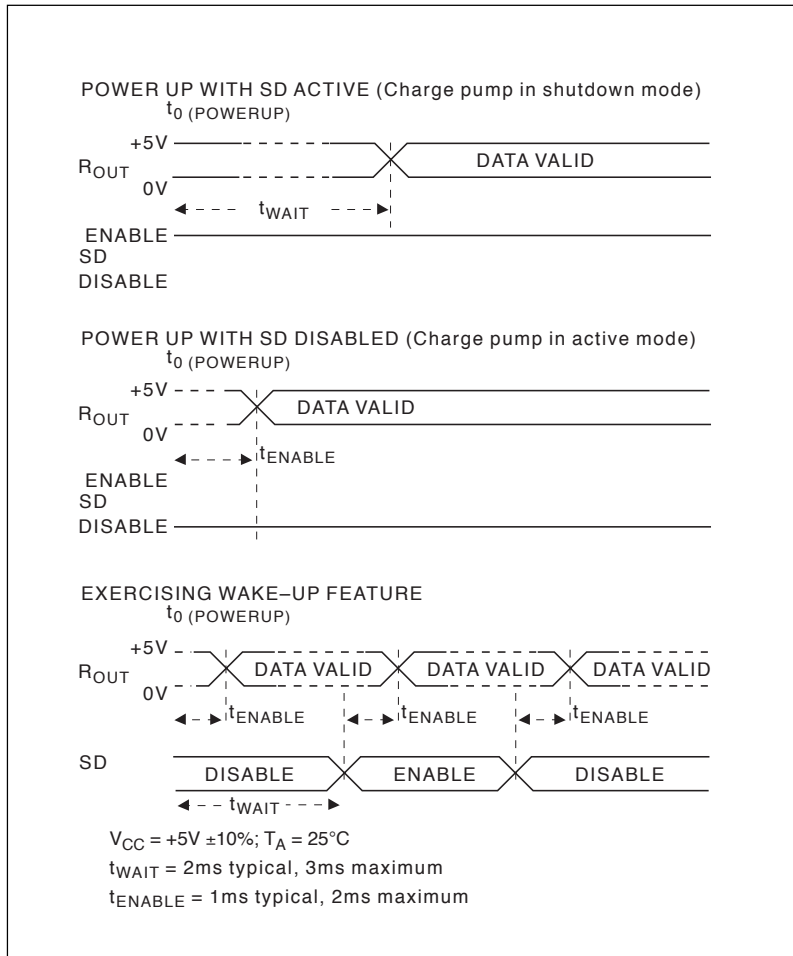

Figure 6. Wake-Up Timing

## ESD TOLERANCE

The SP207E Family incorporates ruggedized ESD cells on all driver output and receiver input pins. The ESD structure is improved over our previous family for more rugged applications and environments sensitive to electro-static discharges and associated transients. The improved ESD tolerance is at least  $\pm 15\text{kV}$  without damage nor latch-up.

There are different methods of ESD testing applied:

- a) MIL-STD-883, Method 3015.7
- b) IEC1000-4-2 Air-Discharge
- c) IEC1000-4-2 Direct Contact

The Human Body Model has been the generally accepted ESD testing method for semiconductors. This method is also specified in MIL-STD-883, Method 3015.7 for ESD testing. The premise of this ESD test is to simulate the human body's potential to store electro-static energy and discharge it to an integrated circuit. The simulation is performed by using a test model as shown in Figure 7. This method will test the IC's capability to withstand an ESD transient during normal handling such as in manufacturing areas where the ICs tend to be handled frequently.

The IEC-1000-4-2, formerly IEC801-2, is generally used for testing ESD on equipment and systems. For system manufacturers, they must guarantee a certain amount of ESD protection since the system itself is exposed to the outside environment and human presence. The premise with IEC1000-4-2 is that the system is required to withstand an amount of static electricity when ESD is applied to points and surfaces of the equipment that are accessible to personnel during normal usage. The transceiver IC receives most of the ESD current when the ESD source is applied to the connector pins. The test circuit for IEC1000-4-2 is shown on Figure 8. There are two methods within IEC1000-4-2, the Air Discharge method and the Contact Discharge method.

With the Air Discharge Method, an ESD voltage is applied to the equipment under test (EUT) through air. This simulates an electrically charged person ready to connect a cable onto the rear of the system only to find an unpleasant zap just before the person touches the back panel. The high energy potential on the person discharges through an arcing path to the rear panel of the system before he or she even touches the system. This energy, whether discharged directly or through air, is predominantly a

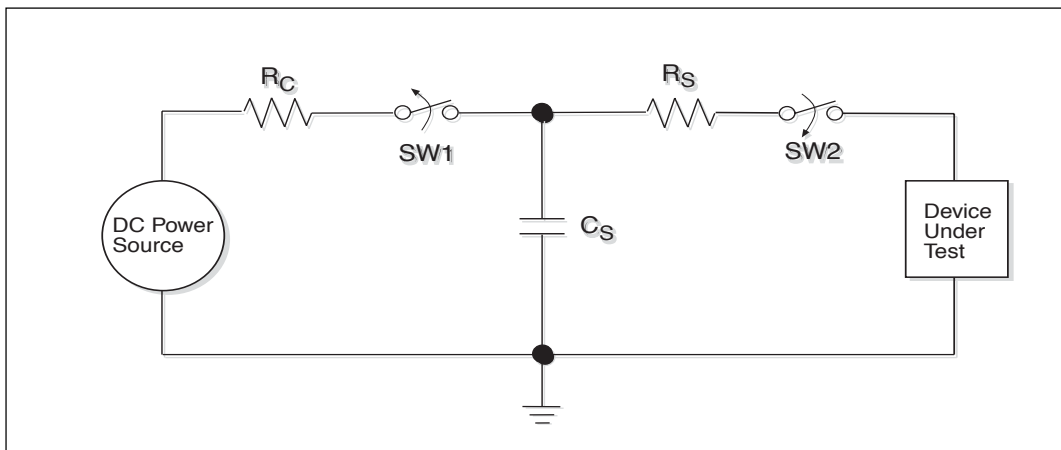

Figure 7. ESD Test Circuit for Human Body Model

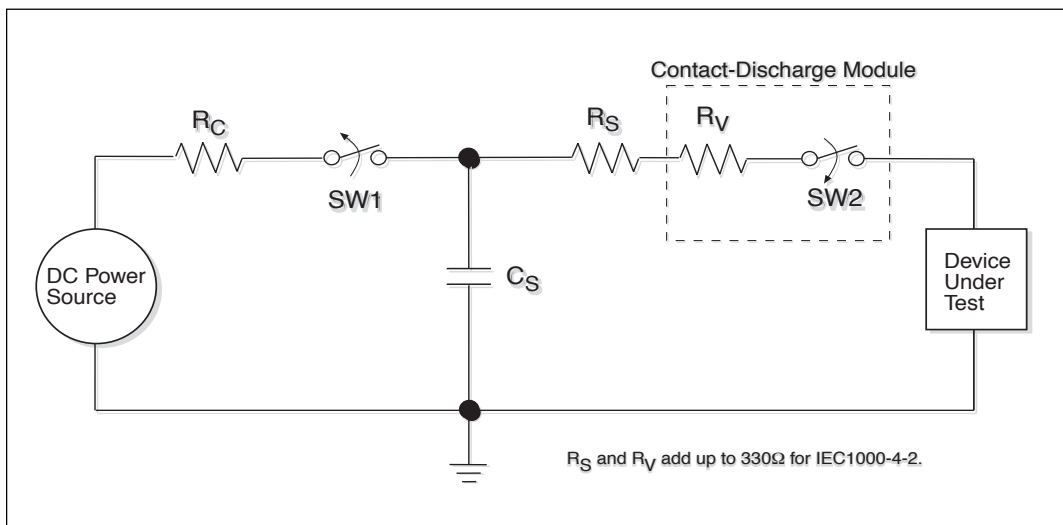

Figure 8. ESD Test Circuit for IEC1000-4-2

function of the discharge current rather than the discharge voltage. Variables with an air discharge such as approach speed of the object carrying the ESD potential to the system and humidity will tend to change the discharge current. For example, the rise time of the discharge current varies with the approach speed.

The Contact Discharge Method applies the ESD current directly to the EUT. This method was devised to reduce the unpredictability of the ESD arc. The discharge current rise time is constant since the energy is directly transferred without the air-gap arc. In situations such as hand held systems, the ESD charge can be directly discharged to the equipment from a person already holding the equipment. The current is transferred on to the keypad or the serial port of the equipment directly and then travels through the PCB and finally to the IC.

The circuit model in Figures 7 and 8 represent the typical ESD testing circuit used for all three methods. The  $C_S$  is initially charged with the DC power supply when the first switch (SW1) is on. Now that the capacitor is charged, the second switch (SW2) is on while SW1 switches off. The voltage stored

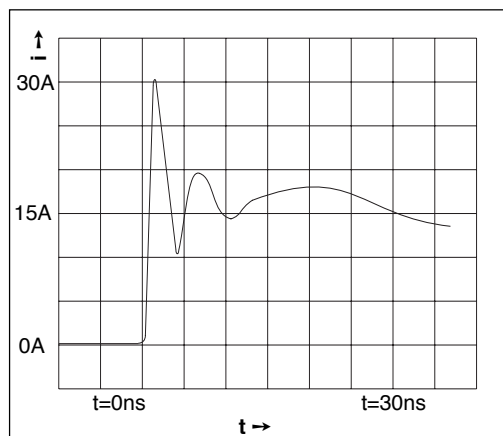

Figure 9. ESD Test Waveform for IEC1000-4-2

in the capacitor is then applied through  $R_S$ , the current limiting resistor, onto the device under test (DUT). In ESD tests, the SW2 switch is pulsed so that the device under test receives a duration of voltage.

For the Human Body Model, the current limiting resistor ( $R_S$ ) and the source capacitor ( $C_S$ ) are 1.5kW and 100pF, respectively. For IEC-1000-4-2, the current limiting resistor ( $R_S$ ) and the source capacitor ( $C_S$ ) are 330W and 150pF, respectively.

The higher  $C_S$  value and lower  $R_S$  value in the IEC1000-4-2 model are more stringent

than the Human Body Model. The larger storage capacitor injects a higher voltage to the test point when SW2 is switched on. The lower current limiting resistor increases the current charge onto the test point.

## EIA STANDARDS

The Electronic Industry Association (EIA) developed several standards of data transmission which are revised and updated in order to meet the requirements of the industry. In data processing, there are two basic means of communicating between systems and components. The RS-232 standard was first introduced in 1962 and, since that time, has become an industry standard.

DEVICE PIN TESTED	HUMAN BODY MODEL	IEC1000-4-2		
		Air Discharge	Direct Contact	Level
Driver Outputs	$\pm 15\text{kV}$	$\pm 15\text{kV}$	$\pm 8\text{kV}$	4
Receiver Inputs	$\pm 15\text{kV}$	$\pm 15\text{kV}$	$\pm 8\text{kV}$	4

Table 3. Transceiver ESD Tolerance Levels

Specification	RS-232D	RS-423A	RS-422	RS-485	RS-562
Mode of Operation	Single-Ended	Single-Ended	Differential	Differential	Single-Ended
No. of Drivers and Receivers Allowed on One Line	1 Driver 1 Receiver	1 Driver 10 Receivers	1 Driver 10 Receivers	32 Drivers 32 Receivers	1 Driver 1 Receiver
Maximum Cable Length	50 feet	4,000 feet	4,000 feet	4,000 feet	$C \leq 2,500\text{pF}$ @ $<20\text{Kbps}$ ; $C \leq 1,000\text{pF}$ @ $>20\text{Kbps}$
Maximum Data Rate	20Kb/s	100Kb/s	10Mb/s	10Mb/s	64Kb/s
Driver output Maximum Voltage	$\pm 25\text{V}$	$\pm 6\text{V}$	$-0.25\text{V}$ to $+6\text{V}$	$-7\text{V}$ to $+12\text{V}$	$-3.7\text{V}$ to $+13.2\text{V}$
Driver Output Signal Level Loaded Unloaded	$\pm 5\text{V}$ $\pm 15\text{V}$	$\pm 3.6\text{V}$ $\pm 6\text{V}$	$\pm 2\text{V}$ $\pm 5\text{V}$	$\pm 1.5\text{V}$ $\pm 5\text{V}$	$\pm 3.7\text{V}$ $\pm 13.2\text{V}$
Driver Load Impedance	3 – 7Kohm	450 ohm	100 ohm	54 ohm	3–7Kohm
Max. Driver Output Current (High Impedance State) Power On Power Off	$V_{\text{MAX}}/300$	100 $\mu\text{A}$	$\pm 100\mu\text{A}$	$\pm 100\mu\text{A}$ $\pm 100\mu\text{A}$	
Slew Rate	30V/ $\mu\text{s}$ max.	Controls Provided			30V/ $\mu\text{s}$ max.
Receiver Input Voltage Range	$\pm 15\text{V}$	$\pm 12\text{V}$	$-7\text{V}$ to $+7\text{V}$	$-7\text{V}$ to $+12\text{V}$	$\pm 15\text{V}$
Receiver Input Sensitivity	$\pm 3\text{V}$	$\pm 200\text{mV}$	$\pm 200\text{mV}$	$\pm 200\text{mV}$	$\pm 3\text{V}$
Receiver Input Resistance	3–7Kohm	4Kohm min.	4Kohm min.	12Kohm min.	3–7Kohm

Table 4. EIA Standard Definitions

TYPICAL APPLICATION CIRCUITS...SP207E TO SP213E

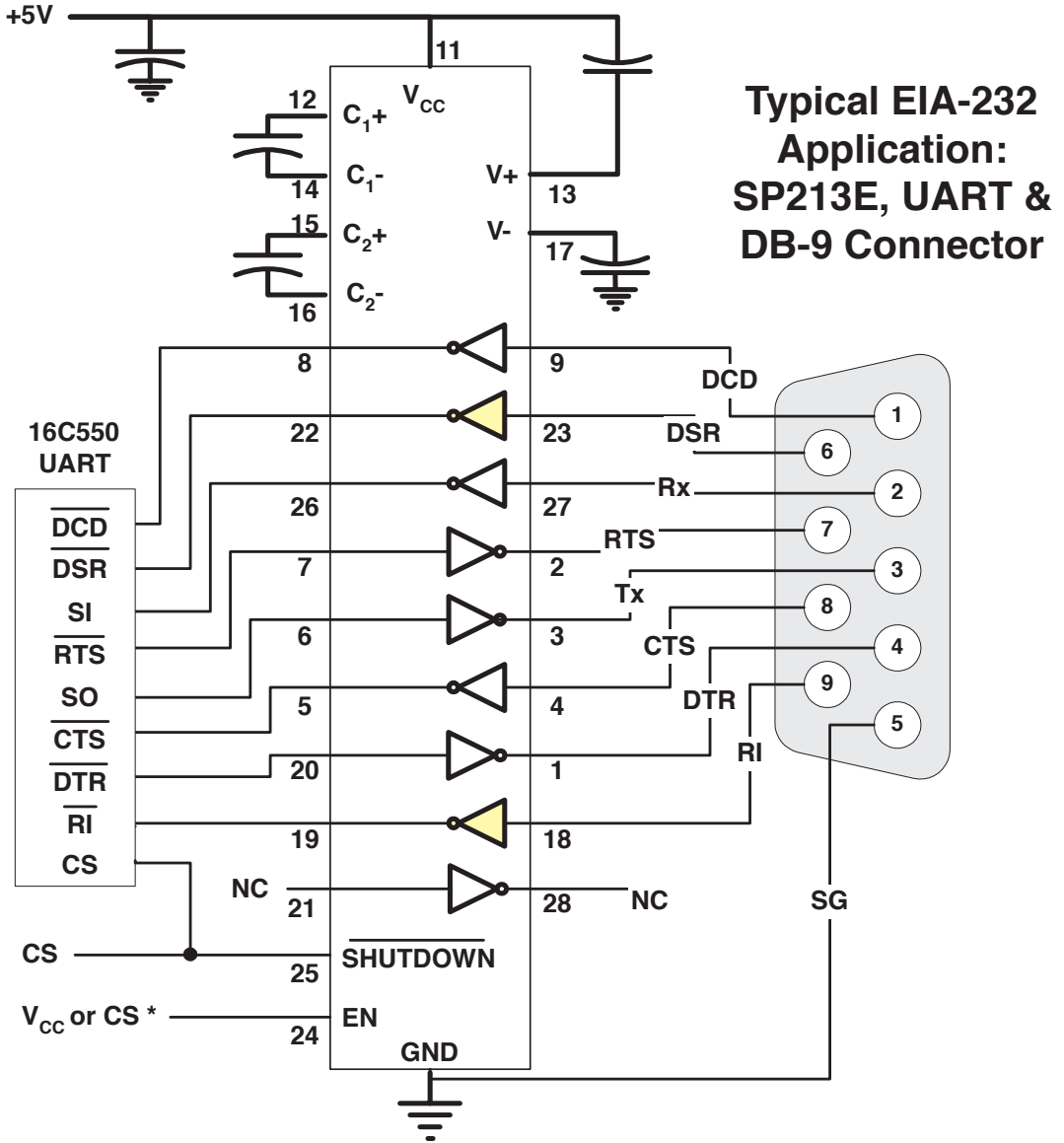
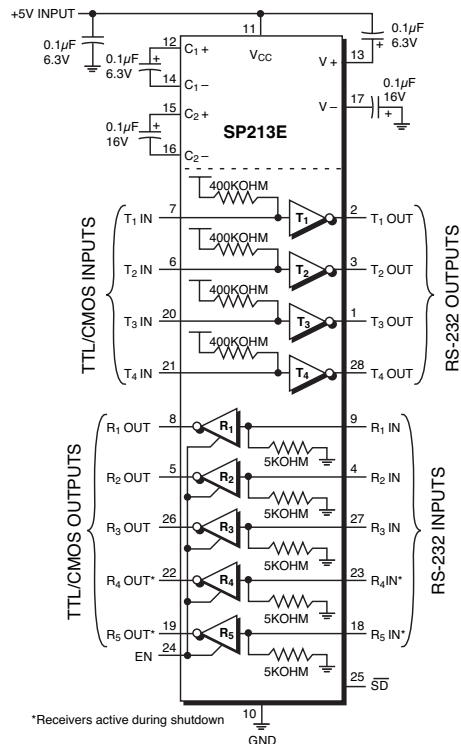
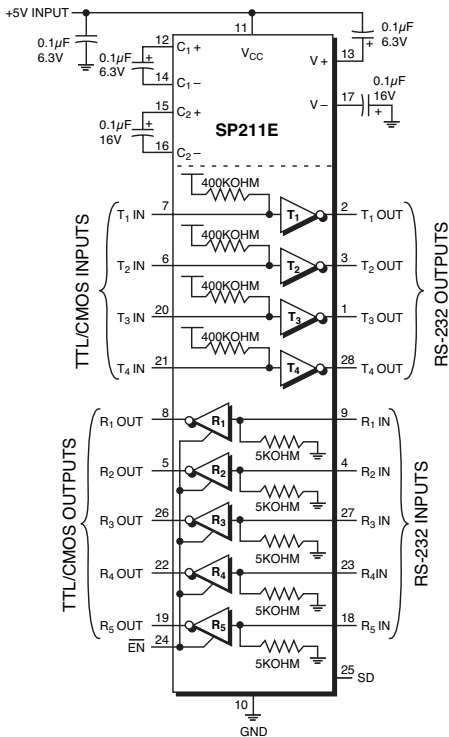
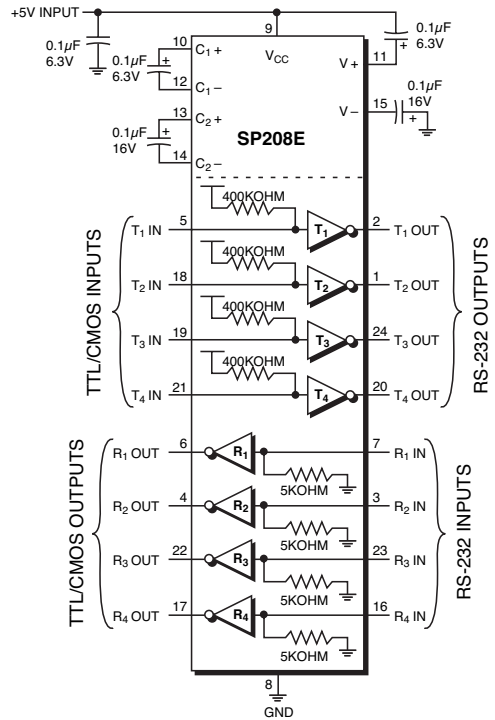
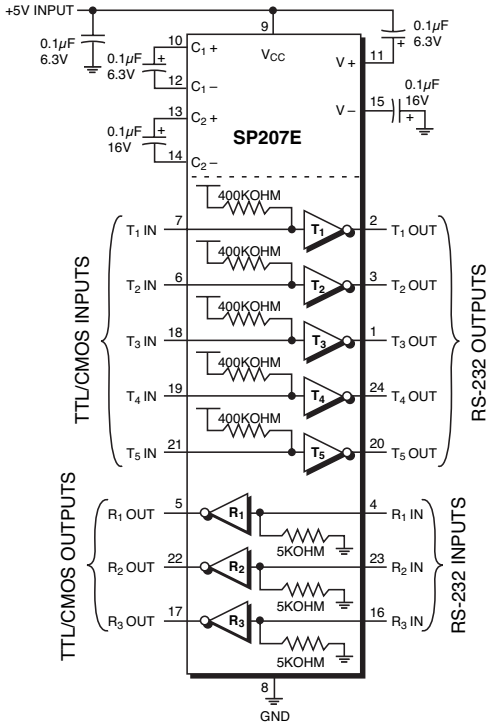
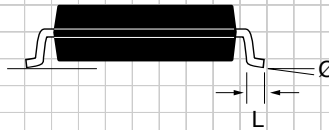
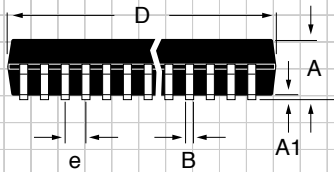
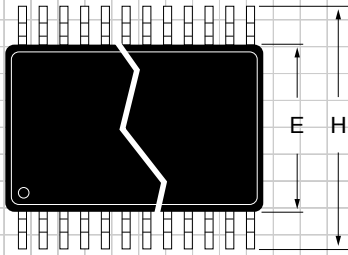

Figure 10. Typical SP213E Application

# TYPICAL APPLICATION CIRCUITS...SP207E TO SP213E



**PACKAGE: PLASTIC SHRINK  
SMALL OUTLINE  
(SSOP)**



DIMENSIONS (Inches) Minimum/Maximum (mm)	24-PIN	28-PIN
A	0.068/0.078 (1.73/1.99)	0.068/0.078 (1.73/1.99)
A1	0.002/0.008 (0.05/0.21)	0.002/0.008 (0.05/0.21)
B	0.010/0.015 (0.25/0.38)	0.010/0.015 (0.25/0.38)
D	0.317/0.328 (8.07/8.33)	0.397/0.407 (10.07/10.33)
E	0.205/0.212 (5.20/5.38)	0.205/0.212 (5.20/5.38)
e	0.0256 BSC (0.65 BSC)	0.0256 BSC (0.65 BSC)
H	0.301/0.311 (7.65/7.90)	0.301/0.311 (7.65/7.90)
L	0.022/0.037 (0.55/0.95)	0.022/0.037 (0.55/0.95)
Ø	0°/8° (0°/8°)	0°/8° (0°/8°)

**PACKAGE: PLASTIC  
SMALL OUTLINE (SOIC)  
(WIDE)**

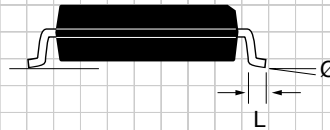
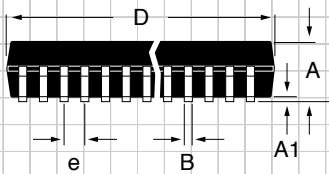
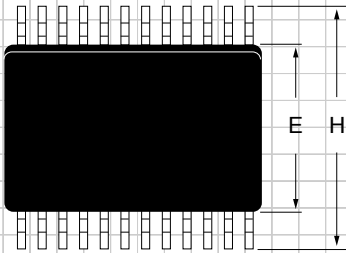

DIMENSIONS (Inches) Minimum/Maximum (mm)	24-PIN	28-PIN
A	0.093/0.104 (2.352/2.649)	0.093/0.104 (2.352/2.649)
A1	0.004/0.012 (0.102/0.300)	0.004/0.012 (0.102/0.300)
B	0.013/0.020 (0.330/0.508)	0.013/0.020 (0.330/0.508)
D	0.599/0.614 (15.20/15.59)	0.697/0.713 (17.70/18.09)
E	0.291/0.299 (7.402/7.600)	0.291/0.299 (7.402/7.600)
e	0.050 BSC (1.270 BSC)	0.050 BSC (1.270 BSC)
H	0.394/0.419 (10.00/10.64)	0.394/0.419 (10.00/10.64)
L	0.016/0.050 (0.406/1.270)	0.016/0.050 (0.406/1.270)
Ø	0°/8° (0°/8°)	0°/8° (0°/8°)

# PACKAGE: PLASTIC DUAL-IN-LINE (NARROW)

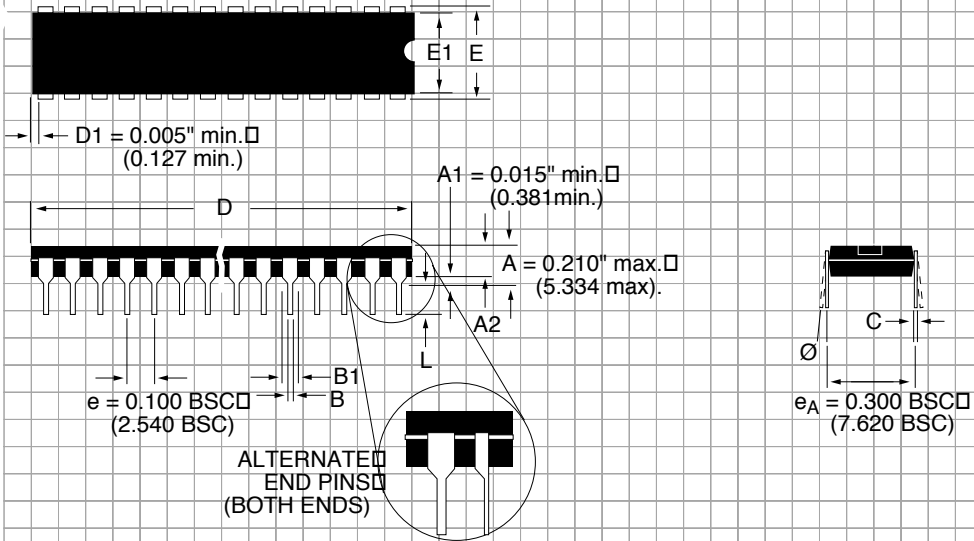

DIMENSIONS (Inches) Minimum/Maximum (mm)	24-PIN
A2	0.115/0.195 (2.921/4.953)
B	0.014/0.022 (0.356/0.559)
B1	0.045/0.070 (1.143/1.778)
C	0.008/0.014 (0.203/0.356)
D	1.230/1.280 (31.24/32.51)
E	0.300/0.325 (7.620/8.255)
E1	0.240/0.280 (6.096/7.112)
L	0.115/0.150 (2.921/3.810)
$\emptyset$	0°/ 15° (0°/15°)

## ORDERING INFORMATION

### RS232 Transceivers:

Model	Drivers	Receivers	Temperature Range	Package Type
SP207ECA	5	3	0°C to +70°C	24-pin SSOP
SP207ECP	5	3	0°C to +70°C	24-pin Plastic DIP
SP207ECT	5	3	0°C to +70°C	24-pin SOIC
SP207EEA	5	3	-40°C to +85°C	24-pin SSOP
SP207EEP	5	3	-40°C to +85°C	24-pin Plastic DIP
SP207EET	5	3	-40°C to +85°C	24-pin SOIC
SP208ECA	4	4	0°C to +70°C	24-pin SSOP
SP208ECP	4	4	0°C to +70°C	24-pin Plastic DIP
SP208ECT	4	4	0°C to +70°C	24-pin SOIC
SP208EEA	4	4	-40°C to +85°C	24-pin SSOP
SP208EEP	4	4	-40°C to +85°C	24-pin Plastic DIP
SP208EET	4	4	-40°C to +85°C	24-pin SOIC

### RS232 Transceivers with Low-Power Shutdown and Tri-state Enable:

Model	Drivers	Receivers	Temperature Range	Package Type
SP211ECA	4	5	0°C to +70°C	28-pin SSOP
SP211ECT	4	5	0°C to +70°C	28-pin SOIC
SP211EEA	4	5	-40°C to +85°C	28-pin SSOP
SP211EET	4	5	-40°C to +85°C	28-pin SOIC

### RS232 Transceivers with Low-Power Shutdown, Tri-state Enable, and Wake-Up Function:

Model	Drivers	Receivers	Temperature Range	Package Type
SP213ECA	4	5, with 2 active in Shutdown	0°C to +70°C	28-pin SSOP
SP213ECT	4	5, with 2 active in Shutdown	0°C to +70°C	28-pin SOIC
SP213EEA	4	5, with 2 active in Shutdown	-40°C to +85°C	28-pin SSOP
SP213EET	4	5, with 2 active in Shutdown	-40°C to +85°C	28-pin SOIC

Please consult the factory for pricing and availability on a Tape-On-Reel option.

Available in lead free packaging. To order add "-L" suffix to part number.

Example: SP213EET/TR = standard; SP213EET-L/TR = lead free.

/TR = Tape and Reel



## SIGNAL PROCESSING EXCELLENCE

Sipex Corporation

### Headquarters and Sales Office

233 South Hillview Drive  
 Milpitas, CA 95035  
 TEL: (408) 934-7500  
 FAX: (408) 935-7600

Sipex Corporation reserves the right to make changes to any products described herein. Sipex does not assume any liability arising out of the application or use of any product or circuit described hereing; neither does it convey any license under its patent rights nor the rights of others.