

PROTECTION PRODUCTS

Description

The SMDAxxC series of TVS arrays are designed to provide bidirectional protection for sensitive electronics from damage or latch-up due to ESD, lightning and other voltage-induced transient events. Each device will protect four data or I/O lines. They are available with operating voltages of 5V, 12V, 15V and 24V.

TVS diodes are solid-state devices designed specifically for transient suppression. They offer desirable characteristics for board level protection including fast response time, low operating and clamping voltage and no device degradation. The low profile SO-8 package allows the user to protect up to four independent lines with one package. The SMDAxxC series is suitable protection for sensitive semiconductor components such as microprocessors, ASICs, transceivers, transducers, and CMOS memory.

The SMDAxxC series devices may be used to meet the ESD immunity requirements of IEC 61000-4-2, level 4 for air and contact discharge.

Features

- ◆ Transient protection for data lines to IEC 61000-4-2 (ESD) $\pm 15\text{kV}$ (air), $\pm 8\text{kV}$ (contact)
IEC 61000-4-4 (EFT) 40A (5/50ns)
IEC 61000-4-5 (Lightning) 12A (8/20 μs)
- ◆ Bidirectional protection
- ◆ Small SO-8 package
- ◆ Protects four I/O lines
- ◆ Working voltages: 5V, 12V, 15V and 24V
- ◆ Low leakage current
- ◆ Low operating and clamping voltages
- ◆ Solid-state silicon avalanche technology

Mechanical Characteristics

- ◆ JEDEC SO-8 package
- ◆ Molding compound flammability rating: UL 94V-0
- ◆ Marking : Part number, date code, logo
- ◆ Packaging : Tube or Tape and Reel per EIA 481

Applications

- ◆ Data and I/O Lines
- ◆ Microprocessor based equipment
- ◆ Notebooks, Desktops, and Servers
- ◆ Instrumentation
- ◆ LAN/WAN equipment
- ◆ Peripherals
- ◆ Serial and Parallel Ports

Schematic & PIN Configuration

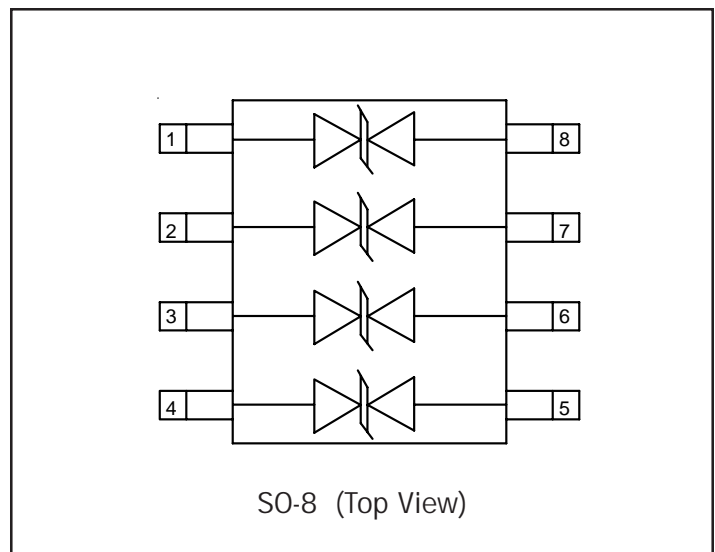

PROTECTION PRODUCTS

Absolute Maximum Rating

Rating	Symbol	Value	Units
Peak Pulse Power (tp = 8/20μs)	P_{pk}	300	Watts
ESD Voltage (HBM per IEC 61000-4-2)	V_{ESD}	>25	kV
Lead Soldering Temperature	T_L	260 (10 sec.)	°C
Operating Temperature	T_J	-55 to +125	°C
Storage Temperature	T_{STG}	-55 to +150	°C

Electrical Characteristics

SMDA05C						
Parameter	Symbol	Conditions	Minimum	Typical	Maximum	Units
Reverse Stand-Off Voltage	V_{RWM}				5	V
Reverse Breakdown Voltage	V_{BR}	$I_t = 1mA$	6			V
Reverse Leakage Current	I_R	$V_{RWM} = 5V, T=25^{\circ}C$			20	μA
Clamping Voltage	V_C	$I_{PP} = 1A, tp = 8/20\mu s$			9.8	V
Clamping Voltage	V_C	$I_{PP} = 5A, tp = 8/20\mu s$			11	V
Maximum Peak Pulse Current	I_{PP}	$tp = 8/20\mu s$			17	A
Junction Capacitance	C_J	$V_R = 0V, f = 1MHz$			350	pF

SMDA12C						
Parameter	Symbol	Conditions	Minimum	Typical	Maximum	Units
Reverse Stand-Off Voltage	V_{RWM}				12	V
Reverse Breakdown Voltage	V_{BR}	$I_t = 1mA$	13.3			V
Reverse Leakage Current	I_R	$V_{RWM} = 12V, T=25^{\circ}C$			1	μA
Clamping Voltage	V_C	$I_{PP} = 1A, tp = 8/20\mu s$			19	V
Clamping Voltage	V_C	$I_{PP} = 5A, tp = 8/20\mu s$			24	V
Maximum Peak Pulse Current	I_{PP}	$tp = 8/20\mu s$			12	A
Junction Capacitance	C_J	$V_R = 0V, f = 1MHz$			120	pF

PROTECTION PRODUCTS

Electrical Characteristics (Continued)

SMDA15C						
Parameter	Symbol	Conditions	Minimum	Typical	Maximum	Units
Reverse Stand-Off Voltage	V_{RWM}				15	V
Reverse Breakdown Voltage	V_{BR}	$I_t = 1\text{mA}$	16.7			V
Reverse Leakage Current	I_R	$V_{RWM} = 15\text{V}, T=25^\circ\text{C}$			1	μA
Clamping Voltage	V_C	$I_{PP} = 1\text{A}, t_p = 8/20\mu\text{s}$			24	V
Clamping Voltage	V_C	$I_{PP} = 5\text{A}, t_p = 8/20\mu\text{s}$			30	V
Maximum Peak Pulse Current	I_{PP}	$t_p = 8/20\mu\text{s}$			10	A
Junction Capacitance	C_J	$V_R = 0\text{V}, f = 1\text{MHz}$			75	pF

SMDA24C						
Parameter	Symbol	Conditions	Minimum	Typical	Maximum	Units
Reverse Stand-Off Voltage	V_{RWM}				24	V
Reverse Breakdown Voltage	V_{BR}	$I_t = 1\text{mA}$	26.7			V
Reverse Leakage Current	I_R	$V_{RWM} = 24\text{V}, T=25^\circ\text{C}$			1	μA
Clamping Voltage	V_C	$I_{PP} = 1\text{A}, t_p = 8/20\mu\text{s}$			43	V
Clamping Voltage	V_C	$I_{PP} = 5\text{A}, t_p = 8/20\mu\text{s}$			55	V
Maximum Peak Pulse Current	I_{PP}	$t_p = 8/20\mu\text{s}$			5	A
Junction Capacitance	C_J	$V_R = 0\text{V}, f = 1\text{MHz}$			50	pF

PROTECTION PRODUCTS

Typical Characteristics

Non-Repetitive Peak Pulse Power vs. Pulse Time

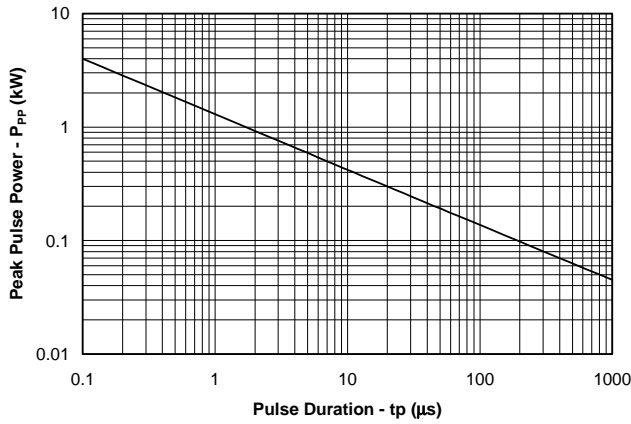

Power Derating Curve

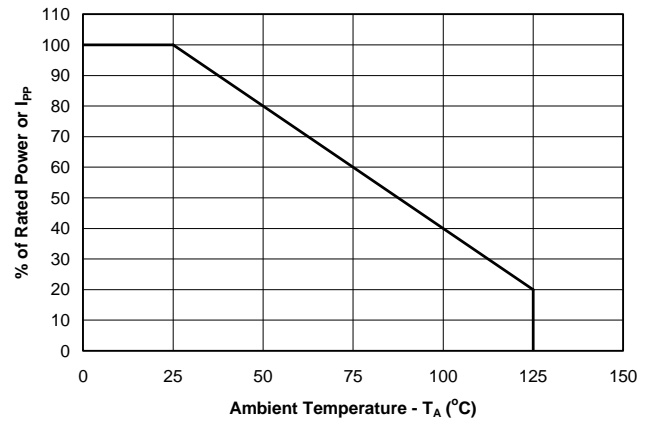

Pulse Waveform

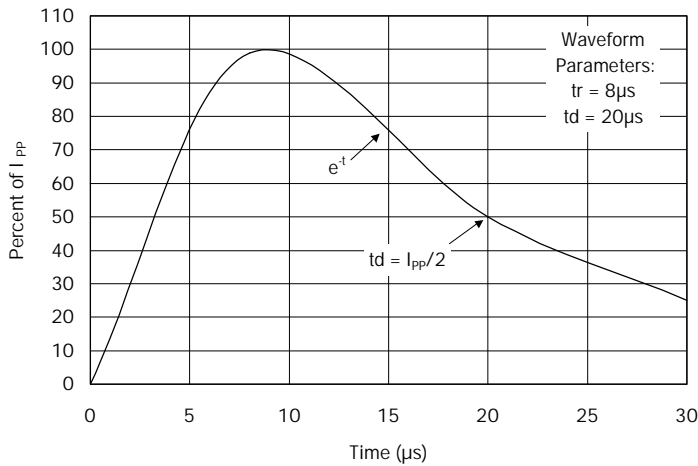

ESD Pulse Waveform (IEC 61000-4-2)

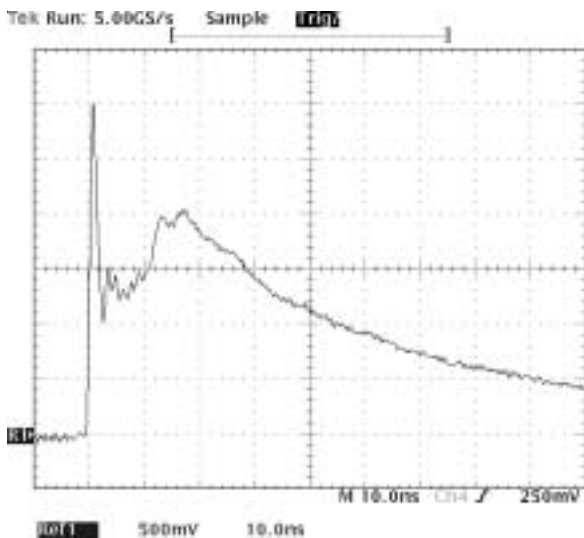

IEC 61000-4-2 Discharge Parameters

Level	First Peak Current (A)	Peak Current at 30 ns (A)	Peak Current at 60 ns (A)	Test Voltage (Contact Discharge) (kV)	Test Voltage (Air Discharge) (kV)
1	7.5	4	8	2	2
2	15	8	4	4	4
3	22.5	12	6	6	8
4	30	16	8	8	15

PROTECTION PRODUCTS

Applications Information

Device Connection for Protection of Four Data Lines

The SMDAxxC series devices are designed to protect up to four data lines. The devices are connected as follows:

- The SMDAxxC are bidirectional devices and are designed for use on lines where the normal operating voltage is above and below ground. Pins 1, 2, 3, and 4 are connected to the protected lines. Pins 5, 6, 7, and 8 are connected to ground. Since the device is electrically symmetrical, these connections may be reversed. The ground connections should be made directly to the ground plane for best results. The path length is kept as short as possible to reduce the effects of parasitic inductance in the board traces.

Circuit Board Layout Recommendations for Suppression of ESD.

Good circuit board layout is critical for the suppression of ESD induced transients. The following guidelines are recommended:

- Place the TVS near the input terminals or connectors to restrict transient coupling.
- Minimize the path length between the TVS and the protected line.
- Minimize all conductive loops including power and ground loops.
- The ESD transient return path to ground should be kept as short as possible.
- Never run critical signals near board edges.
- Use ground planes whenever possible.

Circuit Diagram

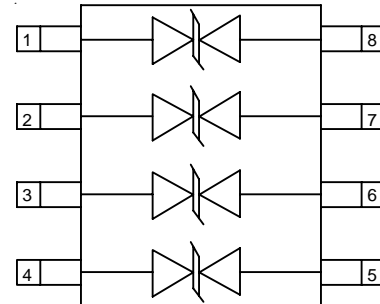

I/O Line Protection

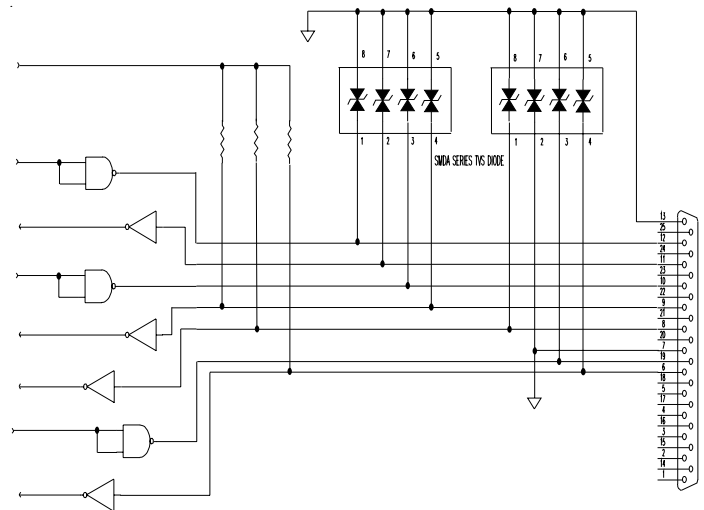

Typical Connection

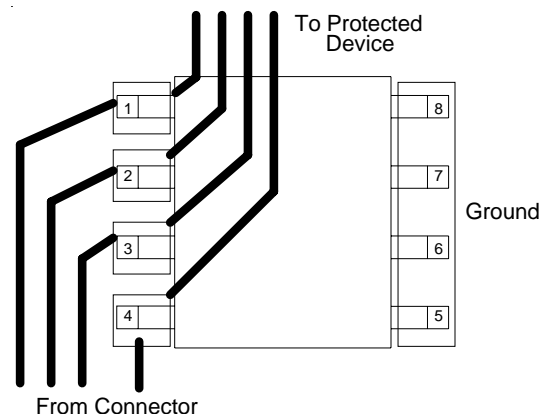

PROTECTION PRODUCTS

Outline Drawing - S0-8

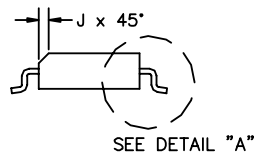
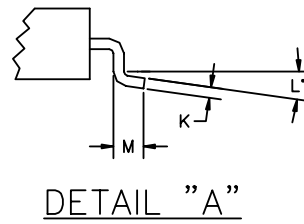
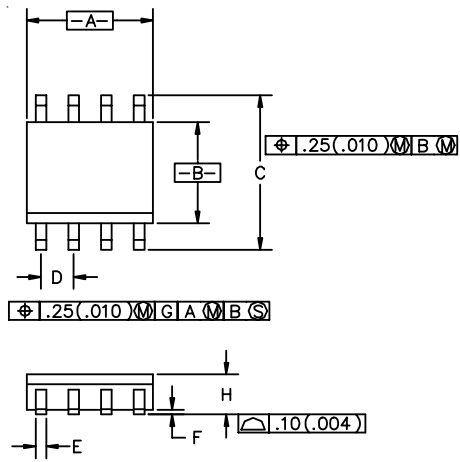

DIM ^N	INCHES		MM		NOTE
	MIN	MAX	MIN	MAX	
A	.188	.197	4.80	5.00	
B	.149	.158	3.80	4.00	
C	.228	.244	5.80	6.20	
D	.050 BSC		1.27 BSC		
E	.013	.020	0.33	0.51	
F	.004	.010	0.10	0.25	
H	.053	.069	1.35	1.75	
J	.011	.019	0.28	0.48	
K	.007	.010	.19	.25	
L	0°	8°	0°	8°	
M	.016	.050	0.40	1.27	

Land Pattern - S0-8

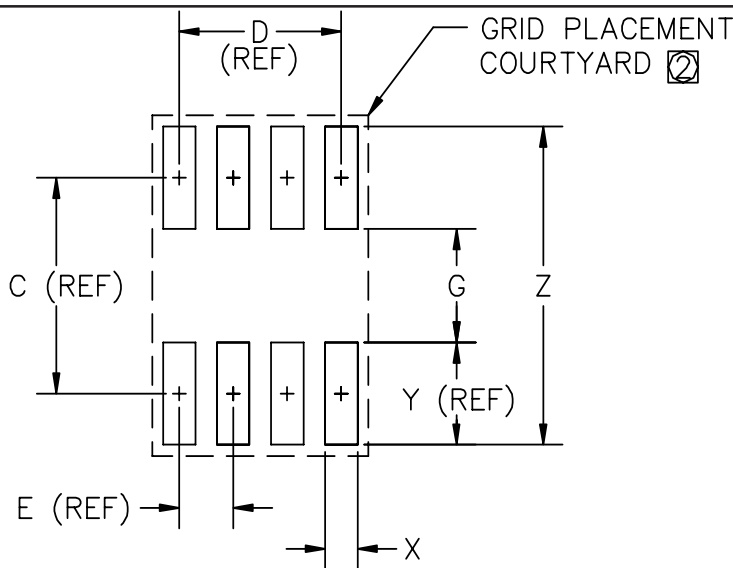

DIM ^N	INCHES		MM		NOTE
	MIN	MAX	MIN	MAX	
C	—	.19	—	5.00	—
D	—	.15	—	3.81	—
E	—	.05	—	1.27	—
G	.10	.11	2.60	2.80	—
X	.02	.03	.60	.80	—
Y	—	.09	—	2.40	—
Z	—	.29	7.20	7.40	—

Ⓜ GRID PLACEMENT COURTYARD IS 12x16 ELEMENTS (6 mm X 8mm) IN ACCORDANCE WITH THE INTERNATIONAL GRID DETAILED IN IEC PUBLICATION 97.

Ⓛ CONTROLLING DIMENSION: MILLIMETERS

PROTECTION PRODUCTS**Ordering Information**

Part Number	Working Voltage	Qty per Reel	Reel Size
SMDA05C.TB	5V	500	7 Inch
SMDA12C.TB	12V	500	7 Inch
SMDA15C.TB	15V	500	7 Inch
SMDA24C.TB	24V	500	7 Inch

Note:

- (1) No suffix indicates tube pack.
- (2) Consult factory for availability of 13 Inch reels.

Contact Information

Semtech Corporation
Protection Products Division
200 Flynn Road, Camarillo, CA 93012
Phone: (805)498-2111 FAX (805)498-3804