

# SKiiP 25ACI12T4V2

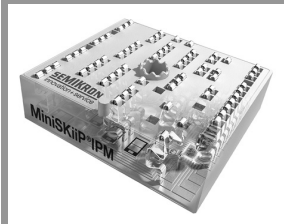

MiniSKiiP® AC IPM

Three-phase inverter intelligent power module

## SKiiP 25ACI12T4V2

Data sheet status: preliminary

### Features

- One screw assembly of driver, module and heat sink
- Solder-free assembly of power, control and auxiliary contacts
- Trench-Field-Stop IGBT
- Robust and soft freewheeling diodes in CAL technology
- Latch-up free SOI driver IC
- Advanced level shifter technology
- Bootstrap power supply technology
- Matched propagation delay for all channels
- Overcurrent shut-down via current sensing
- Interlock logic for shoot-through prevention
- Common shut-down signal
- Undervoltage lockout for all channels with hysteresis band
- Integrated temperature sensor (NTC)
- RoHS compliant

### Typical Applications

- Industrial- & consumer drives
- Power supplies (SMPS & UPS)
- Industrial air conditioner

### Remarks

### Absolute Maximum Ratings ( $T_s=25^\circ\text{C}$ , unless otherwise specified)

Symbol	Parameter	Conditions	Values	Units
<b>IGBT - Inverter</b>				
$V_{CES}$			1200	V
$I_C$	$T_j = 175^\circ\text{C}$	$T_s = 25^\circ\text{C}$	61	A
		$T_s = 70^\circ\text{C}$	50	A
$I_{Cnom}$			50	A
$I_{CRM}$	$I_{CRM} = 3 \times I_{Cnom}$		150	A
$t_{psc}$	$V_{CC} = 600\text{V}$	$T_j = 150^\circ\text{C}$	$\leq 10$	$\mu\text{s}$
$T_{j(max)}$	Junction temperature		-40 ... +175	$^\circ\text{C}$
<b>Diode</b>				
$I_F$	$T_j = 175^\circ\text{C}$	$T_s = 25^\circ\text{C}$	57	A
		$T_s = 70^\circ\text{C}$	45	A
$I_{Fnom}$			50	A
$I_{FRM}$	$I_{FRM} = 3 \times I_{Cnom}$	$T_j < T_{j(max)}$	150	A
$I_{FSM}$	$t_p = 10\text{ ms, sin } 180^\circ, T_j = 150^\circ\text{C}$		265	A
$T_{j(max)}$	Junction temperature		-40 ... +175	$^\circ\text{C}$
<b>Driver</b>				
VCC	Applied between VCC-VSS, VCCL-VSSL		17	V
VBX	Applied between VB1-U, VB2-V, VB3-W		17	V
Vsx	Voltage to VSS, $t_p < 500\text{ns}$		-3 ... 1200	V
$V_{in}$	Applied between HIN1, LIN1, HIN2, LIN2, HIN3, LIN3 - VSS		VSS-0.3 ... VCC+0.3	
$V_{oErr}$	Applied between /ERROUT-VSS		VSS-0.3 ... VCC+0.3	V
$I_{max(EO)}$	Between /ERROUT-VSS		10	mA
$V_{ITRIP}$	Applied between ITRIP-VSS		VSS-0.3 ... VCC+0.3	V
$f_{max}$			20	kHz
<b>Temperature</b>				
$T_c$			-40 ... +125	$^\circ\text{C}$
$T_{stg}$			-40 ... +125	$^\circ\text{C}$
<b>System</b>				
$V_{isol}$		AC, rms, f=60Hz, t=1min, all pins to heat sink	2500	V
$I_{RMS}$		Per power terminal (20A / Spring)	20	A

### Electrical Characteristics ( $T_s=25^\circ\text{C}$ , unless otherwise specified)

Symbol	Parameter	Conditions	Limits			Units
			min.	typ.	max.	
<b>IGBT</b>						
$V_{CESat}$	$I_C = 50\text{ A}$	$T_j = 25^\circ\text{C}$	1.85	2.05		V
	$V_{GE} = 15\text{ V}$	$T_j = 150^\circ\text{C}$	2.25	2.45		V
$V_{CEO}$		$T_j = 25^\circ\text{C}$	0.8	0.9		V
		$T_j = 150^\circ\text{C}$	0.7	0.8		V
$r_{GE}$	$V_{GE} = 15\text{ V}$	$T_j = 25^\circ\text{C}$	21	23		$\text{m}\Omega$
		$T_j = 150^\circ\text{C}$	31	33		$\text{m}\Omega$
$I_{CES}$	$V_{GE} = 0\text{ V}$	$T_j = 25^\circ\text{C}$			0.3	mA
	$V_{CE} = 600\text{ V}$					
$E_{on}$	$V_{CC} = 600\text{V}$	$T_j = 150^\circ\text{C}$		7.2		mJ
$E_{off}$	$I_C = 50\text{ A}$	$T_j = 150^\circ\text{C}$		5.6		mJ
$t_{d(on)}$	$R_{goff}/R_{goff} = 4.7\ \Omega$	$T_j = 150^\circ\text{C}$		1065		ns
$t_r$	$di/dt_{on} = 1061\text{ A}/\mu\text{s}$	$T_j = 150^\circ\text{C}$		50		ns
$t_{d(off)}$	$di/dt_{off} = 693\text{ A}/\mu\text{s}$	$T_j = 150^\circ\text{C}$		1670		ns
$t_f$		$T_j = 150^\circ\text{C}$		252		ns
$R_{th(j-s)}$	per IGBT			0.84		K/W
<b>Diode</b>						
$V_F = V_{EC}$	$I_F = 50\text{ A}$	$T_j = 25^\circ\text{C}$	2.25	2.55		V
	$V_{GE} = 0\text{ V (Chiplevel)}$	$T_j = 150^\circ\text{C}$	2.2	2.5		V
$V_{F0}$		$T_j = 25^\circ\text{C}$	1.3	1.5		V
		$T_j = 150^\circ\text{C}$	0.9	1.1		V
$r_F$		$T_j = 25^\circ\text{C}$	19	21		$\text{m}\Omega$
		$T_j = 150^\circ\text{C}$	26	28		$\text{m}\Omega$
$E_{rr}$	$I_F = 50\text{ A}$	$T_j = 150^\circ\text{C}$		3		mJ
$Q_{rr}$	$di_F/dt = -1479\text{ A}/\mu\text{s}$	$T_j = 150^\circ\text{C}$		8.3		$\mu\text{C}$
$I_{RRM}$	$V_{CC} = 600\text{ V}, V_{GE} = 0\text{ V}$	$T_j = 150^\circ\text{C}$		56		A
$R_{th(j-s)}$	per Diode			0.99		K/W

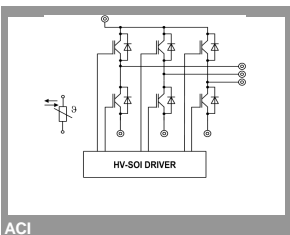

ACI

# SKiiP 25AC112T4V2

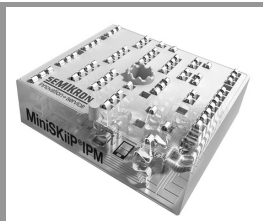

MiniSKiiP® AC IPM

Three-phase inverter intelligent power module

## SKiiP 25AC112T4V2

Data sheet status: preliminary

### Features

- One screw assembly of driver, module and heat sink
- Solder-free assembly of power, control and auxiliary contacts
- Trench-Field-Stop IGBT
- Robust and soft freewheeling diodes in CAL technology
- Latch-up free SOI driver IC
- Advanced level shifter technology
- Bootstrap power supply technology
- Matched propagation delay for all channels
- Overcurrent shut-down via current sensing
- Interlock logic for shoot-through prevention
- Common shut-down signal
- Undervoltage lockout for all channels with hysteresis band
- Integrated temperature sensor (NTC)
- RoHS compliant

### Typical Applications

- Industrial- & consumer drives
- Power supplies (SMPS & UPS)
- Industrial air conditioner

### Remarks

Electrical Characteristics (T <sub>s</sub> =25°C, unless otherwise specified)			Limits			
Symbol	Parameter	Conditions	min.	typ.	max.	Units
<b>Driver</b>						
VDC	Applied between VCC-VSS, VCCL-VSSL			15		V
ICC	VCC=15V, all logic inputs = open, VCC-VSS				5.0	mA
VBx	Applied between VB1-U, VB2-V, VB3-W			15		V
IBx	VBx = 15 V, V <sub>IH</sub> = V <sub>IL</sub> = 0 V			60		μA
V <sub>IT+</sub>	Applied between HIN1, HIN2, HIN3, LIN1, LIN2, LIN3, LIN4, /ERRIN-VSS			1.9	2.4	V
V <sub>IT-</sub>	Applied between HIN1, HIN2, HIN3, LIN1, LIN2, LIN3, LIN4, /ERRIN-VSS		0.8	1.1		V
V <sub>oErr</sub>	Error Output Voltage Applied between /ERROUT-VSS				15	V
V <sub>UV</sub>			10,5			V
V <sub>UVr</sub>					12,3	V
t <sub>d,ITRIP</sub>	Itrip to output propagation delay			500		ns
t <sub>SIS</sub>	Short pulse suppression for signals inputs			460		ns
t <sub>TD</sub>	Interlock Dead time			460		ns
f <sub>sw</sub>				15	25	kHz
<b>Temperature Sensor</b>						
R <sub>100</sub>	T <sub>Sensor</sub> = 100 °C (R <sub>25</sub> = 5 kΩ)			339		Ω
B <sub>100/125</sub>	R <sub>(T)</sub> = R <sub>100</sub> exp[B <sub>100/125</sub> (1/T-1/373)]; [T] = K			4096		K
<b>Module</b>						
m					65	g
M <sub>S</sub>			2		2.5	Nm

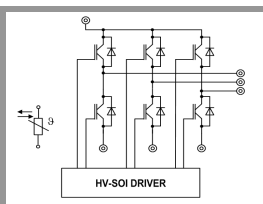

ACI

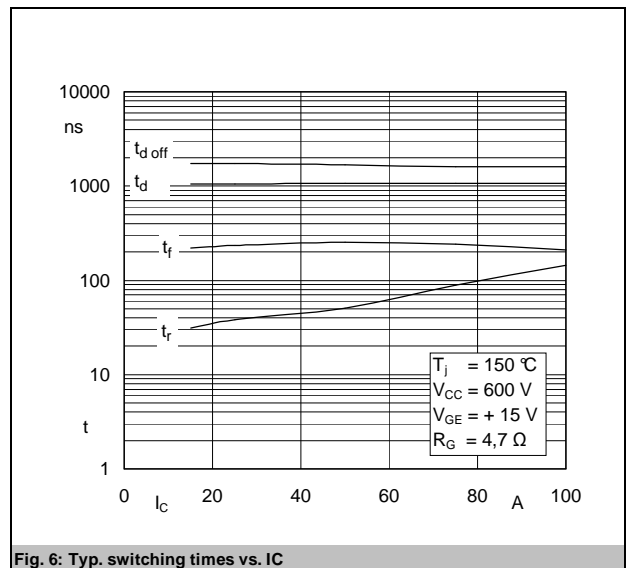
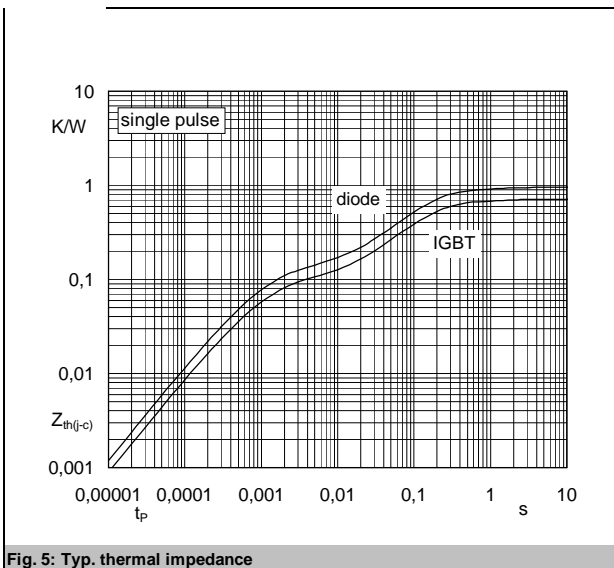
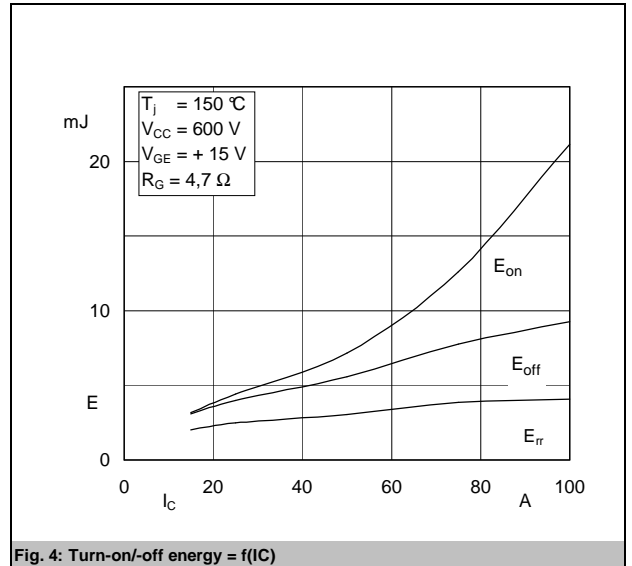
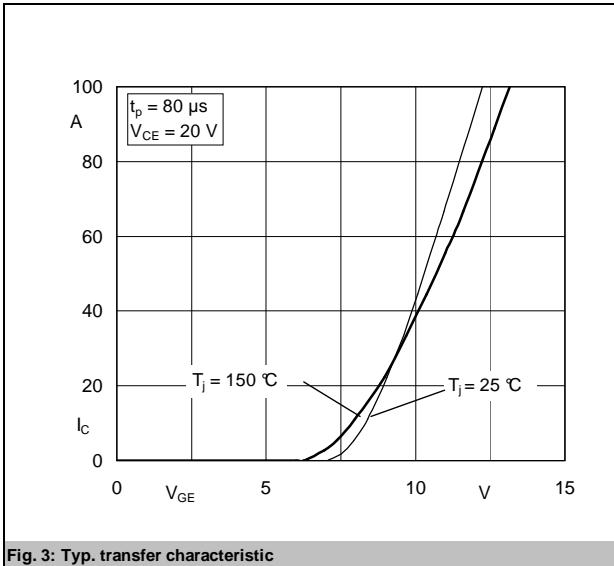
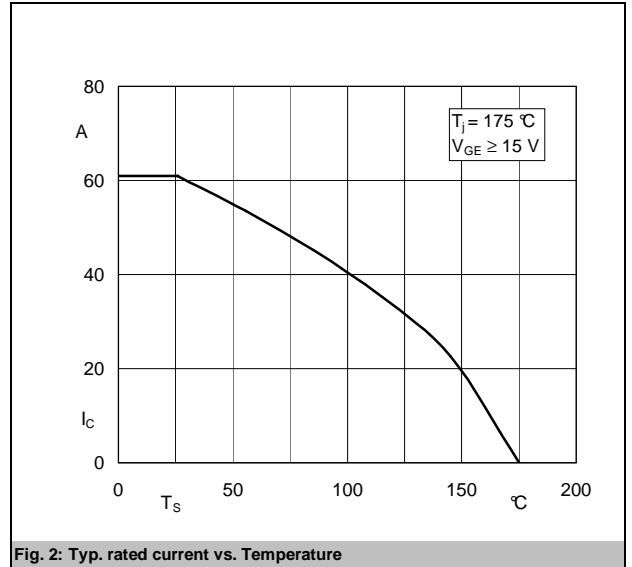
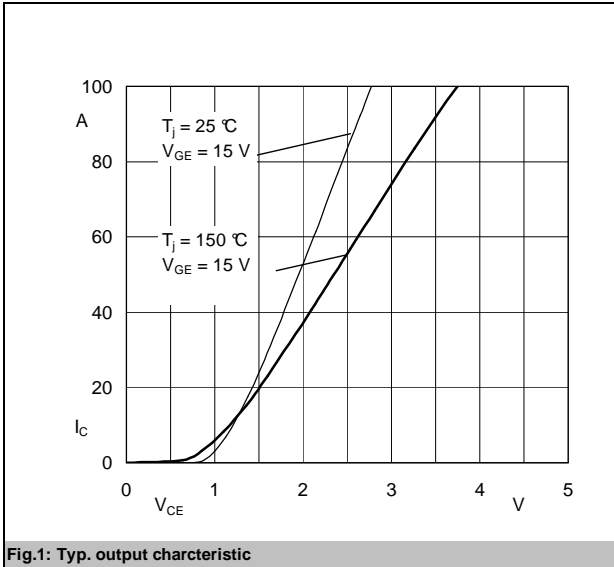

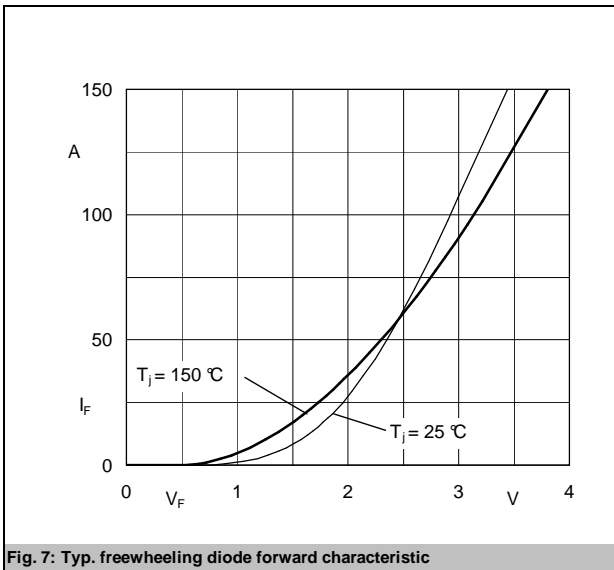

Fig. 7: Typ. freewheeling diode forward characteristic

Pin Number	Signal Name	Description
1	VB1	Floating supply for U phase high side IGBT
2	HIN1	PWM signal input for U phase high side switch
3	LIN1	PWM signal input for U phase low side switch
4	HIN2	PWM signal input for V phase high side switch
5	VCC	Driver IC main supply voltage
6	HIN3	PWM signal input for W phase high side switch
7	/ERRIN	External error / shut-down logic input (inverted)
8	VSS	Driver IC supply voltage ground
9	/ERROUT	Error logic output (inverted)
10	ITRIP	Comparator input / current sense input for overcurrent shut-down
11	VSSL	Low side supply voltage ground
12	VCCL	Low side supply voltage
13	VB2	Floating supply for V phase high side IGBT
14	VB3	Floating supply for W phase high side IGBT
15	LIN2	PWM signal input for V phase low side switch
16	LIN3	PWM signal input for W phase low side switch
	U	U phase power output
	E1	Auxiliary emitter terminal for U phase high side IGBT
	V	V phase power output
	E3	Auxiliary emitter terminal for V phase high side IGBT
	W	W phase power output
	E5	Auxiliary emitter terminal for W phase high side IGBT
	NU	Negative DC-Link power terminal for U phase
	E2	Auxiliary emitter terminal for U phase low side IGBT
	NV	Negative DC-Link power terminal for V phase
	E4	Auxiliary emitter terminal for V phase low side IGBT
	NW	Negative DC-Link power terminal for W phase
	E6	Auxiliary emitter terminal for W phase low side IGBT
	P	Positive DC-Link power terminal
	+T	Temperature sensor terminal (+)
	-T	Temperature sensor terminal (-)

Fig. 4: PIN Description

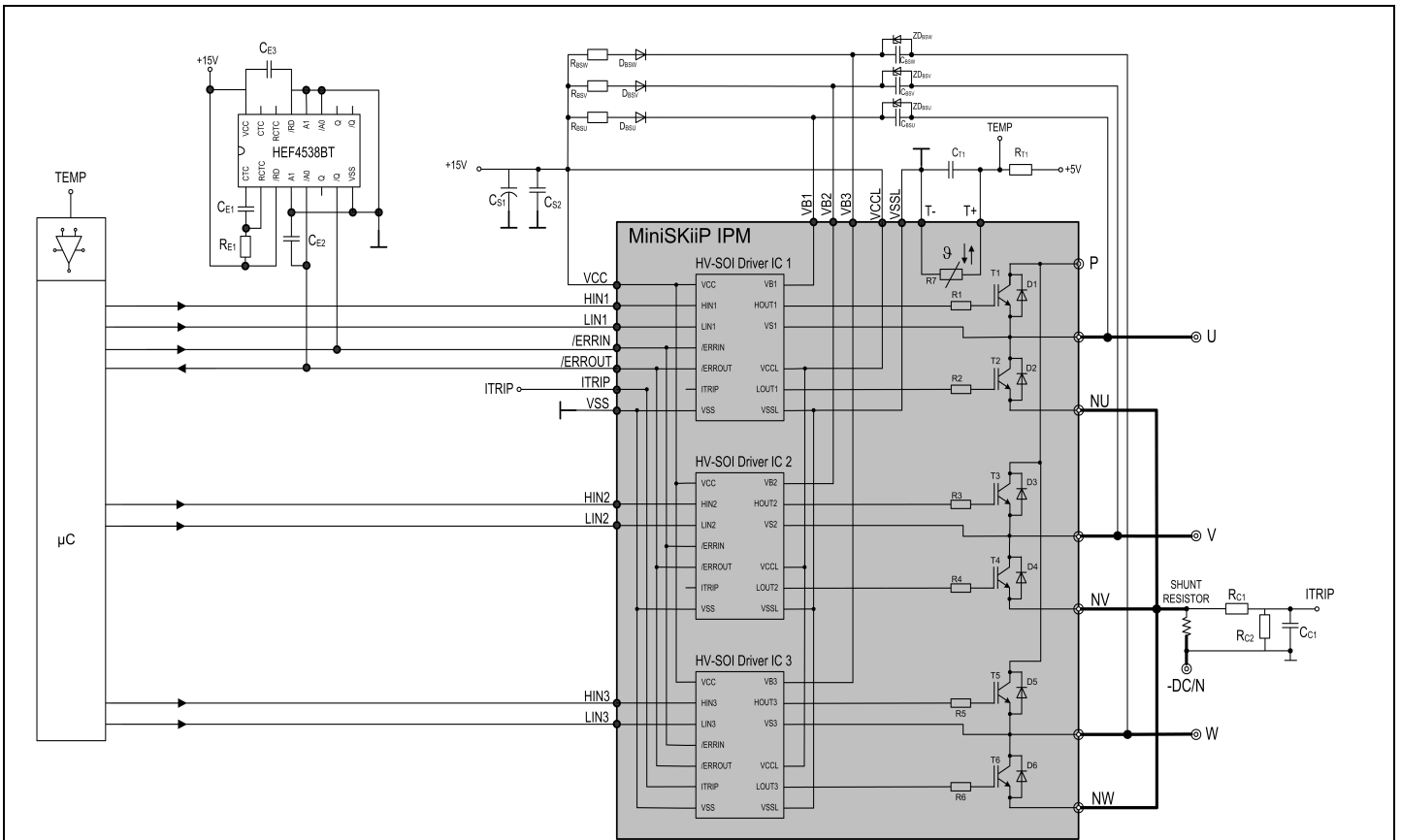

Fig. 5: Internal Circuit and Typ. Application

