

BV 8, BV 12, BV 16

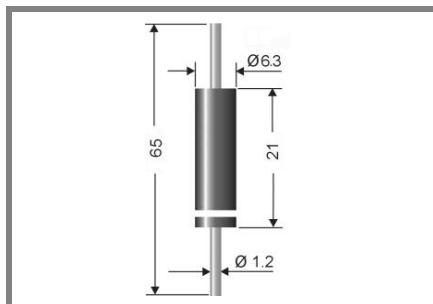

Axial lead diode

High voltage silicon rectifier diodes

BV 8, BV 12, BV 16

Forward Current: 0,5 A

Reverse Voltage: 8000 to 16000 V

Features

- Max. solder temperature: 260°C
- Plastic material has UL classification 94V-0

Mechanical Data

- Plastic case 6,3 x 21 [mm]
- Weight approx.: 1,9 g
- Terminals: plated terminals solderable per MIL-STD-750
- Mounting position: any
- Standard packaging: 100 pieces per ammo

1) Valid, if leads are kept at ambient temperature at a distance of 10 mm from case

2) $I_{FAV} = 500 \text{ mA}$, $T_j = 25 \text{ °C}$

3) $T_A = 25 \text{ °C}$

4) $I_{FAV} = 300 \text{ mA}$, $T_j = 25 \text{ °C}$

Type	Repetitive peak reverse voltage	Surge peak reverse voltage	Max. reverse recovery time	Max. forward voltage
	V_{RRM} V	V_{RSM} V	$I_F = -A$ $I_R = -A$ $I_{RR} = -A$ t_{rr} ns	$V_F^{2)}$
BV 8	8000	8000	-	8
BV 12	12000	12000	-	8
BV 16	16000	16000	-	15 ⁴⁾

Absolute Maximum Ratings		$T_c = 25 \text{ °C}$, unless otherwise specified	
Symbol	Conditions	Values	Units
I_{FAV}	Max. averaged fwd. current, R-load, $T_A = 50 \text{ °C}$ ¹⁾	0,5	A
I_{FRM}	Repetitive peak forward current $f > \text{Hz}$ ¹⁾		A
I_{FSM}	Peak forward surge current 50 Hz half sinus-wave ³⁾	100	A
i^2t	Rating for fusing, $t < \text{ms}$ ³⁾		A ² s
R_{thA}	Max. thermal resistance junction to ambient ¹⁾	25	K/W
R_{thT}	Max. thermal resistance junction to terminals ¹⁾		K/W
T_j	Operating junction temperature	-50...+150	°C
T_s	Storage temperature	-50...+150	°C

Characteristics		$T_c = 25 \text{ °C}$, unless otherwise specified	
Symbol	Conditions	Values	Units
I_R	Maximum leakage current, $T_j = 25 \text{ °C}$; $V_R = V_{RRM}$	<1	µA
	$T_j = 100 \text{ °C}$; $V_R = V_{RRM}$	<25	µA
C_j	Typical junction capacitance (at MHz and applied reverse voltage of V)	-	pF
Q_{rr}	Reverse recovery charge ($U_R = V$; $I_F = A$; $dI_F/dt = A/\text{ms}$)	-	µC
E_{RSM}	Non repetitive peak reverse avalanche energy ($I_R = \text{mA}$; $T_j = \text{°C}$; inductive load switched off)	-	mJ

