

Product Manual

Vandal-proof latching action switch MSM LA

**CONTENTS**

**1 PRODUCT DESCRIPTION ..... 2**

**2 TECHNICAL DATA AND DIMENSIONAL DRAWINGS ..... 2**

2.1 Technical Data .....2

2.2 Dimensional Drawings .....5

2.3 Hole Dimensions .....7

2.4 Starting Torque.....7

2.5 Switching Symbols.....8

2.6 Contact Layout .....9

**3 ORDER NUMBERS ..... 10**

3.1 Order Numbers MSM LA .....10

3.2 Lettering.....11

**4 ASSEMBLY ..... 13**

4.1 Installation .....13

**5 PACKAGING ..... 14**

**6 QUALIFICATION TEST ..... 15**

6.1 IP Protection Class .....15

6.2 IK Protection Class .....15

6.3 ESD Protection.....15

6.4 Salt Spray Test.....15

**7 APPROVALS ..... 16**

**8 COMPLIANTS..... 16**

Changes that contribute to technical improvement are subject to alternations							
page	issue date:	created by:	amendment date:	released by:	amendment no.:	datasheet no.:	index
1 of 16	04.08.2007	Mangold	07.12.2010	Schillak	10321	105.9526.200	h

## 1 PRODUCT DESCRIPTION

- housing and actuator are made of high-quality stainless steel
- switch is particularly suitable for use in equipment in harsh environments or for vandal-protected applications
- available with mounting diameters of 19 and 22 mm
- suitable for use in temperatures ranging from -20 °C to +85 °C
- permissible switching voltages up to 125 VDC / 250 VAC
- switching status (ON/OFF) is easy to discern by looking at, or feeling, the resting position of the actuator; in the off state, the actuator position protrudes from the housing; in the ON state, it is depressed into the housing
- with quick connect terminals to allow for fast connections
- point and ring illuminated versions in red, green and blue are available for indicating the switching status or for providing visibility during night-time use
- available in single-pole and double-pole versions

## 2 TECHNICAL DATA AND DIMENSIONAL DRAWINGS

### 2.1 Technical Data

<b>Electrical Data</b>		
Switching Voltage max.	[V <sub>DC</sub> ]	30 (125VDC/0,5A) <sup>1)</sup>
Switching Voltage max.	[V <sub>AC</sub> ]	250
Switching Current max.	[A <sub>AC</sub> ]	12
Rated Braking Capacity	[W <sub>AC</sub> ]	3000
Lifetime (at 8A / 250 VAC)	[Actuations]	50.000
Lifetime <sup>1)</sup> (at 0,5A / 125 VDC)	[Actuations]	100.000
Initial Contact Resistance (at 12V / 1 ADC)	[mΩ]	< 100
Insulation Resistance (500 VDC)	[MΩ]	> 100

1) Direct current Lifetime testing accomplished for switch element 1682.1101 with an actuation frequency of 1 Hz and an actuation velocity of 100 mm/s.

<b>Ring Illumination (RI)</b>	MSM 19 LA RI and MSM 22 LA RI
Supply Voltage $U_{LED}$ [V <sub>DC</sub> ]	24

<b>Point Illumination (PI)</b>	<b>Attention: Parts are delivered without series resistor.</b>
Characteristics <b>LED red</b> Point Illumination	Forward Current max. 40 mA Forward Voltage at 10 mA = 2.0 VDC Forward Voltage max. = 2.5 VDC
Characteristics <b>LED green</b> Point Illumination	Forward Current max. 40 mA Forward Voltage at 10 mA = 2.0 VDC Forward Voltage max. = 2.5 VDC
Characteristics <b>LED blue</b> Point Illumination	Forward Current max. 20 mA Forward Voltage at 10 mA = 3.2 VDC Forward Voltage max. = 3.7 VDC

**Recommendation of series resistors for Point Illumination:**

LED-Color	$I_D$ [mA]	$I_{DMax}$ [mA]	$U_V$ [V]				$U_V$ [V]				$U_V$ [V]			
			5	$R_V$ [Ω]	$R_V^{E24}$ [Ω]	$P_V$ [W]**	12	$R_V$ [Ω]	$R_V^{E24}$ [Ω]	$P_V$ [W]**	24	$R_V$ [Ω]	$R_V^{E24}$ [Ω]	$P_V$ [W]
red	10	---		300	300	0,03		1000	1000	0,10		2200	2200	0,22
	---	40		63	62	0,10		238	240	0,38		538	240	0,86
green	10	---		300	300	0,03		1000	1000	0,10		2200	2200	0,22
	---	40		63	62	0,10		238	240	0,38		538	560	0,86
blue	10	---		180	180	0,02		880	910	0,09		2080	2000	0,21
	---	20		65	68	0,03		415	430	0,17		1015	1000	0,41

- $I_D$  LED-Forward Current [10mA]
- $I_{DMax}$  LED-Forward Current max. [40mA/20mA]
- $R_V$  Series Resistor (calculated)
- $R_V^{E24}$  Series Resistor (regarding E24-Resistor series)
- $P_V$  Power dissipation concerning  $R_V$  (calculated)

Changes that contribute to technical improvement are subject to alternations							
page	issue date:	created by:	amendment date:	released by:	amendment no.:	datasheet no.:	index
3 of 16	04.08.2007	Mangold	07.12.2010	Schillak	10321	105.9526.200	h

<b>Mechanical Data</b>		
Actuating Force typ.	[N]	10
Actuating Travel typ.	[mm]	5.2
Lifetime mechanical	[Actuations]	100.000
Contact Gap	[mm]	3
Shock Resistance (DIN EN 50102)	[IK]	07

<b>Starting Torque</b>		MSM 19 LA	MSM 22 LA
Plastic Nut max.	[Nm]	4.5	3.5
Stainless Steel Nut* max.	[Nm]	12	16

\* on request

<b>Climatic Data</b>		
Operating Temperature	[°C]	-20 to +85
Storage Temperature	[°C]	-20 to +85
Degree of Protection (DIN EN 60529)	[IP]	IP 64 Front Side IP 00 Rear Side

<b>Material</b>	
<b>Component</b>	<b>Material with flammability rating</b>
Push button holder	PA66 (UL94-V0 related to d ≥ 1.6 mm)
Intermediate Connector	PA66 (UL94-V0 related to d ≥ 1.6 mm)
Contact Pin Adapter	PA66 (UL94-V0 related to d ≥ 1.6 mm)
<b>Component</b>	<b>Material without flammability rating</b>
Housing	Stainless Steel 1.4305
Actuator (disc, outside housing)	Stainless Steel 1.4305
Illuminated Ring (die-casting, inside housing)	PC
Sealing Ring	NBR70



## 2.2.2 Component Dimensions M22

### MSM 22 LA ST double-pole / MSM 22 LA LE double-pole

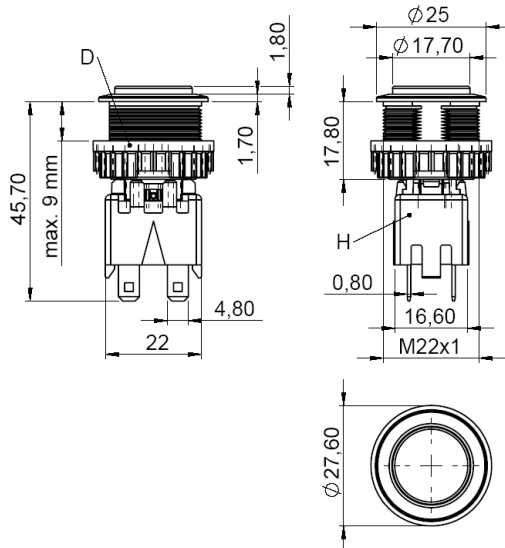

### MSM 22 LA PI double-pole

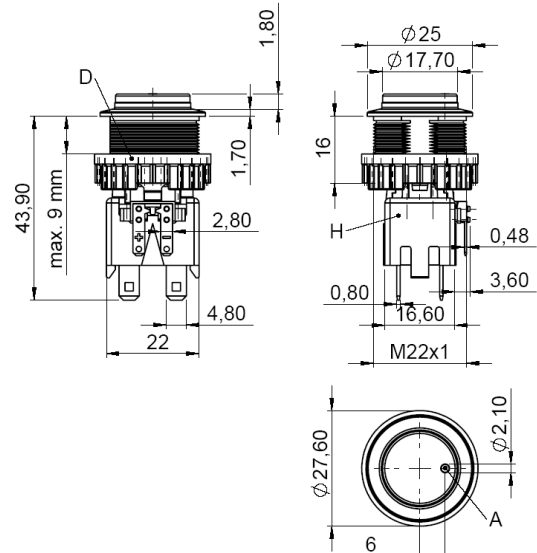

### MSM 22 LA RI double-pole

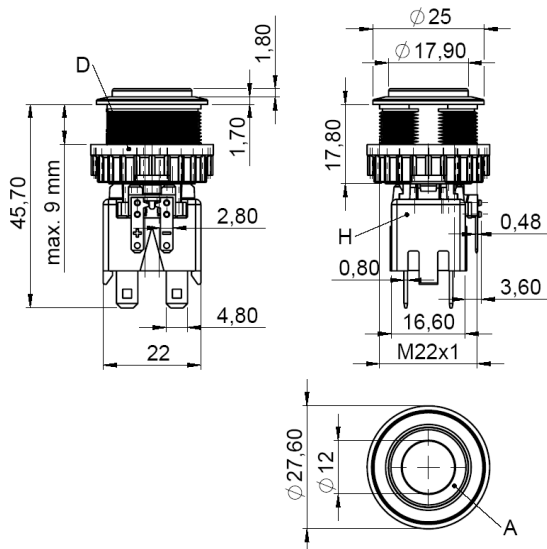

### Switching Element single-pole

consists of: switch single-pole + push button holder

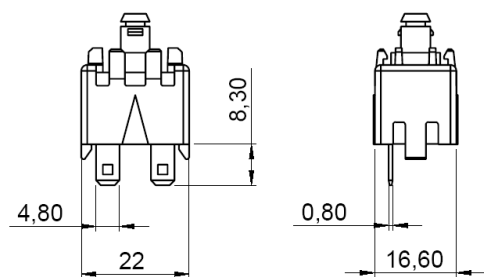

### Legend

- A = Illumination Area
- D = Knurled Nut
- H = Switching Element

Changes that contribute to technical improvement are subject to alternations							
page	issue date:	created by:	amendment date:	released by:	amendment no.:	datasheet no.:	index
6 of 16	04.08.2007	Mangold	07.12.2010	Schillak	10321	105.9526.200	h

### 2.3 Hole Dimensions

**MSM 19 LA (without torsion protection)**

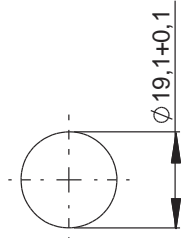

**MSM 19 LA (with torsion protection)**

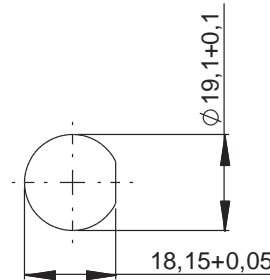

**MSM 22 LA (without torsion protection)**

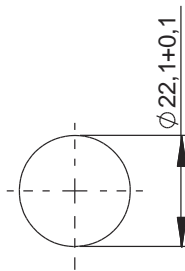

**MSM 22 LA (with torsion protection)\***

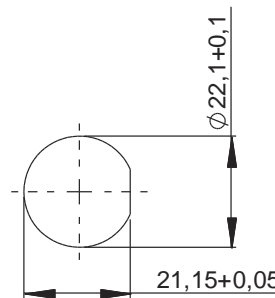

\* **Hole Dimensions with torsion protection:**

- recommended for version „Ring Illumination“
- required for version „Point Illumination“ and „Lettered“

### 2.4 Starting Torque

	Plastic Nut max. (Nm)	Stainless Steel Nut * max. (Nm)
MSM 19	4.5	12
MSM 22	3.5	16

➤ \* on request

## 2.5 Switching Symbols

**MSM LA ST single-pole /  
MSM LA LE single-pole**

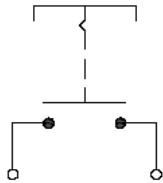

**MSM LA ST double-pole /  
MSM LA LE double-pole**

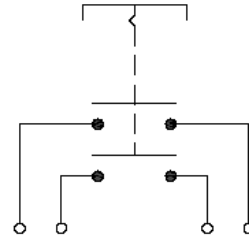

**MSM LA PI single-pole**

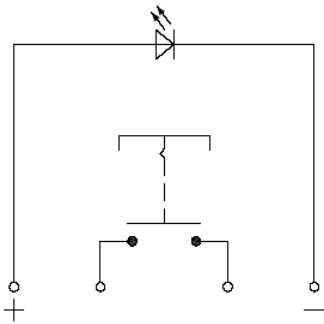

**MSM LA PI double-pole**

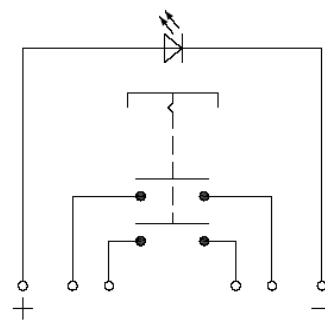

**MSM LA RI single-pole**

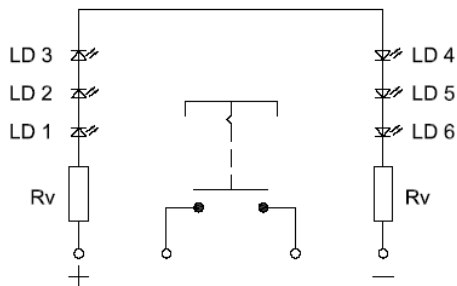

**MSM LA RI double-pole**

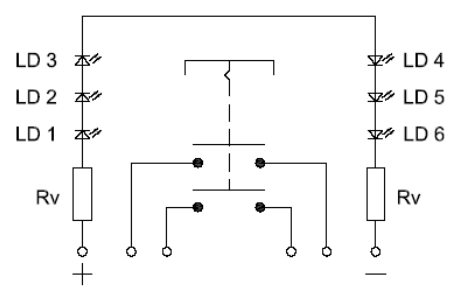

Changes that contribute to technical improvement are subject to alternations

page	issue date:	created by:	amendment date:	released by:	amendment no.:	datasheet no.:	index
8 of 16	04.08.2007	Mangold	07.12.2010	Schillak	10321	105.9526.200	h

## 2.6 Contact Layout

Contact Layout single-pole

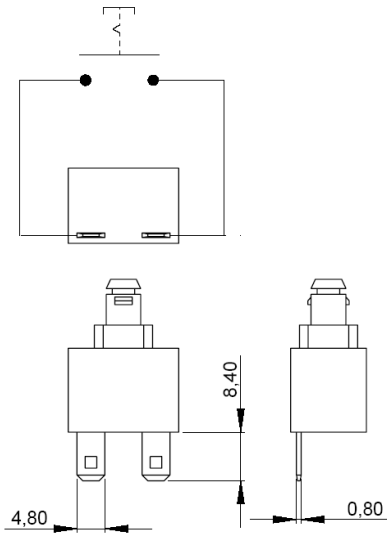

Contact Layout double-pole

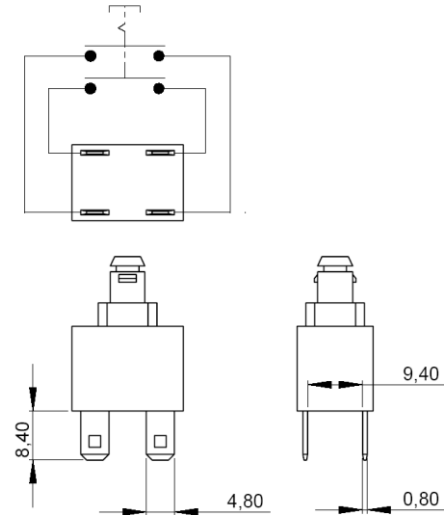

Changes that contribute to technical improvement are subject to alternations							
page	issue date:	created by:	amendment date:	released by:	amendment no.:	datasheet no.:	index
9 of 16	04.08.2007	Mangold	07.12.2010	Schillak	10321	105.9526.200	h

### 3 ORDER NUMBERS

#### 3.1 Order Numbers MSM LA

Mounting Diameter (mm)	Ø 19	Ø 22
<b>Latching Action Switch, single-pole</b>		
<b>ST</b> (Standard)	1241.6821.1110000	1241.6831.1110000
<b>LE</b> (Lettering) *	1241.6822.1110XXX	1241.6832.1110XXX
<b>PI</b> (Point Illumination) <b>red</b>	1241.6823.1111000	1241.6833.1111000
<b>PI</b> (Point Illumination) <b>green</b>	1241.6823.1112000	1241.6833.1112000
<b>PI</b> (Point Illumination) <b>blue</b>	1241.6823.1114000	1241.6833.1114000
<b>RI</b> (Ring Illumination) <b>red</b>	1241.6824.1111000	1241.6834.1111000
<b>RI</b> (Ring Illumination) <b>green</b>	1241.6824.1112000	1241.6834.1112000
<b>RI</b> (Ring Illumination) <b>blue</b>	1241.6824.1114000	1241.6834.1114000
<b>Latching Action Switch, double-pole</b>		
<b>ST</b> (Standard)	1241.6821.1120000	1241.6831.1120000
<b>LE</b> (Lettering) *	1241.6822.1120XXX	1241.6832.1120XXX
<b>PI</b> (Point Illumination) <b>red</b>	1241.6823.1121000	1241.6833.1121000
<b>PI</b> (Point Illumination) <b>green</b>	1241.6823.1122000	1241.6833.1122000
<b>PI</b> (Point Illumination) <b>blue</b>	1241.6823.1124000	1241.6833.1124000
<b>RI</b> (Ring Illumination) <b>red</b>	1241.6824.1121000	1241.6834.1121000
<b>RI</b> (Ring Illumination) <b>green</b>	1241.6824.1122000	1241.6834.1122000
<b>RI</b> (Ring Illumination) <b>blue</b>	1241.6824.1124000	1241.6834.1124000

\* Lettering Index see under [chapter 3.2](#)





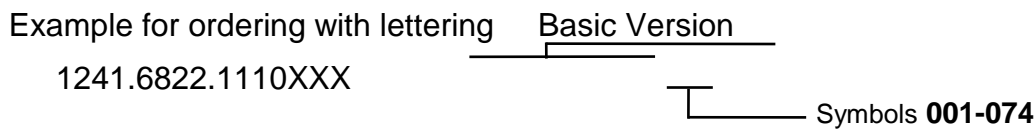

### 3.2 Lettering

The last three digits in the order number define the lettering.

000	No Lettering
001-074	Standard Lettering
101-	Customized Lettering



#### Ordering Indices for Lettering

001= <b>A</b>	016= <b>P</b>	031= <b>4</b>	046= 	061= <b>EIN</b>
002= <b>B</b>	017= <b>Q</b>	032= <b>5</b>	047= 	062= <b>AUS</b>
003= <b>C</b>	018= <b>R</b>	033= <b>6</b>	048= 	063= <b>AUF</b>
004= <b>D</b>	019= <b>S</b>	034= <b>7</b>	049= 	064= <b>AB</b>
005= <b>E</b>	020= <b>T</b>	035= <b>8</b>	050= 	065= <b>ON</b>
006= <b>F</b>	021= <b>U</b>	036= <b>9</b>	051= <b>%</b>	066= <b>OFF</b>
007= <b>G</b>	022= <b>V</b>	037= <b>+</b>	052= 	067= <b>UP</b>
008= <b>H</b>	023= <b>W</b>	038= <b>-</b>	053= <b>CTRL</b>	068= <b>DOWN</b>
009= <b>I</b>	024= <b>X</b>	039= <b>.</b>	054= <b>RETURN</b>	069= <b>HIGH</b>
010= <b>J</b>	025= <b>Y</b>	040= <b>x</b>	055= <b>SHIFT</b>	070= <b>LOW</b>
011= <b>K</b>	026= <b>Z</b>	041= <b>÷</b>	056= <b>LOCK</b>	071= <b>ON/OFF</b>
012= <b>L</b>	027= <b>0</b>	042= <b>*</b>	057= <b>STOP</b>	072= <b>START</b>
013= <b>M</b>	028= <b>1</b>	043= <b>=</b>	058= <b>ENTER</b>	073= <b>RESET</b>
014= <b>N</b>	029= <b>2</b>	044= <b>#</b>	059= <b>BACK</b>	074= 
015= <b>O</b>	030= <b>3</b>	045= <b>↔</b>	060= <b>LINE</b>	

Changes that contribute to technical improvement are subject to alternations							
page	issue date:	created by:	amendment date:	released by:	amendment no.:	datasheet no.:	index
11 of 16	04.08.2007	Mangold	07.12.2010	Schillak	10321	105.9526.200	h

## Font Size

### **MSM 19 LA LE / MSM 19 LA PI :**

<b>Single characters:</b>	height 8 mm, font: Helvetica normal DIN1451-1E
<b>Text, max. 3 characters</b>	height 3 mm, font: Helvetica normal DIN1451-1E
<b>Text, max. 6 characters:</b>	height 2.5 mm, font: Helvetica condensed DIN1451-3E
<b>Symbols (indices 037-052):</b>	capitals height 8 mm, font: True Type, Symbol

### **MSM 22 LA LE / MSM 22 LA PI :**

<b>Single characters:</b>	height 8 mm, font: Helvetica normal DIN1451-1E
<b>Text, max. 3 characters</b>	height 5 mm, font: Helvetica normal DIN1451-1E
<b>Text, max. 6 characters:</b>	height 2.5 mm, font: Helvetica condensed DIN1451-3E
<b>Symbols (indices 037-052):</b>	capitals height 8 mm, font: True Type, Symbol

### **MSM 19 LA RI \* / MSM 22 LA RI**

**\***

<b>Single characters:</b>	height 5 mm, font: Helvetica normal DIN1451-1E
<b>Text, max. 3 characters</b>	height 3 mm, font: Helvetica normal DIN1451-1E
<b>Symbols (indices 037-052):</b>	capitals height 5 mm, font: True Type, Symbol

- *\* At a minimum order quantity of 100 pieces the ring illuminated version with lettering is available on request.*

Changes that contribute to technical improvement are subject to alternations							
page	issue date:	created by:	amendment date:	released by:	amendment no.:	datasheet no.:	index
12 of 16	04.08.2007	Mangold	07.12.2010	Schillak	10321	105.9526.200	h

## 4 ASSEMBLY

### 4.1 Installation

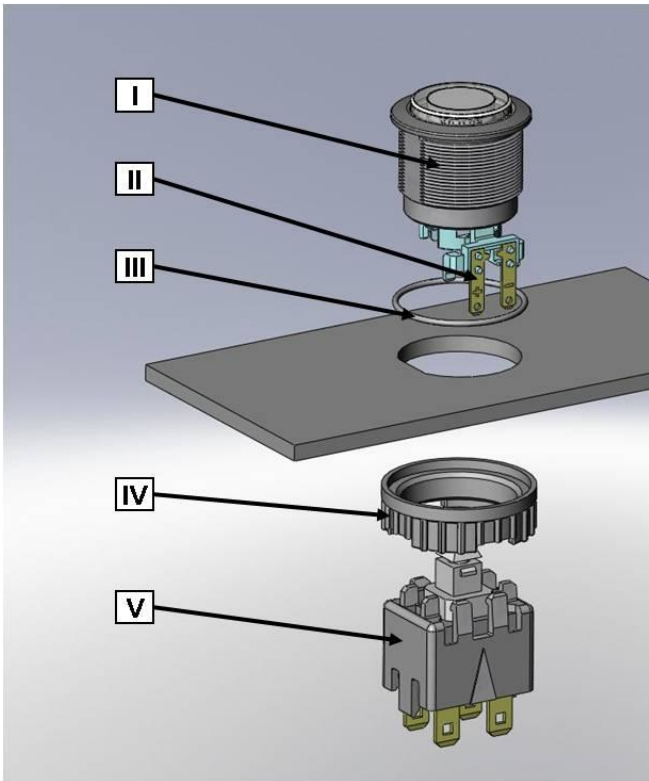

#### Installation instruction

1. Place the gasket accurately on the actuator housing. Then mount the actuator housing assembly into the panel.
2. Tighten the screw nut with the torque instructions according to [Chapter 2.4](#)
3. Clasp the push button switch assembly into the actuator housing.

#### Installation information:

1. The power supply and the configuration of the flat pin terminals has to be installed correctly for the illumination and push button switch function.
2. Insulate the terminals as required
3. Installation instructions according to VDE-standard DIN VDE 0100-100 or alternatively IEC 60354 standard

#### Legend

- I = Housing Assembly
- II = Flat Pin Terminals (illumination)
- III = Gasket
- IV = Screw Nut
- V = Push Button Switch Assembly

Changes that contribute to technical improvement are subject to alternations

page	issue date:	created by:	amendment date:	released by:	amendment no.:	datasheet no.:	index
13 of 16	04.08.2007	Mangold	07.12.2010	Schillak	10321	105.9526.200	h

Print date: 10/12/2010 14:40:00

## 5 PACKAGING

### MSM LA

MSM 19 LA	10 pieces per box with inlay
MSM 22 LA	10 pieces per box with inlay

The screw nuts with sealing rings and corresponding switching elements are packed separately and enclosed in the box.



Changes that contribute to technical improvement are subject to alternations							
page	issue date:	created by:	amendment date:	released by:	amendment no.:	datasheet no.:	index
14 of 16	04.08.2007	Mangold	07.12.2010	Schillak	10321	105.9526.200	h

## 6 QUALIFICATION TEST

### 6.1 IP Protection Class

IP Protection Class IEC/DIN/EN/60529	IP 64 Front Side IP 00 Rear Side
--------------------------------------	-------------------------------------

### 6.2 IK Protection Class

Tested centrally

IK Protection Class DIN EN 50102	IK 07
----------------------------------	-------

### 6.3 ESD Protection

ESD test according to DIN 61000-4-2:

4kV Contact Discharge	MSM LA ST MSM LA LE	Ø 19; 22 mm
-----------------------	------------------------	-------------

### 6.4 Salt Spray Test

Salt spray test according to DIN 50021- SS  
24h, 48h and 96h residence time

The surface of the stainless steel material is covered with a molecular-passive layer. Only under very unfavourable conditions it is possible, that iron and rust molecules as well as base metals penetrate the passive layer as foreign substances (pollutions) and initiate the rust process.

The smoothness of the actuator was not affected. After the residence time the tested samples were cleaned under running water and all rust spots could be removed.

Changes that contribute to technical improvement are subject to alternations							
page	issue date:	created by:	amendment date:	released by:	amendment no.:	datasheet no.:	index
15 of 16	04.08.2007	Mangold	07.12.2010	Schillak	10321	105.9526.200	h

## 7 APPROVALS

The listed approvals only refer to the push button switch and not to the complete switch.

### Push button switch:

Type	Identification Number	ENEC VDE / KEMA	UL 1054 CSA C22.2 NO55
1681.1101	KEMA 2106068.01	DIN EN 61058	E41791
1682.1101	KEMA 2106068.01	DIN EN 61058	E41791

## 8 COMPLIANTS

All articles are ROHS-compliant and in compliance to the Low Voltage Directive (2006/95/EC).



Changes that contribute to technical improvement are subject to alternations							
page	issue date:	created by:	amendment date:	released by:	amendment no.:	datasheet no.:	index
16 of 16	04.08.2007	Mangold	07.12.2010	Schillak	10321	105.9526.200	h