



SAMXON BRAND ALUMINUM ELECTROLYTIC CAPACITORS

PRODUCT SPECIFICATION

規格書

CUSTOMER : TRANSFER (客戶):	DATE : 2015-03-07 (日期):
-------------------------------------	-----------------------------------

CATEGORY (品名)	: ALUMINUM ELECTROLYTIC CAPACITORS
DESCRIPTION (型号)	: WL 450V1500 μ F(ϕ 51x115)
VERSION (版本)	: 01
Customer P/N	:
SUPPLIER	:

SUPPLIER	
PREPARED (拟定)	CHECKED (审核)
叶青	吴仁奎

CUSTOMER	
APPROVAL (批准)	SIGNATURE (签名)

Table 1 Product Dimensions and Characteristics

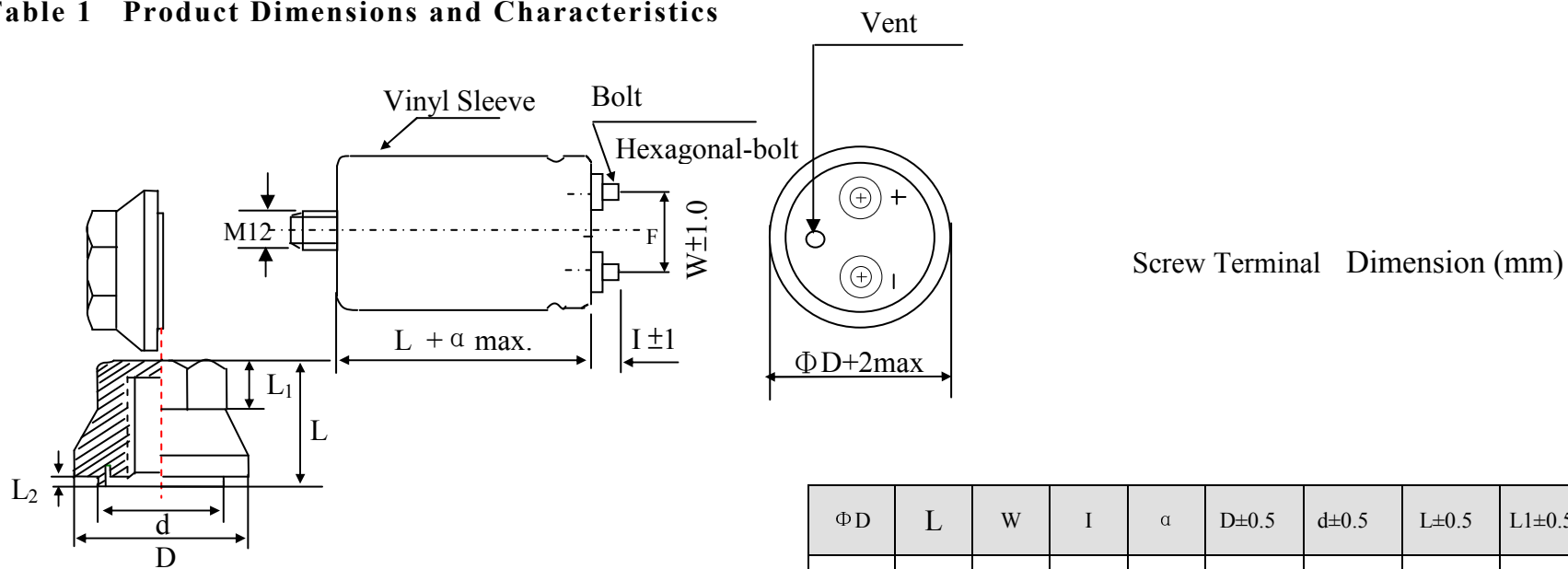

ΦD	L	W	I	α	$D \pm 0.5$	$d \pm 0.5$	$L \pm 0.5$	$L_1 \pm 0.5$	$L_2 \pm 0.2$
51	115	22.0	6.0	3	38.0	30.0	18.0	7.0	1.45

No.	SAMXON Part No.	WV (Vdc)	Cap. (μF)	Cap. tolerance	Temp. range($^{\circ}\text{C}$)	$\tan \delta$ (120Hz, 20°C)	Leakage Current (μA , 5min)	Max Ripple Current at 85°C 120Hz (A rms)	Load lifetime (Hrs)	Sleeve
1	EWL158M2WS1AO5**W	450	1500	-20%~+20%	-25~85	0.25	5000	6.53	20000	PVC

Issued-date: 2015-03-07

Specification Sheet -WL

Version

01

Page 2

STANDARD MANUAL

CONTENTS

	Sheet
1. Application	4
2. Part Number System	4
3. Construction	5
4. Characteristics	6~13
4.1 Rated voltage & Surge voltage	
4.2 Capacitance (Tolerance)	
4.3 Leakage current	
4.4 $\tan \delta$	
4.5 Terminal strength	
4.6 Temperature characteristic	
4.7 Load life test	
4.8 Shelf life test	
4.9 Surge test	
4.10 Vibration	
4.11 Solderability test	
4.12 Resistance to solder heat	
4.13 Change of temperature	
4.14 Damp heat test	
4.15 Vent test	
4.16 Maximum permissible (ripple current)	
5. List of “Environment-related Substances to be Controlled (‘Controlled Substances’)”	13
Attachment: Application Guidelines	14~19

1. Application

This specification applies to polar Aluminum electrolytic capacitor (foil type) used in electronic equipment. Designed capacitor's quality meets IEC60384.

2. Part Number System



Series	Cap(MFD)	Code	Tolerance (%)	Code	Voltage (W.V.)	Code	Case Size	Feature	Code	SAMXON Product Line		
ESM	0.1	104	±5	J	2	0D	3	Radial bulk	RR	For internal use only (The product lines we have H,A,B,C,D, E,M or 0,1,2,3,4,5,9).		
EKF					2.5	0E		4	0G		Ammo Taping	
ESS					4	0G		5	0J		2.0mm Pitch	TT
EKS	0.22	224	±10	K	6.3	0J	6					
EGS					8	0K	7		2.5mm Pitch		TU	
EKM					10	1A	8					
EKG	0.33	334	±15	L	12.5	1B	9					
EOM					16	1C	10		3.5mm Pitch		TV	
EZM					20	1D	11					
EZS	0.47	474	±20	M	25	1E	12					
EGF					30	1I	13		5.0mm Pitch	TC		
ESF					32	13	14					
EGT	1	105	±30	N	35	1V	15					
EGK					40	1G	16		Lead Cut & Form			
EGE					42	1M	17					
EGD	2.2	225	-40	W	50	1H	18					
EGC					57	1L	19		CB-Type	CB		
ERS					63	1J	20					
ERF	3.3	335	-20	A	71	1S	21					
ERL					75	1T	22		CE-Type	CE		
ERR					80	1K	23					
ERT	4.7	475	+10	C	85	1R	24					
ERE					90	19	25		HE-Type	HE		
ERD					90	19	26					
ERH	10	106	-20	X	100	2A	27					
EBD					100	2A	28		KD-Type	KD		
ERA					120	2O	29					
ERB	22	226	+40	S	125	2B	30					
ERC					150	2Z	31		FD-Type	FD		
EFA					160	2C	32					
ENP	47	476	-20	B	150	2Z	33					
ENH					160	2C	34		EH-Type	EH		
ERW					180	2P	35					
ERY	100	107	+30	Q	200	2D	36					
ELP					215	22	37		PCB Terminal			
EAP					220	22	38					
EKP	330	337	-10	V	220	2N	39					
EPP					230	23	40		Snap-in	SW		
ESP					250	2E	41			SX		
EVP	470	477	+50	T	275	2T	42					
EGP					280	2E	43			SZ		
EWR					290	2J	44		Lug	SG		
EWU	2200	228	-5	E	300	2I	45					
EWF					310	2R	46			O5		
EWS					315	2F	47			O6		
EWH	47000	479	+20	G	330	2U	48					
EWL					350	2V	49			T5		
EWB					360	2X	50			T6		
VSS	150000	15T	0	O	375	2Q	51					
VNS					385	2Y	52			D5		
VKS					400	2G	53			D6		
VKM	220000	22T	+5	I	420	2M	54					
VRL					450	2W	55					
VNH					500	2H	56					
VZS	330000	33T	+15	Z	550	25	57					
VRF					600	26	58					
					630	2J	59					

For internal use only
(The product lines we have H,A,B,C,D, E,M or 0,1,2,3,4,5,9).

Sleeve Material	Code
PET	P
PVC	

If the sleeve material is PVC, there will be blank in seventeenth digit.

3. Construction

Single ended type to be produced to fix the terminals to anode and cathode foil, and wind together with paper, and then wound element to be impregnated with electrolyte will be enclosed in an aluminum case. Finally sealed up tightly with end seal rubber, then finished by putting on the vinyl sleeve.

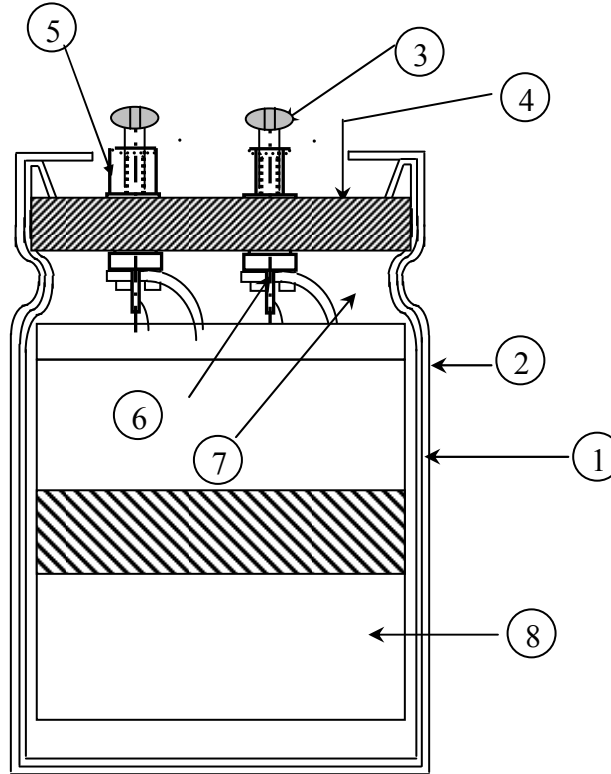

No	Component	Material
1	Case	Aluminum case
2	Sleeve	PVC
3	Screw	Iron
4	Seal	PPS
5	Nut	Bakelite
6	Washer	Aluminum
7	Tab	Aluminum
8	Element	Aluminum foil & Electrolyte paper

Name		Specification Sheet – WL	
Version	01	Page	5
STANDARD MANUAL			

MAN YUE ELECTRONICS COMPANY LIMITED	<i>ELECTROLYTIC CAPACITOR SPECIFICATION WL SERIES</i>	SAMXON	

4. Characteristics

Standard atmospheric conditions

Unless otherwise specified, the standard range of atmospheric conditions for making measurements and tests are as follows:

Ambient temperature	: 15°C to 35°C
Relative humidity	: 45% to 85%
Air Pressure	: 86kPa to 106kPa

If there is any doubt about the results, measurement shall be made within the following conditions:

Ambient temperature	: 20°C ± 2°C
Relative humidity	: 60% to 70%
Air Pressure	: 86kPa to 106kPa

Operating temperature range

The ambient temperature range at which the capacitor can be operated continuously at rated voltage
See table 1 temperature range.

As to the detailed information, please refer to table 2.

Name		Specification Sheet – WL	
Version	01	Page	6
STANDARD MANUAL			

Table 2

ITEM		PERFORMANCE								
4.1	Rated voltage (WV) Surge voltage (SV)	<table border="1" style="margin: auto; border-collapse: collapse;"> <tr> <td style="padding: 2px;">WV (V.DC)</td> <td style="padding: 2px;">350</td> <td style="padding: 2px;">400</td> <td style="padding: 2px;">450</td> </tr> <tr> <td style="padding: 2px;">SV (V.DC)</td> <td style="padding: 2px;">400</td> <td style="padding: 2px;">450</td> <td style="padding: 2px;">500</td> </tr> </table>	WV (V.DC)	350	400	450	SV (V.DC)	400	450	500
WV (V.DC)	350	400	450							
SV (V.DC)	400	450	500							
4.2	Nominal capacitance (Tolerance)	<p><Condition> Measuring Frequency : 120Hz ± 12Hz Measuring Voltage : Not more than 0.5Vrms Measuring Temperature : 20 ± 2°C</p> <p><Criteria> Shall be within the specified capacitance tolerance.</p>								
4.3	Leakage current	<p><Condition> Connecting the capacitor with a protective resistor (1kΩ ± 10Ω) in series for 2 minutes, and then, measure Leakage Current.</p> <p><Criteria> Refer to Table 1</p>								
4.4	tan δ	<p><Condition> See 4.2, Norm Capacitance, for measuring frequency, voltage and temperature.</p> <p><Criteria> Refer to Table 1</p>								

4.5	Terminal strength	<p><Condition> A torsion moment of 2.0N.m shall be applied to the screw in the axial direction away from the capacitor body for 10~15s.</p> <p><Criteria> There shall be no intermittent contacts, open or short circuit and there shall be no untight of screw.</p>																		
4.6	Temperature characteristic	<p><Condition></p> <table border="1" style="width: 100%; border-collapse: collapse;"> <thead> <tr> <th style="text-align: center;">STEP</th> <th style="text-align: center;">Testing Temperature(°C)</th> <th style="text-align: center;">Time</th> </tr> </thead> <tbody> <tr> <td style="text-align: center;">1</td> <td style="text-align: center;">20 ± 2</td> <td style="text-align: center;">Time to reach thermal equilibrium</td> </tr> <tr> <td style="text-align: center;">2</td> <td style="text-align: center;">$-25^{\circ}\text{C} \pm 3$</td> <td style="text-align: center;">Time to reach thermal equilibrium</td> </tr> <tr> <td style="text-align: center;">3</td> <td style="text-align: center;">20 ± 2</td> <td style="text-align: center;">Time to reach thermal equilibrium</td> </tr> <tr> <td style="text-align: center;">4</td> <td style="text-align: center;">85 ± 2</td> <td style="text-align: center;">Time to reach thermal equilibrium</td> </tr> <tr> <td style="text-align: center;">5</td> <td style="text-align: center;">20 ± 2</td> <td style="text-align: center;">Time to reach thermal equilibrium</td> </tr> </tbody> </table> <p><Criteria></p> <ul style="list-style-type: none"> * a. At +85°C, capacitance measured shall be within $\pm 20\%$ of its original value at +20°C. * Dissipation Factor shall be within the limit of Item 4.4 The leakage current measured shall not more than 5 times of its specified value. b. In step 5, Dissipation Factor shall be within the limit of Item 4.4 The leakage current shall not more than the specified value. 	STEP	Testing Temperature(°C)	Time	1	20 ± 2	Time to reach thermal equilibrium	2	$-25^{\circ}\text{C} \pm 3$	Time to reach thermal equilibrium	3	20 ± 2	Time to reach thermal equilibrium	4	85 ± 2	Time to reach thermal equilibrium	5	20 ± 2	Time to reach thermal equilibrium
STEP	Testing Temperature(°C)	Time																		
1	20 ± 2	Time to reach thermal equilibrium																		
2	$-25^{\circ}\text{C} \pm 3$	Time to reach thermal equilibrium																		
3	20 ± 2	Time to reach thermal equilibrium																		
4	85 ± 2	Time to reach thermal equilibrium																		
5	20 ± 2	Time to reach thermal equilibrium																		

4.6		<p>c. At -25°C, impedance (Z) ratio shall not exceed the value of the following table.</p> <table border="1" style="margin-left: auto; margin-right: auto;"> <tr> <td style="padding: 2px;">Working Voltage (V)</td> <td style="padding: 2px;">350~450</td> </tr> <tr> <td style="padding: 2px;">Z-25°C/Z+20°C</td> <td style="padding: 2px;">8</td> </tr> </table> <p>Capacitance D.F., and impedance shall be measured at 120Hz.</p>	Working Voltage (V)	350~450	Z-25°C/Z+20°C	8				
Working Voltage (V)	350~450									
Z-25°C/Z+20°C	8									
4.7	Load life test	<p><Condition> According to IEC60384-4No.4.13 methods, The capacitor is stored at a temperature of 85 ± 2 °C with DC bias voltage plus the rated ripple current for 20000 +48/0 hours.(The sum of DC and ripple peak voltage shall not exceed the rated working voltage) Then the product should be tested after 16 hours recovering time at atmospheric conditions. The result should meet the following table:</p> <p><Criteria> The characteristic shall meet the following requirements.</p> <table border="1" style="margin-left: auto; margin-right: auto;"> <tr> <td style="padding: 2px;">Leakage current</td> <td style="padding: 2px;">Value in 4.3 shall be satisfied</td> </tr> <tr> <td style="padding: 2px;">Capacitance Change</td> <td style="padding: 2px;">Within ± 30% of initial value .</td> </tr> <tr> <td style="padding: 2px;">Dissipation Factor</td> <td style="padding: 2px;">Not more than 300%of the specified value.</td> </tr> <tr> <td style="padding: 2px;">Appearance</td> <td style="padding: 2px;">There shall be no leakage of electrolyte.</td> </tr> </table>	Leakage current	Value in 4.3 shall be satisfied	Capacitance Change	Within ± 30% of initial value .	Dissipation Factor	Not more than 300%of the specified value.	Appearance	There shall be no leakage of electrolyte.
Leakage current	Value in 4.3 shall be satisfied									
Capacitance Change	Within ± 30% of initial value .									
Dissipation Factor	Not more than 300%of the specified value.									
Appearance	There shall be no leakage of electrolyte.									
4.8	Shelf life test	<p><Condition> The capacitors are then stored with no voltage applied at a temperature of 85 ± 2°C for 1000+48/0 hours. Following this period the capacitors shall be removed from the test chamber and be allowed to stabilized at room temperature for 4~8 hours. Next they shall be connected to a series limiting resistor(1k±100Ω) with D.C. rated voltage applied for 30min. After which the capacitors shall be discharged, and then, tested the characteristics.</p> <p><Criteria> The characteristic shall meet the following requirements.</p> <table border="1" style="margin-left: auto; margin-right: auto;"> <tr> <td style="padding: 2px;">Leakage current</td> <td style="padding: 2px;">Value in 4.3 shall be satisfied</td> </tr> <tr> <td style="padding: 2px;">Capacitance Change</td> <td style="padding: 2px;">Within ± 30% of initial value .</td> </tr> <tr> <td style="padding: 2px;">Dissipation Factor</td> <td style="padding: 2px;">Not more than 300%of the specified value.</td> </tr> <tr> <td style="padding: 2px;">Appearance</td> <td style="padding: 2px;">There shall be no leakage of electrolyte.</td> </tr> </table> <p>Remark: If the capacitors are stored more than 1 year, the leakage current may increase. Please apply voltage through about 1 kΩ resistor, if necessary.</p>	Leakage current	Value in 4.3 shall be satisfied	Capacitance Change	Within ± 30% of initial value .	Dissipation Factor	Not more than 300%of the specified value.	Appearance	There shall be no leakage of electrolyte.
Leakage current	Value in 4.3 shall be satisfied									
Capacitance Change	Within ± 30% of initial value .									
Dissipation Factor	Not more than 300%of the specified value.									
Appearance	There shall be no leakage of electrolyte.									

4.9	Surge test	<p><Condition> Applied a surge voltage to the capacitor connected with a (100 ±50)/C_R (kΩ) resistor. The capacitor shall be submitted to 1000 cycles, each consisting of charge of 30 ±5s, followed discharge of 5 min 30s. The test temperature shall be 15~35°C. C_R :Nominal Capacitance (μ F)</p> <p><Criteria></p> <table border="1" style="width: 100%; border-collapse: collapse;"> <tr> <td style="width: 50%;">Leakage current</td> <td>Not more than the specified value.</td> </tr> <tr> <td>Capacitance Change</td> <td>Within ± 15% of initial value .</td> </tr> <tr> <td>Dissipation Factor</td> <td>Not more than the specified value.</td> </tr> <tr> <td>Appearance</td> <td>There shall be no leakage of electrolyte.</td> </tr> </table> <p>Attention: This test simulates over voltage at abnormal situation, and not be hypothesizing that over voltage is always applied.</p>	Leakage current	Not more than the specified value.	Capacitance Change	Within ± 15% of initial value .	Dissipation Factor	Not more than the specified value.	Appearance	There shall be no leakage of electrolyte.
Leakage current	Not more than the specified value.									
Capacitance Change	Within ± 15% of initial value .									
Dissipation Factor	Not more than the specified value.									
Appearance	There shall be no leakage of electrolyte.									
4.10	Vibration test	<p><Condition> The following conditions shall be applied for 2 hours in each 3 mutually perpendicular directions. Vibration frequency range : 10Hz ~ 55Hz Peak to peak amplitude : 1.5mm Sweep rate : 10Hz ~ 55Hz ~ 10Hz in about 1 minute</p> <p><Criteria> After the test, the following items shall be tested:</p> <table border="1" style="width: 100%; border-collapse: collapse;"> <tr> <td style="width: 30%;">Appearance</td> <td>No mechanical damage in terminal. No leakage of electrolyte or swelling of the case. The markings shall be legible.</td> </tr> <tr> <td>Inner construction</td> <td>No intermittent contact, open or short circuit. No damage of tab terminals or electrodes.</td> </tr> </table> <p>Mounting method: The capacitor must be fixed in place with a bracket.</p>	Appearance	No mechanical damage in terminal. No leakage of electrolyte or swelling of the case. The markings shall be legible.	Inner construction	No intermittent contact, open or short circuit. No damage of tab terminals or electrodes.				
Appearance	No mechanical damage in terminal. No leakage of electrolyte or swelling of the case. The markings shall be legible.									
Inner construction	No intermittent contact, open or short circuit. No damage of tab terminals or electrodes.									

4.11	Change of temperature test	<p><Condition> Temperature Cycle: According to IEC60384-4 No.4.7 methods, capacitor shall be placed in an oven, the condition according as below:</p> <table border="1" style="width: 100%; border-collapse: collapse; margin-bottom: 10px;"> <thead> <tr> <th style="width: 70%;">Temperature</th> <th style="width: 30%;">Time</th> </tr> </thead> <tbody> <tr> <td>(1)+20°C</td> <td>≤3 Minutes</td> </tr> <tr> <td>(2)Rated low temperature (-25°C)</td> <td>30±2 Minutes</td> </tr> <tr> <td>(3)Rated high temperature (+85°C)</td> <td>30±2 Minutes</td> </tr> <tr> <td colspan="2">(1) to (3)=1 cycle, total 5 cycle</td> </tr> </tbody> </table> <p><Criteria> The characteristic shall meet the following requirement</p> <table border="1" style="width: 100%; border-collapse: collapse;"> <tr> <td style="width: 45%;">Leakage current</td> <td>Not more than the specified value.</td> </tr> <tr> <td>Dissipation Factor</td> <td>Not more than the specified value.</td> </tr> <tr> <td>Appearance</td> <td>There shall be no leakage of electrolyte.</td> </tr> </table>	Temperature	Time	(1)+20°C	≤3 Minutes	(2)Rated low temperature (-25°C)	30±2 Minutes	(3)Rated high temperature (+85°C)	30±2 Minutes	(1) to (3)=1 cycle, total 5 cycle		Leakage current	Not more than the specified value.	Dissipation Factor	Not more than the specified value.	Appearance	There shall be no leakage of electrolyte.
Temperature	Time																	
(1)+20°C	≤3 Minutes																	
(2)Rated low temperature (-25°C)	30±2 Minutes																	
(3)Rated high temperature (+85°C)	30±2 Minutes																	
(1) to (3)=1 cycle, total 5 cycle																		
Leakage current	Not more than the specified value.																	
Dissipation Factor	Not more than the specified value.																	
Appearance	There shall be no leakage of electrolyte.																	
4.12	Damp heat test	<p><Condition> Humidity Test: According to IEC60384-4 No.4.12 methods, capacitor shall be exposed for 500±8 hours in an atmosphere of 90~95%R H .at 40±2°C, the characteristic change shall meet the following requirement.</p> <p><Criteria></p> <table border="1" style="width: 100%; border-collapse: collapse;"> <tr> <td style="width: 45%;">Leakage current</td> <td>Not more than the specified value.</td> </tr> <tr> <td>Capacitance Change</td> <td>Within ±20% of initial value .</td> </tr> <tr> <td>Dissipation Factor</td> <td>Not more than 120% of the specified value.</td> </tr> <tr> <td>Appearance</td> <td>There shall be no leakage of electrolyte.</td> </tr> </table>	Leakage current	Not more than the specified value.	Capacitance Change	Within ±20% of initial value .	Dissipation Factor	Not more than 120% of the specified value.	Appearance	There shall be no leakage of electrolyte.								
Leakage current	Not more than the specified value.																	
Capacitance Change	Within ±20% of initial value .																	
Dissipation Factor	Not more than 120% of the specified value.																	
Appearance	There shall be no leakage of electrolyte.																	

4.13	Vent test	<p><Condition> The following test only apply to those products with vent. D.C. test The capacitor is connected with its polarity reversed to a DC power source. Then a current selected from Table 2 is applied.</p> <p><Table 2></p> <table border="1"> <thead> <tr> <th>Diameter (mm)</th> <th>DC Current (A)</th> </tr> </thead> <tbody> <tr> <td>Over 22.4</td> <td>10</td> </tr> </tbody> </table> <p><Criteria> The vent shall operate with no dangerous conditions such as flames or dispersion of pieces of the capacitor and/or case.</p>	Diameter (mm)	DC Current (A)	Over 22.4	10								
Diameter (mm)	DC Current (A)													
Over 22.4	10													
4.14	Maximum permissible (ripple current)	<p><Condition> The maximum permissible ripple current is the maximum A.C current at 120Hz and can be applied at maximum operating temperature</p> <p>Table-3 The combined value of D.C voltage and the peak A.C voltage shall not exceed the rated voltage and shall not reverse voltage. Frequency Multipliers:</p> <table border="1"> <thead> <tr> <th>Frequency (Hz)</th> <th>50</th> <th>120</th> <th>300</th> <th>1k</th> <th>10k~</th> </tr> </thead> <tbody> <tr> <td>≥160V</td> <td>0.80</td> <td>1.00</td> <td>1.08</td> <td>1.15</td> <td>1.20</td> </tr> </tbody> </table>	Frequency (Hz)	50	120	300	1k	10k~	≥160V	0.80	1.00	1.08	1.15	1.20
Frequency (Hz)	50	120	300	1k	10k~									
≥160V	0.80	1.00	1.08	1.15	1.20									

MAN YUE ELECTRONICS COMPANY LIMITED	ELECTROLYTIC CAPACITOR SPECIFICATION WL SERIES	SAMXON	

5. It refers to the latest document of “Environment-related Substances standard”(WI-HSPM-QA-072).

Substances	
Heavy metals	Cadmium and cadmium compounds
	Lead and lead compounds
	Mercury and mercury compounds
	Hexavalent chromium compounds
Chloinated organic compounds	Polychlorinated biphenyls (PCB)
	Polychlorinated naphthalenes (PCN)
	Polychlorinated terphenyls (PCT)
	Short-chain chlorinated paraffins(SCCP)
	Other chlorinated organic compounds
Brominated organic compounds	Polybrominated biphenyls (PBB)
	Polybrominated diphenylethers(PBDE) (including decabromodiphenyl ether[DecaBDE])
	Other brominated organic compounds
Tributyltin compounds(TBT)	
Triphenyltin compounds(TPT)	
Asbestos	
Specific azo compounds	
Formaldehyde	
Beryllium oxide	
Beryllium copper	
Specific phthalates (DEHP,DBP,BBP,DINP,DIDP,DNOP,DNHP)	
Hydrofluorocarbon (HFC), Perfluorocarbon (PFC)	
Perfluorooctane sulfonates (PFOS)	
Specific Benzotriazole	

Name		Specification Sheet – WL	
Version	01	Page	13
STANDARD MANUAL			

MAN YUE ELECTRONICS COMPANY LIMITED	<i>ELECTROLYTIC CAPACITOR SPECIFICATION WL SERIES</i>	SAMXON	

Attachment: Application Guidelines

1.Circuit Design

1.1 Operating Temperature and Frequency

Electrolytic capacitor electrical parameters are normally specified at 20°C temperature and 120Hz frequency. These parameters vary with changes in temperature and frequency. Circuit designers should take these changes into consideration.

- (1) Effects of operating temperature on electrical parameters
 - a) At higher temperatures, leakage current and capacitance increase while equivalent series resistance (ESR) decreases.
 - b) At lower temperatures, leakage current and capacitance decrease while equivalent series resistance (ESR) increases.
- (2) Effects of frequency on electrical parameters
 - a) At higher frequencies capacitance and impedance decrease while $\tan \delta$ increases.
 - b) At lower frequencies, ripple current generated heat will rise due to an increase in equivalent series resistance (ESR).

1.2 Operating Temperature and Life Expectancy

See the file: Life calculation of aluminum electrolytic capacitor

1.3 Common Application Conditions to Avoid

The following misapplication load conditions will cause rapid deterioration to capacitor electrical parameters. In addition, rapid heating and gas generation within the capacitor can occur causing the pressure relief vent to operate and resultant leakage of electrolyte. Under Leaking electrolyte is combustible and electrically conductive.

Name		Specification Sheet – WL		
Version	01		Page	14
STANDARD MANUAL				

MAN YUE ELECTRONICS COMPANY LIMITED	<i>ELECTROLYTIC CAPACITOR SPECIFICATION WL SERIES</i>	SAMXON	

(1) Reverse Voltage

DC capacitors have polarity. Verify correct polarity before insertion. For circuits with changing or uncertain polarity, use DC bipolar capacitors. DC bipolar capacitors are not suitable for use in AC circuits.

(2) Charge / Discharge Applications

Standard capacitors are not suitable for use in repeating charge / discharge applications. For charge / discharge applications consult us and advise actual conditions.

(3) Over voltage

Do not apply voltages exceeding the maximum specified rated voltage. Voltages up to the surge voltage rating are acceptable for short periods of time. Ensure that the sum of the DC voltage and the superimposed AC ripple voltage does not exceed the rated voltage.

(4) Ripple Current

Do not apply ripple currents exceeding the maximum specified value. For high ripple current applications, use a capacitor designed for high ripple currents or contact us with your requirements.

Ensure that allowable ripple currents superimposed on low DC bias voltages do not cause reverse voltage conditions.

1.4 Using Two or More Capacitors in Series or Parallel

(1) Capacitors Connected in Parallel

The circuit resistance can closely approximate the series resistance of the capacitor causing an imbalance of ripple current loads within the capacitors. Careful design of wiring methods can minimize the possibility of excessive ripple currents applied to a capacitor.

(2) Capacitors Connected in Series

Normal DC leakage current differences among capacitors can cause voltage imbalances. The use of voltage divider shunt resistors with consideration to leakage current can prevent capacitor voltage imbalances.

1.5 Capacitor Mounting Considerations

(1) Double Sided Circuit Boards

Avoid wiring pattern runs, which pass between the mounted capacitor and the circuit board.

When dipping into a solder bath, excess solder may collect under the capacitor by capillary action and short circuit the anode and cathode terminals.

(2) Circuit Board Hole Positioning

The vinyl sleeve of the capacitor can be damaged if solder passes through a lead hole for subsequently processed parts. Special care when locating hole positions in proximity to capacitors is recommended.

(3) Circuit Board Hole Spacing

The circuit board holes spacing should match the capacitor lead wire spacing within the specified tolerances.

Incorrect spacing can cause excessive lead wire stress during the insertion process. This may result in premature capacitor failure due to short or open circuit, increased leakage current, or electrolyte leakage.

Name		Specification Sheet – WL		
Version	01		Page	15
STANDARD MANUAL				

MAN YUE ELECTRONICS COMPANY LIMITED	<i>ELECTROLYTIC CAPACITOR SPECIFICATION WL SERIES</i>	SAMXON	

(4) Clearance for Case Mounted Pressure Relief vents

Capacitors with case mounted pressure relief vents require sufficient clearance to allow for proper vent operation. The minimum clearances are dependent on capacitor diameters as proper vent operation. The minimum clearances are dependent on capacitor diameters as follows.

ϕ 6.3~ ϕ 16mm:2mm minimum, ϕ 18~ ϕ 35mm:3mm minimum, ϕ 40mm or greater:5mm minimum.

(5) Clearance for Seal Mounted Pressure Relief Vents

A hole in the circuit board directly under the seal vent location is required to allow proper release of pressure.

(6) Wiring Near the Pressure Relief Vent

Avoid locating high voltage or high current wiring or circuit board paths above the pressure relief vent. Flammable, high temperature gas exceeding 100°C may be released which could dissolve the wire insulation and ignite.

(7) Circuit Board patterns Under the Capacitor

Avoid circuit board runs under the capacitor as electrolyte leakage could cause an electrical short.

(8) Screw Terminal Capacitor Mounting

Do not orient the capacitor with the screw terminal side of the capacitor facing downwards.

Tighten the terminal and mounting bracket screws within the torque range specified in the specification.

1.6 Electrical Isolation of the Capacitor

Completely isolate the capacitor as follows.

- (1) Between the cathode and the case (except for axially leaded B types) and between the anode terminal and other circuit paths
- (2) Between the extra mounting terminals (on T types) and the anode terminal, cathode terminal, and other circuit paths.

1.7 The Product endurance should take the sample as the standard.

1.8 If conduct the load or shelf life test, must be collect date code within 6 months products of sampling.

1.9 Capacitor Sleeve

The vinyl sleeve or laminate coating is intended for marking and identification purposes and is not meant to electrically insulate the capacitor.

The sleeve may split or crack if immersed into solvents such as toluene or xylene, and then exposed to high temperatures.

CAUTION!

Always consider safety when designing equipment and circuits. Plan for worst case failure modes such as short circuits and open circuits which could occur during use.

- (1) Provide protection circuits and protection devices to allow safe failure modes.
- (2) Design redundant or secondary circuits where possible to assure continued operation in case of main circuit failure.

Name		Specification Sheet – WL		
Version	01	Page	16	
STANDARD MANUAL				

MAN YUE ELECTRONICS COMPANY LIMITED	<i>ELECTROLYTIC CAPACITOR SPECIFICATION WL SERIES</i>	SAMXON

2.Capacitor Handling Techniques

2.1 Considerations Before Using

- (1) Capacitors have a finite life. Do not reuse or recycle capacitors from used equipment.
- (2) Transient recovery voltage may be generated in the capacitor due to dielectric absorption. If required, this voltage can be discharged with a resistor with a value of about 1k Ω .
- (3) Capacitors stored for long periods of time may exhibit an increase in leakage current. This can be corrected by gradually applying rated voltage in series with a resistor of approximately 1k Ω .
- (4) If capacitors are dropped, they can be damaged mechanically or electrically. Avoid using dropped capacitors.
- (5) Dented or crushed capacitors should not be used. The seal integrity can be compromised and loss of electrolyte / shortened life can result.

2.2 Capacitor Insertion

- * (1) Verify the correct capacitance and rated voltage of the capacitor.
- * (2) Verify the correct polarity of the capacitor before inserting.
- * (3) Verify the correct hole spacing before insertion (land pattern size on chip type) to avoid stress on the terminals.
- (4) Ensure that the auto insertion equipment lead clinching operation does not stress the capacitor leads where they enter the seal of the capacitor.

For chip type capacitors, excessive mounting pressure can cause high leakage current, short circuit, or disconnection.

2.3 Manual Soldering

- (1) Observe temperature and time soldering specifications or do not exceed temperatures of 400 °C for 3 seconds or less.
- (2) If lead wires must be formed to meet terminal board hole spacing, avoid stress on the lead wire where it enters the capacitor seal.
- (3) If a soldered capacitor must be removed and reinserted, avoid excessive stress to the capacitor leads.
- (4) Avoid touching the tip of the soldering iron to the capacitor, to prevent melting of the vinyl sleeve.

2.4 Flow Soldering

- (1) Do not immerse the capacitor body into the solder bath as excessive internal pressure could result.
- (2) Observe proper soldering conditions (temperature, time, etc.) Do not exceed the specified limits.
- (3) Do not allow other parts or components to touch the capacitor during soldering.

2.5 Other Soldering Considerations

Rapid temperature rises during the preheat operation and resin bonding operation can cause cracking of the capacitor vinyl sleeve.

For heat curing, do not exceed 150°C for a maximum time of 2 minutes.

Name		Specification Sheet – WL		
Version	01		Page	17
STANDARD MANUAL				

MAN YUE ELECTRONICS COMPANY LIMITED	<i>ELECTROLYTIC CAPACITOR SPECIFICATION WL SERIES</i>	SAMXON	

2.6 Capacitor Handling after Solder

- (1). Avoid movement of the capacitor after soldering to prevent excessive stress on the lead wires where they enter the seal.
- (2). Do not use capacitor as a handle when moving the circuit board assembly.
- (3). Avoid striking the capacitor after assembly to prevent failure due to excessive shock.

2.7 Circuit Board Cleaning

- * (1) Circuit boards can be immersed or ultrasonically cleaned using suitable cleaning solvents for up to 5 minutes and up to 60°C maximum temperatures. The boards should be thoroughly rinsed and dried.
The use of ozone depleting cleaning agents is not recommended in the interest of protecting the environment.
- * (2) Avoid using the following solvent groups unless specifically allowed for in the specification;
 - Halogenated cleaning solvents: except for solvent resistant capacitor types, halogenated solvents can permeate the seal and cause internal capacitor corrosion and failure. For solvent resistant capacitors, carefully follow the temperature and time requirements of the specification. 1-1-1 trichloroethane should never be used on any aluminum electrolytic capacitor.
 - Alkali solvents : could attack and dissolve the aluminum case.
 - Petroleum based solvents: deterioration of the rubber seal could result.
 - Xylene : deterioration of the rubber seal could result.
 - Acetone : removal of the ink markings on the vinyl sleeve could result.
- * (3) A thorough drying after cleaning is required to remove residual cleaning solvents which may be trapped between the capacitor and the circuit board. Avoid drying temperatures, which exceed the maximum rated temperature of the capacitor.
- * (4) Monitor the contamination levels of the cleaning solvents during use by electrical conductivity, pH, specific gravity, or water content. Chlorine levels can rise with contamination and adversely affect the performance of the capacitor.
Please consult us for additional information about acceptable cleaning solvents or cleaning methods.

2.8 Mounting Adhesives and Coating Agents

When using mounting adhesives or coating agents to control humidity, avoid using materials containing halogenated solvents. Also, avoid the use of chloroprene based polymers.
After applying adhesives or coatings, dry thoroughly to prevent residual solvents from being trapped between the capacitor and the circuit board.

3. Precautions for using capacitors

3.1 Environmental Conditions

Capacitors should not be stored or used in the following environments.

- * (1) Temperature exposure above the maximum rated or below the minimum rated temperature of the capacitor.
- * (2) Direct contact with water, salt water, or oil.
- * (3) High humidity conditions where water could condense on the capacitor.

Name		Specification Sheet – WL		
Version	01		Page	18
STANDARD MANUAL				

MAN YUE ELECTRONICS COMPANY LIMITED	<i>ELECTROLYTIC CAPACITOR SPECIFICATION WL SERIES</i>	SAMXON	

- * (4) Exposure to toxic gases such as hydrogen sulfide, sulfuric acid, nitric acid chlorine, or ammonia.
- * (5) Exposure to ozone, radiation, or ultraviolet rays.
- * (6) Vibration and shock conditions exceeding specified requirements.

3.2 Electrical Precautions

- (1) Avoid touching the terminals of the capacitor as possible electric shock could result. The exposed aluminum case is not insulated and could also cause electric shock if touched.
- (2) Avoid short circuit the area between the capacitor terminals with conductive materials including liquids such as acids or alkaline solutions.

4. Emergency Procedures

- (1) If the pressure relief vent of the capacitor operates, immediately turn off the equipment and disconnect from the power source. This will minimize additional damage caused by the vaporizing electrolyte.
- (2) Avoid contact with the escaping electrolyte gas which can exceed 100°C temperatures.
 If electrolyte or gas enters the eye, immediately flush the eyes with large amounts of water.
 If electrolyte or gas is ingested by mouth, gargle with water.
 If electrolyte contacts the skin, wash with soap and water.

5. Long Term Storage

Leakage current of a capacitor increases with long storage times. The aluminum oxide film deteriorates as a function of temperature and time. If used without reconditioning, an abnormally high current will be required to restore the oxide film. This current surge could cause the circuit or the capacitor to fail.

After one year, a capacitor should be reconditioned by applying rated voltage in series with a 1000 Ω ,current limiting resistor for a time period of 30 minutes .

If the expired date of products date code is over eighteen months, the products should be return to confirmation.

5.1 Environmental Conditions

The capacitor shall be not use in the following condition:

- (1) Temperature exposure above the maximum rated or below the minimum rated temperature of the capacitor.
- (2) Direct contact with water, salt water, or oil.
- (3) High humidity conditions where water could condense on the capacitor.
- (4) Exposure to toxic gases such as hydrogen sulfide, sulfuric acid, nitric acid, chlorine, or ammonia.
- (5) Exposure to ozone, radiation, or ultraviolet rays.
- (6) Vibration and shock conditions exceeding specified requirements.

6. Capacitor Disposal

When disposing of capacitors, use one of the following methods.

- * Incinerate after crushing the capacitor or puncturing the can wall (to prevent explosion due to internal pressure rise). Capacitors should be incinerated at high temperatures to prevent the release of toxic gases such as chlorine from the polyvinyl chloride sleeve, etc.
- * Dispose of as solid waste.

NOTE: Local laws may have specific disposal requirements, which must be followed.

Name		Specification Sheet – WL		
Version	01		Page	19
STANDARD MANUAL				