

## HJ Snap-in Terminal Type, Miniaturized Series

**M**  
Miniaturized



- Smaller case sizes than HC series
- High CV series
- Load life of 3000 hours at 85°C
- Voltage range of 160 ~ 450V
- Complied to the RoHS directive



Item	Characteristics													
Operating temperature range	WV < 350 : -40 ~ +85°C, WV $\geq$ 350 : -25 ~ +85°C													
Capacitance tolerance	$\pm 20\%$ at 120Hz, 20°C													
Leakage current max.	$I = 3\sqrt{CV}$ ( $\mu A$ ) (after 5 minutes)													
Dissipation factor max. (at 120Hz, 20°C)	Capacitance > 1000 $\mu F$ : $\tan\delta$ increases by 0.01 for each 1000 $\mu F$ from below value.													
	<table border="1"> <thead> <tr> <th>WV</th> <th>160</th> <th>200</th> <th>250</th> <th>350</th> <th>400</th> <th>450</th> </tr> </thead> <tbody> <tr> <td><math>\tan\delta</math></td> <td>0.15</td> <td>0.15</td> <td>0.15</td> <td>0.15</td> <td>0.15</td> <td>0.20</td> </tr> </tbody> </table>	WV	160	200	250	350	400	450	$\tan\delta$	0.15	0.15	0.15	0.15	0.15
WV	160	200	250	350	400	450								
$\tan\delta$	0.15	0.15	0.15	0.15	0.15	0.20								
Load life (after application of the rated voltage for 3000 hours at 85°C)	Leakage current	Less than specified value												
	Capacitance change	Within $\pm 20\%$ of initial value												
	$\tan\delta$	Less than 200% of specified value												
Shelf life (at 85°C)	After 1000 hours no load test, leakage current, capacitance and $\tan\delta$ are same as load life value.													

### ● DRAWING

Unit : mm

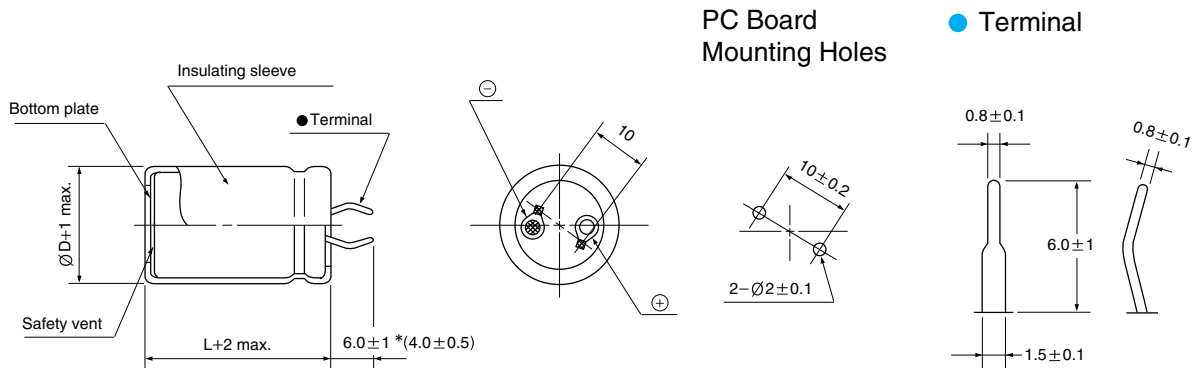

\* Shorter terminal(4.0 $\pm$ 0.5) is also available upon request.  
Terminal length of height 20mm products is applied shorter terminal to standard terminal type.

### ● FREQUENCY COEFFICIENT OF PERMISSIBLE RIPPLE CURRENT

$\mu F$ \ Frequency	50Hz	120Hz	300Hz	1kHz	10kHz~
160 ~ 250	0.85	1.00	1.20	1.25	1.45
300 ~	0.85	1.00	1.15	1.20	1.40

# LARGE ALUMINUM ELECTROLYTIC CAPACITORS

**HJ** series

## ● DIMENSIONS & MAXIMUM PERMISSIBLE RIPPLE CURRENT

WV μF / ØD	160				200				250			
	22	25.4	30	35	22	25.4	30	35	22	25.4	30	35
150									22 × 20 0.83			
180					22 × 20 0.91				22 × 20 0.91			
220					22 × 20 1.01				22 × 25 1.09	25.4 × 20 1.11		
270	22 × 20 1.12				22 × 25 1.20	25.4 × 20 1.23			22 × 25 1.20	25.4 × 25 1.32		
330	22 × 25 1.33	25.4 × 20 1.36			22 × 25 1.33	25.4 × 20 1.36			22 × 30 1.42	25.4 × 25 1.46	30 × 20 1.49	
390	22 × 25 1.45	25.4 × 20 1.48			22 × 25 1.45	25.4 × 25 1.59	30 × 20 1.62		22 × 35 1.63	25.4 × 30 1.69	30 × 25 1.73	35 × 20 1.77
470	22 × 30 1.69	25.4 × 25 1.75			22 × 30 1.69	25.4 × 25 1.75	30 × 20 1.78		22 × 35 1.79	25.4 × 35 1.96	30 × 25 1.90	35 × 20 1.94
560	22 × 30 1.85	25.4 × 25 1.91	30 × 20 1.94		22 × 35 1.96	25.4 × 30 2.03	30 × 25 2.08	35 × 20 2.12	22 × 40 2.06	25.4 × 35 2.14	30 × 25 2.08	35 × 25 2.25
680	22 × 35 2.16	25.4 × 30 2.23	30 × 25 2.29	35 × 20 2.33	22 × 40 2.27	25.4 × 30 2.23	30 × 25 2.29	35 × 25 2.33	22 × 50 2.49	25.4 × 40 2.48	30 × 30 2.43	35 × 25 2.48
820	22 × 40 2.50	25.4 × 30 2.45	30 × 25 2.52	35 × 20 2.56	22 × 45 2.61	25.4 × 35 2.59	30 × 30 2.67	35 × 25 2.73		25.4 × 45 2.85	30 × 35 2.81	35 × 30 2.88
1000	22 × 45 2.89	25.4 × 35 2.86	30 × 30 2.95	35 × 25 3.01	22 × 50 3.01	25.4 × 40 3.01	30 × 35 3.11	35 × 30 3.18			30 × 40 3.26	35 × 35 3.35
1200	22 × 50 3.09	25.4 × 40 3.08	30 × 30 3.02	35 × 25 3.08		25.4 × 45 3.23	30 × 35 3.18	35 × 30 3.26			30 × 45 3.49	35 × 35 3.43
1500		25.4 × 45 3.61	30 × 35 3.56	35 × 30 3.65			30 × 45 3.90	35 × 35 3.83				35 × 40 4.01
1800			30 × 40 4.09	35 × 35 4.20			30 × 50 4.44	35 × 40 4.39				35 × 50 4.76
2200			30 × 50 4.63	35 × 40 4.58				35 × 45 4.77				
2700				35 × 45 5.29								
3300				35 × 50 5.77								

WV μF / ØD	350				400				450			
	22	25.4	30	35	22	25.4	30	35	22	25.4	30	35
56									22 × 20 0.51			
68					22 × 20 0.56				22 × 20 0.56			
82					22 × 20 0.62				22 × 25 0.66	25.4 × 20 0.68		
100	22 × 20 0.68				22 × 25 0.73	25.4 × 20 0.75			22 × 25 0.73	25.4 × 25 0.81		
120	22 × 25 0.80	25.4 × 20 0.82			22 × 25 0.80	25.4 × 20 0.82			22 × 30 0.86	25.4 × 25 0.88	30 × 20 0.90	
150	22 × 25 0.90	25.4 × 25 0.92			22 × 30 0.90	25.4 × 25 0.99	30 × 20 1.01		22 × 35 1.01	25.4 × 30 1.05	30 × 25 1.08	35 × 20 1.10
180	22 × 30 1.05	25.4 × 25 1.08			22 × 30 1.05	25.4 × 25 1.08	30 × 25 1.10		22 × 35 1.11	25.4 × 35 1.21	30 × 25 1.18	35 × 20 1.20
220	22 × 30 1.16	25.4 × 30 1.19	30 × 25 1.22		22 × 35 1.23	25.4 × 30 1.27	30 × 25 1.30	35 × 20 1.33	22 × 40 1.29	25.4 × 35 1.34	30 × 25 1.30	35 × 25 1.41
270	22 × 35 1.36	25.4 × 30 1.41	30 × 25 1.44	35 × 20 1.47	22 × 40 1.43	25.4 × 35 1.49	30 × 30 1.44	35 × 25 1.47	22 × 50 1.57	25.4 × 40 1.56	30 × 30 1.53	35 × 25 1.56
330	22 × 45 1.58	25.4 × 35 1.56	30 × 30 1.60	35 × 25 1.62	22 × 50 1.66	25.4 × 40 1.64	30 × 30 1.69	35 × 25 1.73		25.4 × 45 1.81	30 × 35 1.78	35 × 30 1.83
390	22 × 50 1.80	25.4 × 40 1.79	30 × 30 1.84	35 × 25 1.88		25.4 × 45 1.88	30 × 35 1.94	35 × 30 1.99			30 × 40 2.03	35 × 35 2.09
470		25.4 × 45 2.06	30 × 35 2.02	35 × 30 2.06		25.4 × 50 2.16	30 × 40 2.23	35 × 30 2.18			30 × 45 2.33	35 × 35 2.29
560		25.4 × 50 2.46	30 × 40 2.32	35 × 35 2.38			30 × 45 2.55	35 × 35 2.50				35 × 40 2.62
680			30 × 45 2.69	35 × 35 2.76			30 × 50 2.92	35 × 40 2.89				35 × 50 3.13
820				35 × 40 3.17				35 × 50 3.31	← Case size ØD × L (mm) ← Ripple current (Arms) at 85°C, 120Hz			
1000				35 × 45 3.65								