Chip Resistor



Chip Resistor

■ INTRODUCTION

Chip resistors are general passive component which is useful for derating voltage, current controlling in circuit and surface mounting is available.

Samsung electro mechanics also manufactures a wide range of chip resistors such as general, precision, trimmable and low ohms and so on.

Production is increasing with demand for small size & light weight of set product. We provide ultra-small, high-reliability, high-stability resistors.

We have obtained ISO-9002 and QS-9000 certification.

■ FEATURE AND APPLICATION

● Feature

- Very small, thin, and light weight.
- Both flow and reflow soldering are applicable.
- Owing to the reduced lead inductance, the high frequency characteristic is excellent.
- Suitable size and packaging for surface mount assembly.
- Reel type and Bulk type Packaging are applicable.

● Application

- General purpose.
- Home Appliances.
(DVD, Digital TV, Camcorder, VTR, Digital Camera, Audio, Tunner)
- For Computers & Communication Devices.
(Notebook, Memory Module, Mobile, Network Equipment, etc)

Chip Resistor

■ STRUCTURE

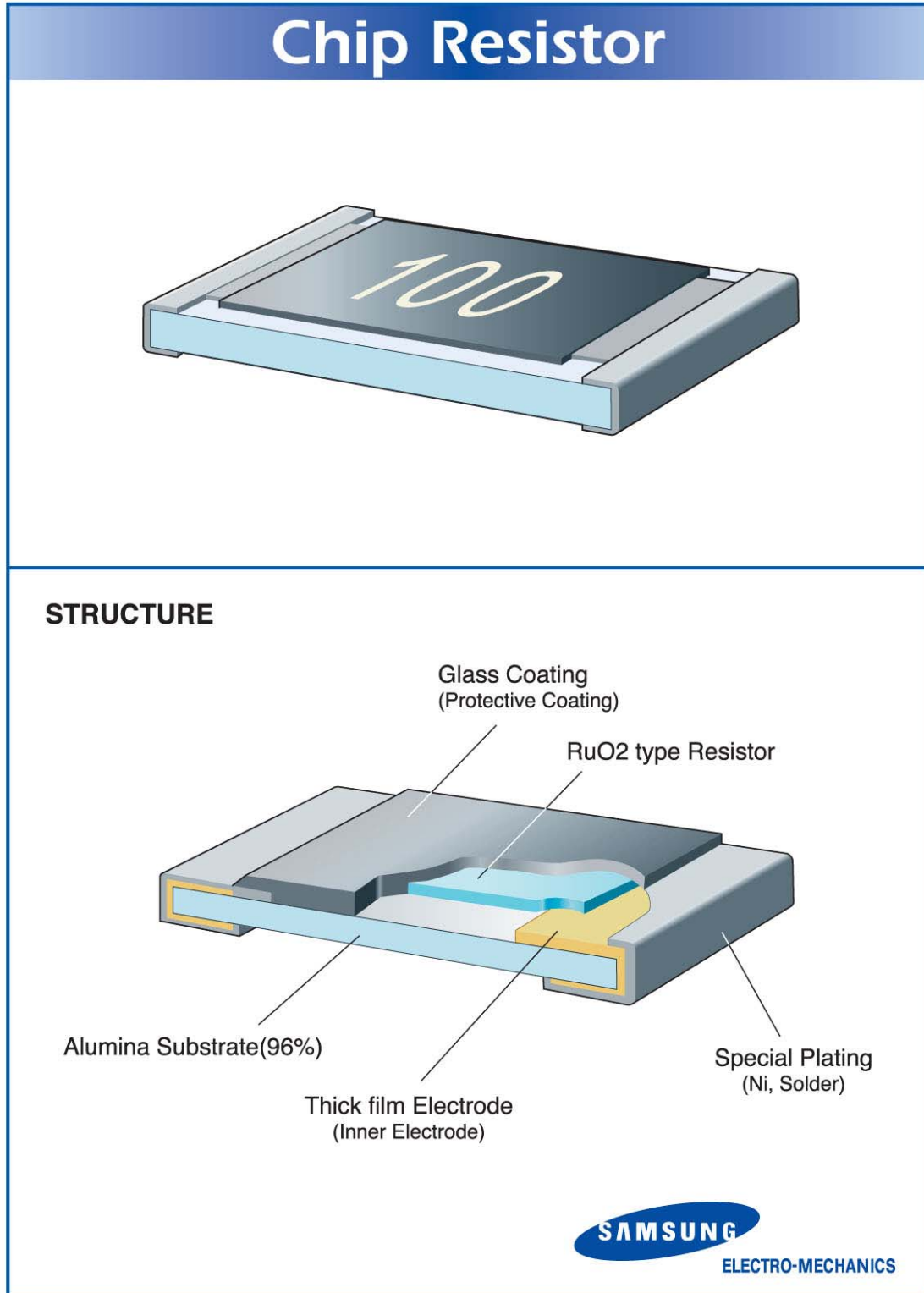

Chip Resistor

■ APPEARANCE AND DIMENSION

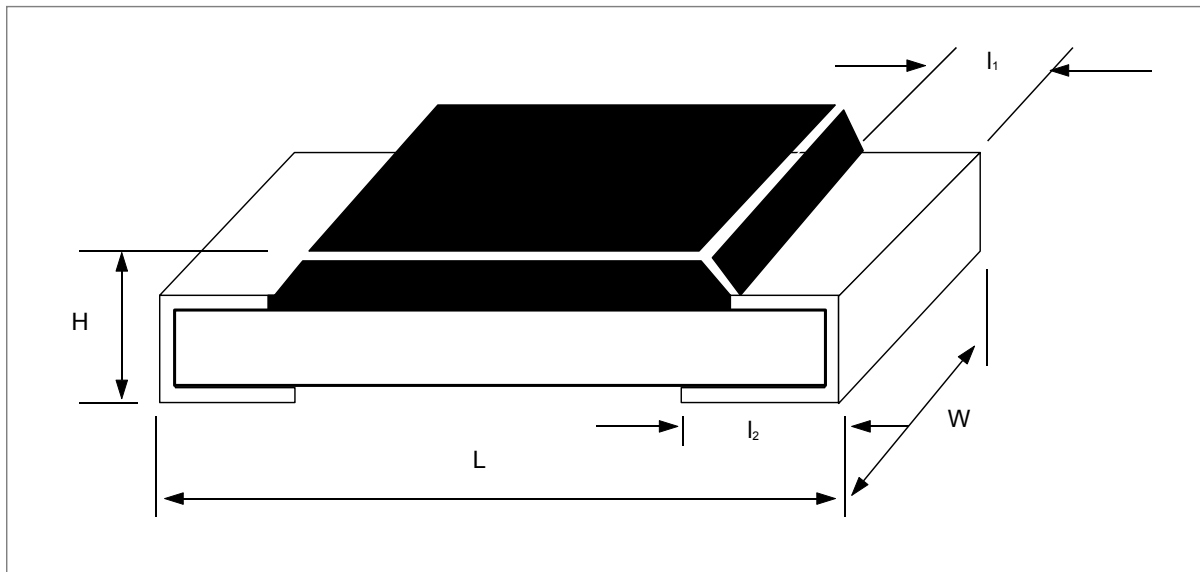

[Unit : mm]

| TYPE | inch | Power (W) | L | W | H | l_1 | l_2 | Unit Weight |
|------|------|-----------|-----------------|-----------------|-----------------|-----------------|-----------------|-------------|
| 0603 | 0201 | 1/20 | 0.60 ± 0.03 | 0.30 ± 0.03 | 0.23 ± 0.05 | 0.15 ± 0.05 | 0.15 ± 0.05 | 0.16mg |
| 1005 | 0402 | 1/16 | 1.00 ± 0.05 | 0.50 ± 0.05 | 0.35 ± 0.05 | 0.20 ± 0.10 | 0.25 ± 0.10 | 0.6mg |
| 1608 | 0603 | 1/10 | 1.60 ± 0.10 | 0.80 ± 0.15 | 0.45 ± 0.10 | 0.30 ± 0.20 | 0.35 ± 0.20 | 2.1mg |
| 2012 | 0805 | 1/8 | 2.00 ± 0.20 | 1.25 ± 0.15 | 0.50 ± 0.10 | 0.40 ± 0.20 | 0.35 ± 0.20 | 4.9mg |
| 3216 | 1206 | 1/4 | 3.20 ± 0.20 | 1.60 ± 0.15 | 0.55 ± 0.10 | 0.45 ± 0.20 | 0.40 ± 0.20 | 9.5mg |
| 3225 | 1210 | 1/4 | 3.20 ± 0.20 | 2.55 ± 0.20 | 0.55 ± 0.10 | 0.45 ± 0.20 | 0.40 ± 0.20 | 16mg |
| 5025 | 2010 | 1/2 | 5.00 ± 0.15 | 2.50 ± 0.15 | 0.55 ± 0.15 | 0.60 ± 0.20 | 0.60 ± 0.20 | 26mg |
| 6432 | 2512 | 1 | 6.30 ± 0.15 | 3.20 ± 0.15 | 0.55 ± 0.15 | 0.60 ± 0.20 | 0.60 ± 0.20 | 41mg |

Chip Resistor

■ PART NUMBERING

| | | | | |
|-----------|-------------|----------|------------|-----------|
| RC | 2012 | J | 100 | CS |
| ① | ② | ③ | ④ | ⑤ |

① CODE DESIGNATION

RC : This code expresses the Resistor that is produced by Samsung Electro-Mechanics CO.LTD. (with the exception of Trimmable Chip Resistor(RT))

② DIMENSION

The dimension is expressed as 4 digits number by SI unit (mm). <Table 1>
Left 2 digits are length of resistor, and the other 2 digits are width. <Fig 1>

<Fig 1>

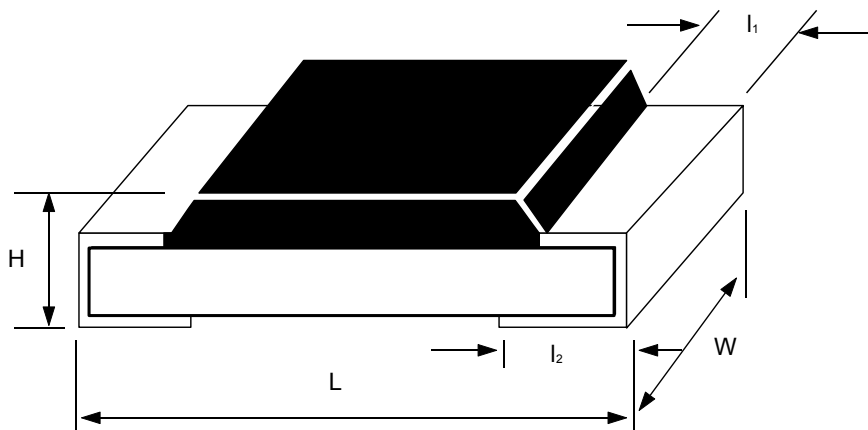

<Table 1>

[Unit : mm]

| Dimension (inch) | 0603 (0201) | 1005 (0402) | 1608 (0603) | 2012 (0805) | 3216 (1206) | 3225 (1210) | 5025 (2010) | 6432 (2512) |
|---------------------|----------------|----------------|----------------|----------------|----------------|----------------|----------------|----------------|
| L | 0.60±0.03 | 1.00±0.05 | 1.60 ± 0.10 | 2.00 ± 0.20 | 3.20 ± 0.20 | 3.20 ± 0.20 | 5.00 ± 0.15 | 6.30 ± 0.15 |
| W | 0.30±0.03 | 0.50±0.05 | 0.80 ± 0.15 | 1.25 ± 0.15 | 1.60 ± 0.15 | 2.55 ± 0.20 | 2.50 ± 0.15 | 3.20 ± 0.15 |
| H | 0.23±0.05 | 0.35±0.05 | 0.45 ± 0.10 | 0.50 ± 0.10 | 0.55 ± 0.10 | 0.55 ± 0.10 | 0.55 ± 0.10 | 0.55 ± 0.10 |
| l ₁ | 0.15±0.05 | 0.20±0.10 | 0.30 ± 0.20 | 0.40 ± 0.20 | 0.45 ± 0.20 | 0.45 ± 0.20 | 0.60 ± 0.20 | 0.60 ± 0.20 |
| l ₂ | 0.15±0.05 | 0.25±0.10 | 0.35 ± 0.10 | 0.35 ± 0.20 | 0.40 ± 0.20 | 0.40 ± 0.20 | 0.60 ± 0.20 | 0.60 ± 0.20 |

Chip Resistor

③ RESISTANCE TOLERANCE

The Resistance Tolerance is expressed as 1 digit alphabet by EIAJ standard. <Table 2>

<Table 2>

| Item | F | G | J | K | L | M |
|------------------|------------|------|------|---------|------|------|
| Tolerance (%) | ± 1 | ± 2 | ± 5 | ± 10 | ± 15 | ± 20 |
| Producing Series | E-24, E-96 | E-48 | E-24 | E-12 | E-9 | E-6 |
| Type | P, L | G, L | G, L | G, L, T | T | T |

Type Representation : G(General), P(Precision), L(Low ohms), T(Trimmable)

④ NOMINAL RESISTANCE VALUE

The Nominal Resistance Value is expressed as 3 or 4 digits by EIAJ standard. <Table 3>

<Table 3>

| Item | 3 Digits mark | 4 Digits mark |
|-----------------------|----------------------------------------------------------------------------------------------------------------|---------------------------------------------------------------------------------------------------|
| Resistance Tolerance | F, G, J, K, L, M | F, G |
| Only number | Left 2 digits : Resistance value Right 1 digit : Exponential number of 10. | Left 3 digits : Resistance value Right 1 digit : Exponential number of 10. |
| Number & alphabet "R" | Read alphabet "R" as decimal point. | Read alphabet "R" as decimal point. |
| Example | 1) 101 : $10 \times 10^1 = 10 \times 10 = 100 \Omega$ 2) 7R5 : $7.5 = 7.5 \Omega$ 3) R75 : 0.75Ω | 1) 1001 : $100 \times 10^1 = 100 \times 10 = 1 \text{ k}\Omega$ 2) 9R09 : $9.09 = 9.09 \Omega$ |

If resistance value in E-96 is same resistance value in E-24, we mark 3 or 4 digits on the resistor.

In case of JUMPER(0 ohm), '000' is marked on that resistor.

Chip Resistor

⑤ PACKAGING CODE

The Packaging Code is expressed as 2 digits alphabet. <Table 4>

<Table 4>

| Packaging Code | Description | Dimension | Packaging Q'ty |
|----------------|---------------------|------------------------|----------------|
| C S | 7" REEL PACKAGING | 0603, 1005 | 10,000 PCS |
| | | 1608, 2012, 3216, 3225 | 5,000 PCS |
| | | 5025, 6432 | 4,000 PCS |
| E S | 10" REEL PACKAGING | 1608, 2012, 3216 | 10,000 PCS |
| A S | 13" REEL PACKAGING | 0603, 1005 | 40,000 PCS |
| | | 1608, 2012, 3216, 3225 | 20,000 PCS |
| | | 5025, 6432 | 15,000 PCS |
| G S | BULK CASE PACKAGING | 1608 | 25,000 PCS |
| | | 2012 | 10,000 PCS |
| | | 3216 | 5,000 PCS |

Chip Resistor

■ PACKAGING

● PACKAGING METHOD

Packaging protects the resistor from damage during the shipping or storage.
There are two types of packaging method ; one is "Reel" type, and the other is "Bulk" type.

● REEL TYPE PACKAGING SPECIFICATION

The packaging specification is based on the EIAJ RC-1009.

<Fig 2> is tape dimension For 0603, 1005 type. <Table 5> is for pocket sizes, A and B.

<Fig 2>

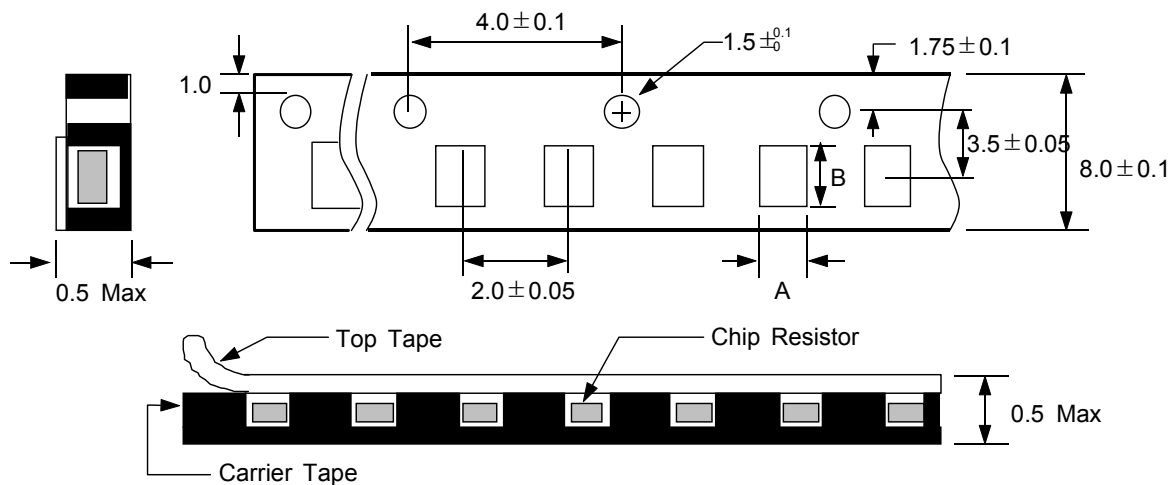

Chip Resistor

<Fig 3> is tape dimension For 1608, 2012, 3216, 3225 type. <Table 5> is for pocket sizes, A and B.

<Fig 3>

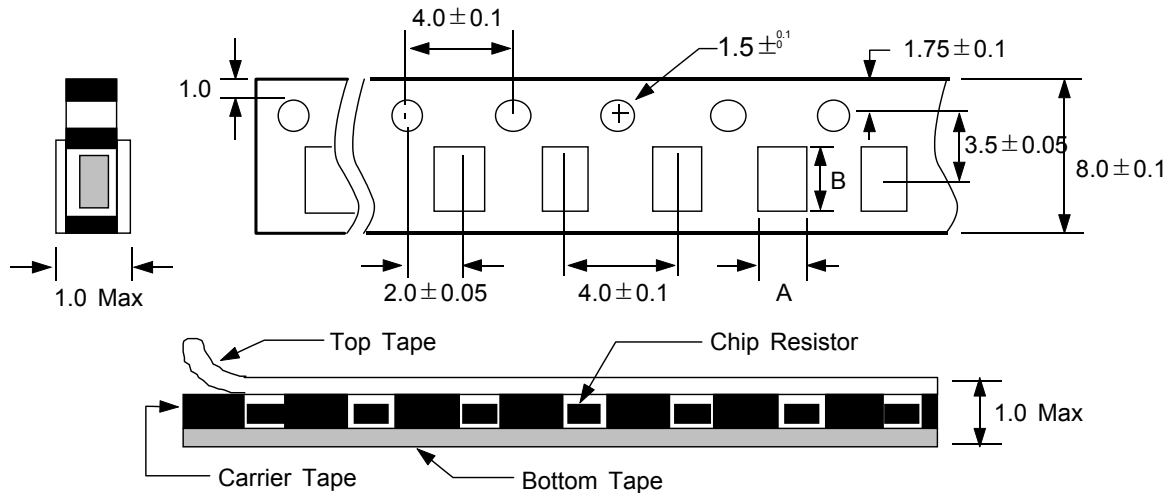

<Fig 4> is tape dimension For 5025, 6432 type. <Table 5> is for pocket sizes, A and B.

<Fig 4>

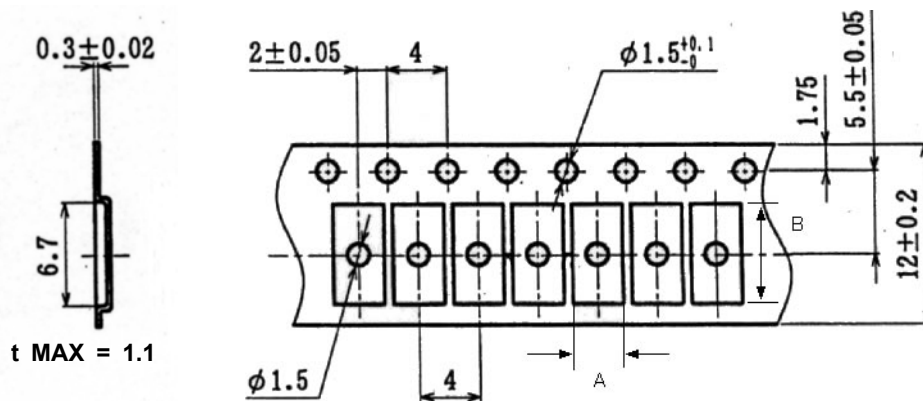

<Table 5>

| Dimension | 0603 | 1005 | 1608 | 2012 | 3216 | 3225 | 5025 | 6432 |
|-----------|-------------|-------------|-------------|-------------|-------------|-------------|-------------|-------------|
| Symbol | (0201) | (0402) | (0603) | (0805) | (1206) | (1210) | (2010) | (2512) |
| A | 0.65 ± 0.10 | 0.70 ± 0.10 | 1.10 ± 0.20 | 1.65 ± 0.20 | 2.00 ± 0.20 | 2.90 ± 0.20 | 2.80 ± 0.10 | 3.50 ± 0.10 |
| B | 1.15 ± 0.10 | 1.20 ± 0.10 | 1.90 ± 0.20 | 2.40 ± 0.20 | 3.60 ± 0.20 | 3.60 ± 0.20 | 5.30 ± 0.20 | 6.75 ± 0.10 |

Chip Resistor

● TAPING METHOD

There are empty holes at both start part and end part of carrier tape. <Fig 5>

<Fig 5>

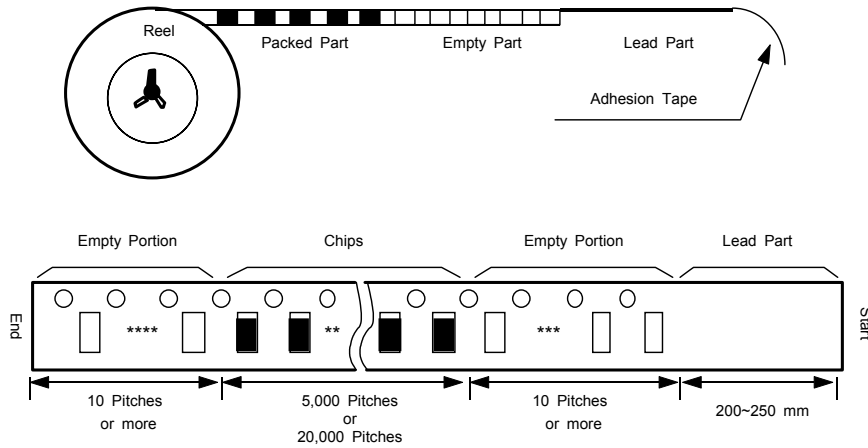

Note

- ① The resistor should move in the pocket freely.
- ② The resistor should not adhere to the top or bottom tape.
- ③ There should be no vacant pocket.
- ④ Peeling strength of the top tape should be within 5g and 80g. <Fig 6>

<Fig 6>

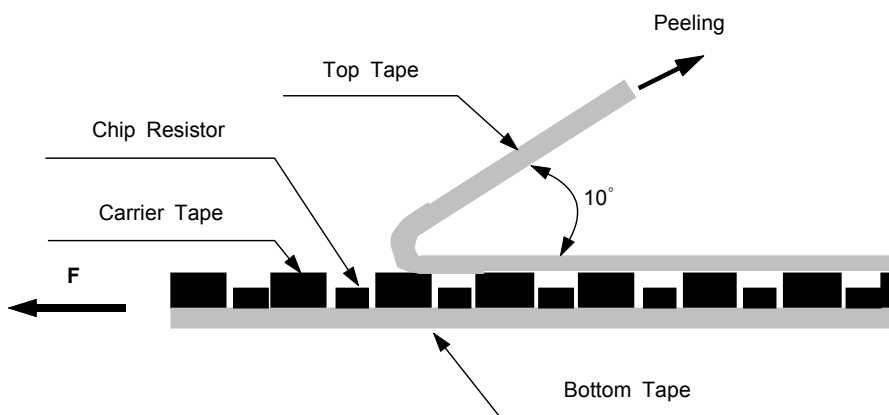

Chip Resistor

● REEL DIMENSION

The Reel dimension is classified by the diameter of Reel. <Fig 7> <Table 6>

<Fig 7>

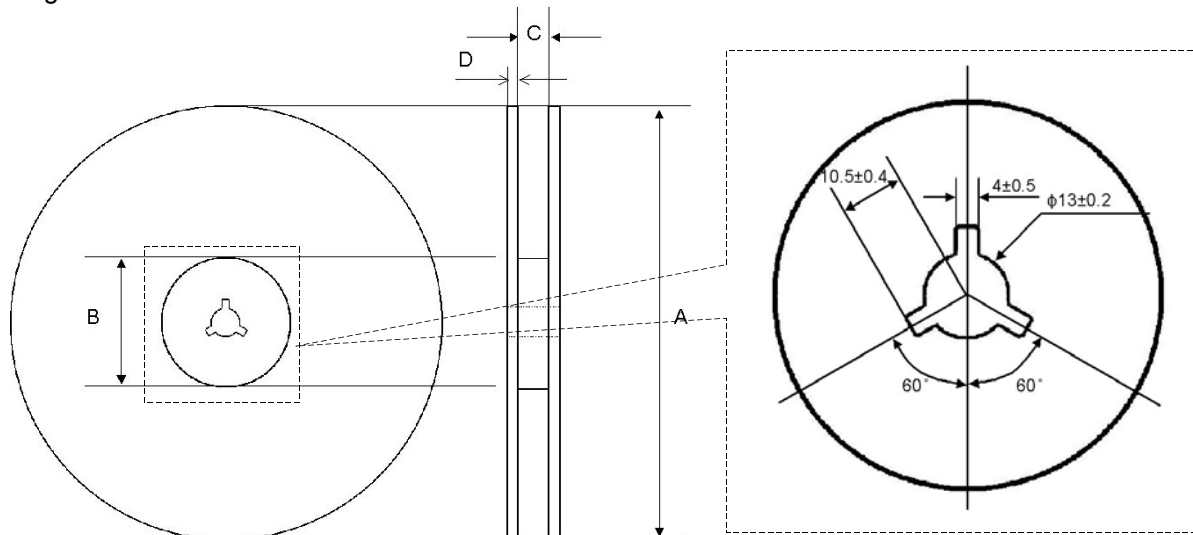

< Table 6 >

[Unit : mm]

| Packaging Code | Diameter | A | B | C | D |
|----------------|----------|-----|------|-----------------|-----------|
| C S | 7" | 178 | Φ 70 | 9.5(13.0) ± 0.1 | 1.2 ± 0.1 |
| E S | 10" | 258 | Φ 80 | 9.5 ± 0.1 | 2.0 ± 0.1 |
| F S, A S | 13" | 330 | Φ 80 | 9.5 ± 0.1 | 2.0 ± 0.1 |

● BULK TYPE PACKAGING

Bulk cassette specification is based on the EIAJ ET-7201. <Fig 8>

The standard packaging quantity depends on the dimension. <Table 7>

<Fig 8>

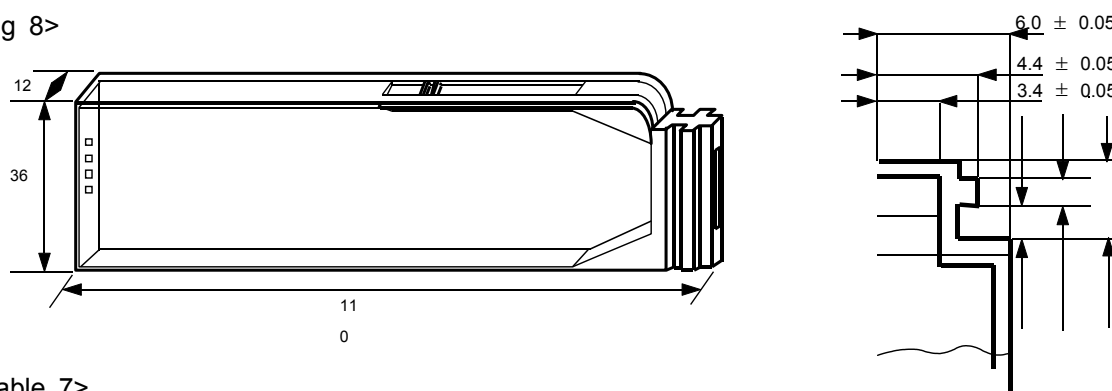

<Table 7>

| Dimension | Inch | Standard packaging quantity | Weight (g, avg.) |
|-----------|------|-----------------------------|------------------|
| 1608 | 0603 | 25,000 PCS | 71 |
| 2012 | 0805 | 10,000 PCS | 65 |
| 3216 | 1206 | 5,000 PCS | 67 |

Chip Resistor

● LABELING

▶ Reel type Label

The reel type label includes following contents as <Fig 9>.

- Following -

- ① Resistance Value
- ② Tolerance, Marking
- ③ Part Number
- ④ Quantity
- ⑤ LOT Number
- ⑥ Bar - Code
- ⑦ Serial Number

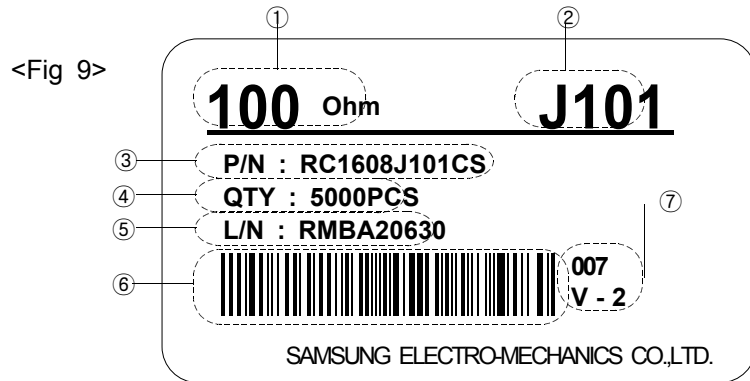

▶ Bulk type Label

The bulk type label includes following contents as <Fig 10>.

- Following -

- ① Part Number
- ② Resistance Value
- ③ LOT Number
- ④ Quantity
- ⑤ Bar - Code
- ⑥ Serial Number

<Fig 10>

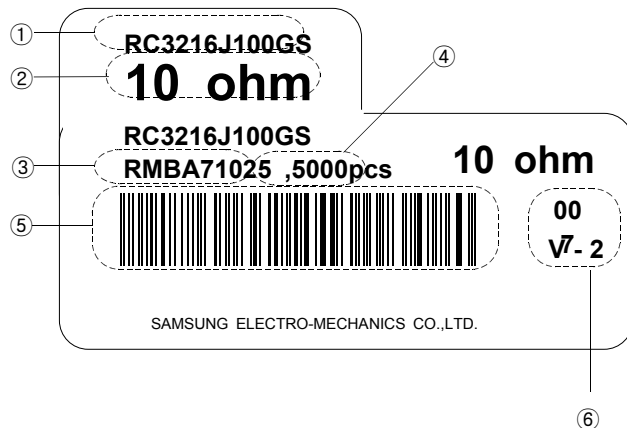

● BOX PACKAGING METHOD

- ① The bulk or reel type packaging is packaged twice by paper box, inner box and outer box.
- ② The packaging should protect the resistor from damaging during shipping by vehicle, ship, airplane and etc.
- ③ The information of contents is marked on both inner and outer box.

※ For other packaging methods, please contact us.

Chip Resistor

● BOX DIMENSION FOR REEL TYPE

① Max 25,000 pcs (5 EA × 7")

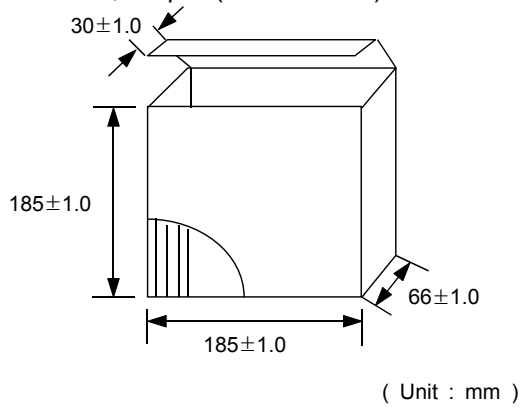

② Max 100,000 pcs (20 EA × 7")

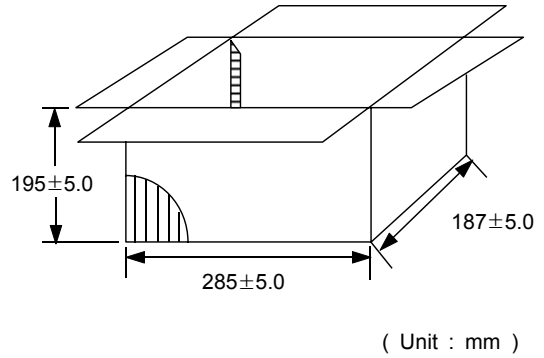

③ Max 300,000 pcs (60 EA × 7")

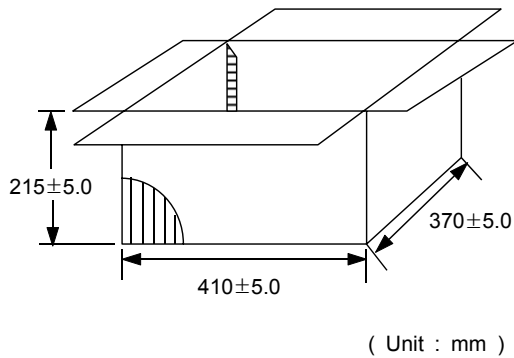

④ Max 400,000 pcs (20 EA × 13")

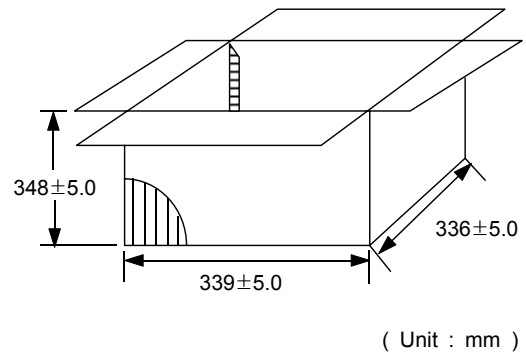

● BOX DIMENSION FOR BULK TYPE

① Inner box (Cassette × 5 EA)

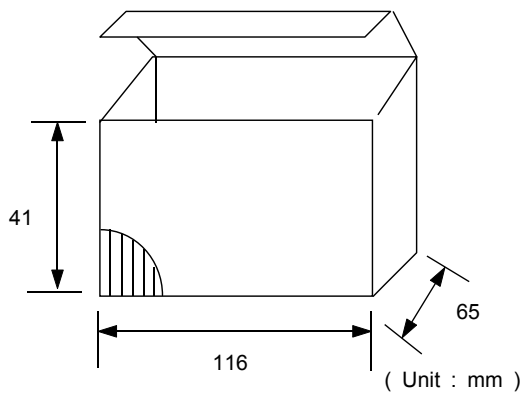

② Outer box (Inner box × 20 EA)

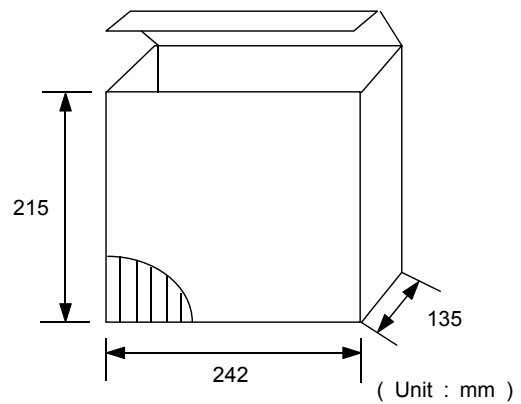

Chip Resistor

RELIABILITY TEST DATA

Jumper's reliability test data are only applied to General type resistor.

ELECTRICAL CHARACTERISTIC

The electrical characteristic test should satisfy the test method, procedure, and standard.
 If there is no special comment, Each test performs in standard state.
 (temperature 20°C, humidity 65%RH, pressure 1023mbar)

| item | Permissible deviation | | Test method | | | | | | | | | | | | | | | | | | | | | | | | | | | | | | |
|---------------------------------------|--------------------------------------------------------------------------------------------------------------------------------------------------------------------------------------------------------------------------------------------------------------------------------------------------------------------------------------------------------------------------------------------------------------------------------------------------------------------------------------------------------------------------------------------------------------------------------------------------------------------------------------------------------------------------------------------------------------------------------------------------------------------------------------------------------|-----------------|----------------------------------------------------------------------------------------------------------------------------------------------------------------------------------------------------------------------------------------------------------------------------------------------------------------------------------------------------------------------------------------------------------------------------------------------------------------------------------------------------------------------------------------------------------------------------------------------------------------------------------------------------------------------------------------------------------|-----------|-------------|-------|-----|--------|-----|--------------|---------|--------------|-----|--------------|------|----------------|---------|---------------|------|---------|---------|----------|--------|-------------|-------------|------------|------------|-------------|------|--------------|------|---|---------------------------------------------------------------------------------------------------------------------------------------------------------------------------------------------------------------------------------------------------------------------------------------------------------------------------------------------------------------------------------------------------------------------------------------------------------------------------|
| | Resistor | Jumper | | | | | | | | | | | | | | | | | | | | | | | | | | | | | | | |
| DC resistance | DC resistance value should be within the specified resistance tolerance. | 50mΩ Maximum | <ul style="list-style-type: none"> Standard : JIS C 5202 (5.1) Test voltage : <Table 8> Applying time : within 5 seconds. Test board : <Fig 11> <table border="1"> <thead> <tr> <th>Range (Ω)</th> <th>Voltage (V)</th> </tr> </thead> <tbody> <tr> <td>R < 1</td> <td>0.1</td> </tr> <tr> <td>R < 10</td> <td>0.1</td> </tr> <tr> <td>10 ≤ R < 100</td> <td>0.3</td> </tr> <tr> <td>100 ≤ R < 1K</td> <td>1.0</td> </tr> <tr> <td>1K ≤ R < 10K</td> <td>3.0</td> </tr> <tr> <td>10K ≤ R < 100K</td> <td>10</td> </tr> <tr> <td>100K ≤ R < 1M</td> <td>25</td> </tr> <tr> <td>1M ≤ R</td> <td>50</td> </tr> </tbody> </table> | Range (Ω) | Voltage (V) | R < 1 | 0.1 | R < 10 | 0.1 | 10 ≤ R < 100 | 0.3 | 100 ≤ R < 1K | 1.0 | 1K ≤ R < 10K | 3.0 | 10K ≤ R < 100K | 10 | 100K ≤ R < 1M | 25 | 1M ≤ R | 50 | | | | | | | | | | | | |
| Range (Ω) | Voltage (V) | | | | | | | | | | | | | | | | | | | | | | | | | | | | | | | | |
| R < 1 | 0.1 | | | | | | | | | | | | | | | | | | | | | | | | | | | | | | | | |
| R < 10 | 0.1 | | | | | | | | | | | | | | | | | | | | | | | | | | | | | | | | |
| 10 ≤ R < 100 | 0.3 | | | | | | | | | | | | | | | | | | | | | | | | | | | | | | | | |
| 100 ≤ R < 1K | 1.0 | | | | | | | | | | | | | | | | | | | | | | | | | | | | | | | | |
| 1K ≤ R < 10K | 3.0 | | | | | | | | | | | | | | | | | | | | | | | | | | | | | | | | |
| 10K ≤ R < 100K | 10 | | | | | | | | | | | | | | | | | | | | | | | | | | | | | | | | |
| 100K ≤ R < 1M | 25 | | | | | | | | | | | | | | | | | | | | | | | | | | | | | | | | |
| 1M ≤ R | 50 | | | | | | | | | | | | | | | | | | | | | | | | | | | | | | | | |
| Temperature Coefficient of Resistance | <table border="1"> <thead> <tr> <th>Tolerance</th> <th>ppm/°C</th> <th>Type</th> </tr> </thead> <tbody> <tr> <td rowspan="2">F</td> <td>100</td> <td>P</td> </tr> <tr> <td>200</td> <td>L</td> </tr> <tr> <td>G</td> <td>Table 9</td> <td>G, P, L</td> </tr> <tr> <td>J</td> <td>Table 9</td> <td>G, L</td> </tr> <tr> <td>K</td> <td>Table 9</td> <td>G, L</td> </tr> <tr> <td>L, M</td> <td>Table 9</td> <td>G, L, T</td> </tr> </tbody> </table> <p><Table 9></p> <table border="1"> <thead> <tr> <th>Range(Ω)</th> <th>ppm/°C</th> </tr> </thead> <tbody> <tr> <td>0.1 ≤ R < 1</td> <td>500(L-Type)</td> </tr> <tr> <td>1 ≤ R < 10</td> <td>+300, -200</td> </tr> <tr> <td>10 ≤ R < 1M</td> <td>±200</td> </tr> <tr> <td>1M ≤ R < 10M</td> <td>±300</td> </tr> </tbody> </table> | Tolerance | ppm/°C | Type | F | 100 | P | 200 | L | G | Table 9 | G, P, L | J | Table 9 | G, L | K | Table 9 | G, L | L, M | Table 9 | G, L, T | Range(Ω) | ppm/°C | 0.1 ≤ R < 1 | 500(L-Type) | 1 ≤ R < 10 | +300, -200 | 10 ≤ R < 1M | ±200 | 1M ≤ R < 10M | ±300 | - | <ul style="list-style-type: none"> Standard : JIS C 5202 (5.2) Temp. : 20°C → -55°C → 20°C → 125°C → 20°C Test board : <Fig 11> Calculation : $TCR(ppm/°C) = \frac{R - R_0}{R_0} \times \frac{1}{T - T_0} \times 10^6$ T₀ : 20 ± 2°C R₀ : Resistance at T₀ (Ω) T : Test temperature (-55, 125°C) R : Resistance at T (Ω) |
| Tolerance | ppm/°C | Type | | | | | | | | | | | | | | | | | | | | | | | | | | | | | | | |
| F | 100 | P | | | | | | | | | | | | | | | | | | | | | | | | | | | | | | | |
| | 200 | L | | | | | | | | | | | | | | | | | | | | | | | | | | | | | | | |
| G | Table 9 | G, P, L | | | | | | | | | | | | | | | | | | | | | | | | | | | | | | | |
| J | Table 9 | G, L | | | | | | | | | | | | | | | | | | | | | | | | | | | | | | | |
| K | Table 9 | G, L | | | | | | | | | | | | | | | | | | | | | | | | | | | | | | | |
| L, M | Table 9 | G, L, T | | | | | | | | | | | | | | | | | | | | | | | | | | | | | | | |
| Range(Ω) | ppm/°C | | | | | | | | | | | | | | | | | | | | | | | | | | | | | | | | |
| 0.1 ≤ R < 1 | 500(L-Type) | | | | | | | | | | | | | | | | | | | | | | | | | | | | | | | | |
| 1 ≤ R < 10 | +300, -200 | | | | | | | | | | | | | | | | | | | | | | | | | | | | | | | | |
| 10 ≤ R < 1M | ±200 | | | | | | | | | | | | | | | | | | | | | | | | | | | | | | | | |
| 1M ≤ R < 10M | ±300 | | | | | | | | | | | | | | | | | | | | | | | | | | | | | | | | |
| Short time overload (STOL) | <ol style="list-style-type: none"> No mechanical damage ΔR should be within ±(1%+0.1Ω) | 50mΩ Maximum | <ul style="list-style-type: none"> Standard : JIS C 5202. (5.5) Test voltage : 2.5 times of rated voltage Max. surge current at the Jumper. Applying time : 5 seconds Test board : <Fig 11> | | | | | | | | | | | | | | | | | | | | | | | | | | | | | | |
| Intermittent overload (IOL) | <ol style="list-style-type: none"> No mechanical damage ΔR should be within ±(3%+0.1Ω) | 50mΩ Maximum | <ul style="list-style-type: none"> Standard : JIS C 5202. (5.8) Test voltage : 2.5 times of rated voltage Max. surge current at the Jumper. Test method : 1 sec ON, 25 sec OFF 10,000⁺⁴⁰⁰cycles Test board : <Fig 11> | | | | | | | | | | | | | | | | | | | | | | | | | | | | | | |

Chip Resistor

| item | Permissible deviation | | Test method |
|-----------------------|----------------------------------------------------------------------------------------------------------|--------------|---------------------------------------------------------------------------------------------------------------------------------------------------------------------------------------------------------------------------------------------------------------------|
| | Resistor | Jumper | |
| Withstanding voltage | <ul style="list-style-type: none"> No mechanical damage, short circuit, or disconnection. | Same as left | <ul style="list-style-type: none"> Standard : JIS C 5202. (5.7) Test voltage : 1005 1608 AC 100V, others AC 500V Applying time : 60 +10/-0 seconds Test board : <Fig 13> |
| Insulation resistance | <ul style="list-style-type: none"> Should have more than 1,000MΩ | Same as left | <ul style="list-style-type: none"> Standard : JIS C 5202. (5.6) Test voltage : 1005 1608 DC 100V, others DC 500V Applying time : 60 seconds Test pressure : 1.0\pm0.2 N Test board : <Fig 13> |
| Noise | <ul style="list-style-type: none"> Noise standard <Table 10> | | <ul style="list-style-type: none"> Standard : JIS C 5202. (5.9) JIS appendix1 "Noise measure in resistor" Measure equipment : QUAN-TECH NOISE METER (MODEL 315C) |
| | Range (Ω) | dB Max. | |
| | 0.1 \leq R < 1 | -10(L-Type) | |
| | 1 \leq R < 100 | -10 | |
| | 100 \leq R < 1K | 0 | |
| 1K \leq R < 100K | 15 | | |
| 100K \leq R < 1M | 20 | | |
| 1M \leq R < 10M | 30 | | |

● MECHANICAL CHARACTERISTIC

The mechanical characteristic test should satisfy the test method, procedure, and standard. If there is no special comment, Each test performs in standard state. (temperature 20 $^{\circ}$ C, humidity 65%RH, pressure 1023mbar)

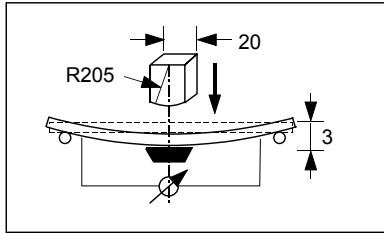
| item | Permissible deviation | | Test method |
|------------------|-----------------------------------------------------------------------------------------------------------------------------------------------------------|--------------|----------------------------------------------------------------------------------------------------------------------------------------------------------------------------------------------------------------------------------------------------------------------------------------------------------------------------------------------|
| | Resistor | Jumper | |
| Solderability | <ul style="list-style-type: none"> New solder coated more than 95% of termination | Same as left | <ul style="list-style-type: none"> Standard : JIS C 5202. (6.5) Test temperature : 235 \pm 5$^{\circ}$C Test time : 2 \pm 0.5 sec (dipping both side) |
| Bending strength | <ol style="list-style-type: none"> No mechanical damage ΔR should be within $\pm(0.5\%+0.05\Omega)$ | Same as left | <ul style="list-style-type: none"> Standard : JIS C 5202. (6.1) Test board : <Fig 12> Test speed : 100mm/min Test procedure : press until 3mm, then keep 5 seconds <Fig 14> <p><Fig 14></p>  |

Chip Resistor

| item | Permissible deviation | | Test method |
|-----------------------------|---------------------------------------------------------------------------------------------------------------------------------------------------------|-------------------------|------------------------------------------------------------------------------------------------------------------------------------------------------------------------------------------------------------------------------------------------------------------|
| | Resistor | Jumper | |
| Termination strength | <ul style="list-style-type: none"> No mechanical damage, or sign of disconnection | Same as left | <ul style="list-style-type: none"> Standard : JIS C 5202 (6.1) Test time : applying pressure for 10 seconds Test tension : 5 N (500g · f) 1005, 1608 - 3 N (300g · f) |
| Withstanding soldering heat | <ol style="list-style-type: none"> No mechanical damage ΔR should be within $\pm(1\%+0.05\Omega)$ | 50m Ω Maximum | <ul style="list-style-type: none"> Standard : JIS C 5202 (6.4) Temperature : $260 \pm 5^\circ\text{C}$ Test time : 10 ± 1second (both side dipping) Test procedure : measures after 24 hours |
| Vibration | <ol style="list-style-type: none"> No mechanical damage ΔR should be within $\pm(1\%+0.05\Omega)$ | 50m Ω Maximum | <ul style="list-style-type: none"> Standard : JIS C 5202 (6.3) Test amplitude : 1.5mm Test procedure : frequency 10Hz - 55Hz - 10Hz each 2 hours in x, y, z direction. |

● ENVIRONMENTAL CHARACTERISTIC

The Environmental characteristic test should satisfy the test method, procedure, and standard. If there is no special comment, Each test performs in standard state.
(temperature 20°C, humidity 65%RH, pressure 1023mbar)

| item | Permissible deviation | | Test method | | | | | | | | | | | | | | | |
|--------------------------|------------------------------------------------------------------------------------------------------------------------------------------------------------------------------------------------------------------------------------------------------------------------------------------------------------------------------------------------------------------------------------------------------------------------------------------------------------------------------------------------------------------------------------------------------------------------------------------------------------------------------------------------|-------------------------|----------------------------------------------------------------------------------------------------------------------------------------------------------------------------------------------------------------------------------------------------------------------------------------------------------------------------------------------------------------------------------------------------------------------------------------------------------------------------------------------------------------------|------------------|--------------------|-----------------|-----------|------------------|----------------------|-------------------|-----------|--------------------------|-------------------------------------------------------------------------------------------------------------------------------------------------------------------------------------------------------------------------------------------------------------------------------------------------------------------------------|-----------|----|----|----|----|
| | Resistor | Jumper | | | | | | | | | | | | | | | | |
| Temperature cycle | <ol style="list-style-type: none"> No mechanical damage ΔR should be within $\pm(1\%+0.1\Omega)$ | 50m Ω Maximum | <ul style="list-style-type: none"> Standard : JIS C 5202 (7.4) Test procedure : <Table 11> Measure : after 5 cycles of procedure Test board : <Fig 11> <table border="1"> <thead> <tr> <th>item</th> <th>1</th> <th>2</th> <th>3</th> <th>4</th> </tr> </thead> <tbody> <tr> <td>temp(°C)</td> <td>-55±2</td> <td>5~35</td> <td>125±2</td> <td>5~35</td> </tr> <tr> <td>time(min)</td> <td>30</td> <td>15</td> <td>30</td> <td>15</td> </tr> </tbody> </table> | item | 1 | 2 | 3 | 4 | temp(°C) | -55±2 | 5~35 | 125±2 | 5~35 | time(min) | 30 | 15 | 30 | 15 |
| item | 1 | 2 | 3 | 4 | | | | | | | | | | | | | | |
| temp(°C) | -55±2 | 5~35 | 125±2 | 5~35 | | | | | | | | | | | | | | |
| time(min) | 30 | 15 | 30 | 15 | | | | | | | | | | | | | | |
| Moisture resistance life | <ol style="list-style-type: none"> No mechanical damage ΔR should be within <Table 12> <table border="1"> <thead> <tr> <th>Range(Ω)</th> <th>ΔR MAX</th> </tr> </thead> <tbody> <tr> <td>$0.1 \leq R < 1$</td> <td>$\pm 5\%$(L-Type)</td> </tr> <tr> <td>$1 \leq R < 10$</td> <td>$\pm 5\%$</td> </tr> <tr> <td>$10 \leq R < 1M$</td> <td>$\pm(3\%+0.1\Omega)$</td> </tr> <tr> <td>$1M \leq R < 10M$</td> <td>$\pm 5\%$</td> </tr> </tbody> </table> | Range(Ω) | ΔR MAX | $0.1 \leq R < 1$ | $\pm 5\%$ (L-Type) | $1 \leq R < 10$ | $\pm 5\%$ | $10 \leq R < 1M$ | $\pm(3\%+0.1\Omega)$ | $1M \leq R < 10M$ | $\pm 5\%$ | 100m Ω Maximum | <ul style="list-style-type: none"> Standard : JIS C 5202 (7.9) Test condition : temp $40 \pm 3^\circ\text{C}$, humid 90 ~ 95%RH Test voltage : rated voltage Test time : repeat 90min ON, 30min OFF during 1000⁺⁴⁸ hours Test board : <Fig 11> | | | | | |
| Range(Ω) | ΔR MAX | | | | | | | | | | | | | | | | | |
| $0.1 \leq R < 1$ | $\pm 5\%$ (L-Type) | | | | | | | | | | | | | | | | | |
| $1 \leq R < 10$ | $\pm 5\%$ | | | | | | | | | | | | | | | | | |
| $10 \leq R < 1M$ | $\pm(3\%+0.1\Omega)$ | | | | | | | | | | | | | | | | | |
| $1M \leq R < 10M$ | $\pm 5\%$ | | | | | | | | | | | | | | | | | |

Chip Resistor

| item | Permissible deviation | | Test method |
|---------------------------|--------------------------------------------------------------------------------|-------------------------|--------------------------------------------------------------------------------------------------------------------------------------------------------------------------------------------------------------------------------------------------------------------------------------------------------------------------------------------------|
| | Resistor | Jumper | |
| Low temperature exposure | 1. No mechanical damage 2. ΔR should be within $\pm(3\%+0.1\Omega)$ | 50m Ω Maximum | <ul style="list-style-type: none"> Standard : JIS C 5202 (7.1) Test temperature : $-55 \pm 2^\circ\text{C}$ Test time : 1000⁺⁴⁸ hours (without load) Measure : after 1 hour Test board : <Fig 11> |
| High temperature exposure | 1. No mechanical damage 2. ΔR should be within $\pm(3\%+0.1\Omega)$ | 50m Ω Maximum | <ul style="list-style-type: none"> Standard : JIS C 5202 (7.2) Test temperature : 1608,2012,3216 : $155 \pm 2^\circ\text{C}$, others : $125 \pm 2^\circ\text{C}$ Test time : 1000⁺⁴⁸ hours (without load) Measure : after 1 hour Test board : <Fig 11> |
| Load life | 1. No mechanical damage 2. ΔR should be within <Table 13> | 100m Ω | <ul style="list-style-type: none"> Standard : JIS C 5202 (7.10) Test temperature : $70 \pm 2^\circ\text{C}$ Test voltage : rated voltage Test time : repeat 90min ON, 30min OFF during 1000⁺⁴⁸ hours Test board : <Fig 11>. |
| | <Table 13> | Maximum | |
| | Range(Ω) | ΔR MAX | |
| | 0.1 \leq R < 1 | $\pm 5\%$ (L-Type) | |
| | 1 \leq R < 10 | $\pm 5\%$ | |
| 10 \leq R < 1M | $\pm(3\%+0.1\Omega)$ | | |
| 1M \leq R < 10M | $\pm 5\%$ | | |

● TEST BOARD AND SPECIFICATION

▶ Soldering

▷ The resistor should be fixed on PCB(printed circuit board) for testing.

- Soldering specification : JIS C 5202 (6.2)

* Soldering method : Flow type(Dipping type), Reflow type

* Solder : H63A (JIS Z 3282)

* FLUX : ROSIN 25WT% (JIS K 5902), IPA 75WT% (JIS K 5901)

- Flow soldering condition

* FLUX dipping time : 5~10 sec

* Pre-treatment : None

* Soldering temp. : $235^\circ\text{C} \pm 5^\circ\text{C}$

* Soldering time : 5 ± 0.5 sec

* Temp. profile : <Fig 15>

- Reflow soldering condition

* Peak temp. : $230^\circ\text{C} \pm 5^\circ\text{C}$

* Duration over 220°C : 15 ± 5 sec

* Solder Cream : Sn-Pb (63-37)

* Temp. Profile : <Fig 16>

Chip Resistor

▶ Test board

▷ Test board

<Table 14>

| item | | Dimension (mm) | | | |
|-----------|-------|----------------|-----|------|-----|
| Dimension | Power | a | b | c | f |
| 0603 | 1/20W | 0.3 | 1.4 | 0.3 | 5.2 |
| 1005 | 1/16W | 0.6 | 1.9 | 0.7 | 4.9 |
| 1608 | 1/10W | 1.0 | 3.0 | 1.2 | 4.5 |
| 2012 | 1/8W | 1.2 | 4.0 | 1.65 | 4.3 |
| 3216 | 1/4W | 2.2 | 5.0 | 2.0 | 3.3 |
| 3225 | 1/4W | 2.2 | 5.0 | 2.9 | 3.3 |
| 5025 | 1/2W | 3.6 | 7.0 | 3.0 | 3.0 |
| 6432 | 1W | 5.2 | 8.0 | 3.5 | 2.5 |

<Fig 11>

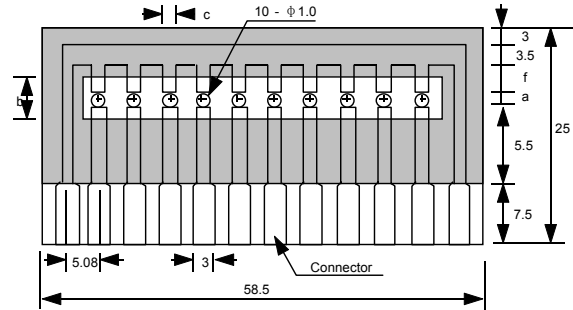

□ : COPPER PATTERN
 ■ : SOLDER - RESISTOR

<Table 14>, <Fig 11> are dimensions of test board.

* Board material : epoxy JIS C 6484

* pattern material : pure copper 99.5% or above JIS C 6484

▷ Bending Test Board

<Table 15>

| item | | Dimension (mm) | | | |
|-----------|-------|----------------|-----|------|-----|
| Dimension | Power | a | b | c | f |
| 0603 | 1/20W | 0.3 | 1.4 | 0.3 | 5.2 |
| 1005 | 1/16W | 0.6 | 1.9 | 0.7 | 4.9 |
| 1608 | 1/10W | 1.0 | 3.0 | 1.2 | 4.5 |
| 2012 | 1/8W | 1.2 | 4.0 | 1.65 | 4.3 |
| 3216 | 1/4W | 2.2 | 5.0 | 2.0 | 3.3 |
| 3225 | 1/4W | 2.2 | 5.0 | 2.9 | 3.3 |
| 5025 | 1/2W | 3.6 | 7.0 | 3.0 | 3.0 |
| 6432 | 1W | 5.2 | 8.0 | 3.5 | 2.5 |

<Fig 12>

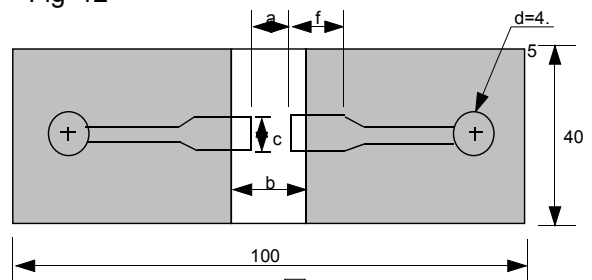

□ : COPPER PATTERN
 ■ : SOLDER - RESISTOR

<Table 15>, <Fig 12> are dimensions of bending test board.

* Board material : epoxy JIS C 6484

* pattern material : pure copper 99.5% or above JIS C 6484

▶ Sketch of Withstanding voltage and Insulation resistance

<Fig 13>

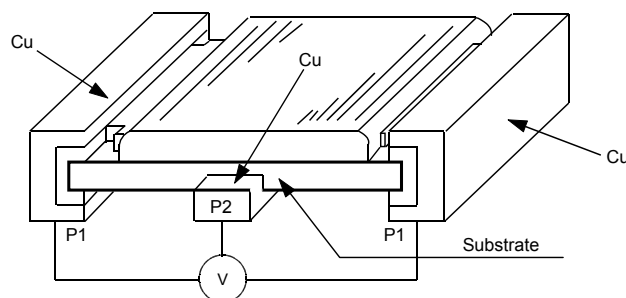

Chip Resistor

■ CHARACTERISTIC GRAPH

● RESISTANCE RANGE

The Resistance Range that we produce depends on the Dimension and the Resistance Tolerance of the resistor. <Table 16>

<Table 16>

| Dimension Tolerance | 0603 (0201) | 1005 (0402) | 1608 (0603) | 2012 (0805) | 3216 (1206) | 3225 (1210) | 5025 (2010) | 6432 (2512) | Type |
|------------------------|----------------|----------------|----------------|----------------|----------------|----------------|----------------|----------------|------|
| F | | 10Ω ~ 1MΩ | 10Ω ~ 1MΩ | 10Ω ~ 1MΩ | 10Ω ~ 1MΩ | 10Ω ~ 1MΩ | 10Ω ~ 1MΩ | 10Ω ~ 1MΩ | P |
| | | | | 0.1Ω ~ 1MΩ | 0.1Ω ~ 1MΩ | 0.1Ω ~ 1MΩ | 0.1Ω ~ 1MΩ | 0.1Ω ~ 1MΩ | L |
| G | 1Ω ~ 10MΩ | 1Ω ~ 10MΩ | 1Ω ~ 10MΩ | 1Ω ~ 10MΩ | 1Ω ~ 10MΩ | 1Ω ~ 10MΩ | 1Ω ~ 10MΩ | 1Ω ~ 10MΩ | G |
| | | 10Ω ~ 1MΩ | 10Ω ~ 1MΩ | 10Ω ~ 1MΩ | 10Ω ~ 1MΩ | 10Ω ~ 1MΩ | 10Ω ~ 1MΩ | 10Ω ~ 1MΩ | P |
| | | | | 0.1Ω ~ 1MΩ | 0.1Ω ~ 1MΩ | 0.1Ω ~ 1MΩ | 0.1Ω ~ 1MΩ | 0.1Ω ~ 1MΩ | L |
| J | 1Ω ~ 10MΩ | 1Ω ~ 10MΩ | 1Ω ~ 10MΩ | 1Ω ~ 10MΩ | 1Ω ~ 10MΩ | 1Ω ~ 10MΩ | 1Ω ~ 10MΩ | 1Ω ~ 10MΩ | G |
| | | | | 0.1Ω ~ 1MΩ | 0.1Ω ~ 1MΩ | 0.1Ω ~ 1MΩ | 0.1Ω ~ 1MΩ | 0.1Ω ~ 1MΩ | L |
| K | 1Ω ~ 10MΩ | 1Ω ~ 10MΩ | 1Ω ~ 10MΩ | 1Ω ~ 10MΩ | 1Ω ~ 10MΩ | 1Ω ~ 10MΩ | 1Ω ~ 10MΩ | 1Ω ~ 10MΩ | G |
| | | | | 0.1Ω ~ 1MΩ | 0.1Ω ~ 1MΩ | 0.1Ω ~ 1MΩ | 0.1Ω ~ 1MΩ | 0.1Ω ~ 1MΩ | L |
| | | | 1Ω ~ 10MΩ | 1Ω ~ 10MΩ | 1Ω ~ 10MΩ | 1Ω ~ 10MΩ | 1Ω ~ 10MΩ | 1Ω ~ 10MΩ | T |
| L, M | | | 1Ω ~ 10MΩ | 1Ω ~ 10MΩ | 1Ω ~ 10MΩ | 1Ω ~ 10MΩ | 1Ω ~ 10MΩ | 1Ω ~ 10MΩ | T |

Type Representation : G(General), P(Precision), L(Low ohms), T(Trimmable)

Chip Resistor

● RATED POWER

The Rated Power is classified by the dimension of the resistor. <Table 17>

<Table 17>

| Dimension item | 0603 (0201) | 1005 (0402) | 1608 (0603) | 2012 (0805) | 3216 (1206) | 3225 (1210) | 5025 (2010) | 6432 (2512) |
|-----------------------|--------------------|---------------------|---------------------|--------------------|-------------------|-------------------|-----------------|----------------|
| Rated Power | 1/20 W (0.05 W) | 1/16 W (0.063 W) | 1/10 W (0.100 W) | 1/8 W (0.125 W) | 1/4 W (0.25 W) | 1/4 W (0.25 W) | 1/2 W (0.5W) | 1.0 W |
| Working Volt.(Max.) | 25 V | 50 V | 50 V | 150 V | 200 V | 200 V | 200 V | 200 V |
| STOL, IOL Volt.(Max.) | 50 V | 100 V | 100 V | 300 V | 400 V | 400 V | 400 V | 400 V |

※ The rated power is specified as continuous full loading power at the ambient temperature of $70 \pm 2^\circ\text{C}$. In case of the temperature exceeding $70 \pm 2^\circ\text{C}$, the power should be derated in accordance to <Fig 17>.

<Fig 17>

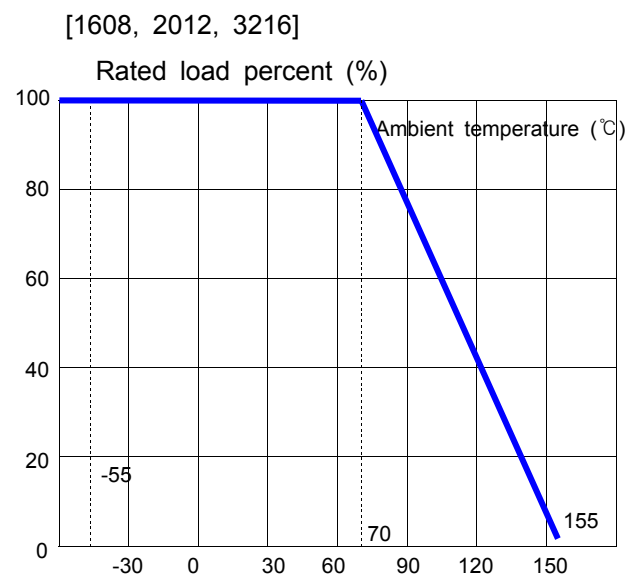
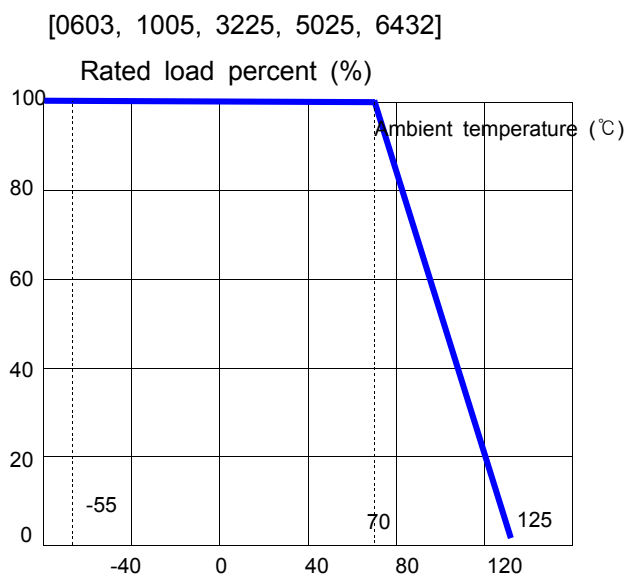

► Working Temperature

- $55^\circ\text{C} \sim +125^\circ\text{C}$: 0603, 1005, 3225, 5025, 6432
- $55^\circ\text{C} \sim +155^\circ\text{C}$: 1608, 2012, 3216

Chip Resistor

■ APPLICATION MANUAL

● Applications

Chip resistors are designed for general electronic devices such as home appliances, computer, mobile communications, digital circuit, etc.

If you require our products with high reliability-performing at more than 125C or below -55C- for medical equipments, aircraft, high speed machines, military usage, and items that can affect human life or if you need to use in specific conditions (corrosive gas atmosphere), please contact us beforehand.

▶ Normal Operation temperature ranges(°C) as follows.

- 1608, 2012, 3216(general, precision) : -55°C ~ + 155°C
- Others (rectangular, array, trimmable) : -55°C ~ + 125°C

- ▶ Although resistor body is coated, sharp excessive impact should be avoided to prevent damages and adverse effects on characteristics(resistor value, open circuited, T.C.R.).

● Storage

To maintain proper quality of chip components, the following precautions are required for storage environment, method and period.

▶ Storage Environment

- Chip components may be deformed, if the temperature of packaged components exceeds 40C.
- Do not store where the soldering properties can be deteriorated by harmful gas such as sulphurous gas, chlorine gas, etc.
- Bulk packed chip components should be used as soon as the seal is opened, thus preventing the solderability from deteriorating.
- The remaining unused chips should be put in the original bag and sealed again or store in a desiccator containing a desiccating agent.

▶ Storage Time Period

- Stored chip components should be used within 12 months after receiving the components. If 12 months or more have elapsed, please check the solderability before actually using.

● Mounting

Please give more attention not to press the chip owing to the nozzle's improper height when it is mounted on PCB.

(Excessive pressure may cause exterior damage, change in resistance, circuit open, etc.)

Chip Resistor

● Soldering

Our products have Ag electrodes protected by double layer.

▶ 1st Ni Coating

- This prevents Ag electrode from leaching and enhance the bonding with Sn-Pb.

▶ 2nd Sn-Pb Coating

- This is made of Sn 90% and Pb 10% with melting point 213°C to prevent it from melting when solder cream melts, and to enhance the bonding.
- Commercial solder creams are made of Sn 63% and Pb 37% with melting point 183°C.

● Cleaning

After Soldering Cleaning, soldering flux & Ionic cleaning liquid should be avoided on product. If any possibility on product, please take a test before usage.

● Caution for chip resistor separation from PCB

Chip resistor installation on PCB is similar phenomenon on chocolate chip on top of cake.

PCB has enough flexibility on outer force but Chip resistor can be defected without any bending.

(By chip resistor use of Ceramic, solder, metal)

Therefore, when separate from Chip resistor on PCB, be ware of any crack of chip

● Others

▶ Manual work

- Whenever separate chip resistor from PCB, do not re-use the chip resistor for circuit safety. chip resistor can be electrical specification change by soldering Iron after separation. Re-use of separated chip resistor should be prohibited.

▶ Do not use more than rated voltage.(check the contents on the file)

Chip Resistor

NOTICE

Usage of the resistor

Flow Soldering

After sticking the resistor to PCB with paste, dip the PCB into solder bath. <Fig 15>

<Fig 15>

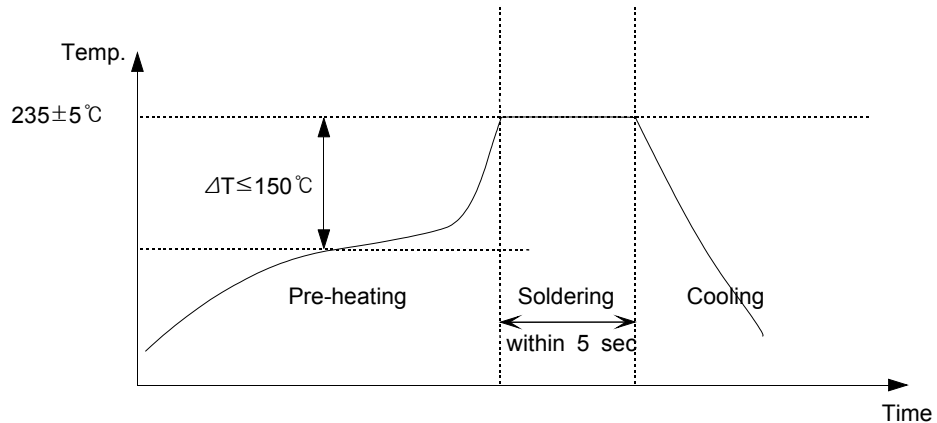

Reflow Soldering

After printing solder creams on PCB, place the resistor on the solder cream.

Then heat the PCB. <Fig 16>

<Fig 16>

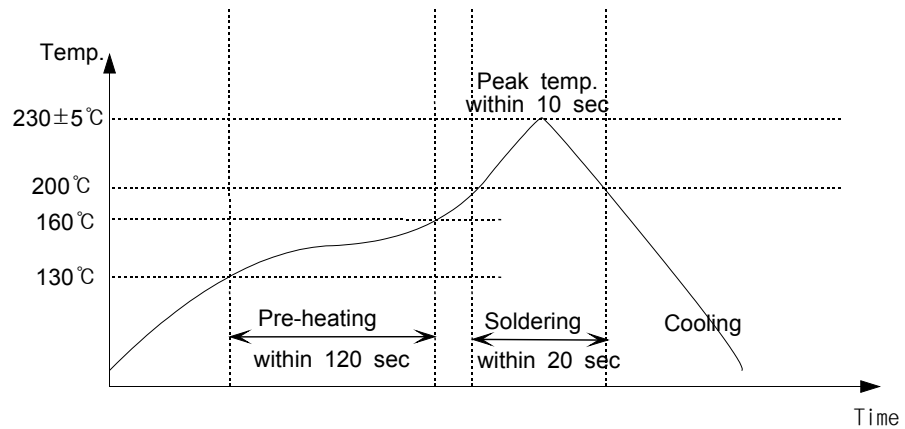

Caution

Storage condition

Please make sure that keep the storage conditions.

* Temperature : $5^\circ\text{C} \sim 35^\circ\text{C}$, * Humidity : 45%RH ~ 85%RH

Damage control

Please handle with care, to prevent damaging the resistor.

Specially, the excessive nozzles' height of SMD or the extreme touch with tweezers.

Leaching prevention

It is important to keep the soldering conditions for prevent Ag leaching in Flow soldering.