HN58V256A Series

HN58V257A Series

256k EEPROM (32-kword × 8-bit)
Ready/Busy and $\overline{\text{RES}}$ function (HN58V257A)

REJ03C0147-0500Z
(Previous ADE-203-357D (Z) Rev.4.0)
Rev. 5.00
Nov. 17. 2003

Description

Renesas Technology's HN58V256A and HN58V257A are electrically erasable and programmable ROMs organized as 32768-word × 8-bit. They have realized high speed, low power consumption and high reliability by employing advanced MNOS memory technology and CMOS process and circuitry technology. They also have a 64-byte page programming function to make their write operations faster.

Features

- Single 3 V supply: 2.7 to 5.5 V
- Access time: 120 ns max
- Power dissipation:
 - Active: 20 mW/MHz, (typ)
 - Standby: 110 μ W (max)
- On-chip latches: address, data, $\overline{\text{CE}}$, $\overline{\text{OE}}$, $\overline{\text{WE}}$
- Automatic byte write: 10 ms max
- Automatic page write (64 bytes): 10 ms max
- Ready/Busy (only the HN58V257A series)
- $\overline{\text{Data}}$ polling and Toggle bit
- Data protection circuit on power on/off
- Conforms to JEDEC byte-wide standard
- Reliable CMOS with MNOS cell technology
- 10^5 erase/write cycles (in page mode)
- 10 years data retention
- Software data protection
- Write protection by $\overline{\text{RES}}$ pin (only the HN58V257A series)
- Industrial versions (Temperature range: -20 to 85°C and -40 to 85°C) are also available.
- There are free also lead free products.

Ordering Information

Type No.	Access time	Package
HN58V256AFP-12	120 ns	400 mil 28-pin plastic SOP (FP-28D)
HN58V256AT-12	120 ns	28-pin plastic TSOP (TFP-28DB)
HN58V257AT-12	120 ns	32-pin plastic TSOP (TFP-32DA)
HN58V256AFP-12E	120 ns	400 mil 28-pin plastic SOP (FP-28DV) Lead Free
HN58V256AT-12E	120 ns	28-pin plastic TSOP (TFP-28DBV) Lead Free
HN58V257AT-12E	120 ns	32-pin plastic TSOP (TFP-32DAV) Lead Free

Pin Arrangement

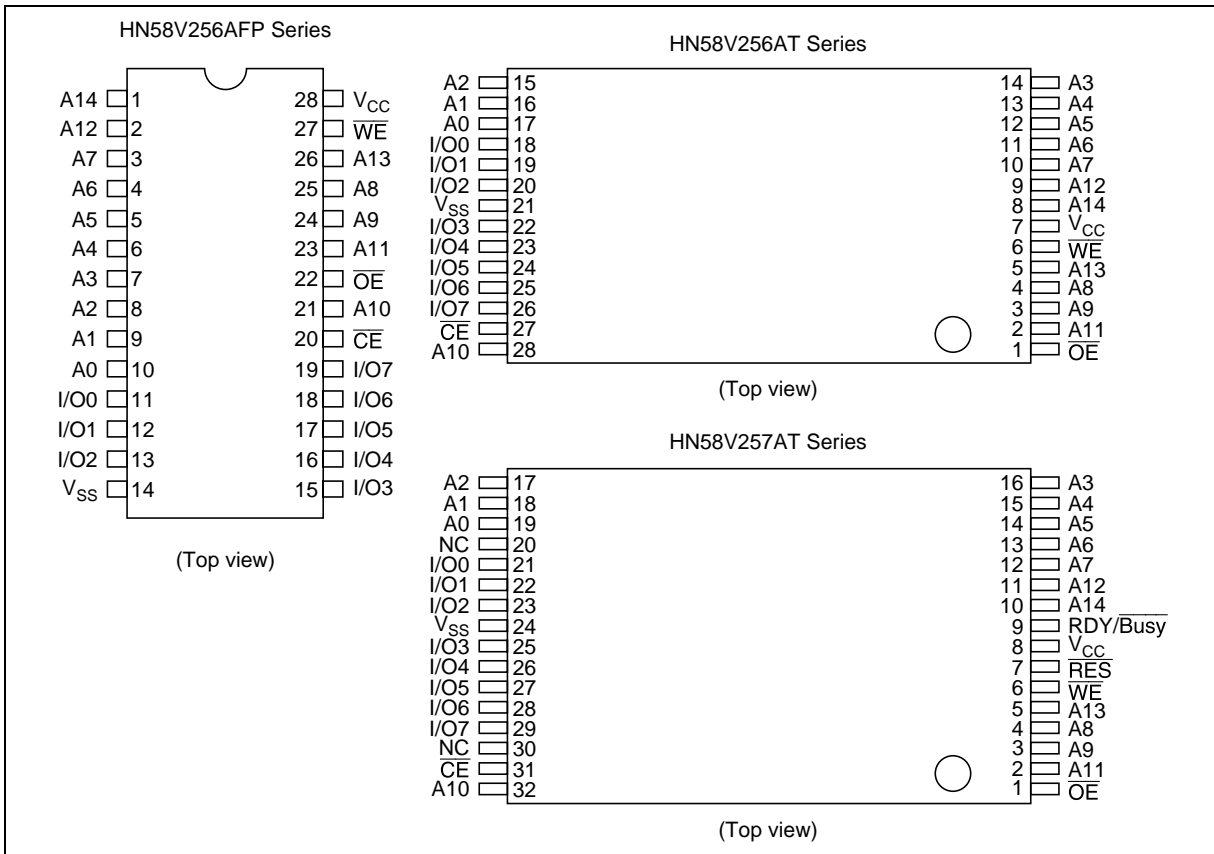

Pin Description

Pin name	Function
A0 to A14	Address input
I/O0 to I/O7	Data input/output
\overline{OE}	Output enable
\overline{CE}	Chip enable
\overline{WE}	Write enable
V_{CC}	Power supply
V_{SS}	Ground
$\overline{RDY/Busy}^{*1}$	Ready busy
\overline{RES}^{*1}	Reset
NC	No connection

Note: 1. This function is supported by only the HN58V257A series.

Block Diagram

Note: 1. This function is supported by only the HN58V257A series.

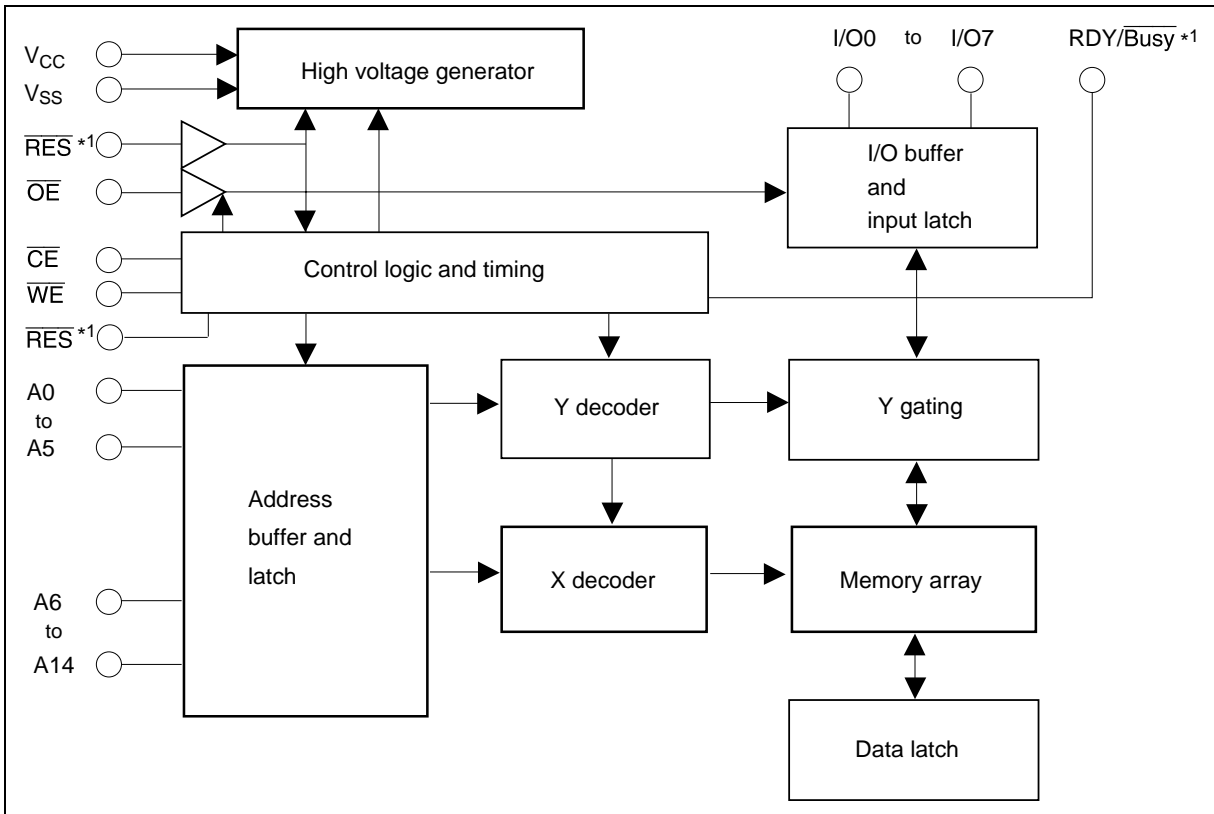

Operation Table

Operation	\overline{CE}	\overline{OE}	\overline{WE}	\overline{RES}^{*3}	$\overline{RDY/Busy}^{*3}$	I/O
Read	V_{IL}	V_{IL}	V_{IH}	V_H^{*1}	High-Z	Dout
Standby	V_{IH}	\times^{*2}	\times	\times	High-Z	High-Z
Write	V_{IL}	V_{IH}	V_{IL}	V_H	High-Z to V_{OL}	Din
Deselect	V_{IL}	V_{IH}	V_{IH}	V_H	High-Z	High-Z
Write inhibit	\times	\times	V_{IH}	\times	—	—
	\times	V_{IL}	\times	\times	—	—
Data polling	V_{IL}	V_{IL}	V_{IH}	V_H	V_{OL}	Data out (I/O7)
Program reset	\times	\times	\times	V_{IL}	High-Z	High-Z

- Notes: 1. Refer to the recommended DC operating condition.
 2. \times : Don't care
 3. This function is supported by only the HN58V267A series.

Absolute Maximum Ratings

Parameter	Symbol	Value	Unit
Supply voltage relative to V_{SS}	V_{CC}	-0.6 to +7.0	V
Input voltage relative to V_{SS}	V_{in}	-0.5 ^{*1} to +7.0 ^{*3}	V
Operating temperature range ^{*2}	T_{opr}	0 to +70	°C
Storage temperature range	T_{stg}	-55 to +125	°C

- Notes: 1. V_{in} min = -3.0 V for pulse width \leq 50 ns
 2. Including electrical characteristics and data retention
 3. Should not exceed $V_{CC} + 1.0$ V.

Recommended DC Operating Conditions

Parameter	Symbol	Min	Typ	Max	Unit
Supply voltage	V_{CC}	2.7	3.0	5.5	V
	V_{SS}	0	0	0	V
Input voltage	V_{IL}	-0.3 ^{*1}	—	0.6	V
	V_{IH}	1.9 ^{*2}	—	$V_{CC} + 0.3^{*3}$	V
	V_H^{*4}	$V_{CC} - 0.5$	—	$V_{CC} + 1.0$	V
Operating temperature	T_{opr}	0	—	+70	°C

- Notes: 1. V_{IL} min: -1.0 V for pulse width \leq 50 ns.
 2. V_{IH} min for $V_{CC} = 3.6$ to 5.5 V is 2.4 V.
 3. V_{IH} max: $V_{CC} + 1.0$ V for pulse width \leq 50 ns.
 4. This function is supported by only the HN58V257A series.

HN58V256A Series, HN58V257A Series

DC Characteristics (Ta = 0 to +70°C, V_{CC} = 2.7 to 5.5 V)

Parameter	Symbol	Min	Typ	Max	Unit	Test conditions
Input leakage current	I _{LI}	—	—	2* ¹	μA	V _{CC} = 5.5 V, Vin = 5.5 V
Output leakage current	I _{LO}	—	—	2	μA	V _{CC} = 5.5 V, Vout = 5.5/0.4 V
Standby V _{CC} current	I _{CC1}	—	—	20	μA	$\overline{CE} = V_{CC}$
	I _{CC2}	—	—	1	mA	$\overline{CE} = V_{IH}$
Operating V _{CC} current	I _{CC3}	—	—	8	mA	Iout = 0 mA, Duty = 100%, Cycle = 1 μs, V _{CC} = 3.6 V
				12	mA	Iout = 0 mA, Duty = 100%, Cycle = 1 ns, V _{CC} = 5.5 V
				12	mA	Iout = 0 mA, Duty = 100%, Cycle = 120 μs, V _{CC} = 3.6 V
				30	mA	Iout = 0 mA, Duty = 100%, Cycle = 120 ns, V _{CC} = 5.5 V
Output low voltage	V _{OL}	—	—	0.4	V	I _{OL} = 2.1 mA
Output high voltage	V _{OH}	V _{CC} × 0.8	—	—	V	I _{OH} = -400 μA

Note: 1. I_{LI} on RES = 100 μA max (only the HN58V257A series)

Capacitance (Ta = +25°C, f = 1 MHz)

Parameter	Symbol	Min	Typ	Max	Unit	Test conditions
Input capacitance* ¹	Cin	—	—	6	pF	Vin = 0 V
Output capacitance* ¹	Cout	—	—	12	pF	Vout = 0 V

Note: 1. This parameter is periodically sampled and not 100% tested.

AC Characteristics (Ta = 0 to +70°C, V_{CC} = 2.7 to 5.5 V)

Test Conditions

- Input pulse levels: 0.4 V to 2.4 V (V_{CC} ≤ 3.6V), 0.4V to 3.0 V (V_{CC} > 3.6 V), 0 V to V_{CC} ($\overline{\text{RES}}$ pin^{*2})
- Input rise and fall time: ≤ 5 ns
- Input timing reference levels: 0.8, 1.8 V
- Output load: 1TTL Gate +100 pF
- Output reference levels: 1.5 V, 1.5 V

Read Cycle

HN58V256A/HN58V257A					
-12					
Parameter	Symbol	Min	Max	Unit	Test conditions
Address to output delay	t _{ACC}	—	120	ns	$\overline{\text{CE}} = \overline{\text{OE}} = V_{\text{IL}}, \overline{\text{WE}} = V_{\text{IH}}$
$\overline{\text{CE}}$ to output delay	t _{CE}	—	120	ns	$\overline{\text{OE}} = V_{\text{IL}}, \overline{\text{WE}} = V_{\text{IH}}$
$\overline{\text{OE}}$ to output delay	t _{OE}	10	60	ns	$\overline{\text{CE}} = V_{\text{IL}}, \overline{\text{WE}} = V_{\text{IH}}$
Address to output hold	t _{OH}	0	—	ns	$\overline{\text{CE}} = \overline{\text{OE}} = V_{\text{IL}}, \overline{\text{WE}} = V_{\text{IH}}$
$\overline{\text{OE}}$ ($\overline{\text{CE}}$) high to output float ^{*1}	t _{DF}	0	40	ns	$\overline{\text{CE}} = V_{\text{IL}}, \overline{\text{WE}} = V_{\text{IH}}$
$\overline{\text{RES}}$ low to output float ^{*1,2}	t _{DFR}	0	350	ns	$\overline{\text{CE}} = \overline{\text{OE}} = V_{\text{IL}}, \overline{\text{WE}} = V_{\text{IH}}$
$\overline{\text{RES}}$ to output delay ^{*2}	t _{RR}	0	600	ns	$\overline{\text{CE}} = \overline{\text{OE}} = V_{\text{IL}}, \overline{\text{WE}} = V_{\text{IH}}$

HN58V256A Series, HN58V257A Series

Write Cycle

Parameter	Symbol	Min* ³	Typ	Max	Unit	Test conditions
Address setup time	t_{AS}	0	—	—	ns	
Address hold time	t_{AH}	50	—	—	ns	
\overline{CE} to write setup time (\overline{WE} controlled)	t_{CS}	0	—	—	ns	
\overline{CE} hold time (\overline{WE} controlled)	t_{CH}	0	—	—	ns	
\overline{WE} to write setup time (\overline{CE} controlled)	t_{WS}	0	—	—	ns	
\overline{WE} hold time (\overline{CE} controlled)	t_{WH}	0	—	—	ns	
\overline{OE} to write setup time	t_{OES}	0	—	—	ns	
\overline{OE} hold time	t_{OEH}	0	—	—	ns	
Data setup time	t_{DS}	70	—	—	ns	
Data hold time	t_{DH}	0	—	—	ns	
\overline{WE} pulse width (\overline{WE} controlled)	t_{WIP}	200	—	—	ns	
\overline{CE} pulse width (\overline{CE} controlled)	t_{CW}	200	—	—	ns	
Data latch time	t_{DL}	100	—	—	ns	
Byte load cycle	t_{BLC}	0.3	—	30	μ s	
Byte load window	t_{BL}	100	—	—	μ s	
Write cycle time	t_{WC}	—	—	10^{*4}	ms	
Time to device busy	t_{DB}	120	—	—	ns	
Write start time	t_{DW}	0^{*5}	—	—	ns	
Reset protect time* ²	t_{RP}	100	—	—	μ s	
Reset high time* ^{2,6}	t_{RES}	1	—	—	μ s	

Notes: 1. t_{DF} and t_{DFR} are defined as the time at which the outputs achieve the open circuit conditions and are no longer driven.

2. This function is supported by only the HN58V257A series.
3. Use this device in longer cycle than this value.
4. t_{WC} must be longer than this value unless polling techniques or $\overline{RDY}/\overline{Busy}$ (only the HN58V257A series) are used. This device automatically completes the internal write operation within this value.
5. Next read or write operation can be initiated after t_{DW} if polling techniques or $\overline{RDY}/\overline{Busy}$ (only the HN58V257A series) are used.
6. This parameter is sampled and not 100% tested.
7. A6 through A14 are page addresses and these addresses are latched at the first falling edge of \overline{WE} .
8. A6 through A14 are page addresses and these addresses are latched at the first falling edge of \overline{CE} .
9. See AC read characteristics.

Timing Waveforms

Read Timing Waveform

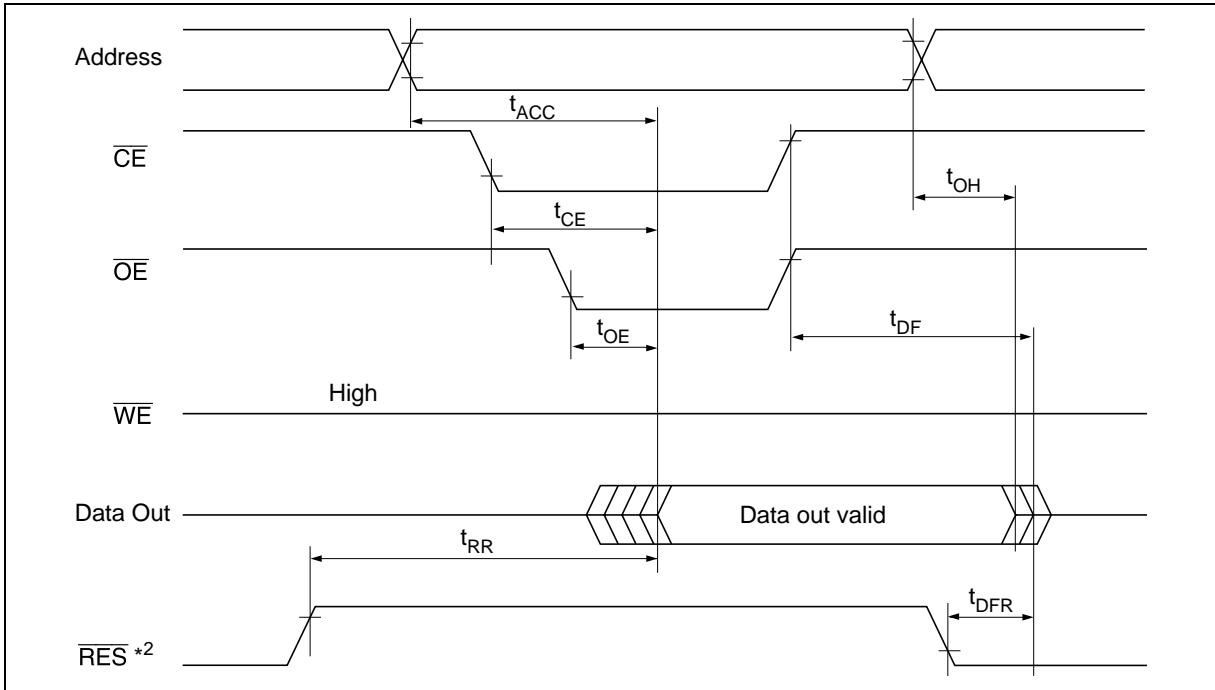

Byte Write Timing Waveform (1) (\overline{WE} Controlled)

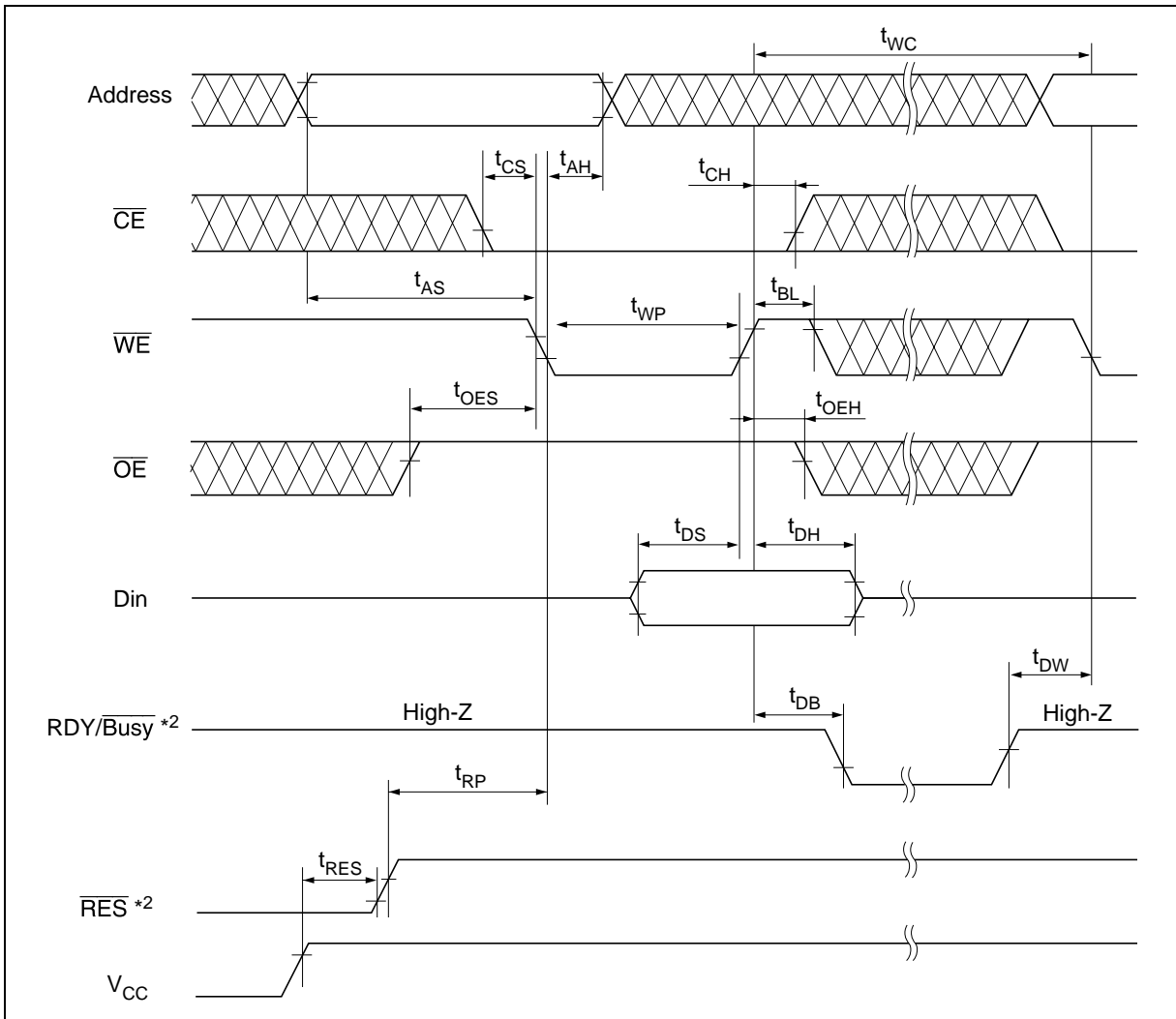

Byte Write Timing Waveform (2) ($\overline{\text{CE}}$ Controlled)

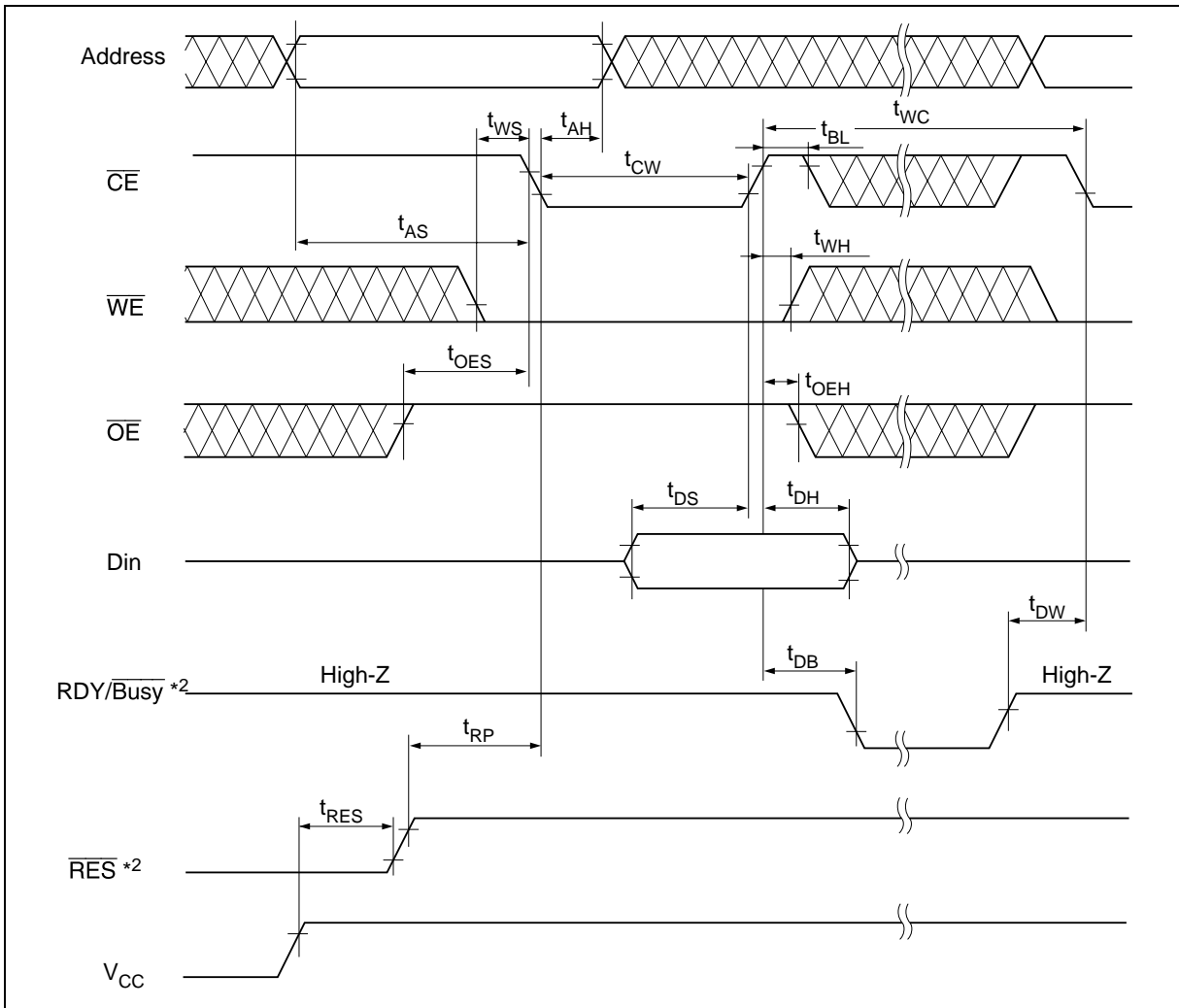

Page Write Timing Waveform (1) (\overline{WE} Controlled)

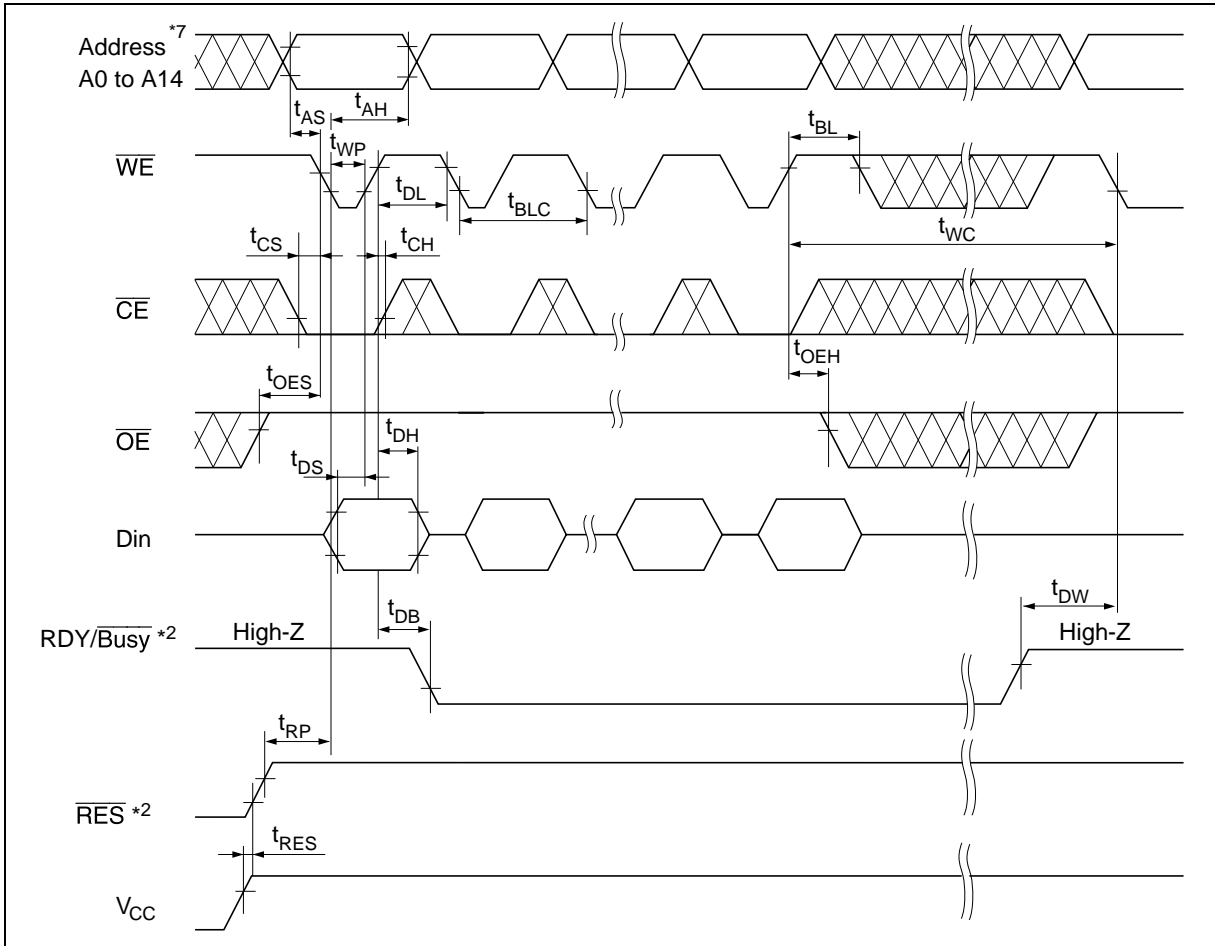

Page Write Timing Waveform (2) ($\overline{\text{CE}}$ Controlled)

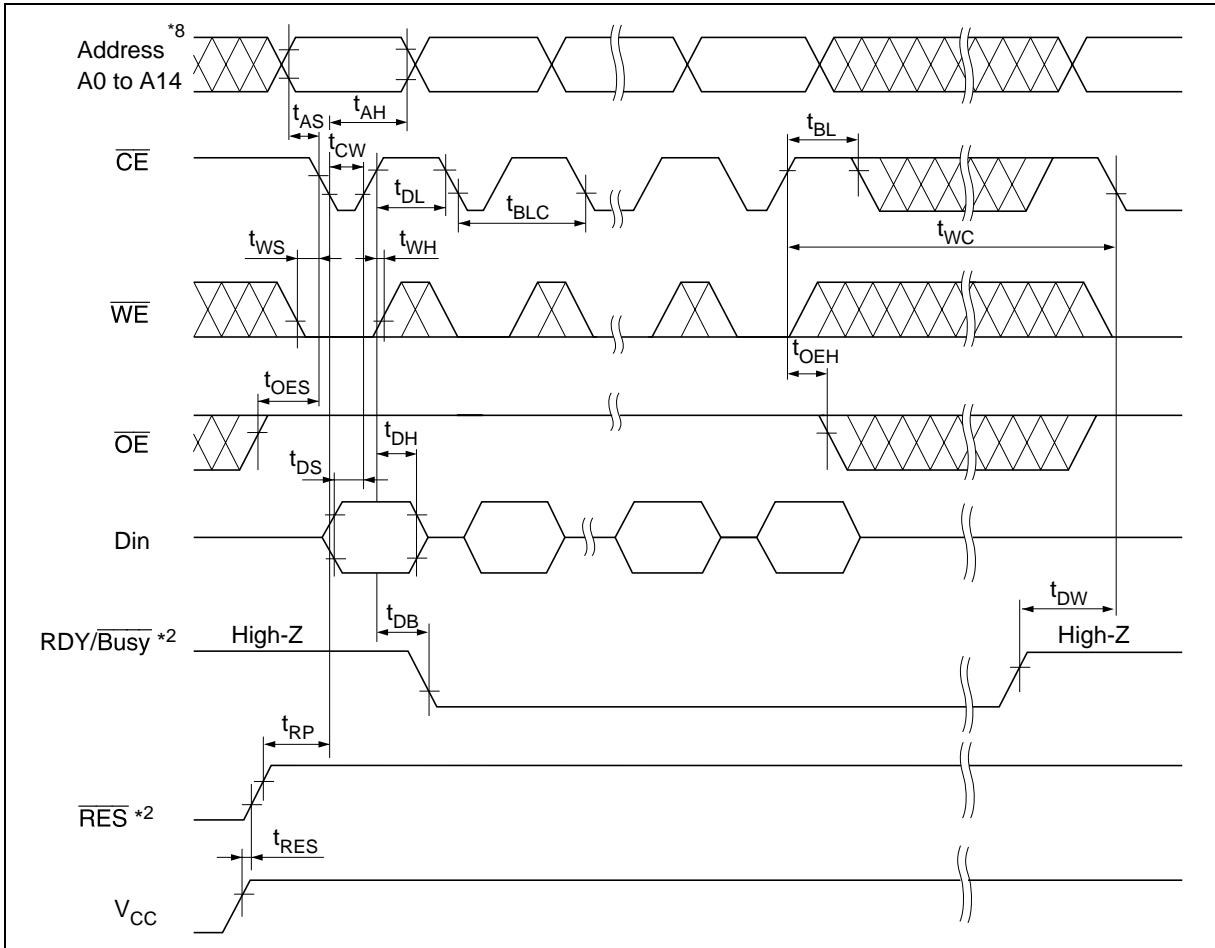

Toggle bit

This device provide another function to determine the internal programming cycle. If the EEPROM is set to read mode during the internal programming cycle, I/O6 will charge from “1” to “0” (toggling) for each read. When the internal programming cycle is finished, toggling of I/O6 will stop and the device can be accessible for next read or program.

Toggle bit Waveform

- Notes: 1. I/O6 beginning state is “1”.
 2. I/O6 ending state will vary.
 3. See AC read characteristics.
 4. Any address location can be used, but the address must be fixed.

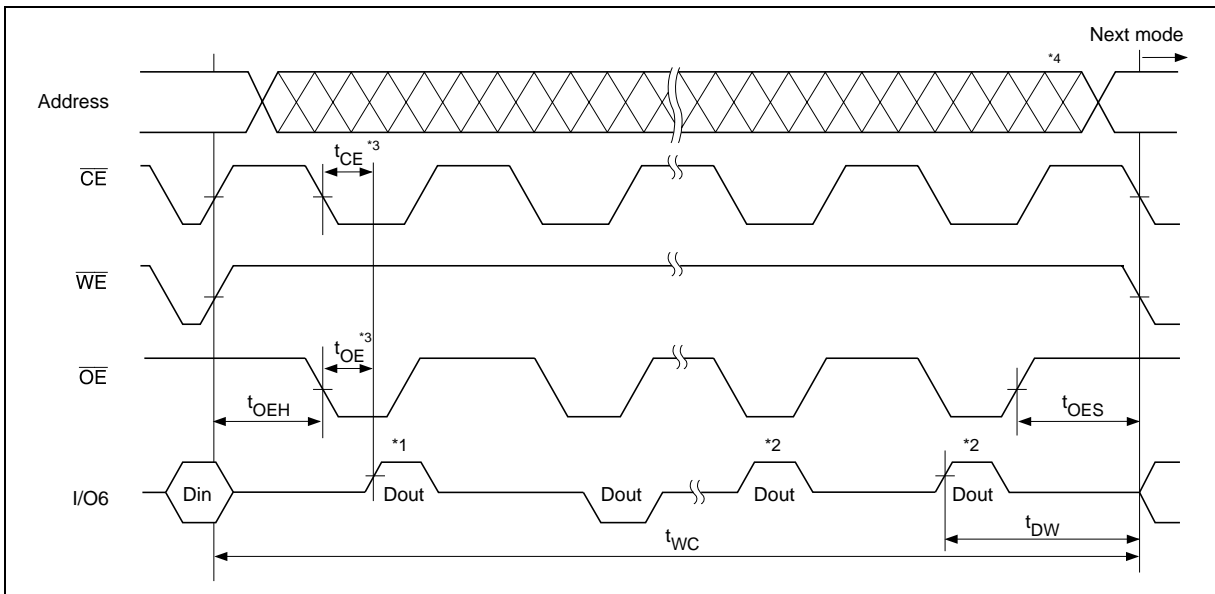

Software Data Protection Timing Waveform (1) (in protection mode)

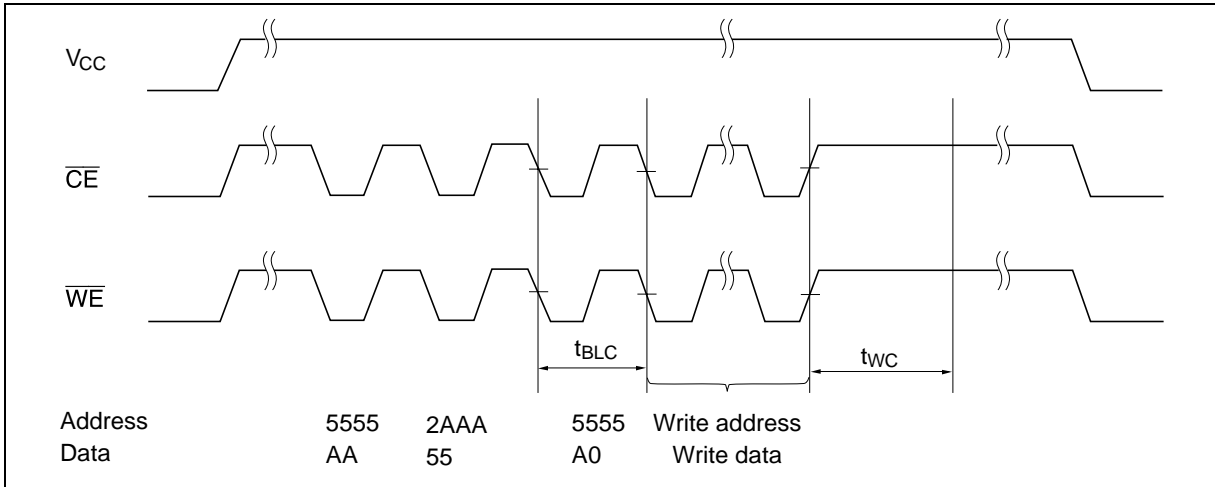

Software Data Protection Timing Waveform (2) (in non-protection mode)

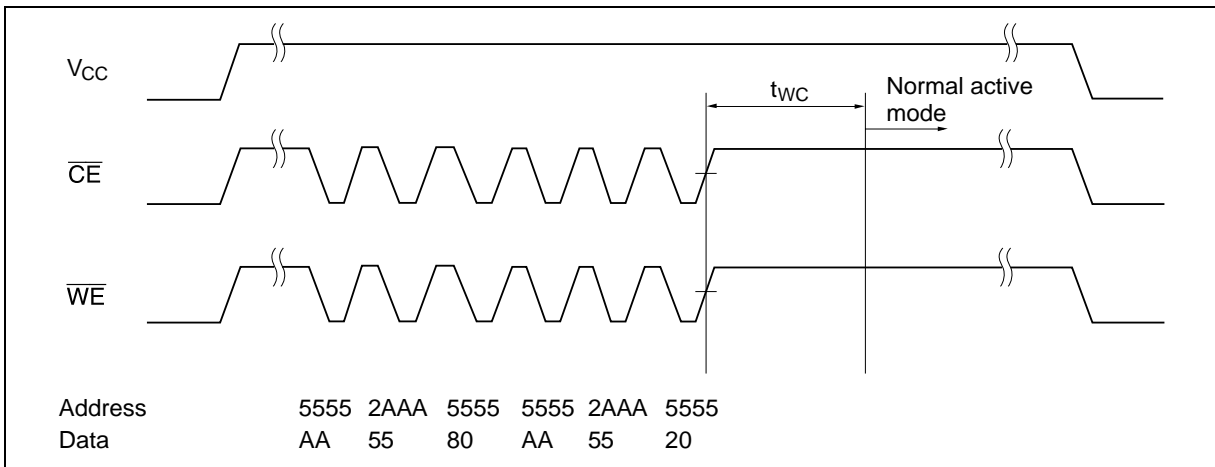

Functional Description

Automatic Page Write

Page-mode write feature allows 1 to 64 bytes of data to be written into the EEPROM in a single write cycle. Following the initial byte cycle, an additional 1 to 63 bytes can be written in the same manner. Each additional byte load cycle must be started within 30 μ s from the preceding falling edge of \overline{WE} or \overline{CE} . When \overline{CE} or \overline{WE} is high for 100 μ s after data input, the EEPROM enters write mode automatically and the input data are written into the EEPROM.

\overline{Data} Polling

\overline{Data} polling indicates the status that the EEPROM is in a write cycle or not. If EEPROM is set to read mode during a write cycle, an inversion of the last byte of data outputs from I/O7 to indicate that the EEPROM is performing a write operation.

$\overline{RDY/Busy}$ Signal (only the HN58V257A series)

$\overline{RDY/Busy}$ signal also allows the status of the EEPROM to be determined. The $\overline{RDY/Busy}$ signal has high impedance except in write cycle and is lowered to V_{OL} after the first write signal. At the end of a write cycle, the $\overline{RDY/Busy}$ signal changes state to high impedance.

\overline{RES} Signal (only the HN58V257A series)

When \overline{RES} is low, the EEPROM cannot be read or programmed. Therefore, data can be protected by keeping \overline{RES} low when V_{CC} is switched. \overline{RES} should be high during read and programming because it doesn't provide a latch function.

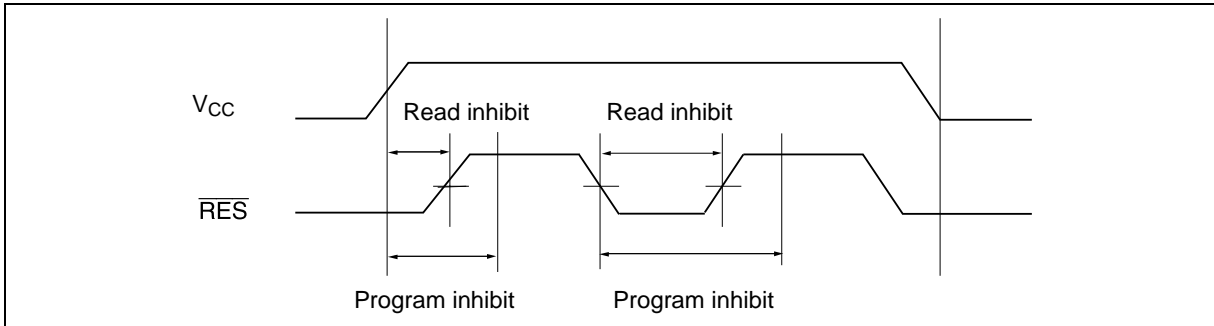

$\overline{\text{WE}}$, $\overline{\text{CE}}$ Pin Operation

During a write cycle, addresses are latched by the falling edge of $\overline{\text{WE}}$ or $\overline{\text{CE}}$, and data is latched by the rising edge of $\overline{\text{WE}}$ or $\overline{\text{CE}}$.

Write/Erase Endurance and Data Retention Time

The endurance is 10^5 cycles in case of the page programming and 10^4 cycles in case of the byte programming (1% cumulative failure rate). The data retention time is more than 10 years when a device is page-programmed less than 10^4 cycles.

Data Protection

To prevent this phenomenon, this device has a noise cancellation function that cuts noise if its width is 20 ns or less.

1. Data Protection against Noise on Control Pins ($\overline{\text{CE}}$, $\overline{\text{OE}}$, $\overline{\text{WE}}$) during Operation

During readout or standby, noise on the control pins may act as a trigger and turn the EEPROM to programming mode by mistake. Be careful not to allow noise of a width of more than 20 ns on the control pins.

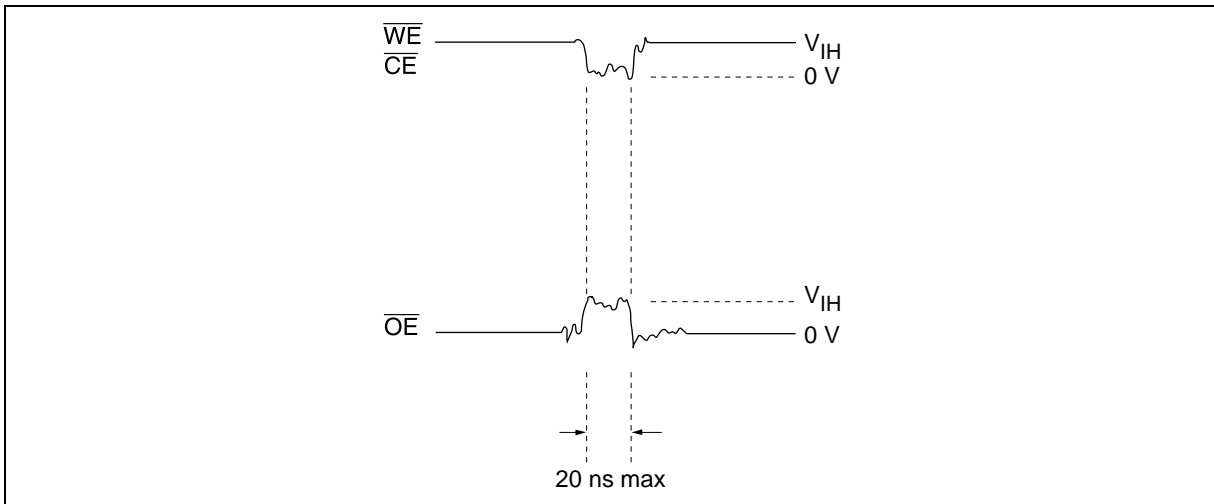

HN58V256A Series, HN58V257A Series

2. Data Protection at V_{CC} On/Off

When V_{CC} is turned on or off, noise on the control pins generated by external circuits (CPU, etc) may act as a trigger and turn the EEPROM to program mode by mistake. To prevent this unintentional programming, the EEPROM must be kept in an unprogrammable state while the CPU is in an unstable state.

Note: The EEPROM should be kept in unprogrammable state during V_{CC} on/off by using CPU RESET signal.

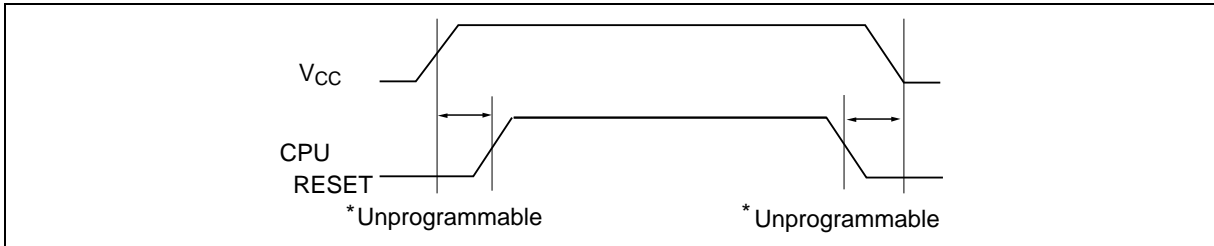

2.1 Protection by \overline{CE} , \overline{OE} , \overline{WE}

To realize the unprogrammable state, the input level of control pins must be held as shown in the table below.

\overline{CE}	V_{CC}	×	×
\overline{OE}	×	V_{SS}	×
\overline{WE}	×	×	V_{CC}

×: Don't care.

V_{CC} : Pull-up to V_{CC} level.

V_{SS} : Pull-down to V_{SS} level.

2.2 Protection by \overline{RES} (only the HN58V257A series)

The unprogrammable state can be realized by that the CPU's reset signal inputs directly to the EEPROM's RES pin. \overline{RES} should be kept V_{SS} level during V_{CC} on/off.

The EEPROM breaks off programming operation when \overline{RES} becomes low, programming operation doesn't finish correctly in case that \overline{RES} falls low during programming operation. \overline{RES} should be kept high for 10 ms after the last data input.

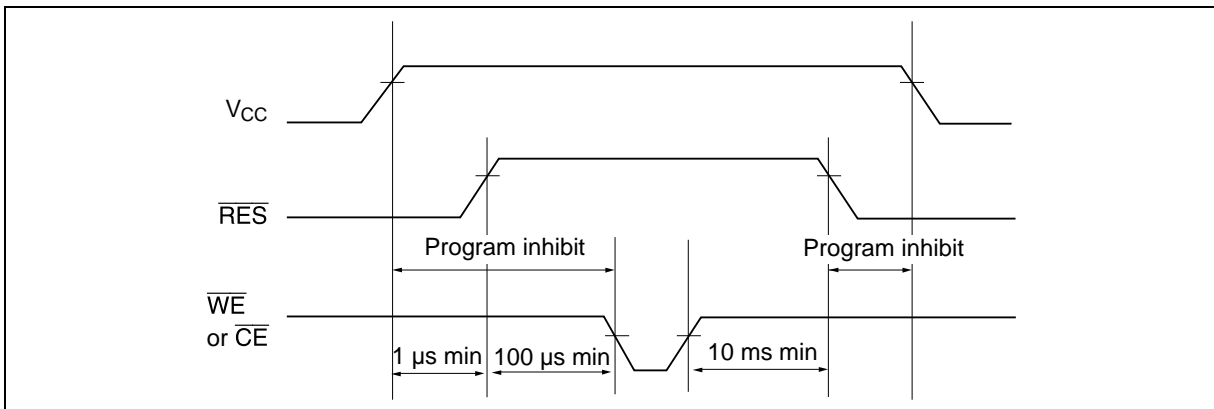

HN58V256A Series, HN58V257A Series

3. Software data protection

To prevent unintentional programming, this device has the software data protection (SDP) mode. The SDP is enabled by inputting the following 3 bytes code and write data. SDP is not enabled if only the 3 bytes code is input. To program data in the SDP enable mode, 3 bytes code must be input before write data.

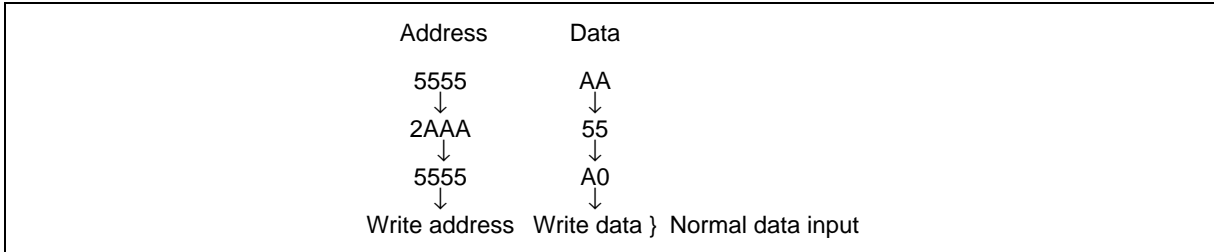

The SDP mode is disabled by inputting the following 6 bytes code. Note that, if data is input in the SDP disable cycle, data can not be written.

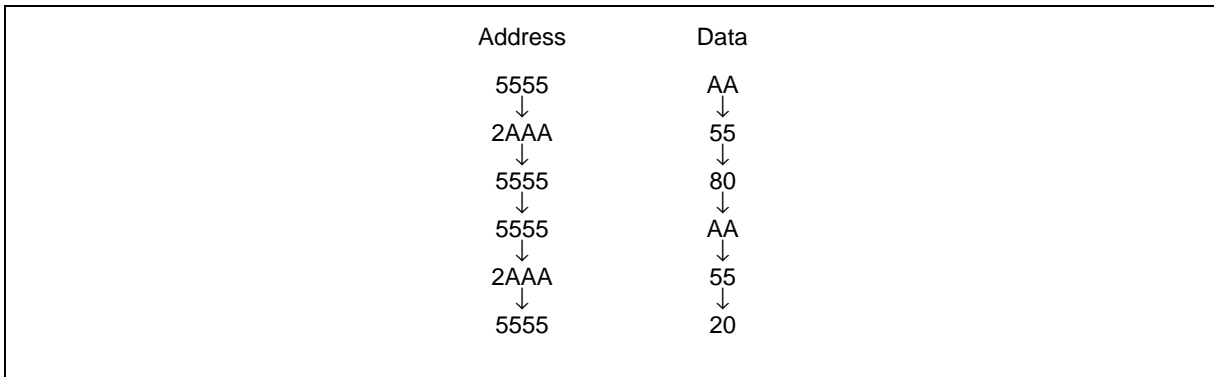

The software data protection is not enabled at the shipment.

Note: There are some differences between Renesas Technology's and other company's for enable/disable sequence of software data protection. If there are any questions, please contact with Renesas Technology's sales offices.

HN58V256A Series, HN58V257A Series

Package Dimensions

HN58V256AFP Series (FP-28D, FP-28DV)

Unit: mm

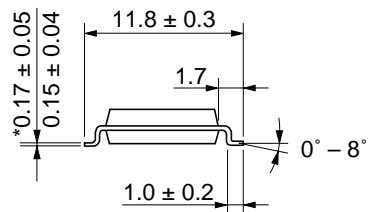
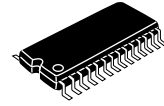
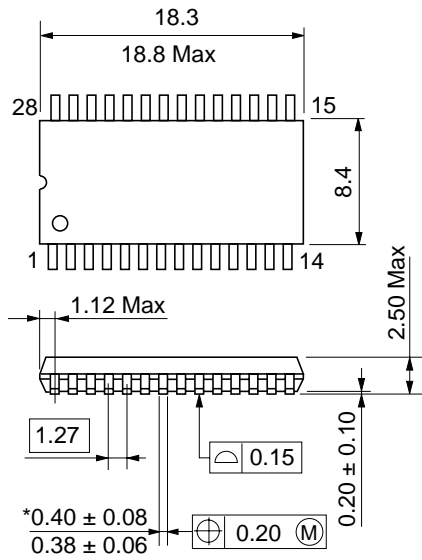

*Dimension including the plating thickness
Base material dimension

Package Code	FP-28D, FP-28DV
JEDEC	Conforms
JEITA	—
Mass (reference value)	0.7 g

HN58V256A Series, HN58V257A Series

Package Dimensions (cont.)

HN58V256AT Series (TFP-28DB, TFP-28DBV)

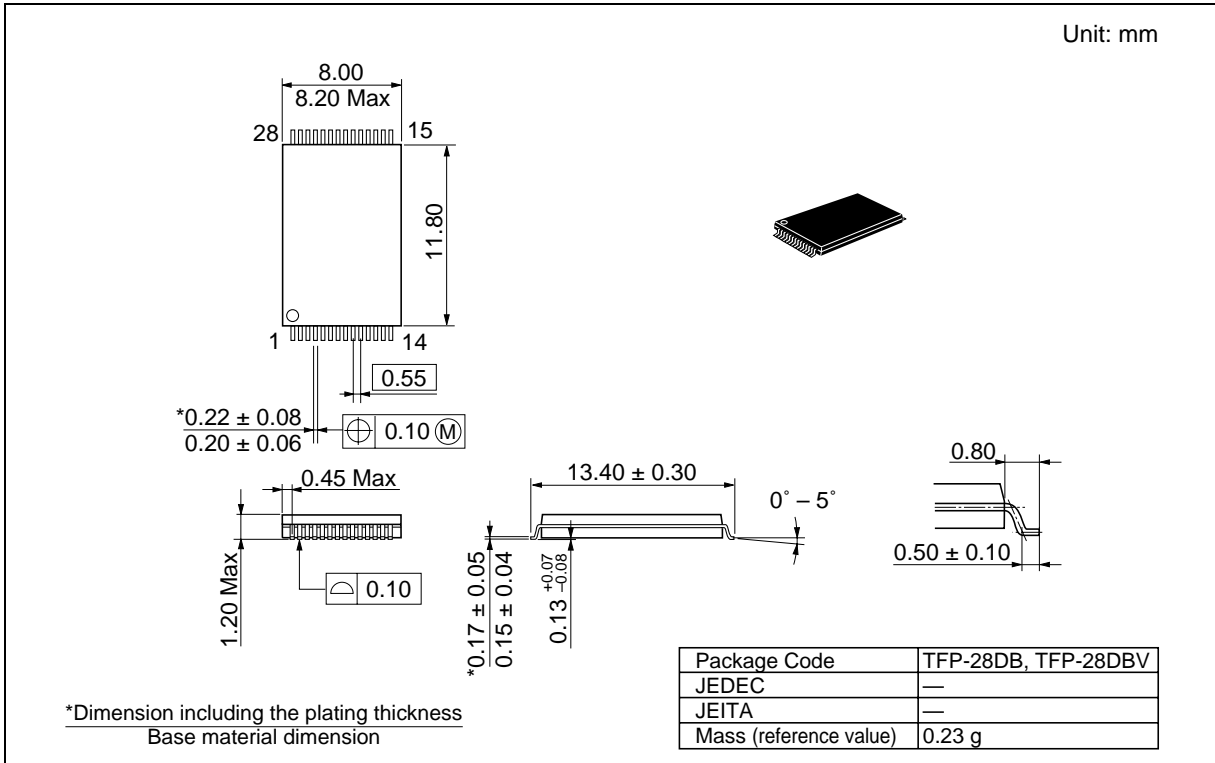

HN58V256A Series, HN58V257A Series

Package Dimensions (cont.)

HN58V257AT Series (TFP-32DA, TFP-32DAV)

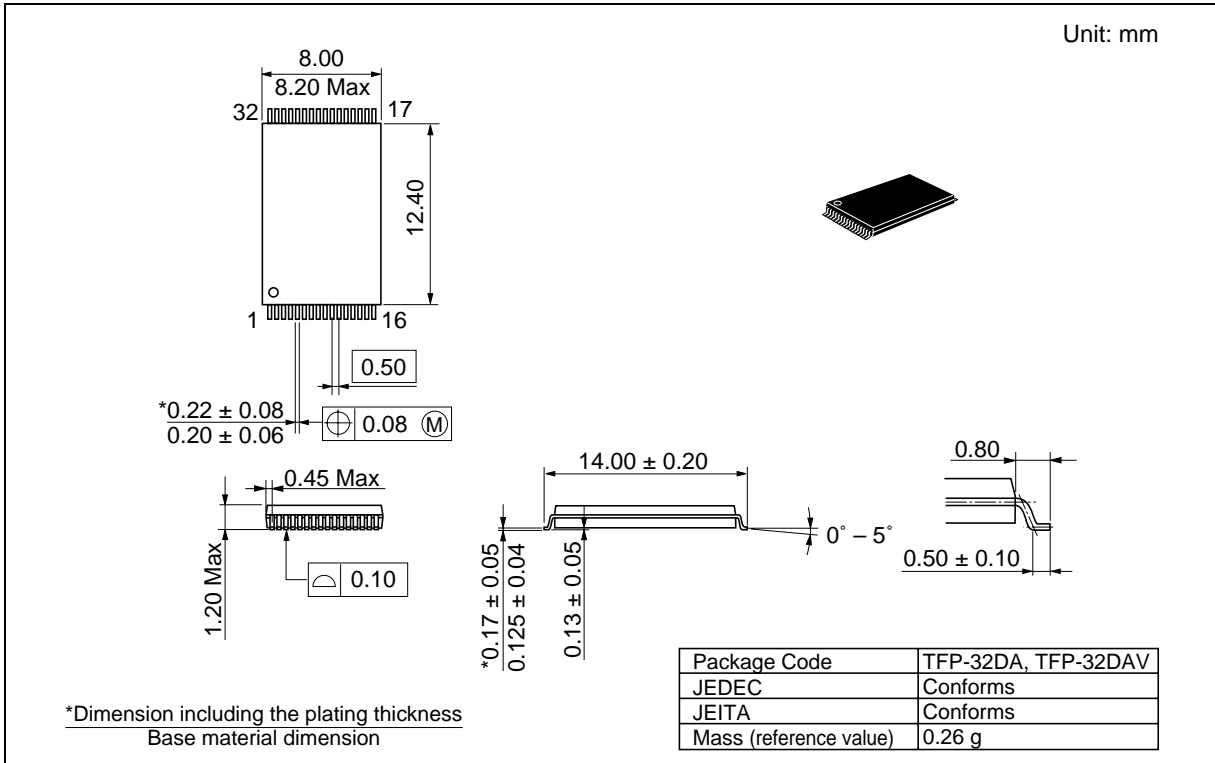

Revision History

HN58V256A/HN58V257A Series Data Sheet

Rev.	Date	Contents of Modification	
		Page	Description
0.0	Mar. 15. 1995	—	Initial issue
0.1	Aug. 7. 1995	—	Determination of package type:
		—	HN58V256AT series (TFP-28DB)
		—	Deletion of HN58V256AP series (DP-28)
		—	Deletion of HN58V256AFPI-12/15
		—	Deletion of HN58V256AT-12SR/15SR
		—	Deletion of HN58V257AT-12SR/15SR
		4	Absolute Maximum Rating
			Deletion of Device Group
			Deletion of Operating temperature range
			– 20 to + 85°C and – 40 to +85°C
		4	Recommended DC Operating Conditions
			Deletion of Device Group
			Deletion of Operating temperature range
			–20/—/85°C and –40/—/85°C
			Deletion of note 4
			Change order of notes
1.0	Apr. 12. 1995	—	Change of format
		2	Operating Information
			Deletion of HN58V256A-15 and HN58V257A-15
			Deletion of note 1
			Deletion of Compatible type No.
			Deletion of Operating temperature range
		3	Pin Description
			Addition of note 1
		3	Block Diagram
			Addition of note 1
		—	Mode Selection
			Addition of note 3
		4	Absolute Maximum Ratings
			Addition of note 4
		4	Recommended DC operating Condition
			V_{IH} (min) 2.4 V to 1.9 V
			Addition of note 4
		5	DC Characteristics
			I_{CC3} (max): 8/12/20/30 mA to 8/12/15/30 mA
		6	AC Characteristics
			Test condition: Input pulse levels: 0 V to 3.0 V to
			0.4 V to 2.4 V ($V_{CC} \leq 3.6$ V), 0.4 V to 3.0 V ($V_{CC} > 3.6$ V)
			Addition of note 2
			Read Timing Waveform: Addition of note 1
			Write Cycle: t_{DS} (min): 50 ns to 70 ns
			Addition of note 4, 5
			Byte Write Timing Waveform (1) and (2): Addition of note 1
			Page Write Timing Waveform (1) and (2): Addition of note 2

Revision Record (cont.)

Rev.	Date	Contents of Modification	
		Page	Description
1.0	Apr. 12. 1995	6	Timing Waveforms Data Polling Timing Waveform: Addition of note 1 Toggle bit Waveform: Addition of note 4
		16	Functional Description Data Protection 2-(2) Addition of figure
2.0	Mar. 4. 1997	16	Functional Description Data protection 3: Addition of note
3.0	May. 20. 1997	16	Functional Description Data protection 3: Change of Description
4.0	Oct. 24. 1997	8	Timing Waveforms Read Timing Waveform: Correct error
5.00	Nov. 17. 2003	—	Change format issued by Renesas Technology Corp.
		2	Ordering Information Addition of HN58V256AFP-12E, HN58V256AT-12E, HN58V257AT-12E
		20-22	Package Dimensions FP-28D to FP-28D, FP-28DV TFP-28DB to TFP-28DB, TFP-28DBV TFP-32DA to TFP-32DA, TFP-32DAV

RENESAS Technology Corp. Sales Strategic Planning Div. Nippon Bldg., 2-6-2, Ohte-machi, Chiyoda-ku, Tokyo 100-0004, Japan

Keep safety first in your circuit designs!

1. Renesas Technology Corp. puts the maximum effort into making semiconductor products better and more reliable, but there is always the possibility that trouble may occur with them. Trouble with semiconductors may lead to personal injury, fire or property damage.
Remember to give due consideration to safety when making your circuit designs, with appropriate measures such as (i) placement of substitutive, auxiliary circuits, (ii) use of nonflammable material or (iii) prevention against any malfunction or mishap.

Notes regarding these materials

1. These materials are intended as a reference to assist our customers in the selection of the Renesas Technology Corp. product best suited to the customer's application; they do not convey any license under any intellectual property rights, or any other rights, belonging to Renesas Technology Corp. or a third party.
 2. Renesas Technology Corp. assumes no responsibility for any damage, or infringement of any third-party's rights, originating in the use of any product data, diagrams, charts, programs, algorithms, or circuit application examples contained in these materials.
 3. All information contained in these materials, including product data, diagrams, charts, programs and algorithms represents information on products at the time of publication of these materials, and are subject to change by Renesas Technology Corp. without notice due to product improvements or other reasons. It is therefore recommended that customers contact Renesas Technology Corp. or an authorized Renesas Technology Corp. product distributor for the latest product information before purchasing a product listed herein.
The information described here may contain technical inaccuracies or typographical errors.
Renesas Technology Corp. assumes no responsibility for any damage, liability, or other loss rising from these inaccuracies or errors.
Please also pay attention to information published by Renesas Technology Corp. by various means, including the Renesas Technology Corp. Semiconductor home page (<http://www.renesas.com>).
 4. When using any or all of the information contained in these materials, including product data, diagrams, charts, programs, and algorithms, please be sure to evaluate all information as a total system before making a final decision on the applicability of the information and products. Renesas Technology Corp. assumes no responsibility for any damage, liability or other loss resulting from the information contained herein.
 5. Renesas Technology Corp. semiconductors are not designed or manufactured for use in a device or system that is used under circumstances in which human life is potentially at stake. Please contact Renesas Technology Corp. or an authorized Renesas Technology Corp. product distributor when considering the use of a product contained herein for any specific purposes, such as apparatus or systems for transportation, vehicular, medical, aerospace, nuclear, or undersea repeater use.
 6. The prior written approval of Renesas Technology Corp. is necessary to reprint or reproduce in whole or in part these materials.
 7. If these products or technologies are subject to the Japanese export control restrictions, they must be exported under a license from the Japanese government and cannot be imported into a country other than the approved destination.
Any diversion or reexport contrary to the export control laws and regulations of Japan and/or the country of destination is prohibited.
 8. Please contact Renesas Technology Corp. for further details on these materials or the products contained therein.
-



RENESAS SALES OFFICES

<http://www.renesas.com>

Renesas Technology America, Inc.
450 Holger Way, San Jose, CA 95134-1368, U.S.A
Tel: <1> (408) 382-7500 Fax: <1> (408) 382-7501

Renesas Technology Europe Limited.
Dukes Meadow, Millboard Road, Bourne End, Buckinghamshire, SL8 5FH, United Kingdom
Tel: <44> (1628) 585 100, Fax: <44> (1628) 585 900

Renesas Technology Europe GmbH
Dornacher Str. 3, D-85622 Feldkirchen, Germany
Tel: <49> (89) 380 70 0, Fax: <49> (89) 929 30 11

Renesas Technology Hong Kong Ltd.
7/F., North Tower, World Finance Centre, Harbour City, Canton Road, Hong Kong
Tel: <852> 2265-6688, Fax: <852> 2375-6836

Renesas Technology Taiwan Co., Ltd.
FL 10, #99, Fu-Hsing N. Rd., Taipei, Taiwan
Tel: <886> (2) 2715-2888, Fax: <886> (2) 2713-2999

Renesas Technology (Shanghai) Co., Ltd.
26/F., Ruijin Building, No.205 Maoming Road (S), Shanghai 200020, China
Tel: <86> (21) 6472-1001, Fax: <86> (21) 6415-2952

Renesas Technology Singapore Pte. Ltd.
1, Harbour Front Avenue, #06-10, Keppel Bay Tower, Singapore 098632
Tel: <65> 6213-0200, Fax: <65> 6278-8001

To our customers,

Old Company Name in Catalogs and Other Documents

On April 1st, 2010, NEC Electronics Corporation merged with Renesas Technology Corporation, and Renesas Electronics Corporation took over all the business of both companies. Therefore, although the old company name remains in this document, it is a valid Renesas Electronics document. We appreciate your understanding.

Renesas Electronics website: <http://www.renesas.com>

April 1st, 2010
Renesas Electronics Corporation

Issued by: Renesas Electronics Corporation (<http://www.renesas.com>)

Send any inquiries to <http://www.renesas.com/inquiry>.

Notice

1. All information included in this document is current as of the date this document is issued. Such information, however, is subject to change without any prior notice. Before purchasing or using any Renesas Electronics products listed herein, please confirm the latest product information with a Renesas Electronics sales office. Also, please pay regular and careful attention to additional and different information to be disclosed by Renesas Electronics such as that disclosed through our website.
2. Renesas Electronics does not assume any liability for infringement of patents, copyrights, or other intellectual property rights of third parties by or arising from the use of Renesas Electronics products or technical information described in this document. No license, express, implied or otherwise, is granted hereby under any patents, copyrights or other intellectual property rights of Renesas Electronics or others.
3. You should not alter, modify, copy, or otherwise misappropriate any Renesas Electronics product, whether in whole or in part.
4. Descriptions of circuits, software and other related information in this document are provided only to illustrate the operation of semiconductor products and application examples. You are fully responsible for the incorporation of these circuits, software, and information in the design of your equipment. Renesas Electronics assumes no responsibility for any losses incurred by you or third parties arising from the use of these circuits, software, or information.
5. When exporting the products or technology described in this document, you should comply with the applicable export control laws and regulations and follow the procedures required by such laws and regulations. You should not use Renesas Electronics products or the technology described in this document for any purpose relating to military applications or use by the military, including but not limited to the development of weapons of mass destruction. Renesas Electronics products and technology may not be used for or incorporated into any products or systems whose manufacture, use, or sale is prohibited under any applicable domestic or foreign laws or regulations.
6. Renesas Electronics has used reasonable care in preparing the information included in this document, but Renesas Electronics does not warrant that such information is error free. Renesas Electronics assumes no liability whatsoever for any damages incurred by you resulting from errors in or omissions from the information included herein.
7. Renesas Electronics products are classified according to the following three quality grades: “Standard”, “High Quality”, and “Specific”. The recommended applications for each Renesas Electronics product depends on the product’s quality grade, as indicated below. You must check the quality grade of each Renesas Electronics product before using it in a particular application. You may not use any Renesas Electronics product for any application categorized as “Specific” without the prior written consent of Renesas Electronics. Further, you may not use any Renesas Electronics product for any application for which it is not intended without the prior written consent of Renesas Electronics. Renesas Electronics shall not be in any way liable for any damages or losses incurred by you or third parties arising from the use of any Renesas Electronics product for an application categorized as “Specific” or for which the product is not intended where you have failed to obtain the prior written consent of Renesas Electronics. The quality grade of each Renesas Electronics product is “Standard” unless otherwise expressly specified in a Renesas Electronics data sheets or data books, etc.
 - “Standard”: Computers; office equipment; communications equipment; test and measurement equipment; audio and visual equipment; home electronic appliances; machine tools; personal electronic equipment; and industrial robots.
 - “High Quality”: Transportation equipment (automobiles, trains, ships, etc.); traffic control systems; anti-disaster systems; anti-crime systems; safety equipment; and medical equipment not specifically designed for life support.
 - “Specific”: Aircraft; aerospace equipment; submersible repeaters; nuclear reactor control systems; medical equipment or systems for life support (e.g. artificial life support devices or systems), surgical implantations, or healthcare intervention (e.g. excision, etc.), and any other applications or purposes that pose a direct threat to human life.
8. You should use the Renesas Electronics products described in this document within the range specified by Renesas Electronics, especially with respect to the maximum rating, operating supply voltage range, movement power voltage range, heat radiation characteristics, installation and other product characteristics. Renesas Electronics shall have no liability for malfunctions or damages arising out of the use of Renesas Electronics products beyond such specified ranges.
9. Although Renesas Electronics endeavors to improve the quality and reliability of its products, semiconductor products have specific characteristics such as the occurrence of failure at a certain rate and malfunctions under certain use conditions. Further, Renesas Electronics products are not subject to radiation resistance design. Please be sure to implement safety measures to guard them against the possibility of physical injury, and injury or damage caused by fire in the event of the failure of a Renesas Electronics product, such as safety design for hardware and software including but not limited to redundancy, fire control and malfunction prevention, appropriate treatment for aging degradation or any other appropriate measures. Because the evaluation of microcomputer software alone is very difficult, please evaluate the safety of the final products or system manufactured by you.
10. Please contact a Renesas Electronics sales office for details as to environmental matters such as the environmental compatibility of each Renesas Electronics product. Please use Renesas Electronics products in compliance with all applicable laws and regulations that regulate the inclusion or use of controlled substances, including without limitation, the EU RoHS Directive. Renesas Electronics assumes no liability for damages or losses occurring as a result of your noncompliance with applicable laws and regulations.
11. This document may not be reproduced or duplicated, in any form, in whole or in part, without prior written consent of Renesas Electronics.
12. Please contact a Renesas Electronics sales office if you have any questions regarding the information contained in this document or Renesas Electronics products, or if you have any other inquiries.

(Note 1) “Renesas Electronics” as used in this document means Renesas Electronics Corporation and also includes its majority-owned subsidiaries.

(Note 2) “Renesas Electronics product(s)” means any product developed or manufactured by or for Renesas Electronics.