

STEERING DIODE / TVS ARRAY COMBO

APPLICATIONS

- ✓ Ethernet - 10/100 Base T
- ✓ Computer I/O Ports - SCSI, FireWire & USB
- ✓ Set-Top Box Protection
- ✓ Video Card

IEC COMPATIBILITY (EN61000-4)

- ✓ 61000-4-2 (ESD): Air - 15kV, Contact - 8kV
- ✓ 61000-4-4 (EFT): 40A - 5/50ns
- ✓ 61000-4-5 (Surge): 24A, 8/20 μ s - Level 2(Line-Gnd) & Level 3(Line-Line)

FEATURES

- ✓ 500 Watts Peak Pulse Power per Line (tp=8/20 μ s)
- ✓ Unidirectional Configuration
- ✓ Available in 4 Voltage Types: 3.3V to 15V
- ✓ Protects Up to Four (4) I/O Ports
- ✓ ESD Protection > 40 kilovolts
- ✓ **LOW CAPACITANCE: 15pF**
- ✓ RoHS Compliant in Lead-Free Versions

MECHANICAL CHARACTERISTICS

- ✓ Molded JEDEC SO-8 Package
- ✓ Weight 70 milligrams (Approximate)
- ✓ Available in Tin-Lead or Lead-Free Pure-Tin Plating(Annealed)
- ✓ Solder Reflow Temperature:
 - Tin-Lead - Sn/Pb, 85/15: 240-245°C
 - Pure-Tin - Sn, 100: 260-270°C
- ✓ Flammability rating UL 94V-0
- ✓ 12mm Tape and Reel Per EIA Standard 481
- ✓ Marking: Logo, Marking Code, Date Code & Pin One Defined By Dot on Top of Package



PIN CONFIGURATION

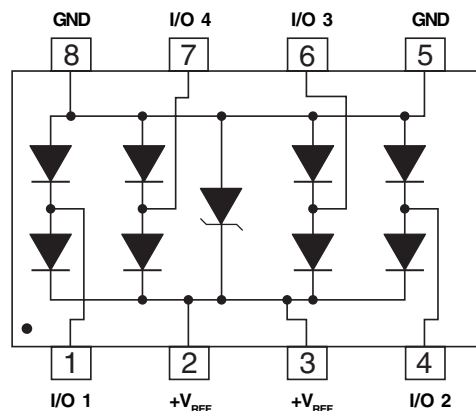

DEVICE CHARACTERISTICS

MAXIMUM RATINGS @ 25°C Unless Otherwise Specified			
PARAMETER	SYMBOL	VALUE	UNITS
Peak Pulse Power ($t_p = 8/20\mu s$) - See Figure 1	P_{PP}	500	Watts
Operating Temperature	T_J	-55°C to 150°C	°C
Storage Temperature	T_{STG}	-55°C to 150°C	°C
Maximum Forward Voltage @ 100mA (See Note 1)	V_F	1.1	Volts

Note 1: Measured between pins 8 or 5 to 1, 2, 3, 4, 6 and 7.

ELECTRICAL CHARACTERISTICS PER LINE @ 25°C Unless Otherwise Specified							
PART NUMBER	DEVICE MARKING	RATED STAND-OFF VOLTAGE V_{WM} VOLTS	MINIMUM BREAKDOWN VOLTAGE @ 1mA $V_{(BR)}$ VOLTS	MAXIMUM CLAMPING VOLTAGE (See Fig. 2) @ $I_P = 1A$ V_C VOLTS	MAXIMUM CLAMPING VOLTAGE (See Fig. 2) @ 8/20 μs $V_C @ I_{PP}$	MAXIMUM LEAKAGE CURRENT @ V_{WM} I_D μA	MAXIMUM CAPACITANCE (See Note 1) (See Figure 5) @ 0V, 1 MHz $C_{I(SD)}$ pF
PSRDA05-4	PRB	5.0	6.0	9.8	13.5V @ 42.0A	20	15
PSRDA12-4	PRD	12.0	13.3	19.0	25.9V @ 21.0A	1	15
PSRDA15-4	PRE	15.0	16.7	24.0	30.0V @ 17.0A	1	15

Note 1: Capacitance measured at $V_{WM} = V_{CC}$ connected between I/O pins to pin 8 and 5 (Gnd). $V_R = V_{WM} @ 1MHz$. As shown in Figure 5, REF1 is connected to ground, REF2 is connected to $+V_{CC}$, and input applies to $V_{CC} = 5V$, $V_{sig} = mV$, $F = 1 MHz$.

**FIGURE 1
PEAK PULSE POWER VS PULSE TIME**

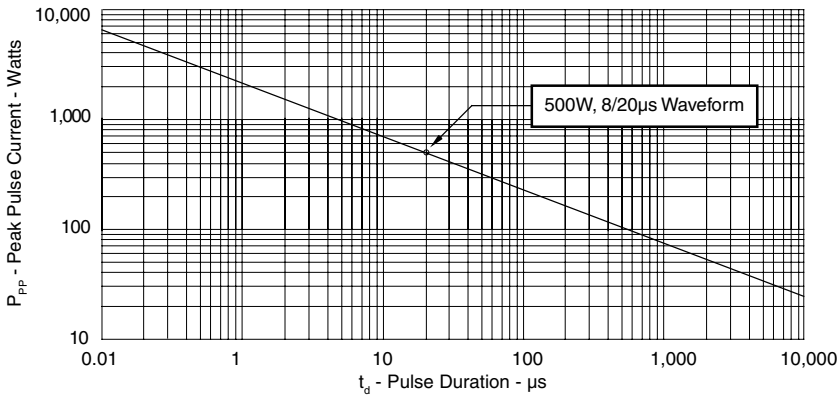

**FIGURE 2
PULSE WAVE FORM**

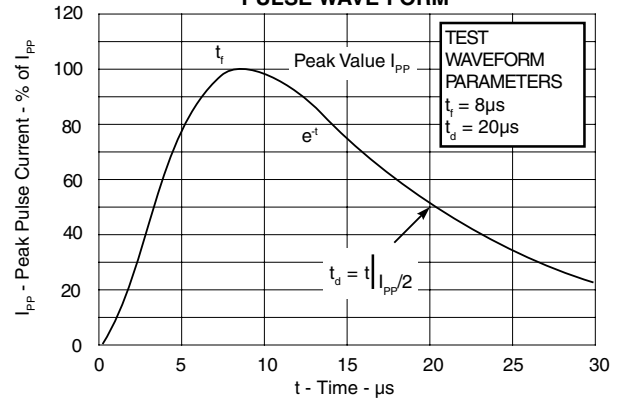

GRAPHS

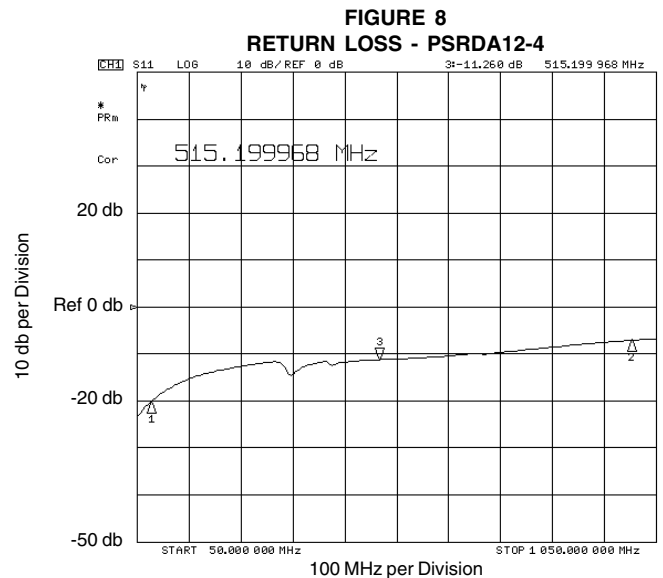
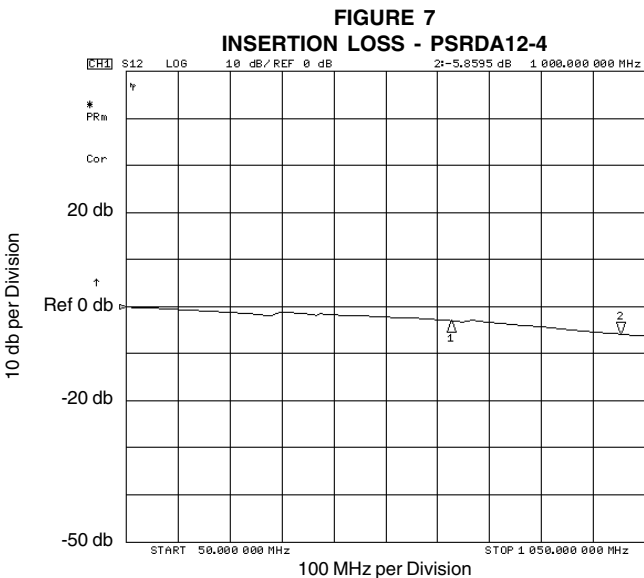
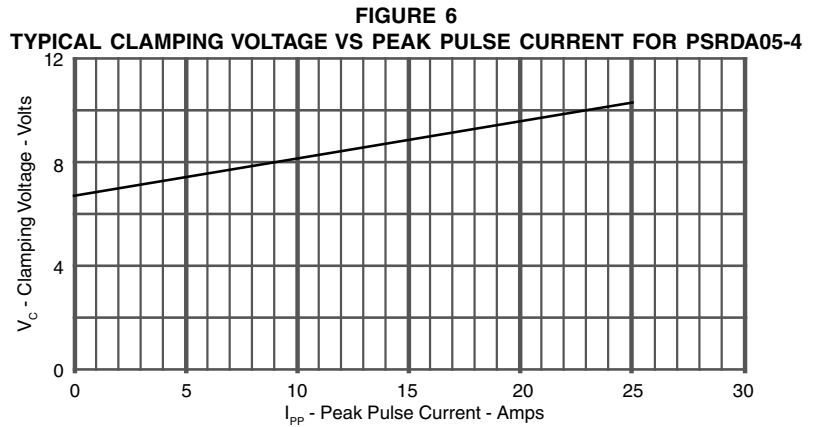
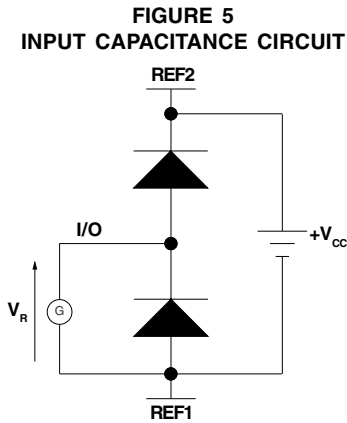
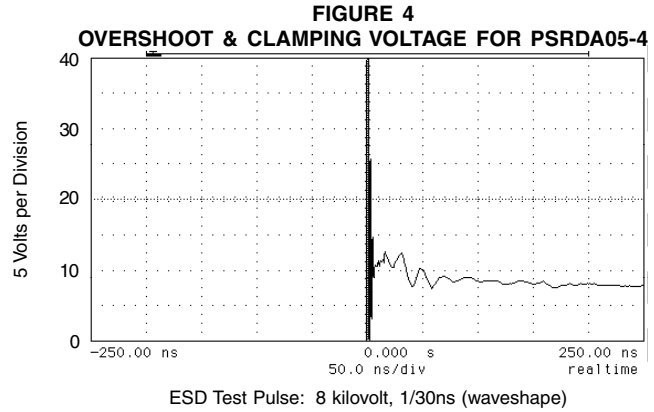
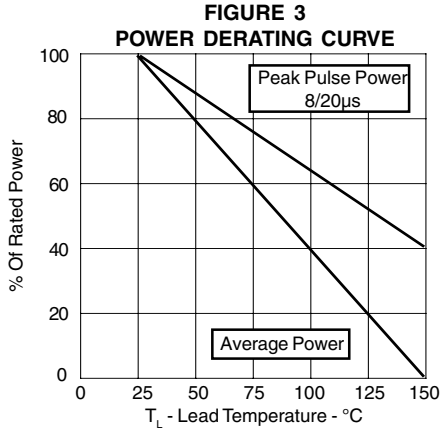

APPLICATION NOTE

The PSRDAxx-4 Series are low capacitance, unidirectional TVS arrays that are designed to protect I/O or high speed data lines from the damaging effects of ESD or EFT. This product series has a surge capability of 500 Watts P_{pp} per line for an 8/20 μ s waveshape and offers ESD protection > 40kV.

DIFFERENTIAL-MODE CONFIGURATION (Figure 1)

Ideal for use in USB applications, the PSRDAxx-4 Series provides up to four (4) lines of protection in a differential-mode configuration as depicted in Figure 1.

Circuit connectivity is as follows:

- ✓ Pins 1, 4, 6 and 7 are connected to the data lines.
- ✓ Pins 5 and 8 are connected to ground.
- ✓ Pins 2 and 3 are connected to the databus.

DIFFERENTIAL-MODE CONFIGURATION (Figure 2)

The PSRDAxx-4 Series also provides up to four (4) lines of protection in a differential-mode configuration as depicted in Figure 2 for T1/E1 applications.

Circuit connectivity is as follows:

- ✓ Pins 1, 4, 6 and 7 are connected to the data lines.
- ✓ Pins 5 and 8 are connected to ground.
- ✓ Pins 2 and 3 are connected to the databus.

CIRCUIT BOARD LAYOUT RECOMMENDATIONS

Circuit board layout is critical for Electromagnetic Compatibility (EMC) protection. The following guidelines are recommended:

- ✓ The protection device should be placed near the input terminals or connectors, the device will divert the transient current immediately before it can be coupled into the nearby traces.
- ✓ The path length between the TVS device and the protected line should be minimized.
- ✓ All conductive loops including power and ground loops should be minimized.
- ✓ The transient current return path to ground should be kept as short as possible to reduce parasitic inductance.
- ✓ Ground planes should be used whenever possible. For multilayer PCBs, use ground vias.

Figure 1. Typical Differential-Mode USB Protection

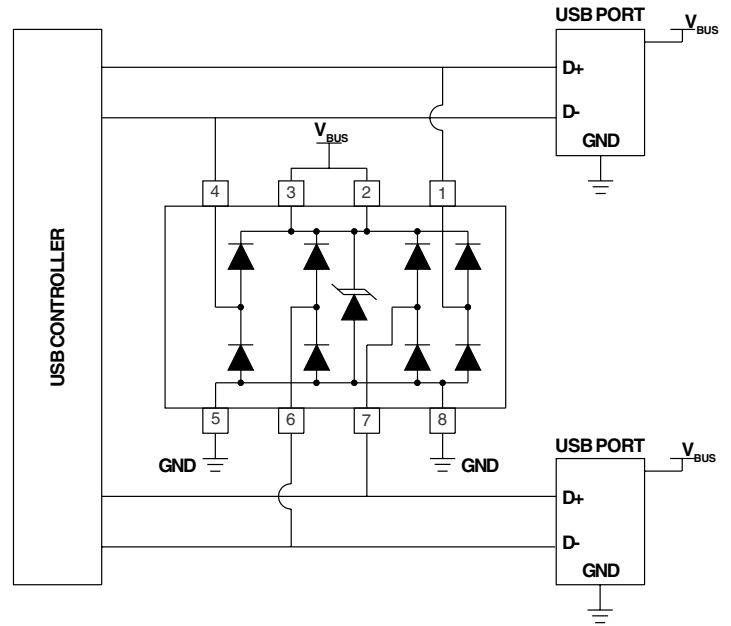
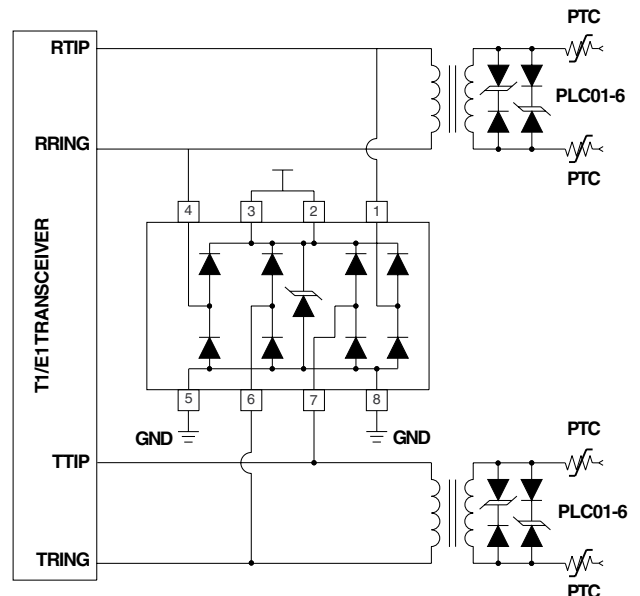
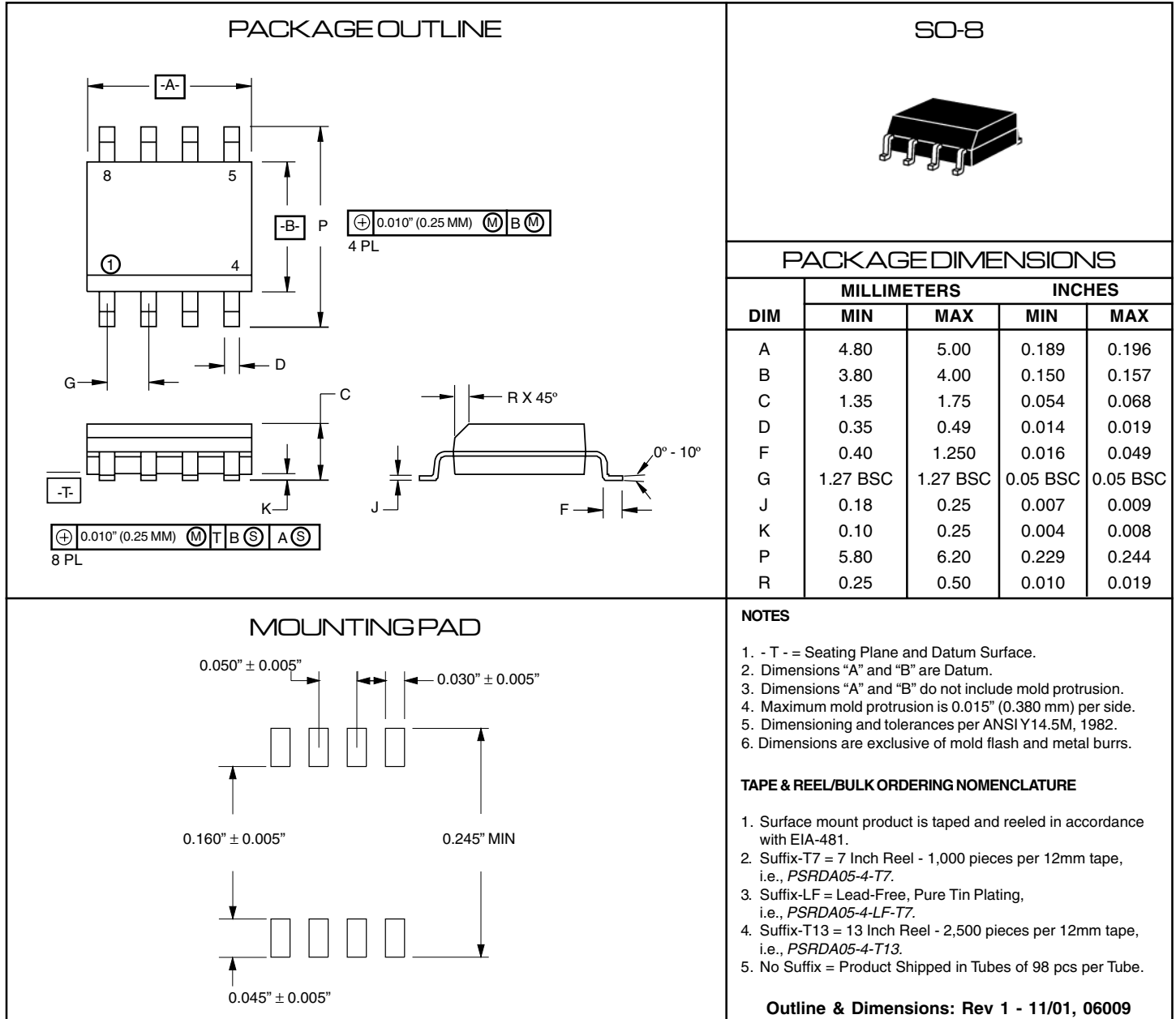

Figure 2. Typical Differential-Mode T1/E1 Protection



PACKAGE OUTLINE & DIMENSIONS



COPYRIGHT © ProTek Devices 2005

SPECIFICATIONS: ProTek reserves the right to change the electrical and or mechanical characteristics described herein without notice (except JEDEC).

DESIGN CHANGES: ProTek reserves the right to discontinue product lines without notice, and that the final judgement concerning selection and specifications is the buyer's and that in furnishing engineering and technical assistance, ProTek assumes no responsibility with respect to the selection or specifications of such products.

ProTek Devices
2929 South Fair Lane, Tempe, AZ 85282
Tel: 602-431-8101 Fax: 602-431-2288
E-Mail: sales@protekdevices.com
Web Site: www.protekdevices.com