

ABSOLUTE ROTARY ENCODER SSI



Main Features

- Compact and heavy-duty industrial model
- Interface: Synchronous-serial (RS 422)
- Housing: 58 mm Ø
- Shaft: 6 or 10 mm Ø
- Hollow shaft 12 mm Ø
- Blind hollow shaft 15 mm Ø
- Max. 65,536 steps per revolution (16 bit)
- Max. 16,384 revolution (14 bit)
- Preset input / Incremental output (optional)
- Code: Gray or Binary
- EMC: EN 61000-6-2, EN 61000-6-4

Mechanical Structure

- Aluminum flange and housing
- Stainless steel shaft
- Precision ball bearings with sealing or cover rings
- Code disc made of unbreakable and durable plastic

Applications

- Sensing of
- Angles
- Distances
- Tracks
- Inclinations
- Differences between two or more axes

Electrical Features

- Temperature insensitive IR-opto-receiver-ASIC with integrated signal conditioning
- Only one IR-transmitter-diode per opto-ASIC
- Highly integrated circuit in SMD -technology
- Polarity inversion protection
- Over-voltage-peak protection

ABSOLUTE ROTARY ENCODER SSI

Technical data

Electrical data

Clock input	Via opto-coupler
Data output	Line-driver according to RS 422
Clock frequency	100 kHz - 2 MHz
Step frequency LSB	Max. 800 kHz (internal)
Accuracy of division	$\pm 1/2$ LSB (12 bit), ± 2 LSB (16 bit)
Supply voltage	10-30 V DC (absolute limits) *
Cycle time (Preset)	> 150 μ s (only interface S1, S3, S4)
Turn on time	< 1 s
Power consumption	Interface SL / S1 / S4 max. 1 W; interface S2 / S3 max. 1.5 W
Electrical lifetime	> 10 ⁵ h
EMC	Emitted interference: EN 61000-6-4
	Noise immunity: EN 61000-6-2
Connection	Connector or cable exit 1m

* Supply voltage according to EN 50 178 (safety extra-low voltage)

Mechanical data

Housing	Aluminum, optional stainless steel
Lifetime	Dependent on shaft version and shaft loading – refer to table
Max. shaft loading	Axial 40 N, radial 110 N
Inertia of rotor	≤ 30 gcm ²
Friction torque	≤ 3 Ncm (without shaft sealing)
RPM (continuous operation)	max. 12,000 RPM, Hollow shaft (T): max. 3,000 RPM
Shock (EN 60068-2-27)	≤ 100 g (half sine, 6 ms)
Permanent shock (EN 60028-2-29)	≤ 10 g (half sine, 16 ms)
Vibration (EN 60068-2-6)	≤ 10 g (10 Hz ... 1,000 Hz)
Weight (standard version)	Single turn: ≈ 200 g, Single turn Hollowshaft (T): 300 g
	Multi turn: ≈ 300 g
Weight (stainless steel version)	Single turn: ≈ 400 g, Single turn Hollowshaft (T): 600 g
	Multi turn: ≈ 600 g

Flange	Synchro (S)		Clamp (C)	Blind hollow shaft (B)	Hollow shaft (T)
	6 mm	10 mm	10 mm	15 mm	12 mm
Shaft diameter	6 mm	10 mm	10 mm	15 mm	12 mm
Shaft length	10 mm	20 mm	20 mm	-	-
Hollow shaft depth min. / max.	-	-	-	15 mm / 30 mm	continuous

ABSOLUTE ROTARY ENCODER SSI

Minimum (mechanical) lifetime

Flange	Lifetime in 10 ⁸ revolutions with F _a / F _r		
	40 N / 60 N	40 N / 80 N	40 N / 110 N
C10 (Clamp flange 10 x 20)	247	104	40
S10 (Synchro flange 10 x 20)	216	91	35
S6 (Synchro flange 6 x 10) without shaft sealing	713	301	116

S6 (Synchro flange 6 x 10) with shaft sealing: max. 20 N axial, 80 N radial

Environmental Conditions

Operating temperature	- 40 ... + 85 °C *
Storage temperature	- 40 ... + 85 °C *
Humidity	98 % (without liquid state)
Protection Class (EN 60529)	Casing side: IP 65
	Shaft side: IP 64 (optional with shaft sealing: IP66)
Protection Class (EN 60529) Hollow shaft	IP 64

* Cable exit: -30 ... + 70 °C (static), -5 ... + 70 °C (flexing)

Interface

Synchronous Serial Interface (SSI)

Driver	Driver meets EIA standard RS 422; transmission rates up to 10 MBit/s
Transfer	Transfer distance up to 1,200 m
Transmission	Balanced transmission provides high noise immunity
Pair lines	Shielded and twisted pair lines are essential to attain extremely high noise immunity
Interface	For a detailed description of the synchronous-serial interface (SSI) refer to introduction section.
Optional	Built-in RS 422 interface for bus mode (strobe-function). Up to 10 encoders can be used on the same data line !

Detailed description for SSI-Interface under www.posital.de

ABSOLUTE ROTARY ENCODER SSI

Reading position value (Single transfer)

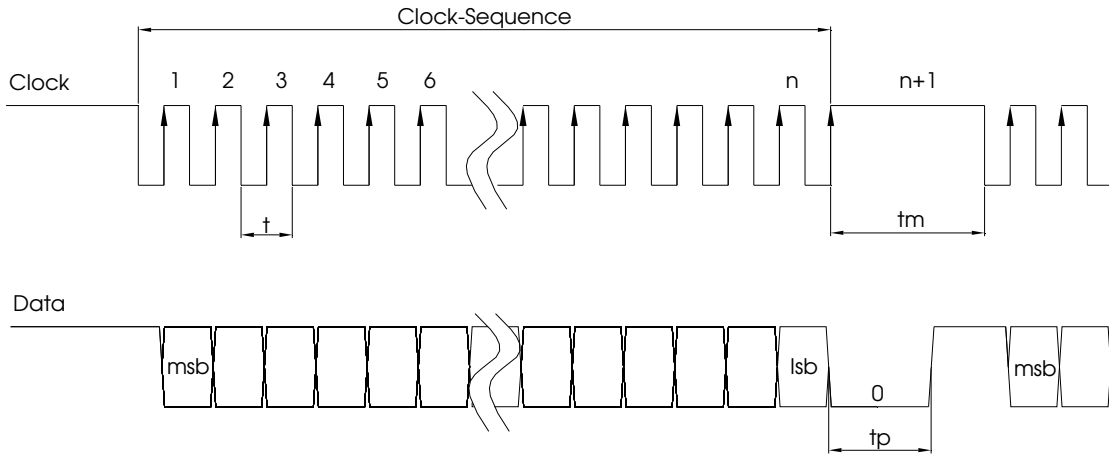

Reading position value multiple times (Multiple transfer)

FRABA SSI encoders use the "multiple transfer" to read a position value multiple times. If a pause does not come after the clock sequence, the encoder will repeat the position value. This will continue until the proper pause (t_m) occurs. The multiple transfer of the same data allows the control system to recognize transfer errors.

Some PLC's require a "0" after the last transmitted bit (lsb). For this reason, the "multiple transfer" feature on single turn encoders with more than 13 bits can be disabled (optional) for PLC's that provide only the SSI-formats 13, 21 and 25 bits. This feature is factory set and must be requested when ordering.

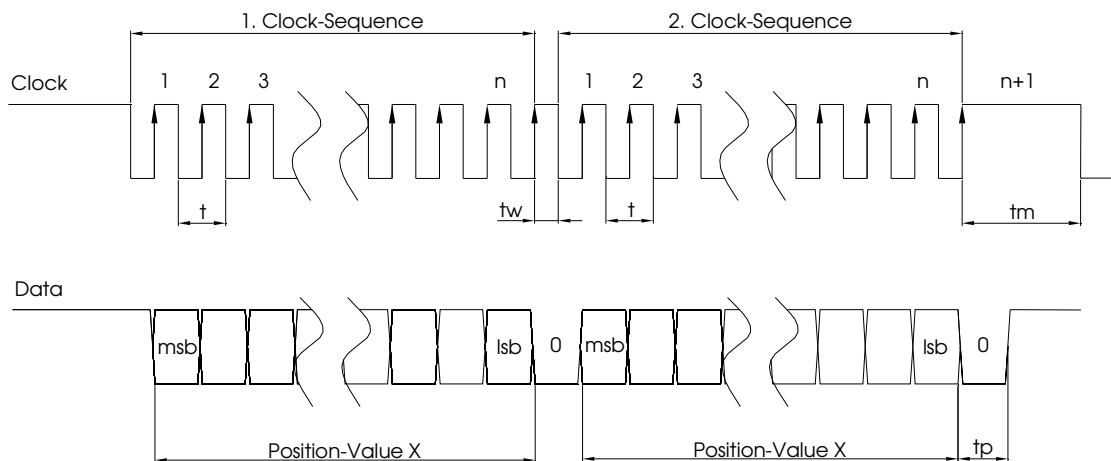

ABSOLUTE ROTARY ENCODER SSI

Preset function (only for interface S1, S3 or S4)

Preset value = 0 will be set after falling edge or end of pushing preset push-button (only version

S4). This function should be only used on a standstill shaft.

Preset push-button (see sketch, only interface S4)

LED Display	Function
Green	On = power supply is connect to the encoder. Turn off during pushing the preset push-button.
Red	On = Alarm message if LED reaches a lower light level (with normal data output) or memory failure (data bits will set continuous to "high")

Incremental outputs (only in interface S2 or S3)

Output of 1024 pulse per turn i.e. to grasp the velocity for a motor control system. Signal A and B are shifted to detect the rotarv direction.

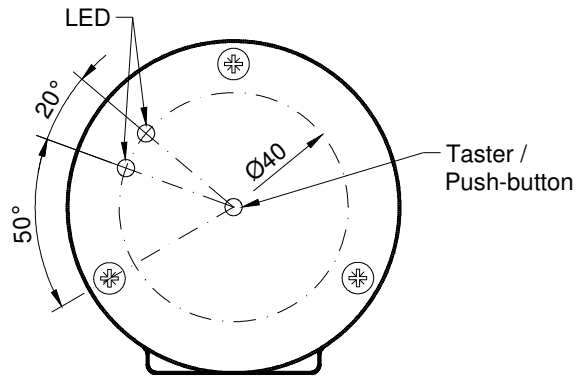

No. of increments	1024
Signals	Channel A, /A, B, /B
Driver	Line driver RS 422
Phase offset	90° between A and B (< 10%)
Output frequency	Max. 800 kHz

ABSOLUTE ROTARY ENCODER SSI

Electrical connection

Interface	12 pol. Connector Pin-Nr.				Wire end	
	SL	S1 / S4	S2	S3	SL	S1
Clock -	1	1	1	1	yellow	yellow
Clock +	2	2	2	2	green	green
Data +	3	3	3	3	grey	grey
Data -	4	4	4	4	pink	pink
Complement	8	8	8	8	red	red
+ U _b = 10-30 V	11	11	11	11	brown	brown
GND	12	12	12	12	white	white
Preset	-	9	-	9		black
A	-		5	5		
/A	-		6	6		
B	-		7	7		
/B	-		10	10		
Shielding	-	-	-	-	Shielding	Shielding

Pinning encoder (male)

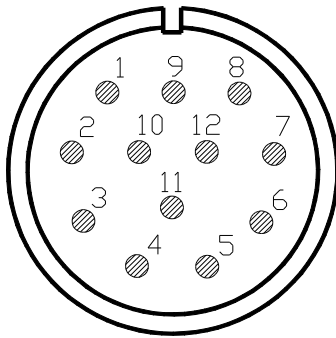

Complement input		Encoder counting direction for clockwise rotation (looking onto the shaft)
Function	Level	
Direction of rotation	0 (Input = N.C. * or GND)	Up
	1 (Input = + U _b or ≥ 4,5 V)	Down

Preset input (only for interface S1, S3, S4)		
Function	Level	
Preset value = 0	0 (Input: N.C. * or GND)	Output position value
	1 (Input = + U _b or ≥ 4,5 V)	Set on falling edge (min. 100 ms)

* no ledge on connector disposed

ABSOLUTE ROTARY ENCODER SSI

Mechanical Drawings

Synchro flange (S)

Available two versions

Synchro flange	d / mm	l / mm
Version S06	6 _{f6}	10
Version S10	10 _{h8}	20

Cable exit (Cable = \varnothing 8mm)

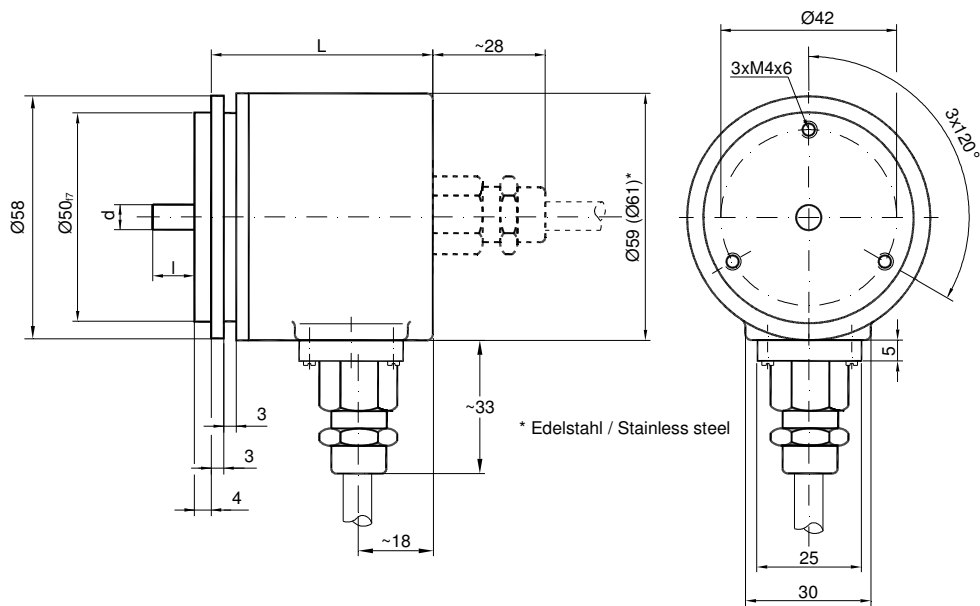

12 pol. Connector (for \varnothing 6-9 mm cable, stainless steel* drawings on request)

		L
Single-Turn	axial	42
	radial / axial*	53
Multi-Turn	axial	53
	radial	53

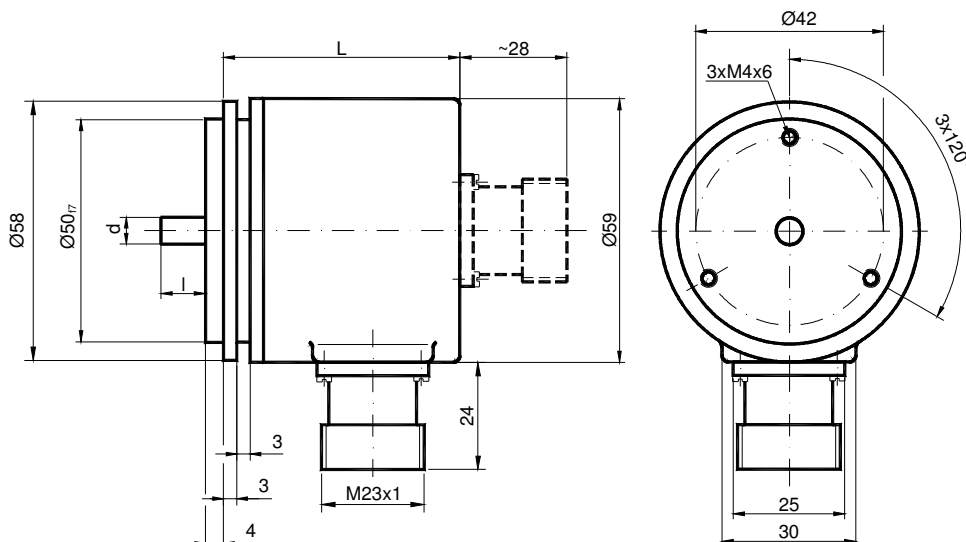

ABSOLUTE ROTARY ENCODER SSI

Clamp flange (C10)

Cable exit (Cable = \varnothing 8 mm)

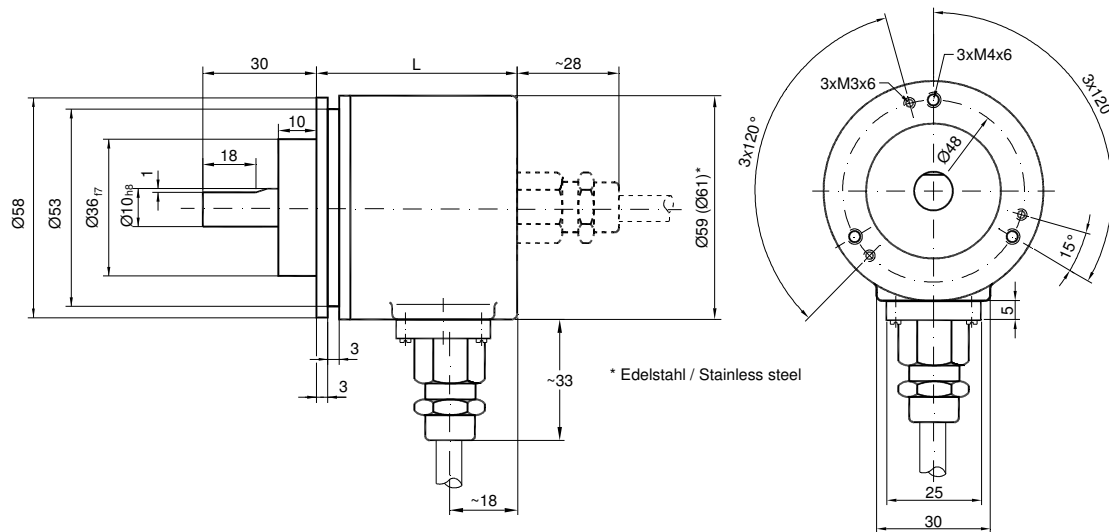

12 pol. Connector (for \varnothing 6-9 mm cable,
stainless steel* drawings on request)

		L
Single-Turn	axial	42
	radial / axial*	53
Multi-Turn	axial	53
	radial	53

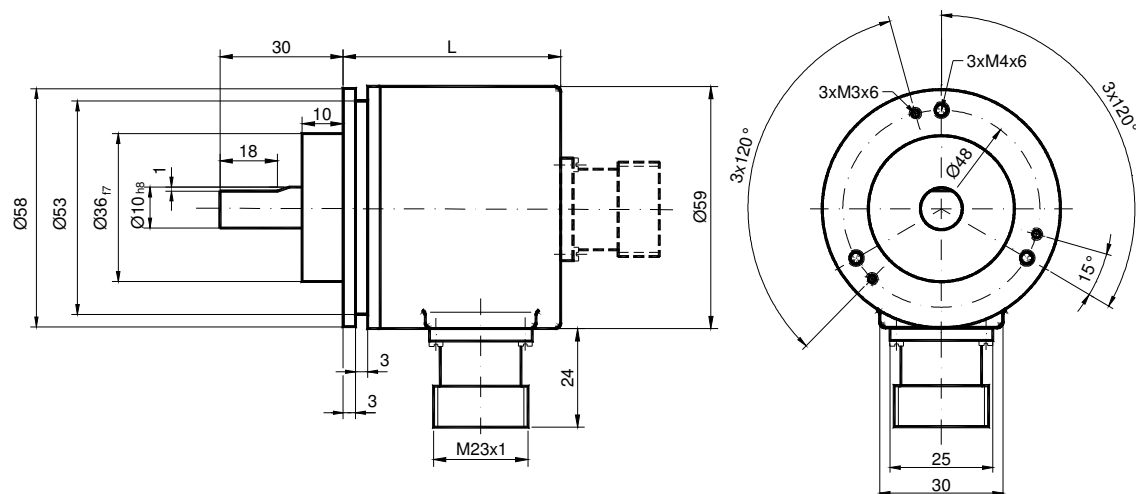

ABSOLUTE ROTARY ENCODER SSI

Hollow shaft (T)

12 pol. Connector (for \varnothing 6-9 mm cable)

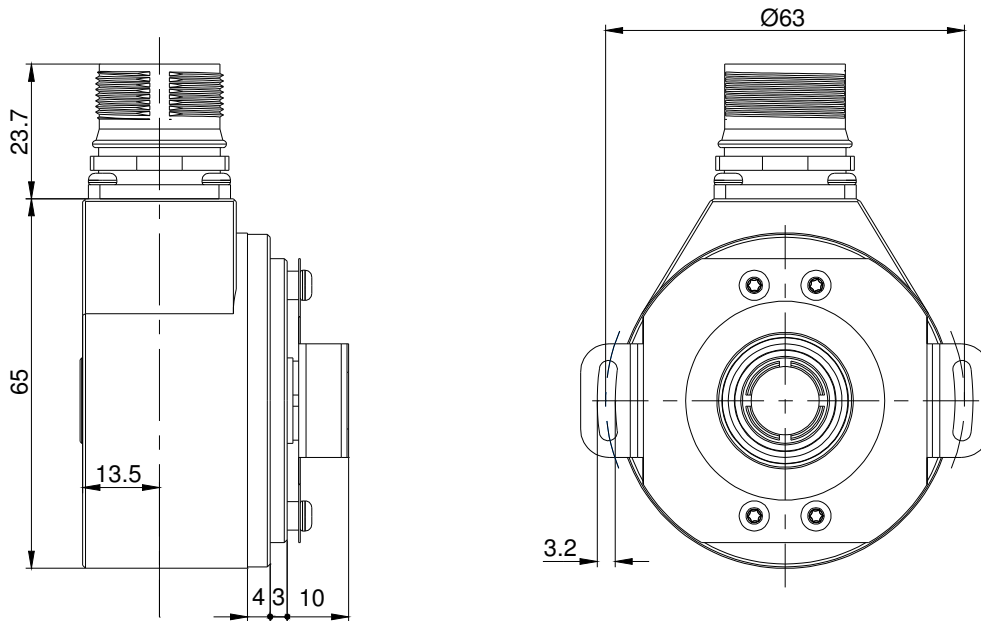

Cable exit (Cable = \varnothing 8 mm)

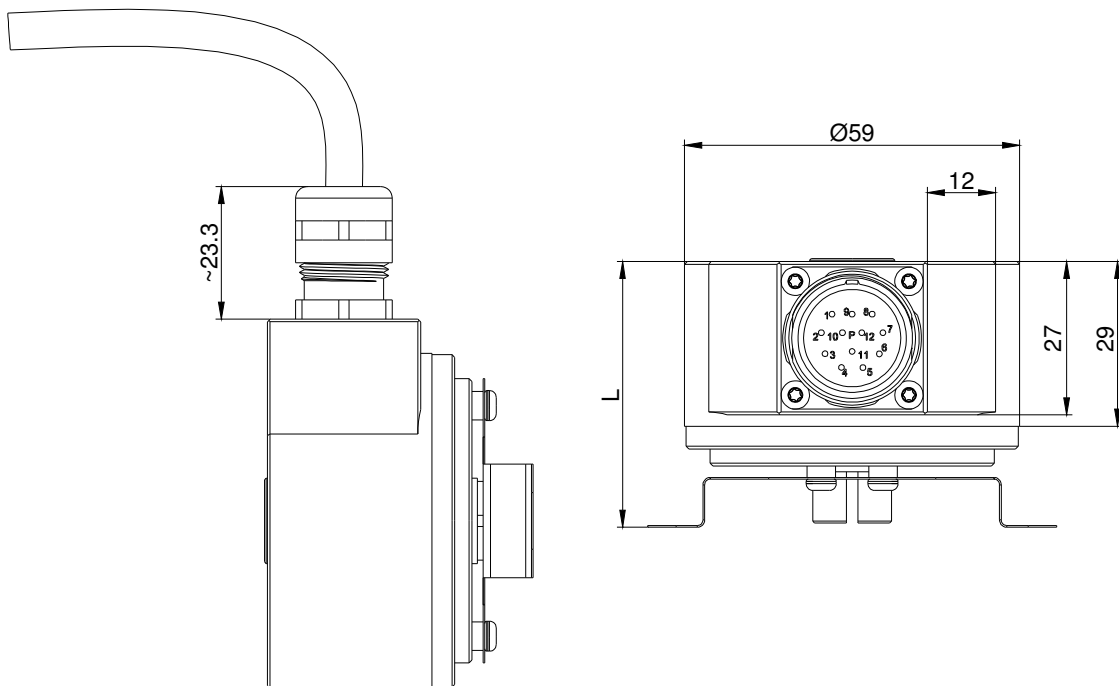

Mounting instruction see on the next side

ABSOLUTE ROTARY ENCODER SSI

Blind hollow shaft (B)

With cable exit available too. See drawing clamp flange.

(Stainless steel* and cable exit drawings on request)

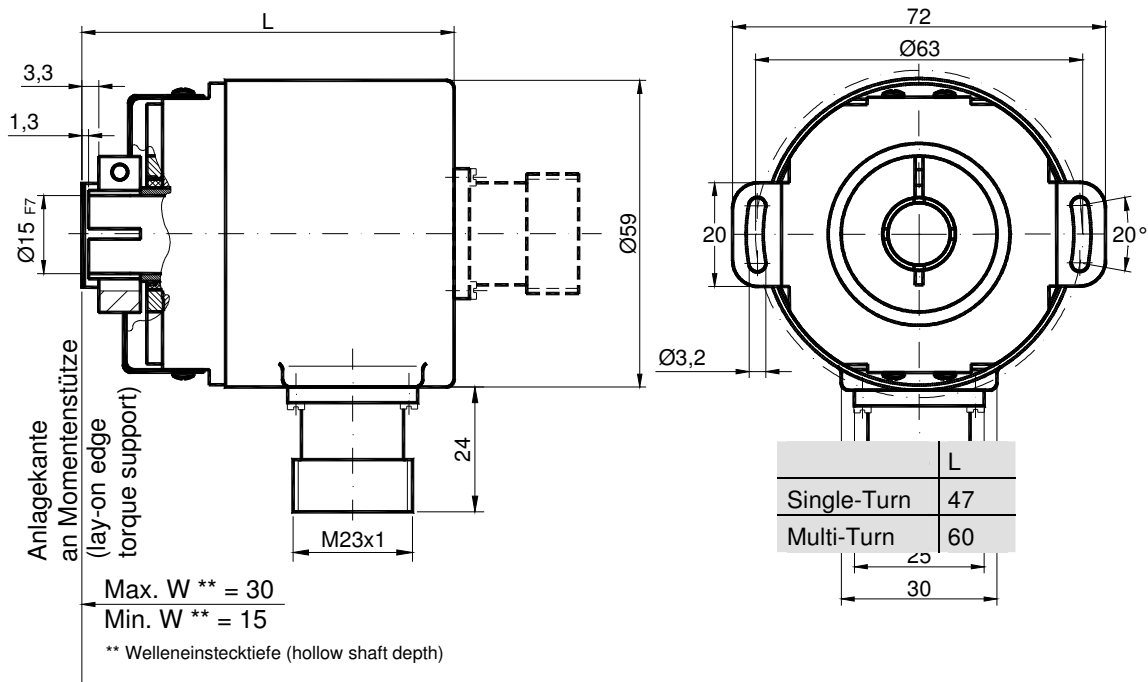

		L
Single-Turn	axial	61
	radial / axial*	72
Multi-Turn	axial	72
	radial	72

Mounting instructions

The clamp ring should only be tightened if the shaft of the driving element is inserted into the hollow shaft.

The diameter of the blind hollow shaft can be reduced to different diameters (see accessories) by using an adapter (this reducing adapter can be pushed into the hollow shaft).

Maximum radial and axial misalignment of the drive shaft:

	axial	radial
static	± 0.3 mm	± 0.5 mm
dynamic	± 0.1 mm	± 0.2 mm

ABSOLUTE ROTARY ENCODER SSI

Models / Ordering Description

Description	Type key						
Optocode	OCD-	__	00	-	-	-	-
Interface SSI		SL					
	Preset	S1					
	Inkr.	S2					
	Preset + Inkr.	S3					
	Preset button *	S4					
Version			00				
Code	Gray			G			
	Binary			B			
Bits for Revolutions	Single turn				00		
	Multi turn (4,096 turns)				12		
	Multi turn (16,384 turns)				14		
Steps per revolution	4,096 (0.09°)				12		
(Bits)	8,192 (0.04°)				13		
	65,536 (0.005°)				16		
Flange	Clamp flange					C	
	Synchro flange					S	
	Blind hollow shaft					B	
	Hollow shaft					T	
Shaft diameter	06 mm					06	
	10 mm					10	
	12 mm (Hollow shaft)					12	
	15 mm (Blind hollow shaft)					15	
Mechanical options	Without						0
	Shaft sealing (IP66)						S
	Stainless Steel						V
	Customized						C
Connection	Connector, axial **						PAL
	Connector, radial						PRL
	1m cable exit, axial **						CAW
	1m cable exit, radial *						CRW

Standard = bold, further models on request

UL certificated models on request

* unavailable in stainless steel

** unavailable with interface S4 or hollow shaft (T)

ABSOLUTE ROTARY ENCODER SSI

Accessories and Documentation

Description		Type
Connector, counterpart	Circular connector, 12 pins	1KG
Cable for 1KG/PAL	4 x 2 x 0,14 mm ² + 2 x 0,5 mm ²	ST-K4P/G
Shaft coupling *	Drilling: 10 mm	GS 10
	Drilling: 6 mm	GS 06
Clamp disc *	4 pcs. / AWC	SP 15
Clamp ring *	2 pcs. / AWC	SP H
Reducing adapter ** (Blind shaft)	15 mm to 12 mm	RR12
	15 mm to 11 mm	RR11
	15 mm to 10 mm	RR10
	15 mm to 8 mm	RR8
Reducing adapter ** (Continuous hollow shaft)	12 mm to 11 mm	RRT11
	12 mm to 10 mm	RRT10
	12 mm to 8 mm	RRT8

* not for hollow shaft

** only for hollow shaft, in stainless steel available too

We do not assume responsibility for technical inaccuracies or omissions. Specifications are subject to change without notice.