

TRIMMER POTENTIOMETER SPECIFICATIONS

半固定規格書

編號 NO. : F-TRIMMER-01-207

型號名稱 Model Name : F-637V

DATE: 2003 年 06 月 10 日

Total Resistance 全阻抗值	_____	
Total Resistance Tolerance 全阻抗容許誤差值	±30%	
Resistance Taper 阻抗特性型式	Linear B	
Rated Power 負載功率	0.1W	
Residual Resistance 殘留阻抗值	5% max. of nominal value	
Total Rotation Angle 全回轉角度	200 ±20% min.	
Rotation Torque 旋轉力矩	40 ~ 250 gf.cm	
Rotation Stopper Strength 旋轉止動強度	0.5 Kgf.cm Min.	
Temperature characteristics 溫度特性	+5 % /-30% max. 5 hours /70 of the normal resistance	
Load life 負載壽命	±5 % max. 3 hours rated load	
Load life in humidity 負載耐濕性	20% max. 350 hours rated load in 90%R.H. 40	
Mechanical Strength 機械強度	Bakelite base not be broken down adding force on 1 kg min	
Max.. soldering-iron temp and allowable time 最高焊錫溫度與允許焊錫時間	250 for 2 seconds.	
Durability Rotational Life 耐久次數值	±5% max. for 100 rotations	
核 準 Approved	審 查 Q.I.Department	經 辦 者 Design Dept
		屈 艷 飛

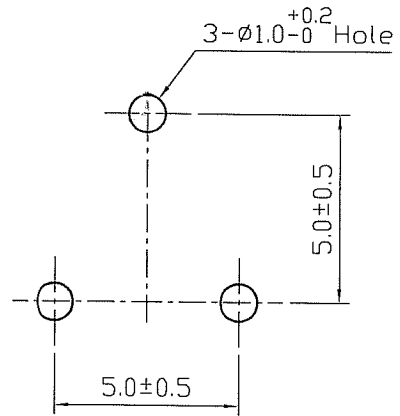
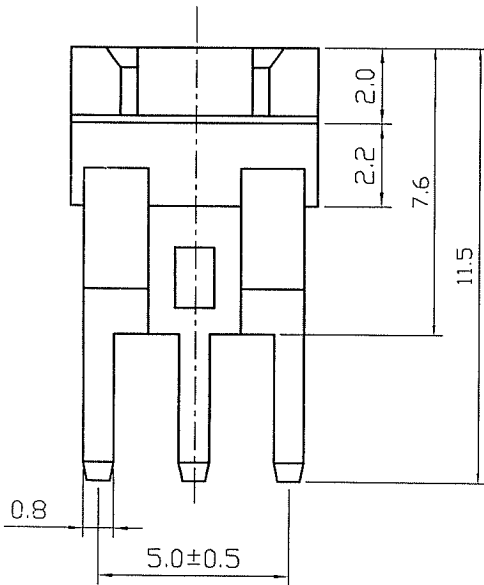
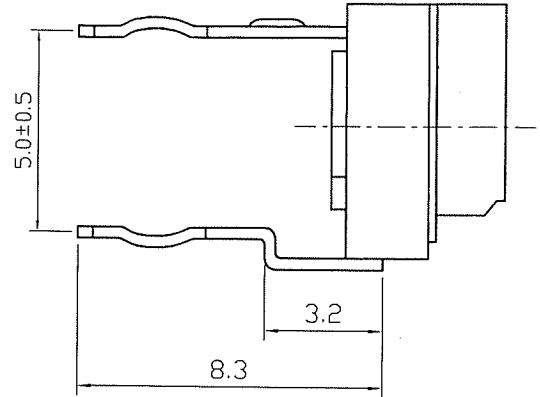
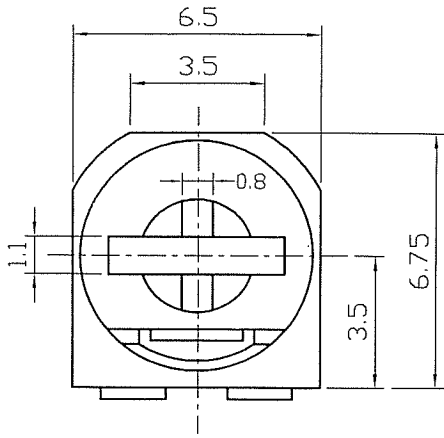

未指定容許± 尺寸之公差	
10以下	± 0.3
10~100	± 0.5
100以上	± 0.8
角 度	± 5°

MTL		SPEC		DISPOSAL			
△				UNIT	SCALE	TITLE	
△				MM	5 / 1	F-TRIMMER Series	
△				DRAWN	DESIGN	CHECK	APPROVAL
				李東			
DE				99.12.13			
						DWG NAME	
						F-637V (TR)	
						DWG NO.	
						F-TRIMMER-TR-044	

