

# BC640; BCP53; BCX53

80 V, 1 A PNP medium power transistors

Rev. 06 — 13 March 2006

Product data sheet

## 1. Product profile

### 1.1 General description

PNP medium power transistor series.

Table 1: Product overview

Type number [1]	Package			NPN complement
	Philips	JEITA	JEDEC	
BC640 [2]	SOT54	SC-43A	TO-92	BC639
BCP53	SOT223	SC-73	-	BCP56
BCX53	SOT89	SC-62	TO-243	BCX56

[1] Valid for all available selection groups.

[2] Also available in SOT54A and SOT54 variant packages (see [Section 2](#)).

### 1.2 Features

- High current
- Two current gain selections

### 1.3 Applications

- Linear voltage regulators
- Low side switches
- Supply line switches
- MOSFET drivers

### 1.4 Quick reference data

Table 2: Quick reference data

Symbol	Parameter	Conditions	Min	Typ	Max	Unit
$V_{CE0}$	collector-emitter voltage	open base	-	-	-80	V
$I_C$	collector current		-	-	-1	A
$I_{CM}$	peak collector current	single pulse; $t_p \leq 1$ ms	-	-	-1.5	A
$h_{FE}$	DC current gain	$V_{CE} = -2$ V; $I_C = -150$ mA	63	-	250	
	$h_{FE}$ selection -10	$V_{CE} = -2$ V; $I_C = -150$ mA	63	-	160	
	$h_{FE}$ selection -16	$V_{CE} = -2$ V; $I_C = -150$ mA	100	-	250	

**PHILIPS**

**2. Pinning information**

**Table 3: Pinning**

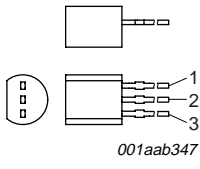
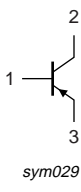
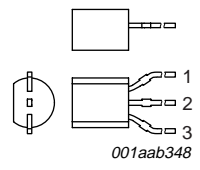
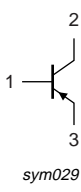
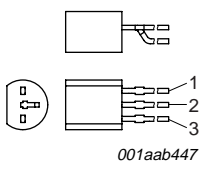
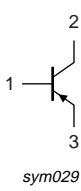
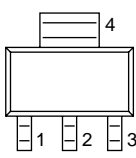
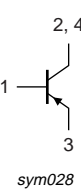
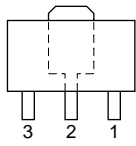
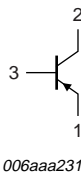
Pin	Description	Simplified outline	Symbol
<b>SOT54</b>			
1	base		
2	collector		
3	emitter		
<b>SOT54A</b>			
1	base		
2	collector		
3	emitter		
<b>SOT54 variant</b>			
1	base		
2	collector		
3	emitter		
<b>SOT223</b>			
1	base		
2	collector		
3	emitter		
4	collector		
<b>SOT89</b>			
1	emitter		
2	collector		
3	base		

### 3. Ordering information

Table 4: Ordering information

Type number <sup>[1]</sup>	Package		
	Name	Description	Version
BC640 <sup>[2]</sup>	SC-43A	plastic single-ended leaded (through hole) package; 3 leads	SOT54
BCP53	SC-73	plastic surface mounted package with increased heatsink; 4 leads	SOT223
BCX53	SC-62	plastic surface mounted package; collector pad for good heat transfer; 3 leads	SOT89

[1] Valid for all available selection groups.

[2] Also available in SOT54A and SOT54 variant packages (see [Section 2](#) and [Section 9](#)).

### 4. Marking

Table 5: Marking codes

Type number	Marking code
BC640	C640
BC640-16	C64016
BCP53	BCP53
BCP53-10	BCP53/10
BCP53-16	BCP53/16
BCX53	AH
BCX53-10	AK
BCX53-16	AL

## 5. Limiting values

**Table 6: Limiting values**

*In accordance with the Absolute Maximum Rating System (IEC 60134).*

Symbol	Parameter	Conditions	Min	Max	Unit	
$V_{CBO}$	collector-base voltage	open emitter	-	-100	V	
$V_{CEO}$	collector-emitter voltage	open base	-	-80	V	
$V_{EBO}$	emitter-base voltage	open collector	-	-5	V	
$I_C$	collector current		-	-1	A	
$I_{CM}$	peak collector current	single pulse; $t_p \leq 1$ ms	-	-1.5	A	
$I_{BM}$	peak base current	single pulse; $t_p \leq 1$ ms	-	-0.2	A	
$P_{tot}$	total power dissipation	$T_{amb} \leq 25$ °C				
			BC640	[1] -	0.83	W
			BCP53	[1] -	0.65	W
				[2] -	1	W
			BCX53	[1] -	0.5	W
				[2] -	0.9	W
[3] -	1.5	W				
$T_{stg}$	storage temperature		-65	+150	°C	
$T_j$	junction temperature		-	150	°C	
$T_{amb}$	ambient temperature		-65	+150	°C	

[1] Device mounted on an FR4 Printed-Circuit Board (PCB), single-sided copper, tin-plated and standard footprint.

[2] Device mounted on an FR4 PCB, single-sided copper, tin-plated, mounting pad for collector 1 cm<sup>2</sup>.

[3] Device mounted on an FR4 PCB, single-sided copper, tin-plated, mounting pad for collector 6 cm<sup>2</sup>.

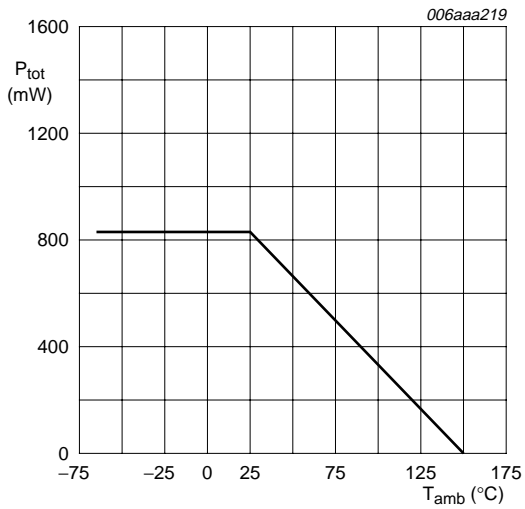

FR4 PCB; standard footprint

**Fig 1. Power derating curve SOT54**

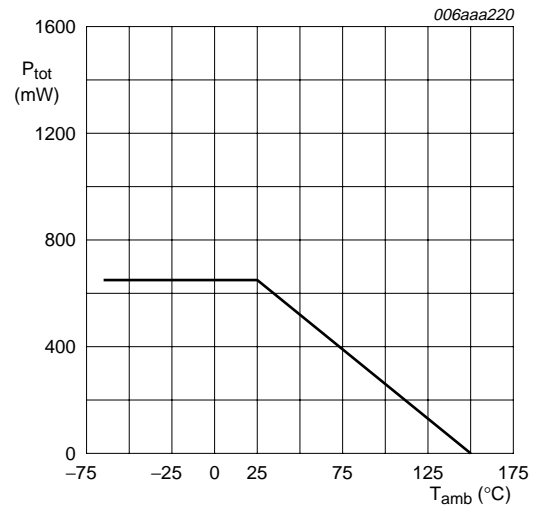

FR4 PCB; standard footprint

**Fig 2. Power derating curve SOT223**

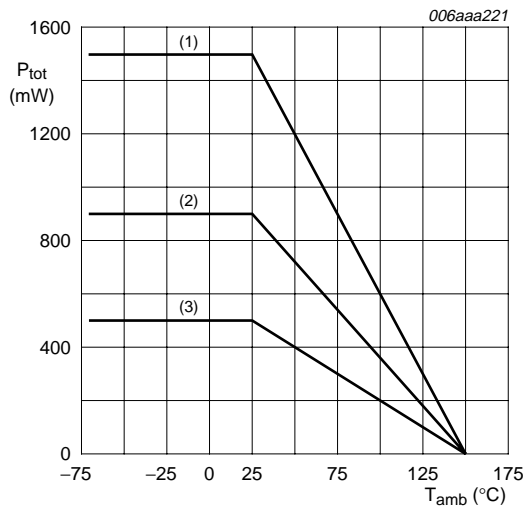

- (1) FR4 PCB; mounting pad for collector 6 cm<sup>2</sup>
- (2) FR4 PCB; mounting pad for collector 1 cm<sup>2</sup>
- (3) FR4 PCB; standard footprint

**Fig 3. Power derating curves SOT89**

## 6. Thermal characteristics

**Table 7: Thermal characteristics**

Symbol	Parameter	Conditions	Min	Typ	Max	Unit		
$R_{th(j-a)}$	thermal resistance from junction to ambient	in free air						
			BC640	[1]	-	-	150	K/W
			BCP53	[1]	-	-	190	K/W
				[2]	-	-	125	K/W
			BCX53	[1]	-	-	230	K/W
				[2]	-	-	135	K/W
[3]	-	-		85	K/W			
$R_{th(j-sp)}$	thermal resistance from junction to solder point							
		BC640		-	-	40	K/W	
		BCP53		-	-	17	K/W	
		BCX53		-	-	20	K/W	

[1] Device mounted on an FR4 PCB, single-sided copper, tin-plated and standard footprint.

[2] Device mounted on an FR4 PCB, single-sided copper, tin-plated, mounting pad for collector 1 cm<sup>2</sup>.

[3] Device mounted on an FR4 PCB, single-sided copper, tin-plated, mounting pad for collector 6 cm<sup>2</sup>.

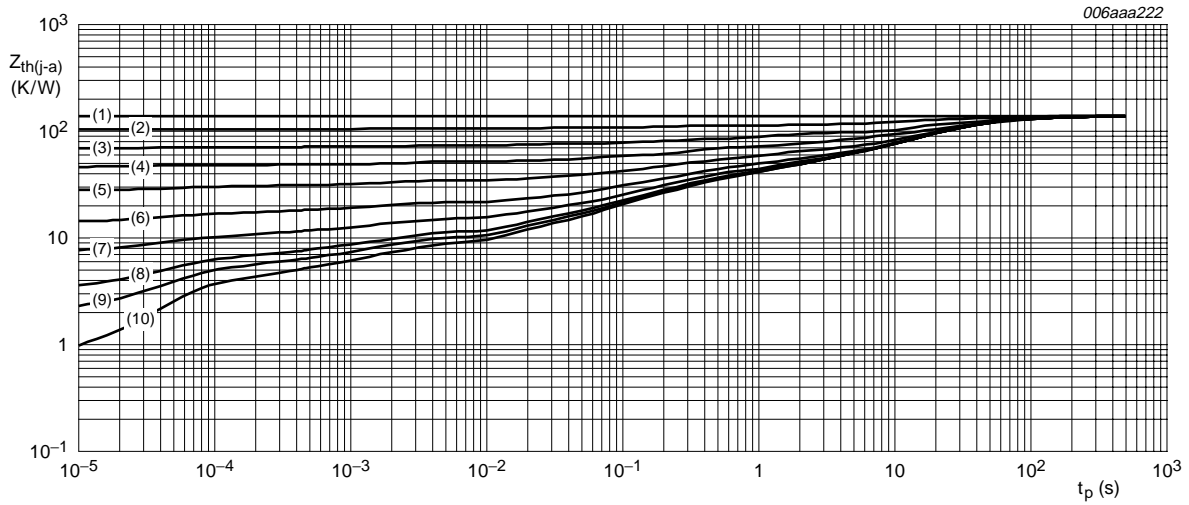

FR4 PCB; standard footprint

- (1)  $\delta = 1$
- (2)  $\delta = 0.75$
- (3)  $\delta = 0.33$
- (4)  $\delta = 0.5$
- (5)  $\delta = 0.2$
- (6)  $\delta = 0.1$
- (7)  $\delta = 0.05$
- (8)  $\delta = 0.02$
- (9)  $\delta = 0.01$
- (10)  $\delta = 0$

**Fig 4. Transient thermal impedance from junction to ambient as a function of pulse time for SOT54; typical values**

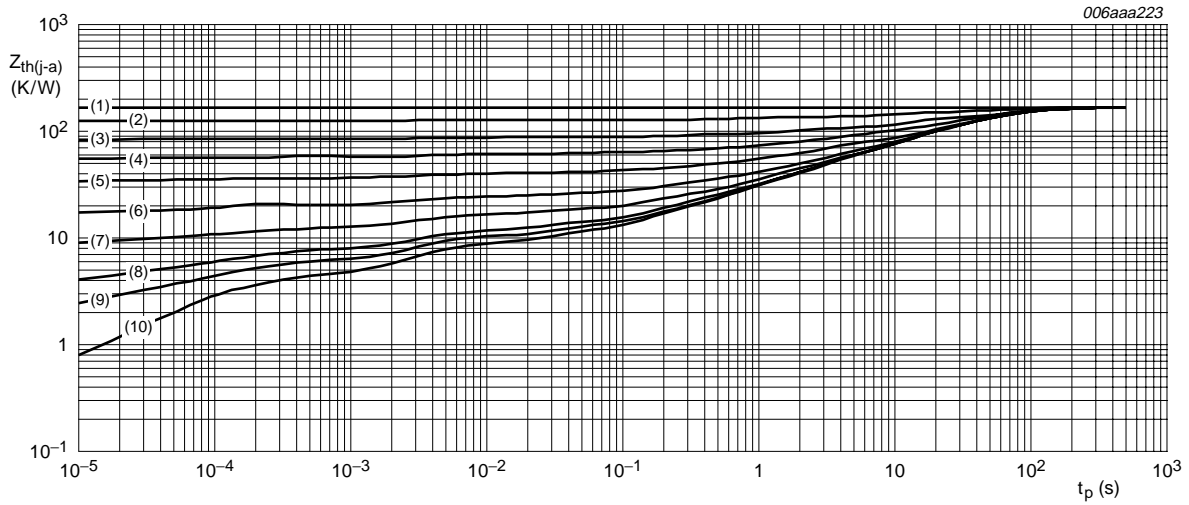

FR4 PCB; standard footprint

- (1)  $\delta = 1$
- (2)  $\delta = 0.75$
- (3)  $\delta = 0.5$
- (4)  $\delta = 0.33$
- (5)  $\delta = 0.2$
- (6)  $\delta = 0.1$
- (7)  $\delta = 0.05$
- (8)  $\delta = 0.02$
- (9)  $\delta = 0.01$
- (10)  $\delta = 0$

**Fig 5. Transient thermal impedance from junction to ambient as a function of pulse time for SOT223; typical values**

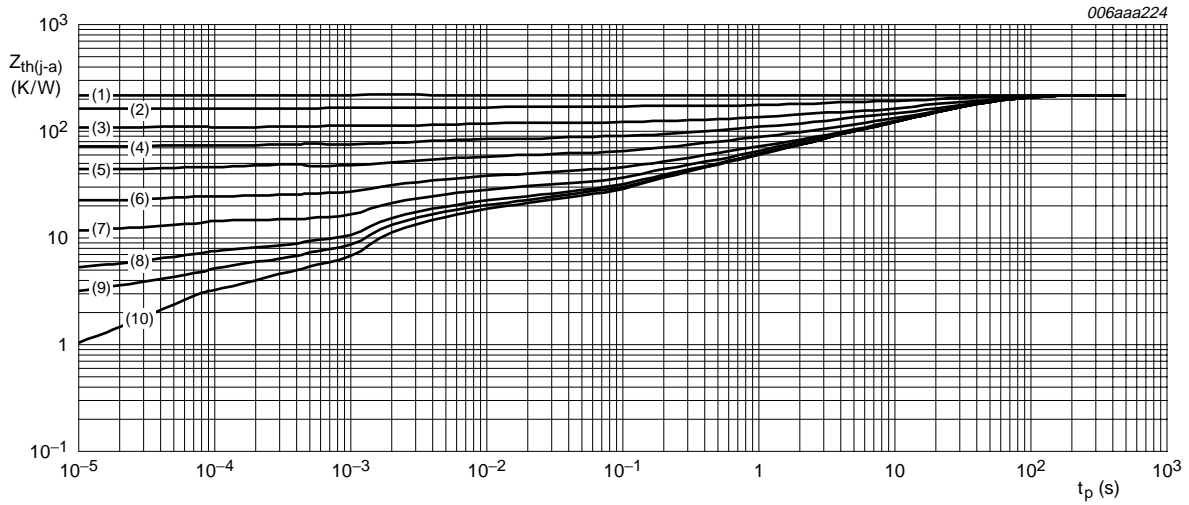

FR4 PCB; standard footprint

- (1)  $\delta = 1$
- (2)  $\delta = 0.75$
- (3)  $\delta = 0.5$
- (4)  $\delta = 0.33$
- (5)  $\delta = 0.2$
- (6)  $\delta = 0.1$
- (7)  $\delta = 0.05$
- (8)  $\delta = 0.02$
- (9)  $\delta = 0.01$
- (10)  $\delta = 0$

**Fig 6. Transient thermal impedance from junction to ambient as a function of pulse time for SOT89; typical values**

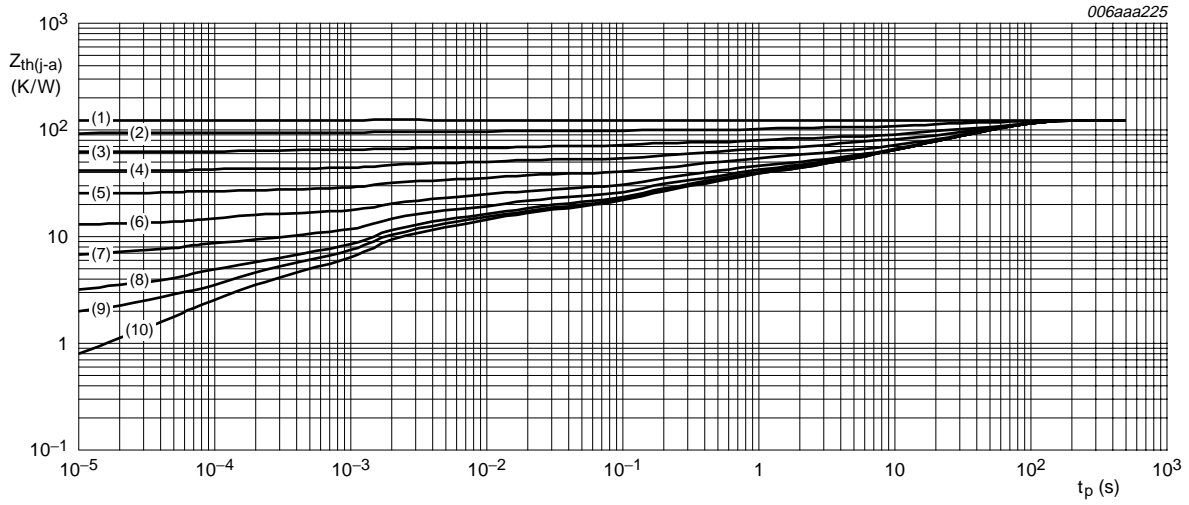

FR4 PCB; mounting pad for collector 1 cm<sup>2</sup>

- (1)  $\delta = 1$
- (2)  $\delta = 0.75$
- (3)  $\delta = 0.5$
- (4)  $\delta = 0.33$
- (5)  $\delta = 0.2$
- (6)  $\delta = 0.1$
- (7)  $\delta = 0.05$
- (8)  $\delta = 0.02$
- (9)  $\delta = 0.01$
- (10)  $\delta = 0$

**Fig 7. Transient thermal impedance from junction to ambient as a function of pulse time for SOT89; typical values**

## 7. Characteristics

**Table 8: Characteristics**

$T_{amb} = 25\text{ }^{\circ}\text{C}$  unless otherwise specified.

Symbol	Parameter	Conditions	Min	Typ	Max	Unit
$I_{CBO}$	collector-base cut-off current	$V_{CB} = -30\text{ V}; I_E = 0\text{ A}$	-	-	-100	nA
		$V_{CB} = -30\text{ V}; I_E = 0\text{ A}; T_j = 150\text{ }^{\circ}\text{C}$	-	-	-10	$\mu\text{A}$
$I_{EBO}$	emitter-base cut-off current	$V_{EB} = -5\text{ V}; I_C = 0\text{ A}$	-	-	-100	nA
$h_{FE}$	DC current gain	$V_{CE} = -2\text{ V}$				
		$I_C = -5\text{ mA}$	63	-	-	
		$I_C = -150\text{ mA}$	63	-	250	
		$I_C = -500\text{ mA}$	40	-	-	
	DC current gain	$V_{CE} = -2\text{ V}$				
	$h_{FE}$ selection -10	$I_C = -150\text{ mA}$	63	-	160	
	$h_{FE}$ selection -16	$I_C = -150\text{ mA}$	100	-	250	
$V_{CEsat}$	collector-emitter saturation voltage	$I_C = -500\text{ mA}; I_B = -50\text{ mA}$	-	-	-0.5	V
$V_{BE}$	base-emitter voltage	$I_C = -500\text{ mA}; V_{CE} = -2\text{ V}$	-	-	-1	V
$C_c$	collector capacitance	$V_{CB} = -15\text{ V}; I_E = i_e = 0\text{ A}; f = 1\text{ MHz}$	-	15	-	pF
$f_T$	transition frequency	$V_{CE} = -5\text{ V}; I_C = -50\text{ mA}; f = 100\text{ MHz}$	-	145	-	MHz

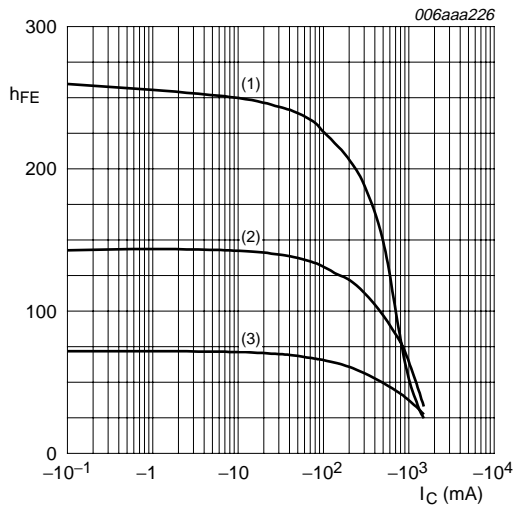

$V_{CE} = -2\text{ V}$

- (1)  $T_{amb} = 150\text{ °C}$
- (2)  $T_{amb} = 25\text{ °C}$
- (3)  $T_{amb} = -55\text{ °C}$

**Fig 8. DC current gain as a function of collector current; typical values**

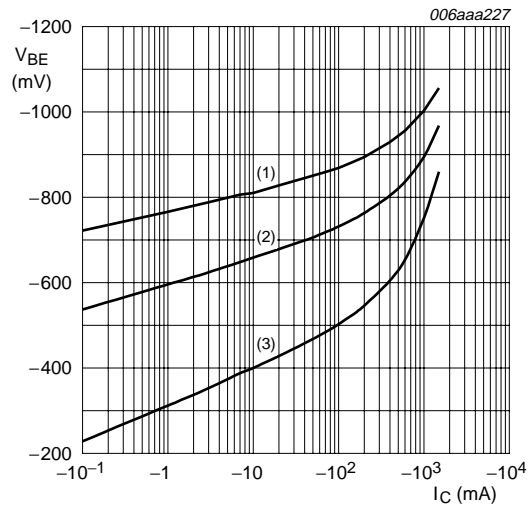

$V_{CE} = -2\text{ V}$

- (1)  $T_{amb} = -55\text{ °C}$
- (2)  $T_{amb} = 25\text{ °C}$
- (3)  $T_{amb} = 150\text{ °C}$

**Fig 9. Base-emitter voltage as a function of collector current; typical values**

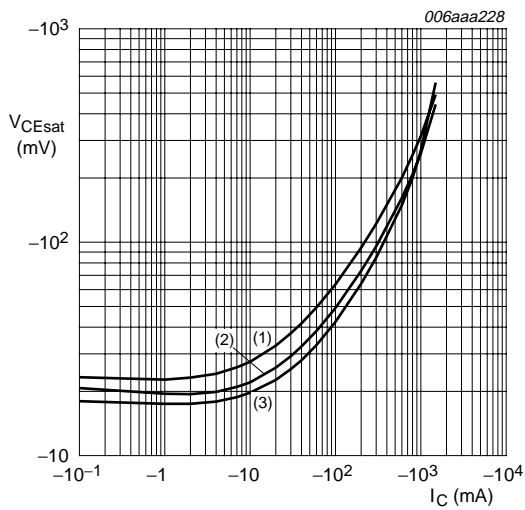

$I_C/I_B = 10$

- (1)  $T_{amb} = 150\text{ °C}$
- (2)  $T_{amb} = 25\text{ °C}$
- (3)  $T_{amb} = -55\text{ °C}$

**Fig 10. Collector-emitter saturation voltage as a function of collector current; typical values**

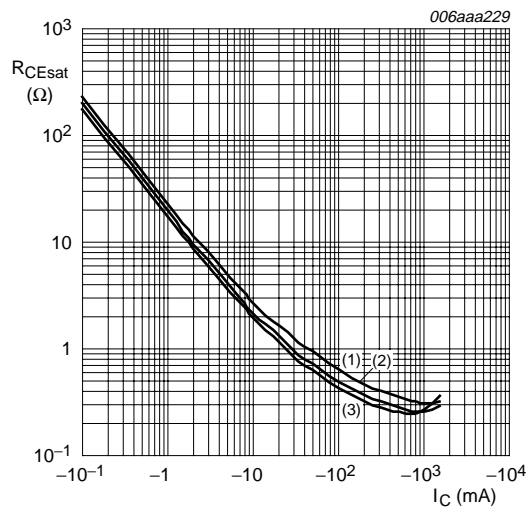

$I_C/I_B = 10$

- (1)  $T_{amb} = 150\text{ °C}$
- (2)  $T_{amb} = 25\text{ °C}$
- (3)  $T_{amb} = -55\text{ °C}$

**Fig 11. Collector-emitter saturation resistance as a function of collector current; typical values**

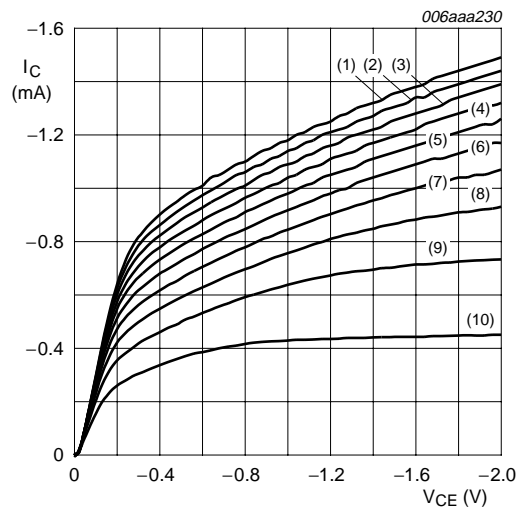

$T_{amb} = 25\text{ }^{\circ}\text{C}$

- (1)  $I_B = -45\text{ mA}$
- (2)  $I_B = -40.5\text{ mA}$
- (3)  $I_B = -36\text{ mA}$
- (4)  $I_B = -31.5\text{ mA}$
- (5)  $I_B = -27\text{ mA}$
- (6)  $I_B = -22.5\text{ mA}$
- (7)  $I_B = -18\text{ mA}$
- (8)  $I_B = -13.5\text{ mA}$
- (9)  $I_B = -9\text{ mA}$
- (10)  $I_B = -4.5\text{ mA}$

**Fig 12. Collector current as a function of collector-emitter voltage; typical values**

**8. Package outline**

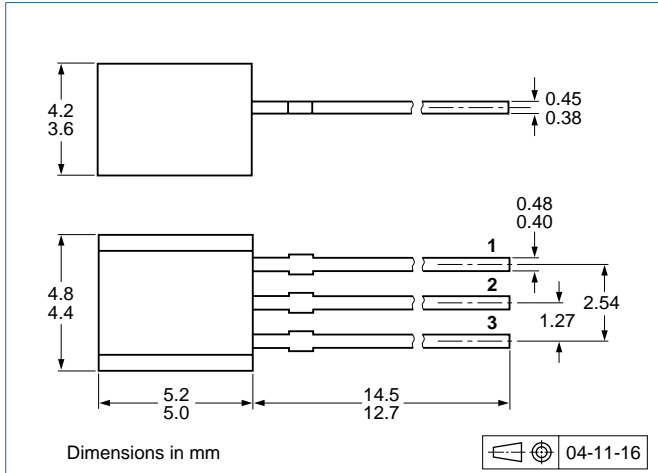

**Fig 13. Package outline SOT54 (SC-43A/TO-92)**

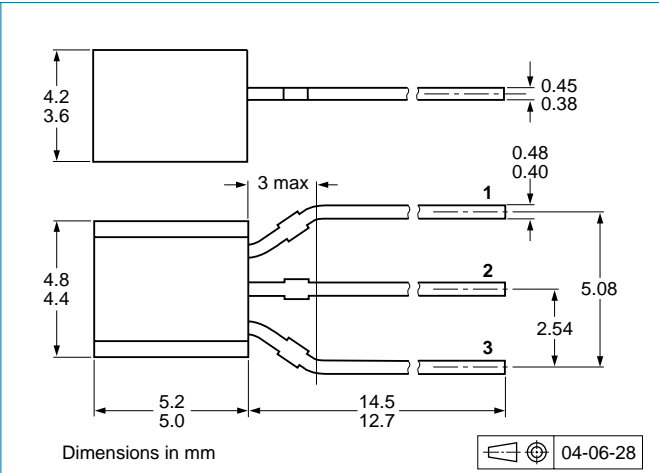

**Fig 14. Package outline SOT54A**

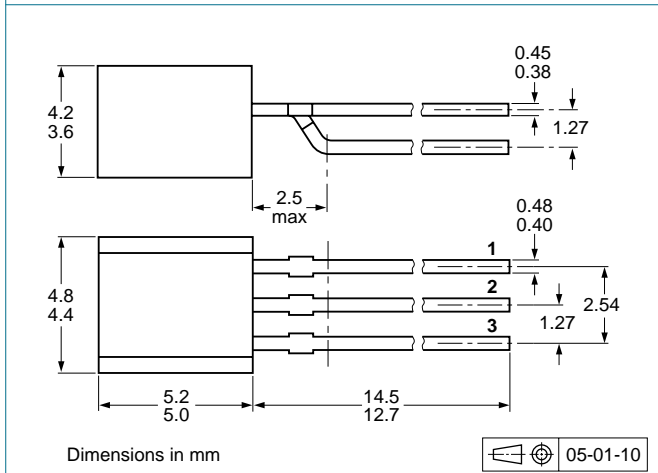

**Fig 15. Package outline SOT54 variant**

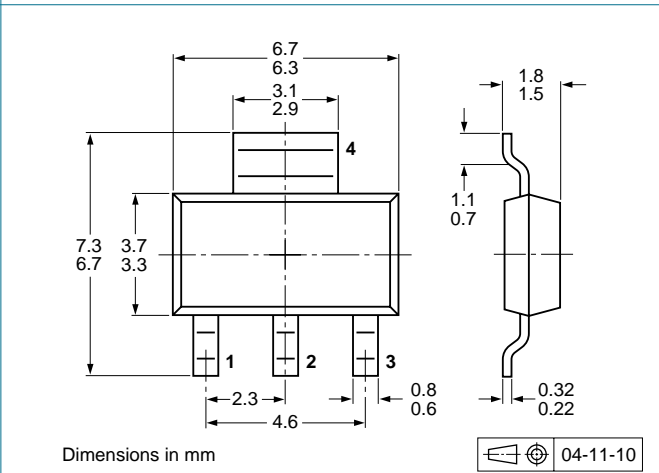

**Fig 16. Package outline SOT223 (SC-73)**

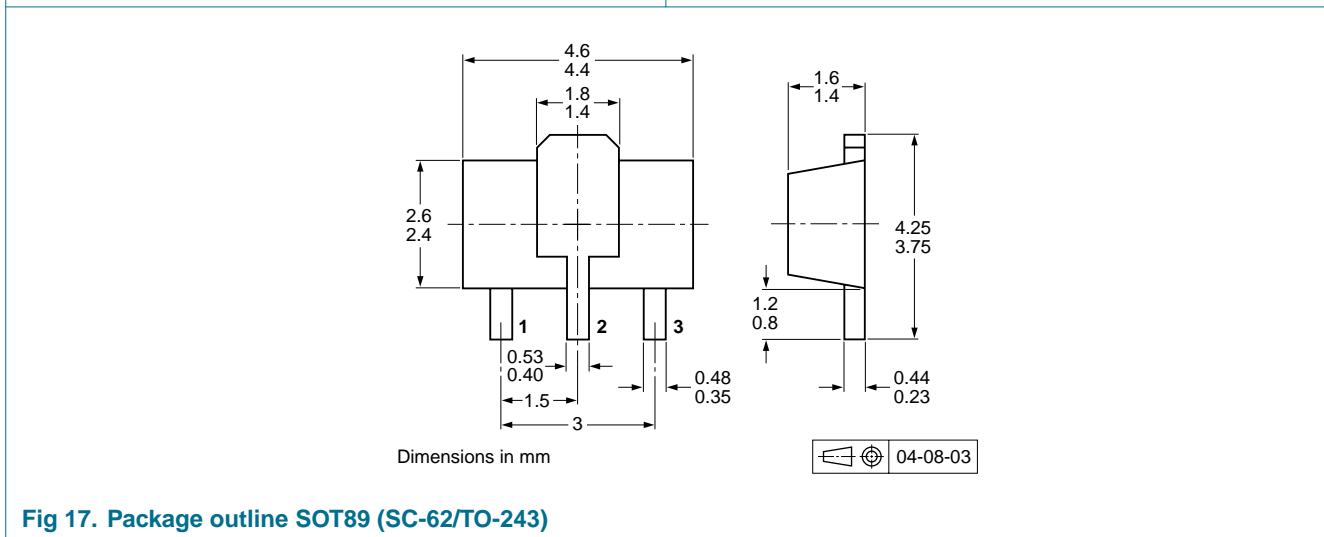

**Fig 17. Package outline SOT89 (SC-62/TO-243)**

## 9. Packing information

**Table 9: Packing methods**

The indicated -xxx are the last three digits of the 12NC ordering code. [\[1\]](#)

Type number <a href="#">[2]</a>	Package	Description	Packing quantity			
			1000	4000	5000	10000
BC640	SOT54	bulk, straight leads	-	-	-412	-
	SOT54A	tape and reel, wide pitch	-	-	-	-116
		tape ammpack, wide pitch	-	-	-	-126
BC640	SOT54 variant	bulk, delta pinning	-	-	-112	-
BCP53	SOT223	4 mm pitch, 12 mm tape and reel	-115	-135	-	-
BCX53	SOT89	8 mm pitch, 12 mm tape and reel	-115	-135	-	-

[1] For further information and the availability of packing methods, see [Section 15](#).

[2] Valid for all available selection groups.

## 10. Revision history

Table 10: Revision history

Document ID	Release date	Data sheet status	Change notice	Doc. number	Supersedes
BC640_BCP53_BCX53_6	20060313	Product data sheet	-	9397 750 14045	BC636_638_640_5 BCP51_52_53_5 BCX51_52_53_4
Modifications: <ul style="list-style-type: none"> <li>• The format of this data sheet has been redesigned to comply with the new presentation and information standard of Philips Semiconductors.</li> <li>• This data sheet contains a type combination out of the previous data sheets BC636_638_640_5, BCP51_52_53_5 and BCX51_52_53_4.</li> <li>• <a href="#">Table 1 "Product overview"</a>: added</li> <li>• <a href="#">Figure 1, 2 and 3</a>: added</li> <li>• <a href="#">Table 7</a>: amended typing error for BCP53 maximum value on 1 cm<sup>2</sup> footprint condition</li> <li>• <a href="#">Figure 4, 5, 6 and 7</a>: added</li> <li>• <a href="#">Figure 8</a>: amended</li> <li>• <a href="#">Figure 9, 10, 11 and 12</a>: added</li> <li>• <a href="#">Figure 14 and 15</a>: added</li> <li>• <a href="#">Figure 13, 16 and 17</a>: superseded by minimized package outline drawings</li> <li>• <a href="#">Section 9 "Packing information"</a>: added</li> <li>• <a href="#">Section 14 "Trademarks"</a>: added</li> </ul>					
BC636_638_640_5	20041011	Product specification	-	9397 750 13575	BC636_638_640_4
BCP51_52_53_5	20030206	Product specification	-	9397 750 10764	BCP51_52_53_4
BCX51_52_53_4	20011010	Product specification	-	9397 750 08743	BCX51_52_53_3

## 11. Data sheet status

Level	Data sheet status <sup>[1]</sup>	Product status <sup>[2]</sup> <sup>[3]</sup>	Definition
I	Objective data	Development	This data sheet contains data from the objective specification for product development. Philips Semiconductors reserves the right to change the specification in any manner without notice.
II	Preliminary data	Qualification	This data sheet contains data from the preliminary specification. Supplementary data will be published at a later date. Philips Semiconductors reserves the right to change the specification without notice, in order to improve the design and supply the best possible product.
III	Product data	Production	This data sheet contains data from the product specification. Philips Semiconductors reserves the right to make changes at any time in order to improve the design, manufacturing and supply. Relevant changes will be communicated via a Customer Product/Process Change Notification (CPCN).

[1] Please consult the most recently issued data sheet before initiating or completing a design.

[2] The product status of the device(s) described in this data sheet may have changed since this data sheet was published. The latest information is available on the Internet at URL <http://www.semiconductors.philips.com>.

[3] For data sheets describing multiple type numbers, the highest-level product status determines the data sheet status.

## 12. Definitions

**Short-form specification** — The data in a short-form specification is extracted from a full data sheet with the same type number and title. For detailed information see the relevant data sheet or data handbook.

**Limiting values definition** — Limiting values given are in accordance with the Absolute Maximum Rating System (IEC 60134). Stress above one or more of the limiting values may cause permanent damage to the device. These are stress ratings only and operation of the device at these or at any other conditions above those given in the Characteristics sections of the specification is not implied. Exposure to limiting values for extended periods may affect device reliability.

**Application information** — Applications that are described herein for any of these products are for illustrative purposes only. Philips Semiconductors makes no representation or warranty that such applications will be suitable for the specified use without further testing or modification.

## 13. Disclaimers

**Life support** — These products are not designed for use in life support appliances, devices, or systems where malfunction of these products can reasonably be expected to result in personal injury. Philips Semiconductors

## 15. Contact information

For additional information, please visit: <http://www.semiconductors.philips.com>

For sales office addresses, send an email to: [sales.addresses@www.semiconductors.philips.com](mailto:sales.addresses@www.semiconductors.philips.com)

customers using or selling these products for use in such applications do so at their own risk and agree to fully indemnify Philips Semiconductors for any damages resulting from such application.

**Right to make changes** — Philips Semiconductors reserves the right to make changes in the products - including circuits, standard cells, and/or software - described or contained herein in order to improve design and/or performance. When the product is in full production (status 'Production'), relevant changes will be communicated via a Customer Product/Process Change Notification (CPCN). Philips Semiconductors assumes no responsibility or liability for the use of any of these products, conveys no license or title under any patent, copyright, or mask work right to these products, and makes no representations or warranties that these products are free from patent, copyright, or mask work right infringement, unless otherwise specified.

## 14. Trademarks

**Notice** — All referenced brands, product names, service names and trademarks are the property of their respective owners.

## 16. Contents

<b>1</b>	<b>Product profile</b> .....	<b>1</b>
1.1	General description .....	1
1.2	Features .....	1
1.3	Applications .....	1
1.4	Quick reference data .....	1
<b>2</b>	<b>Pinning information</b> .....	<b>2</b>
<b>3</b>	<b>Ordering information</b> .....	<b>3</b>
<b>4</b>	<b>Marking</b> .....	<b>3</b>
<b>5</b>	<b>Limiting values</b> .....	<b>4</b>
<b>6</b>	<b>Thermal characteristics</b> .....	<b>6</b>
<b>7</b>	<b>Characteristics</b> .....	<b>11</b>
<b>8</b>	<b>Package outline</b> .....	<b>14</b>
<b>9</b>	<b>Packing information</b> .....	<b>15</b>
<b>10</b>	<b>Revision history</b> .....	<b>16</b>
<b>11</b>	<b>Data sheet status</b> .....	<b>17</b>
<b>12</b>	<b>Definitions</b> .....	<b>17</b>
<b>13</b>	<b>Disclaimers</b> .....	<b>17</b>
<b>14</b>	<b>Trademarks</b> .....	<b>17</b>
<b>15</b>	<b>Contact information</b> .....	<b>17</b>



© Koninklijke Philips Electronics N.V. 2006

All rights are reserved. Reproduction in whole or in part is prohibited without the prior written consent of the copyright owner. The information presented in this document does not form part of any quotation or contract, is believed to be accurate and reliable and may be changed without notice. No liability will be accepted by the publisher for any consequence of its use. Publication thereof does not convey nor imply any license under patent- or other industrial or intellectual property rights.

Date of release: 13 March 2006  
Document number: 9397 750 14045

Published in The Netherlands