



SB520 ~ SB560

SCHOTTKY BARRIER RECTIFIERS

VOLTAGE 20 to 60 Volts **CURRENT** 5 Amperes

DO-201AD Unit: inch(mm)

FEATURES

- Plastic package has Underwriters Laboratory Flammability Classification 94V-O utilizing Flame Retardant Epoxy Molding Compound.
- Exceeds environmental standards of MIL-S-19500/228
- For use in low voltage, high frequency inverters, free wheeling, and polarity protection applications.
- In compliance with EU RoHS 2002/95/EC directives

MECHANICAL DATA

- Case: DO-201AD Molded plastic
- Terminals: Axial leads, solderable per MIL-STD-750, Method 2026
- Polarity: Color band denotes cathode
- Mounting Position: Any
- Weight: 0.039 ounces, 1.122 grams

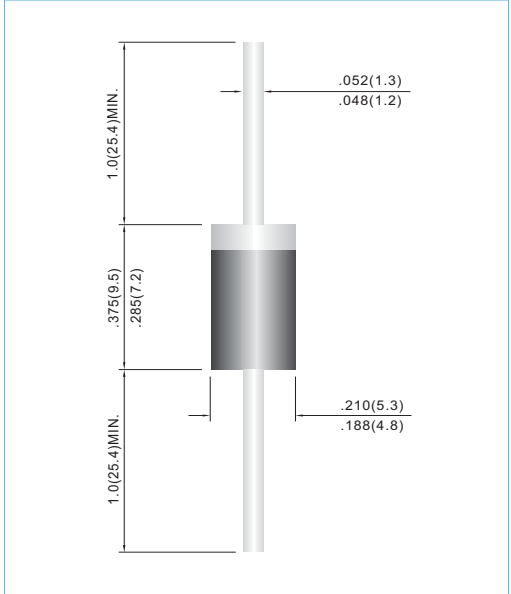

MAXIMUM RATINGS AND ELECTRICAL CHARACTERISTICS

Ratings at 25°C ambient temperature unless otherwise specified. Single phase, half wave, 60 Hz, resistive or inductive load.

PARAMETER	SYMBOL	SB520	SB530	SB540	SB550	SB560	UNITS
Maximum Recurrent Peak Reverse Voltage	V_{RRM}	20	30	40	50	60	V
Maximum RMS Voltage	V_{RMS}	14	21	28	35	42	V
Maximum DC Blocking Voltage	V_{DC}	20	30	40	50	60	V
Maximum Average Forward Rectified Current .375" (9.5mm) lead length at $T_L = 60^\circ C$	$I_{F(AV)}$	5					A
Peak Forward Surge Current : 8.3ms single half sine-wave superimposed on rated load (JEDEC method)	I_{FSM}	150					A
Maximum Forward Voltage at 5.0A	V_F	0.55		0.70		V	
Maximum DC Reverse Current $T_A = 25^\circ C$ at Rated DC Blocking Voltage $T_A = 100^\circ C$	I_R	0.2 50		0.1 50		mA	
Maximum Thermal Resistance (Note 1)	$R_{\theta_{JL}}$	15		10		$^\circ C / W$	
Operating Junction Temperature Range	T_J	-50 to +125					$^\circ C$
Storage Temperature Range	T_{STG}	-50 to +150					$^\circ C$

NOTES:

1. Thermal Resistance Junction to Lead Vertical PC Board Mounting .375" (9.5mm) Lead Lengths.



SB520 ~ SB560

RATING AND CHARACTERISTIC CURVES

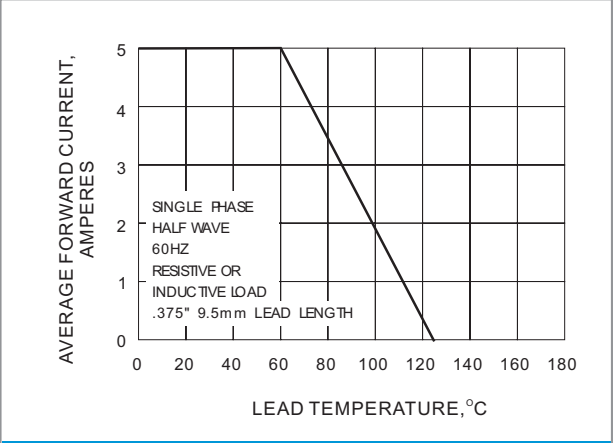

Fig. 1- FORWARD CURRENT DERATING CURVE

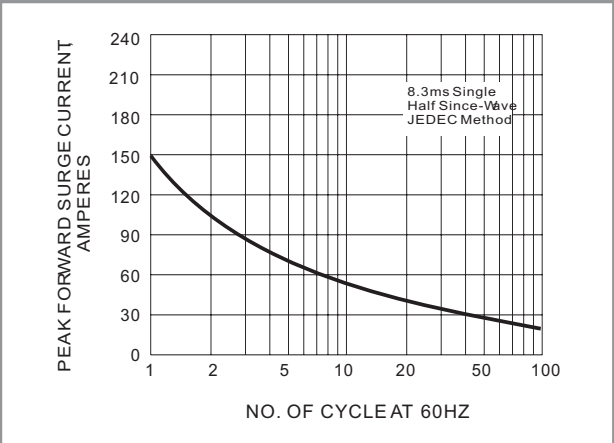

Fig. 2- TMAXIMUM NON - REPETITIVE SURGE CURRENT

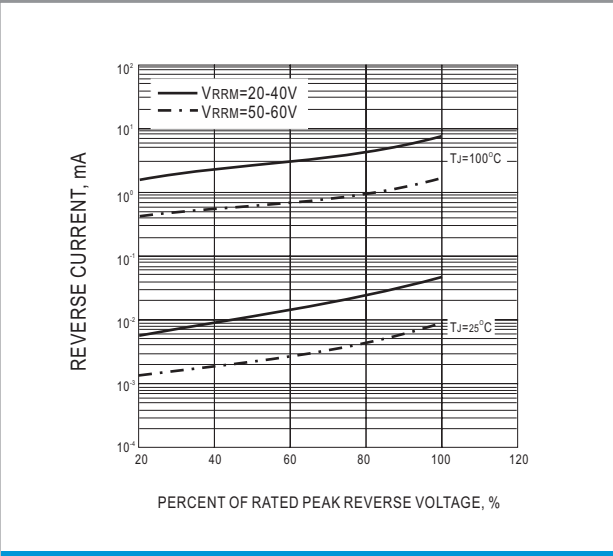

Fig. 3- TYPICAL REVERSE CHARACTERISTIC

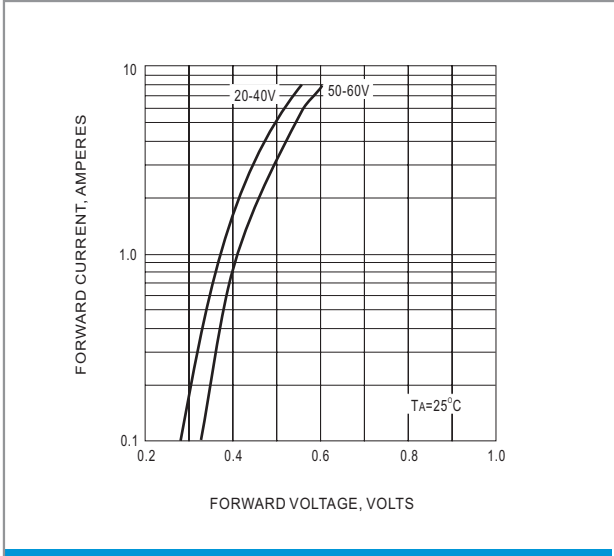

Fig. 4- TYPICAL INSTANTANEOUS FORWARD CHARACTERISTIC