

# MJD18002D2

## Bipolar NPN Transistor

### High Speed, High Gain Bipolar NPN Power Transistor with Integrated Collector–Emitter Diode and Built–In Efficient Antisaturation Network

The MJD18002D2 is a state-of-the-art high speed, high gain bipolar transistor (H2BIP). Tight dynamic characteristics and lot to lot minimum spread ( $\pm 150$  ns on storage time) make it ideally suitable for light ballast applications. Therefore, there is no longer a need to guarantee an  $h_{FE}$  window.

#### Main Features:

- Low Base Drive Requirement
- High Peak DC Current Gain (55 Typical) @  $I_C = 100$  mA
- **Extremely Low Storage Time Min/Max Guarantees Due to the H2BIP Structure which Minimizes the Spread**
- Integrated Collector–Emitter Free Wheeling Diode
- Fully Characterized and Guaranteed Dynamic  $V_{CEsat}$
- Characteristics Make It Suitable for PFC Application
- “6 Sigma” Process Providing Tight and Reproducible Parameter Spreads

#### Two Versions:

- MJD18002D2–1: Case 369 for Insertion Mode
- MJD18002D2: Case 369A for Surface Mount Mode

#### MAXIMUM RATINGS

Rating	Symbol	Value	Unit
Collector–Emitter Sustaining Voltage	$V_{CEO}$	450	Vdc
Collector–Base Breakdown Voltage	$V_{CBO}$	1000	Vdc
Collector–Emitter Breakdown Voltage	$V_{CES}$	1000	Vdc
Emitter–Base Voltage	$V_{EBO}$	11	Vdc
Collector Current – Continuous – Peak (Note 1.)	$I_C$ $I_{CM}$	2.0 5.0	Adc
Base Current – Continuous – Peak (Note 1.)	$I_B$ $I_{BM}$	1.0 2.0	Adc

#### THERMAL CHARACTERISTICS

Characteristic	Symbol	Value	Unit
Total Device Dissipation @ $T_C = 25^\circ\text{C}$ Derate above $25^\circ\text{C}$	$P_D$	50 0.4	W W/ $^\circ\text{C}$
Operating and Storage Temperature Range	$T_J, T_{stg}$	–65 to +150	$^\circ\text{C}$
Thermal Resistance – Junction–to–Case	$R_{\theta JC}$	5.0	$^\circ\text{C}/\text{W}$
Thermal Resistance – Junction–to–Ambient	$R_{\theta JA}$	71.4	$^\circ\text{C}/\text{W}$
Maximum Lead Temperature for Soldering Purposes: 1/8" from Case for 5 sec.	$T_L$	260	$^\circ\text{C}$

1. Pulse Test: Pulse Width = 5.0 ms, Duty Cycle = 10%



ON Semiconductor™

<http://onsemi.com>

**2 AMPERES  
1000 VOLTS  
50 WATTS  
POWER TRANSISTOR**

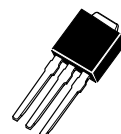
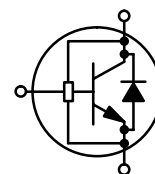

DPAK  
CASE 369  
STYLE 1



DPAK  
CASE 369A  
STYLE 1

#### MARKING DIAGRAMS

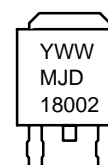
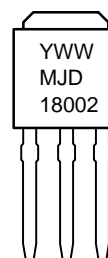

Y = Year  
WW = Work Week  
MJD18002 = Device Code

#### ORDERING INFORMATION

Device	Package	Shipping
MJD18002D2–1	DPAK	75 Units/Rail
MJD18002D2T4	DPAK	3000/Tape & Reel

# MJD18002D2

## ELECTRICAL CHARACTERISTICS ( $T_C = 25^\circ\text{C}$ unless otherwise noted)

Characteristic	Symbol	Min	Typ	Max	Unit
----------------	--------	-----	-----	-----	------

### OFF CHARACTERISTICS

Collector–Emitter Sustaining Voltage ( $I_C = 100\text{ mA}$ , $L = 25\text{ mH}$ )	$V_{CEO(sus)}$	450	570	–	Vdc
Collector–Base Breakdown Voltage ( $I_{CBO} = 1\text{ mA}$ )	$V_{CBO}$	1000	1100	–	Vdc
Emitter–Base Breakdown Voltage ( $I_{EBO} = 1\text{ mA}$ )	$V_{EBO}$	11	14	–	Vdc
Collector Cutoff Current ( $V_{CE} = \text{Rated } V_{CEO}$ , $I_B = 0$ )	$I_{CEO}$	–	–	100	$\mu\text{A}$ dc
Collector Cutoff Current ( $V_{CE} = \text{Rated } V_{CES}$ , $V_{EB} = 0$ )  ( $V_{CE} = 500\text{ V}$ , $V_{EB} = 0$ )	@ $T_C = 25^\circ\text{C}$	–	–	100	$\mu\text{A}$ dc
	@ $T_C = 125^\circ\text{C}$	–	–	500	
	@ $T_C = 125^\circ\text{C}$	–	–	100	
Emitter–Cutoff Current ( $V_{EB} = 10\text{ Vdc}$ , $I_C = 0$ )	$I_{EBO}$	–	–	500	$\mu\text{A}$ dc

### ON CHARACTERISTICS

Base–Emitter Saturation Voltage ( $I_C = 0.4\text{ Adc}$ , $I_B = 40\text{ mA}$ dc) ( $I_C = 1.0\text{ Adc}$ , $I_B = 0.2\text{ Adc}$ )	@ $T_C = 25^\circ\text{C}$	$V_{BE(sat)}$	–	0.78	1.0	Vdc
	@ $T_C = 125^\circ\text{C}$		–	0.87	1.1	
Collector–Emitter Saturation Voltage ( $I_C = 0.4\text{ Adc}$ , $I_B = 40\text{ mA}$ dc)  ( $I_C = 1.0\text{ Adc}$ , $I_B = 0.2\text{ Adc}$ )	@ $T_C = 25^\circ\text{C}$	$V_{CE(sat)}$	–	0.36	0.6	Vdc
	@ $T_C = 125^\circ\text{C}$		–	0.50	1.0	
	@ $T_C = 25^\circ\text{C}$	–	0.40	0.75		
	@ $T_C = 125^\circ\text{C}$	–	0.65	1.2		
DC Current Gain ( $I_C = 0.4\text{ Adc}$ , $V_{CE} = 1.0\text{ Vdc}$ )  ( $I_C = 1.0\text{ Adc}$ , $V_{CE} = 1.0\text{ Vdc}$ )	@ $T_C = 25^\circ\text{C}$	$h_{FE}$	14	25	–	–
	@ $T_C = 125^\circ\text{C}$		8.0	15	–	
	@ $T_C = 25^\circ\text{C}$	6.0	10	–		
	@ $T_C = 125^\circ\text{C}$	4.0	6.0	–		

### DYNAMIC CHARACTERISTICS

Current Gain Bandwidth ( $I_C = 0.5\text{ Adc}$ , $V_{CE} = 10\text{ Vdc}$ , $f = 1\text{ MHz}$ )	$f_t$	–	13	–	MHz
Output Capacitance ( $V_{CB} = 10\text{ Vdc}$ , $I_E = 0$ , $f = 1\text{ MHz}$ )	$C_{ob}$	–	50	100	pF
Input Capacitance ( $V_{EB} = 8\text{ Vdc}$ )	$C_{ib}$	–	340	500	pF

### DIODE CHARACTERISTICS

Forward Diode Voltage ( $I_{EC} = 1.0\text{ Adc}$ )  ( $I_{EC} = 0.4\text{ Adc}$ )	@ $T_C = 25^\circ\text{C}$	$V_{EC}$	–	1.2	1.5	Vdc
	@ $T_C = 25^\circ\text{C}$		–	1.0	1.3	
	@ $T_C = 125^\circ\text{C}$		–	0.6	–	
Forward Recovery Time ( $I_F = 0.4\text{ Adc}$ , $di/dt = 10\text{ A}/\mu\text{s}$ )  ( $I_F = 1.0\text{ Adc}$ , $di/dt = 10\text{ A}/\mu\text{s}$ )	@ $T_C = 25^\circ\text{C}$	$t_{fr}$	–	517	–	ns
	@ $T_C = 25^\circ\text{C}$		–	480	–	

# MJD18002D2

## ELECTRICAL CHARACTERISTICS ( $T_C = 25^\circ\text{C}$ unless otherwise noted)

Characteristic	Symbol	Min	Typ	Max	Unit
----------------	--------	-----	-----	-----	------

### DYNAMIC SATURATION VOLTAGE

Dynamic Saturation Voltage Determined 1 $\mu\text{s}$ and 3 $\mu\text{s}$ respectively after rising $I_{B1}$ reaches 90% of final $I_{B1}$	$I_C = 0.4 \text{ Adc}$ $I_{B1} = 40 \text{ mA}$ $V_{CC} = 300 \text{ Vdc}$	@ 1 $\mu\text{s}$	@ $T_C = 25^\circ\text{C}$	$V_{CE(dsat)}$	–	7.4	–	V
		@ 3 $\mu\text{s}$	@ $T_C = 25^\circ\text{C}$		–	2.5	–	
	$I_C = 1 \text{ Adc}$ $I_{B1} = 0.2 \text{ A}$ $V_{CC} = 300 \text{ Vdc}$	@ 1 $\mu\text{s}$	@ $T_C = 25^\circ\text{C}$		–	11.7	–	
		@ 3 $\mu\text{s}$	@ $T_C = 25^\circ\text{C}$		–	1.3	–	

### SWITCHING CHARACTERISTICS: Resistive Load (D.C.S. 10%, Pulse Width = 40 $\mu\text{s}$ )

Turn-on Time	$I_C = 0.4 \text{ Adc}$ , $I_{B1} = 40 \text{ mAdc}$ $I_{B2} = 200 \text{ mAdc}$ $V_{CC} = 300 \text{ Vdc}$	@ $T_C = 25^\circ\text{C}$	$t_{on}$	–	225	350	ns
Turn-off Time		@ $T_C = 125^\circ\text{C}$	$t_{off}$	0.8	–	1.1	$\mu\text{s}$
Turn-on Time	$I_C = 1.0 \text{ Adc}$ , $I_{B1} = 0.2 \text{ Adc}$ $I_{B2} = 0.5 \text{ Adc}$ $V_{CC} = 300 \text{ Vdc}$	@ $T_C = 25^\circ\text{C}$	$t_{on}$	–	100	150	ns
Turn-off Time		@ $T_C = 125^\circ\text{C}$	$t_{off}$	0.95	–	1.25	$\mu\text{s}$

### SWITCHING CHARACTERISTICS: Inductive Load ( $V_{clamp} = 300 \text{ V}$ , $V_{CC} = 15 \text{ V}$ , $L = 200 \mu\text{H}$ )

Fall Time	$I_C = 0.4 \text{ Adc}$ $I_{B1} = 40 \text{ mAdc}$ $I_{B2} = 0.2 \text{ Adc}$	@ $T_C = 25^\circ\text{C}$	$t_f$	–	130	175	ns
Storage Time		@ $T_C = 125^\circ\text{C}$	$t_s$	0.4	–	0.7	$\mu\text{s}$
Cross-over Time		@ $T_C = 25^\circ\text{C}$	$t_c$	–	110	175	ns
		@ $T_C = 125^\circ\text{C}$		–	100	–	
Fall Time	$I_C = 0.8 \text{ Adc}$ $I_{B1} = 160 \text{ mAdc}$ $I_{B2} = 160 \text{ mAdc}$	@ $T_C = 25^\circ\text{C}$	$t_f$	–	130	175	ns
Storage Time		@ $T_C = 125^\circ\text{C}$	$t_s$	2.1	–	2.4	$\mu\text{s}$
Cross-over Time		@ $T_C = 25^\circ\text{C}$	$t_c$	–	275	350	ns
		@ $T_C = 125^\circ\text{C}$		–	350	–	
Fall Time	$I_C = 1.0 \text{ Adc}$ $I_{B1} = 0.2 \text{ Adc}$ $I_{B2} = 0.5 \text{ Adc}$	@ $T_C = 25^\circ\text{C}$	$t_f$	–	100	150	ns
Storage Time		@ $T_C = 125^\circ\text{C}$	$t_s$	–	1.05	1.2	$\mu\text{s}$
Cross-over Time		@ $T_C = 25^\circ\text{C}$	$t_c$	–	100	150	ns
		@ $T_C = 125^\circ\text{C}$		–	115	–	

Typical Static Characteristics

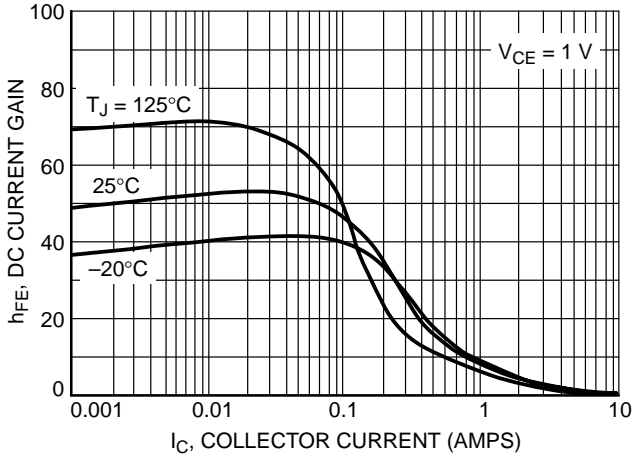

Figure 1. DC Current Gain @ 1 V

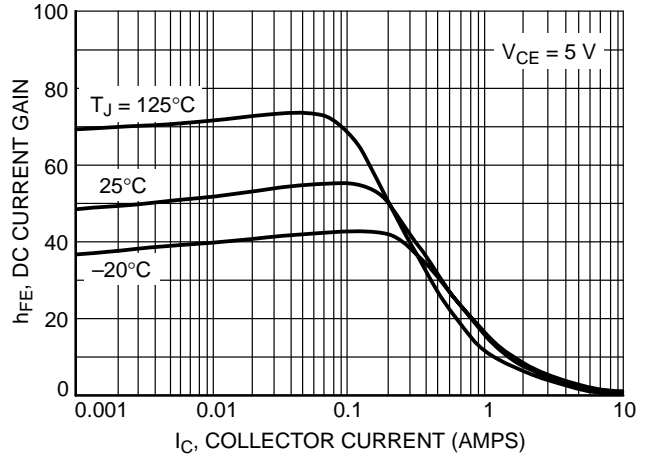

Figure 2. DC Current Gain @ 5 V

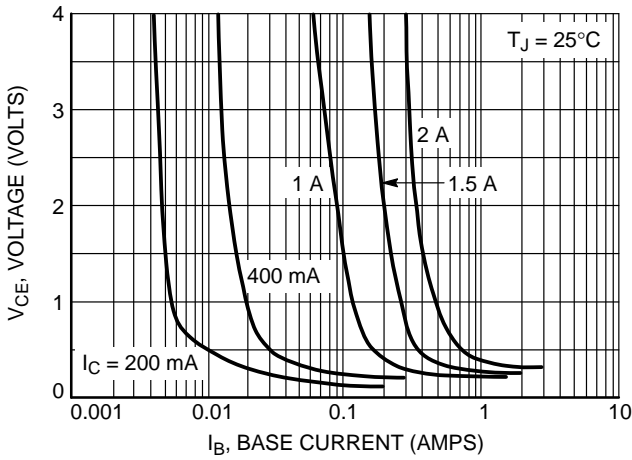

Figure 3. Collector Saturation Region

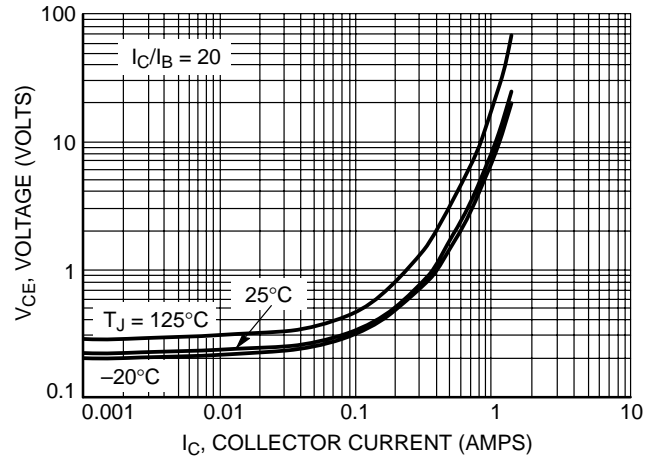

Figure 4. Collector-Emitter Saturation Voltage

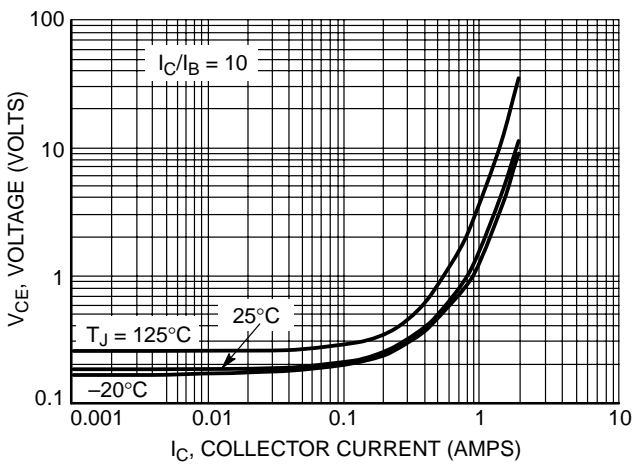

Figure 5. Collector-Emitter Saturation Voltage

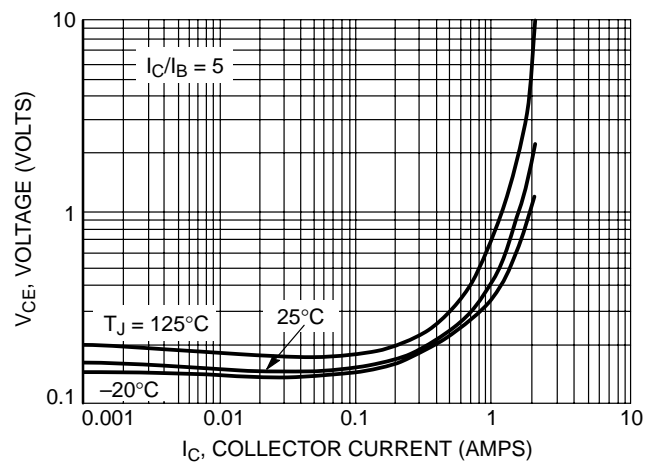

Figure 6. Collector-Emitter Saturation Voltage

Typical Static Characteristics

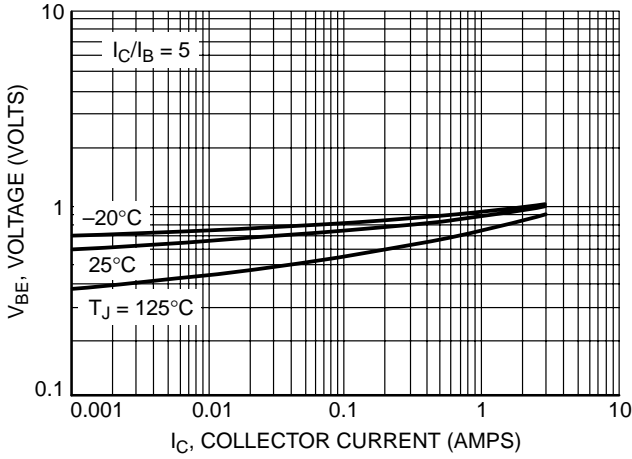

Figure 7. Base-Emitter Saturation Region  
 $I_C/I_B = 5$

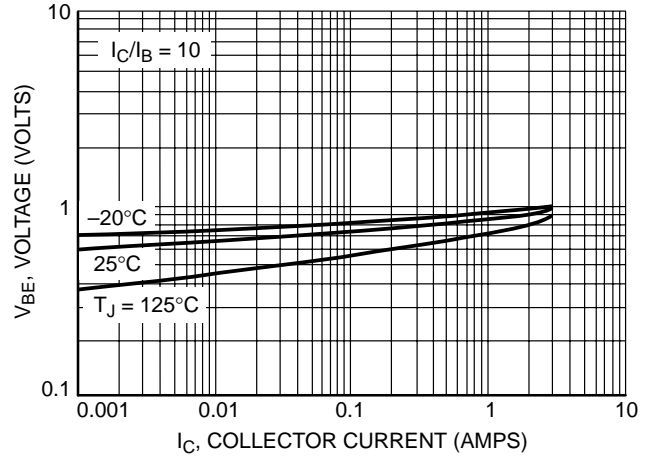

Figure 8. Base-Emitter Saturation Region  
 $I_C/I_B = 10$

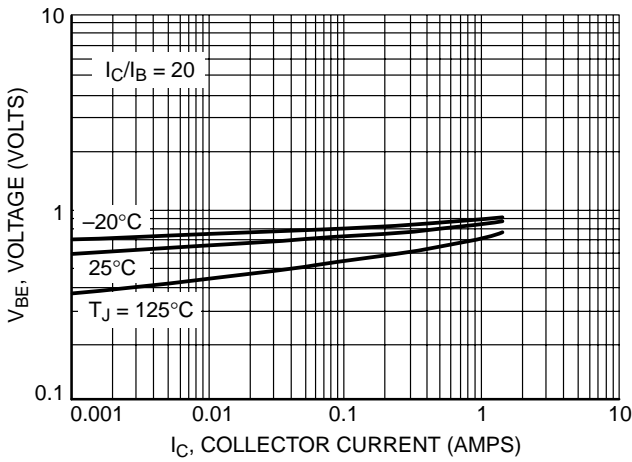

Figure 9. Base-Emitter Saturation Region  
 $I_C/I_B = 20$

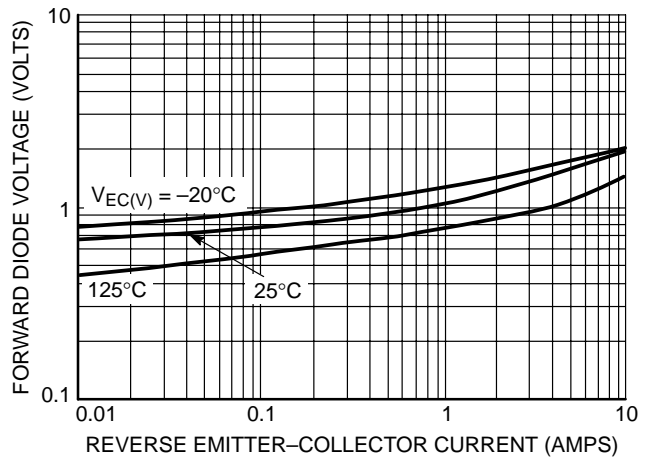

Figure 10. Forward Diode Voltage

Typical Switching Characteristics

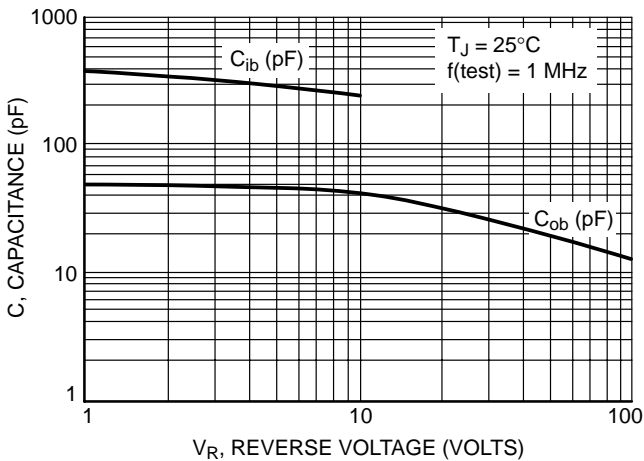

Figure 11. Capacitance

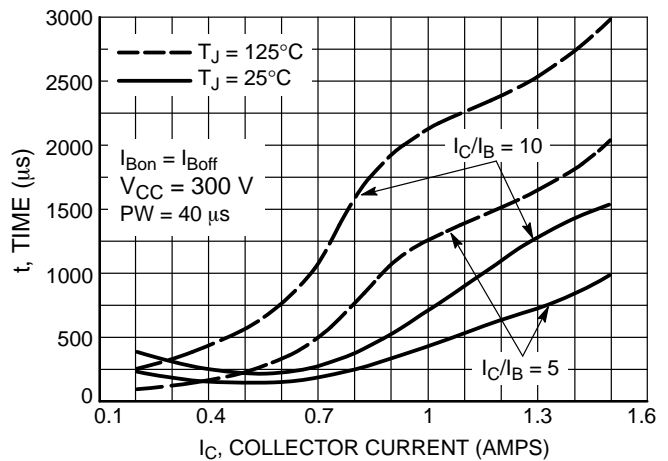

Figure 12. Resistive Switch Time,  $t_{on}$

Typical Switching Characteristics

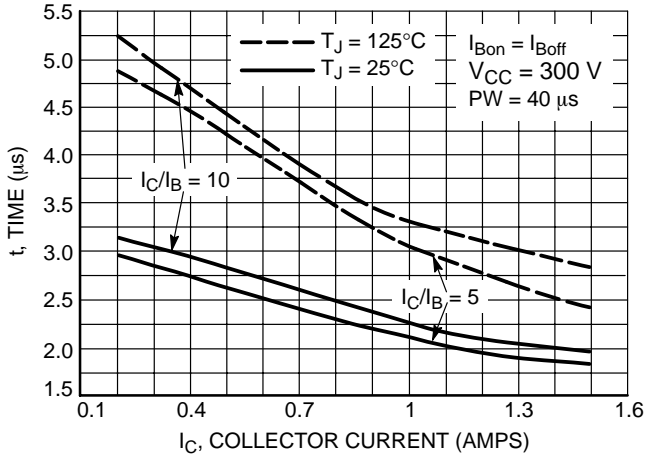

Figure 13. Resistive Switch Time,  $t_{off}$

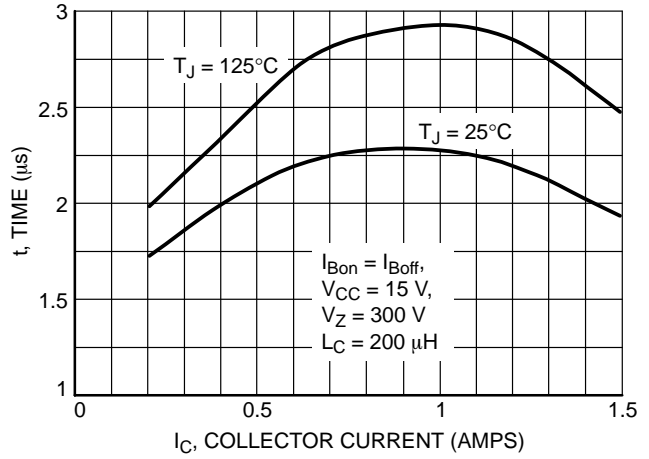

Figure 14. Inductive Storage Time,  $t_{si}$  @  $I_C/I_B = 5$

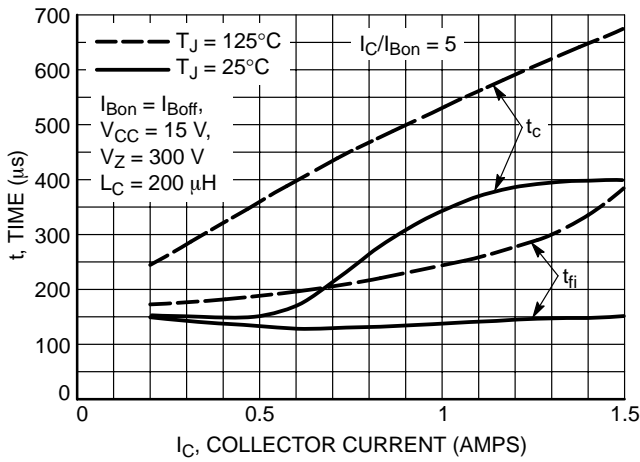

Figure 15. Inductive Switching,  $t_c$  &  $t_{fi}$  @  $I_C/I_B = 5$

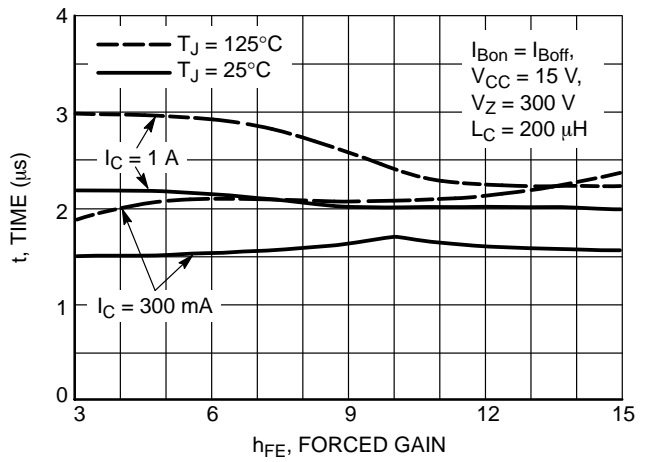

Figure 16. Inductive Storage Time

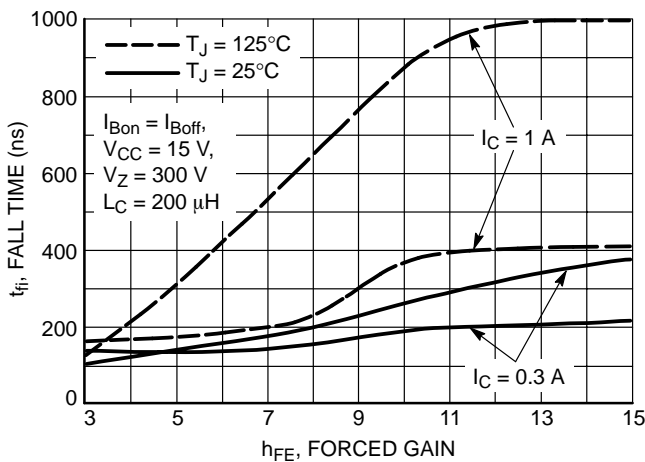

Figure 17. Inductive Fall Time

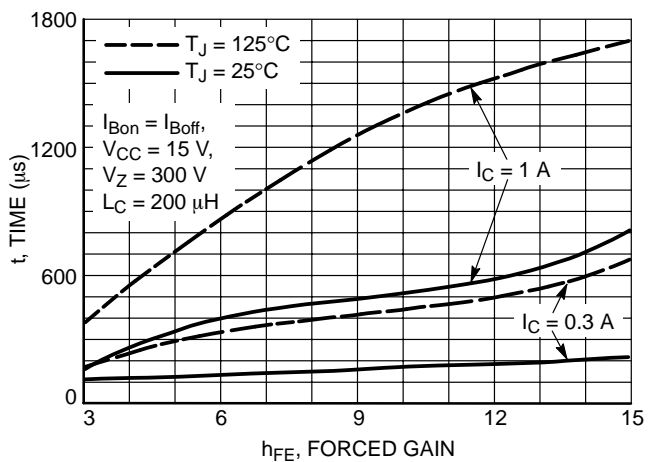

Figure 18. Inductive Cross-Over Time

Typical Switching Characteristics

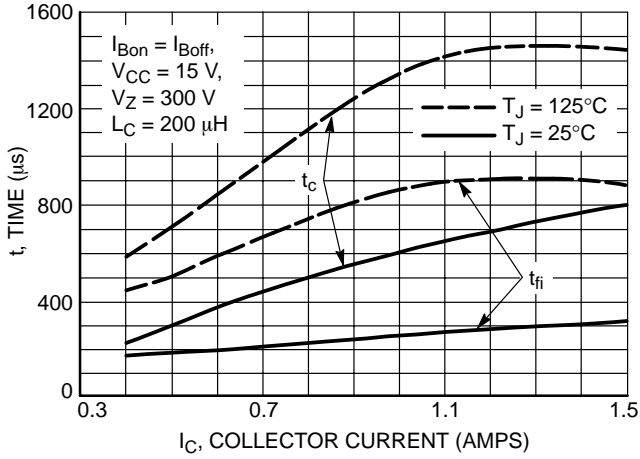

Figure 19. Inductive Switching Time,  $t_{fi}$  &  $T_C$  @  $G = 10$

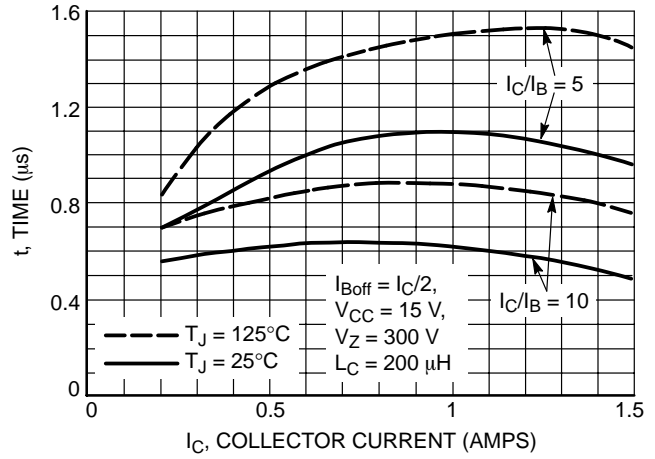

Figure 20. Inductive Switching Time,  $t_{si}$

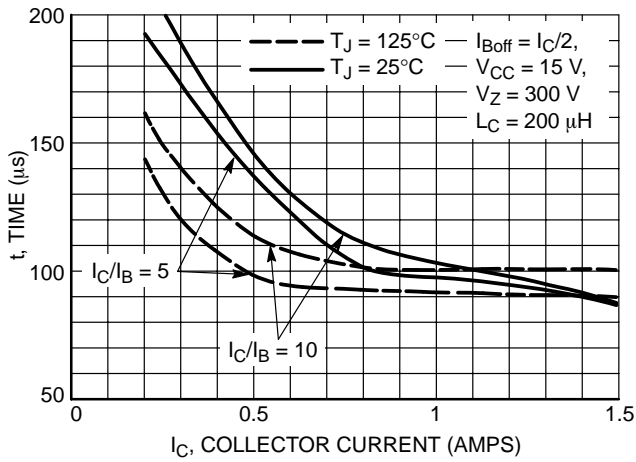

Figure 21. Inductive Storage Time,  $t_{fi}$

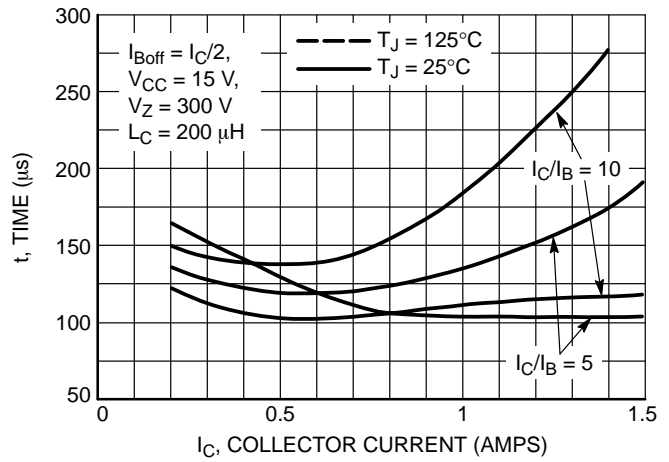

Figure 22. Inductive Storage Time,  $t_c$

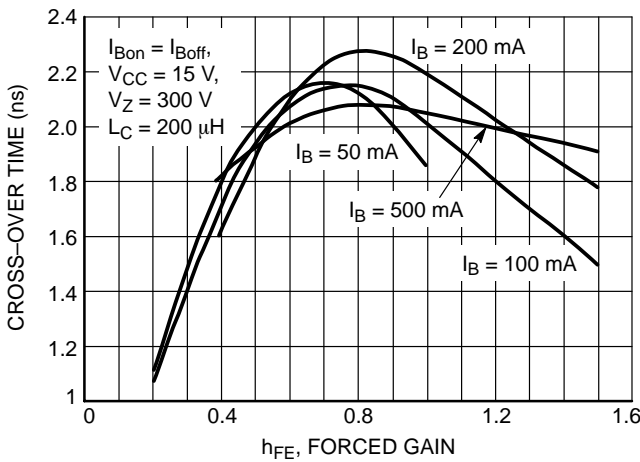

Figure 23. Inductive Storage Time,  $t_{si}$

Figure 24. Dynamic Saturation Voltage Measurements

# MJD18002D2

## Typical Switching Characteristics

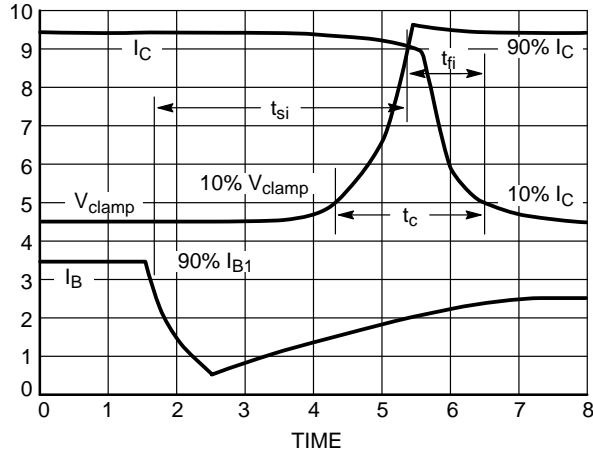
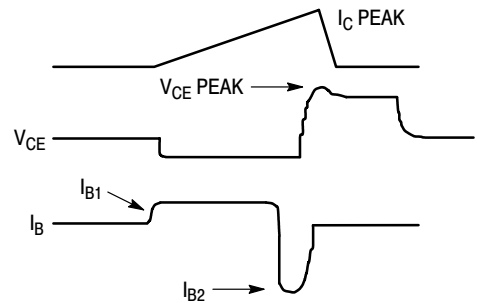
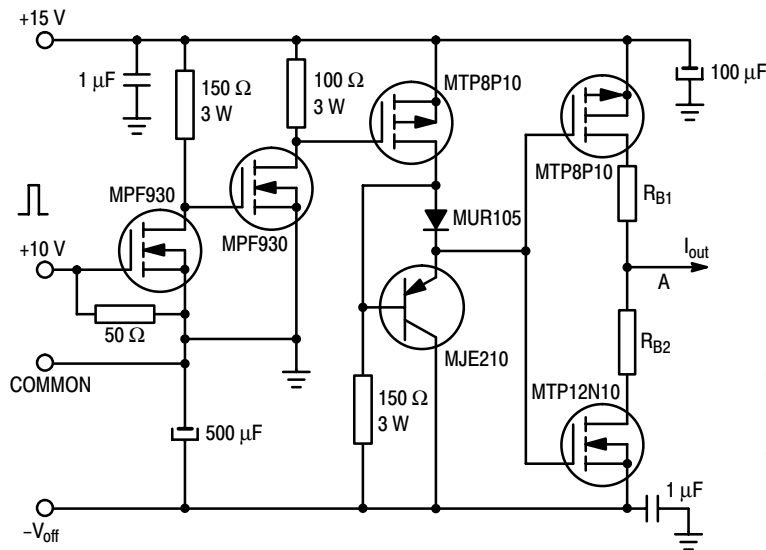

Figure 25. Inductive Switching Measurements

Table 1. Inductive Load Switching Drive Circuit



$V_{(BR)CEO(sus)}$   
 $L = 10 \text{ mH}$   
 $R_{B2} = \infty$   
 $V_{CC} = 20 \text{ Volts}$   
 $I_{C(pk)} = 100 \text{ mA}$

**Inductive Switching**  
 $L = 200 \mu\text{H}$   
 $R_{B2} = 0$   
 $V_{CC} = 15 \text{ Volts}$   
 $R_{B1}$  selected for desired  $I_{B1}$

**RBSOA**  
 $L = 500 \mu\text{H}$   
 $R_{B2} = 0$   
 $V_{CC} = 15 \text{ Volts}$   
 $R_{B1}$  selected for desired  $I_{B1}$

# MJD18002D2

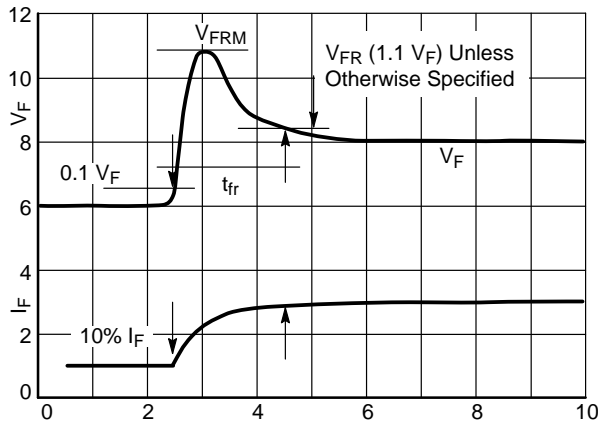

Figure 26.  $t_{fr}$  Measurement

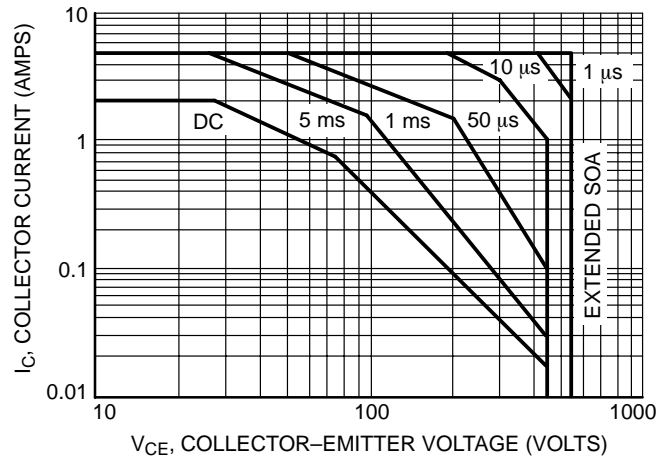

Figure 27. Forward Bias Safe Operating Area

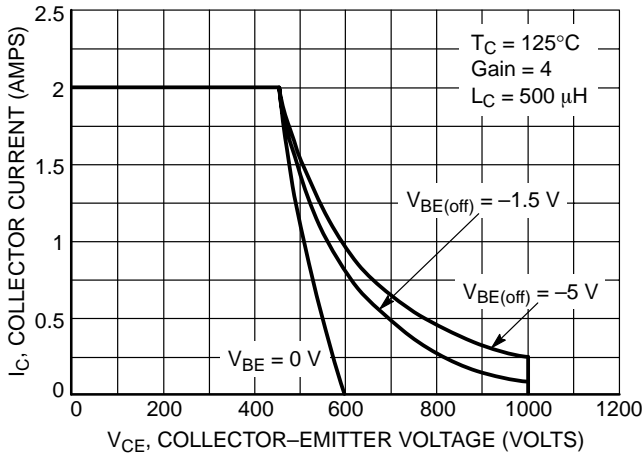

Figure 28. Reverse Bias Safe Operating Area

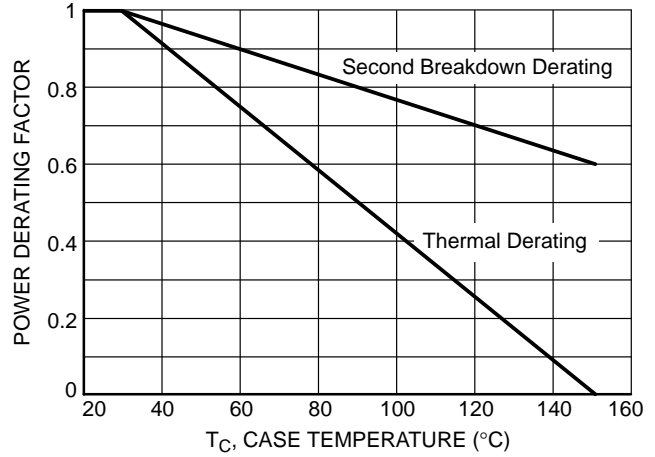

Figure 29. Forward Bias Power Derating

There are two limitations on the power handling ability of a transistor: average junction temperature and second breakdown. Safe operating area curves indicate  $I_C$ - $V_{CE}$  limits of the transistor that must be observed for reliable operation; i.e., the transistor must not be subjected to greater dissipation than the curves indicate. The data of Figure 27 is based on  $T_C = 25^\circ\text{C}$ ;  $T_{J(pk)}$  is variable depending on power level. Second breakdown pulse limits are valid for duty cycles to 10% but must be derated when  $T_C > 25^\circ\text{C}$ . Second Breakdown limitations do not derate the same as thermal limitations. Allowable current at the voltages shown on

Figure 27 may be found at any case temperature by using the appropriate curve on Figure 29.

$T_{J(pk)}$  may be calculated from the data in Figure 30. At any case temperatures, thermal limitations will reduce the power that can be handled to values less than the limitations imposed by second breakdown. For inductive loads, high voltage and current must be sustained simultaneously during turn-off with the base to emitter junction reverse biased. The safe level is specified as a reverse biased safe operating area (Figure 28). This rating is verified under clamped conditions so that the device is never subjected to an avalanche mode.

# MJD18002D2

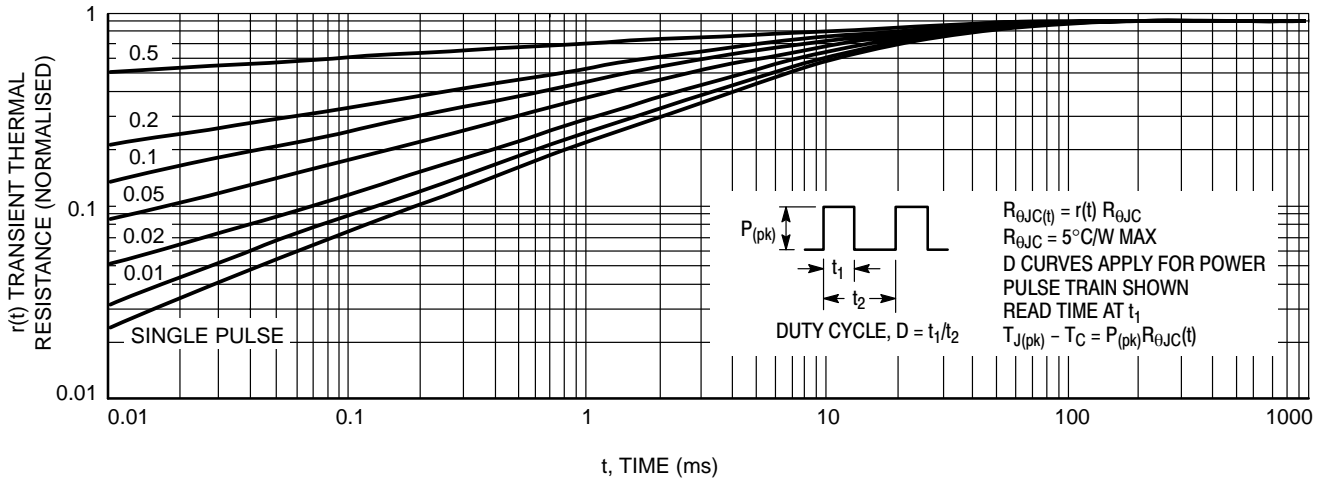

Figure 30. Typical Thermal Response ( $Z_{\theta JC}(t)$ ) for MJD18002D2

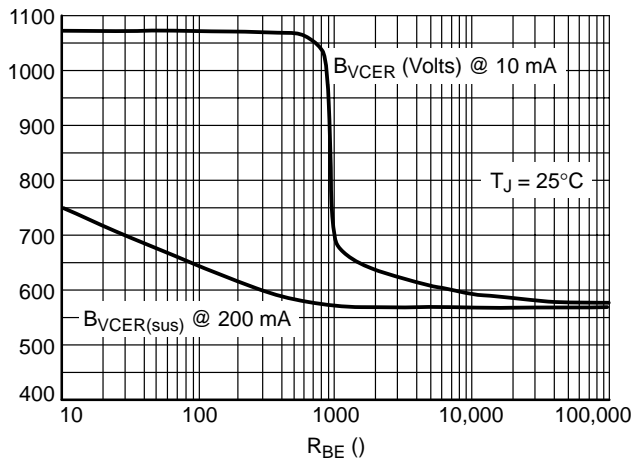

Figure 31.  $B_{VCER}$

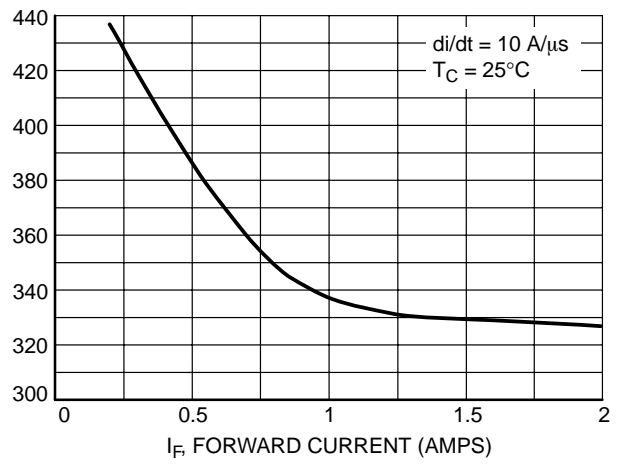
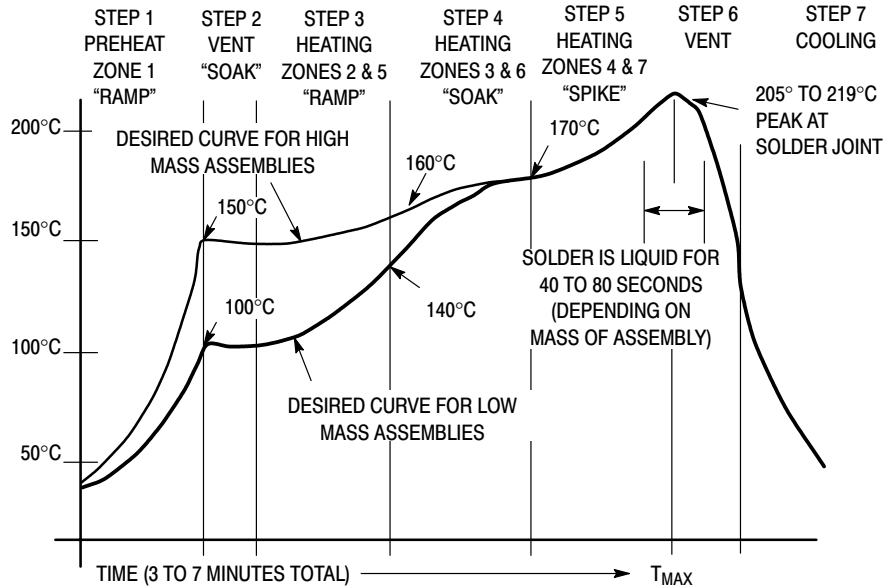

Figure 32. Forward Recovery Time,  $t_{fr}$

**TYPICAL SOLDER HEATING PROFILE**

For any given circuit board, there will be a group of control settings that will give the desired heat pattern. The operator must set temperatures for several heating zones, and a figure for belt speed. Taken together, these control settings make up a heating “profile” for that particular circuit board. On machines controlled by a computer, the computer remembers these profiles from one operating session to the next. Figure 33 shows a typical heating profile for use when soldering a surface mount device to a printed circuit board. This profile will vary among soldering systems but it is a good starting point. Factors that can affect the profile include the type of soldering system in use, density and types of components on the board, type of solder used, and the type of board or substrate material being used. This profile shows temperature versus time.

The line on the graph shows the actual temperature that might be experienced on the surface of a test board at or near a central solder joint. The two profiles are based on a high density and a low density board. The Vitronics SMD310 convection/infrared reflow soldering system was used to generate this profile. The type of solder used was 62/36/2 Tin Lead Silver with a melting point between 177–189°C. When this type of furnace is used for solder reflow work, the circuit boards and solder joints tend to heat first. The components on the board are then heated by conduction. The circuit board, because it has a large surface area, absorbs the thermal energy more efficiently, then distributes this energy to the components. Because of this effect, the main body of a component may be up to 30 degrees cooler than the adjacent solder joints.



**Figure 33. Typical Solder Heating Profile**

# MJD18002D2

## Minimum Pad Sizes Recommended for Surface Mounted Applications

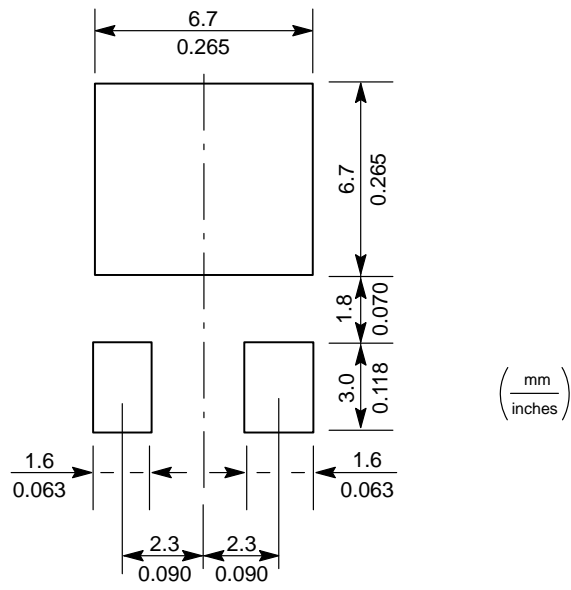

# MJD18002D2

## PACKAGE DIMENSIONS

DPAK  
CASE 369A-13  
ISSUE AA

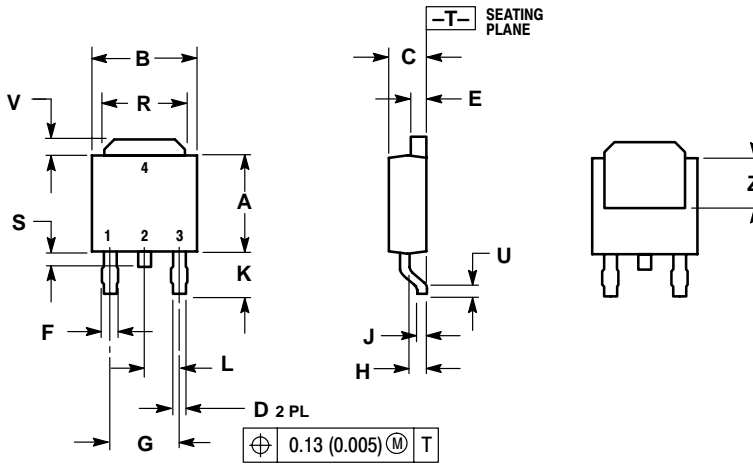

NOTES:

1. DIMENSIONING AND TOLERANCING PER ANSI Y14.5M, 1982.
2. CONTROLLING DIMENSION: INCH.

DIM	INCHES		MILLIMETERS	
	MIN	MAX	MIN	MAX
A	0.235	0.250	5.97	6.35
B	0.250	0.265	6.35	6.73
C	0.086	0.094	2.19	2.38
D	0.027	0.035	0.69	0.88
E	0.033	0.040	0.84	1.01
F	0.037	0.047	0.94	1.19
G	0.180 BSC		4.58 BSC	
H	0.034	0.040	0.87	1.01
J	0.018	0.023	0.46	0.58
K	0.102	0.114	2.60	2.89
L	0.090 BSC		2.29 BSC	
R	0.175	0.215	4.45	5.46
S	0.020	0.050	0.51	1.27
U	0.020	---	0.51	---
V	0.030	0.050	0.77	1.27
Z	0.138	---	3.51	---

STYLE 1:

- PIN 1. BASE
- COLLECTOR
- EMITTER
- COLLECTOR

# MJD18002D2

## PACKAGE DIMENSIONS

### DPAK STRAIGHT LEADS

CASE 369-07

ISSUE M

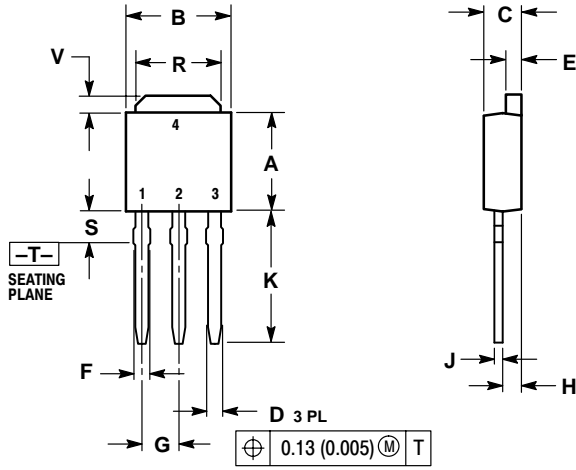

- NOTES:  
 1. DIMENSIONING AND TOLERANCING PER ANSI Y14.5M, 1982.  
 2. CONTROLLING DIMENSION: INCH.

DIM	INCHES		MILLIMETERS	
	MIN	MAX	MIN	MAX
A	0.235	0.250	5.97	6.35
B	0.250	0.265	6.35	6.73
C	0.086	0.094	2.19	2.38
D	0.027	0.035	0.69	0.88
E	0.033	0.040	0.84	1.01
F	0.037	0.047	0.94	1.19
G	0.090 BSC		2.29 BSC	
H	0.034	0.040	0.87	1.01
J	0.018	0.023	0.46	0.58
K	0.350	0.380	8.89	9.65
R	0.175	0.215	4.45	5.46
S	0.050	0.090	1.27	2.28
V	0.030	0.050	0.77	1.27

- STYLE 1:  
 PIN 1. BASE  
 2. COLLECTOR  
 3. EMITTER  
 4. COLLECTOR

# Notes

**ON Semiconductor** and  are trademarks of Semiconductor Components Industries, LLC (SCILLC). SCILLC reserves the right to make changes without further notice to any products herein. SCILLC makes no warranty, representation or guarantee regarding the suitability of its products for any particular purpose, nor does SCILLC assume any liability arising out of the application or use of any product or circuit, and specifically disclaims any and all liability, including without limitation special, consequential or incidental damages. "Typical" parameters which may be provided in SCILLC data sheets and/or specifications can and do vary in different applications and actual performance may vary over time. All operating parameters, including "Typicals" must be validated for each customer application by customer's technical experts. SCILLC does not convey any license under its patent rights nor the rights of others. SCILLC products are not designed, intended, or authorized for use as components in systems intended for surgical implant into the body, or other applications intended to support or sustain life, or for any other application in which the failure of the SCILLC product could create a situation where personal injury or death may occur. Should Buyer purchase or use SCILLC products for any such unintended or unauthorized application, Buyer shall indemnify and hold SCILLC and its officers, employees, subsidiaries, affiliates, and distributors harmless against all claims, costs, damages, and expenses, and reasonable attorney fees arising out of, directly or indirectly, any claim of personal injury or death associated with such unintended or unauthorized use, even if such claim alleges that SCILLC was negligent regarding the design or manufacture of the part. SCILLC is an Equal Opportunity/Affirmative Action Employer.

## PUBLICATION ORDERING INFORMATION

### **NORTH AMERICA Literature Fulfillment:**

Literature Distribution Center for ON Semiconductor  
P.O. Box 5163, Denver, Colorado 80217 USA  
**Phone:** 303-675-2175 or 800-344-3860 Toll Free USA/Canada  
**Fax:** 303-675-2176 or 800-344-3867 Toll Free USA/Canada  
**Email:** ONlit@hibbertco.com  
Fax Response Line: 303-675-2167 or 800-344-3810 Toll Free USA/Canada

**N. American Technical Support:** 800-282-9855 Toll Free USA/Canada

**EUROPE:** LDC for ON Semiconductor – European Support

**German Phone:** (+1) 303-308-7140 (Mon-Fri 2:30pm to 7:00pm CET)  
**Email:** ONlit-german@hibbertco.com

**French Phone:** (+1) 303-308-7141 (Mon-Fri 2:00pm to 7:00pm CET)  
**Email:** ONlit-french@hibbertco.com

**English Phone:** (+1) 303-308-7142 (Mon-Fri 12:00pm to 5:00pm GMT)  
**Email:** ONlit@hibbertco.com

**EUROPEAN TOLL-FREE ACCESS\*: 00-800-4422-3781**

\*Available from Germany, France, Italy, UK, Ireland

### **CENTRAL/SOUTH AMERICA:**

**Spanish Phone:** 303-308-7143 (Mon-Fri 8:00am to 5:00pm MST)  
**Email:** ONlit-spanish@hibbertco.com

**Toll-Free from Mexico:** Dial 01-800-288-2872 for Access –  
then Dial 866-297-9322

**ASIA/PACIFIC:** LDC for ON Semiconductor – Asia Support

**Phone:** 1-303-675-2121 (Tue-Fri 9:00am to 1:00pm, Hong Kong Time)  
**Toll Free from Hong Kong & Singapore:**

**001-800-4422-3781**

**Email:** ONlit-asia@hibbertco.com

**JAPAN:** ON Semiconductor, Japan Customer Focus Center

4-32-1 Nishi-Gotanda, Shinagawa-ku, Tokyo, Japan 141-0031  
**Phone:** 81-3-5740-2700

**Email:** r14525@onsemi.com

**ON Semiconductor Website:** <http://onsemi.com>

For additional information, please contact your local Sales Representative.