

Passive Input Digital Isolators

Functional Diagram

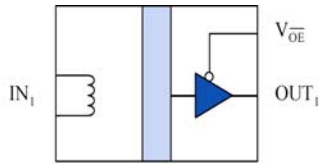

IL610

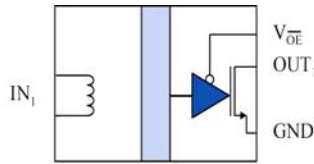

IL610A

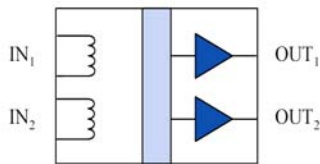

IL611

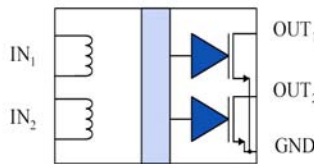

IL611A

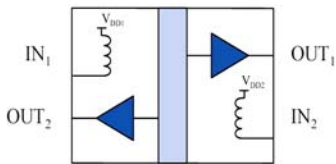

IL612

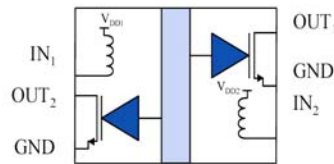

IL612A

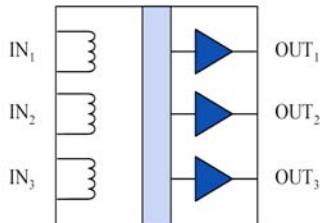

IL613

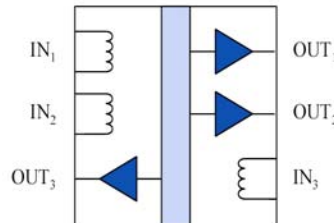

IL614

Features

- 40 Mbps Data Rate
- Very Wide Input Voltage Range
- Open Drain or CMOS Outputs
- Failsafe Output (Logic high output for zero coil current)
- Output Enable
- 3.3 V or 5 V Power Supply
- 2500 V_{RMS} Isolation (1 Minute)
- Low Power Dissipation
- -40°C to 85°C Temperature Range
- 20 kV/μs Typical Common Mode Rejection
- UL1577 & IEC61010 Approval (pending)
- Available in MSOP, SOIC, and PDIP Packages and as Bare Die

Applications

- CAN Bus/ Device Net
- General Purpose Opto Replacement
- Wired-OR Alarms
- SPI interface
- I²C
- RS 485, RS422, RS232
- Digital Fieldbus
- Size critical multi-channel applications

Description

The IL600 series are isolated signal couplers with CMOS or open drain transistor outputs which can be used to replace opto-couplers in many standard isolation functions. The devices are manufactured with NVE's patented IsoLoop[®] GMR sensor technology giving exceptionally small size and low power dissipation.

A single resistor is used to set maximum input current for input voltages above 0.5 V. The devices are available in SOIC, PDIP and MSOP packages and as bare die.

Absolute Maximum Ratings⁽¹⁾

Parameters	Symbol	Min.	Typ.	Max.	Units	Test Conditions
Storage Temperature	T _S	-55		150	°C	
Ambient Operating Temperature	T _A	-55		150	°C	
Supply Voltage	V _{DD}	-0.5		7	V	
Input Current	I _{IN}	-25		25	mA	
Output Voltage	V _O	-0.5		V _{CC} +0.5	V	
Maximum Output Current	I _O	-10		10	mA	
ESD			2		kV	HBM

Recommended Operating Conditions

Parameters	Symbol	Min.	Typ.	Max.	Units	Test Conditions
Ambient Operating Temperature	T _A	-40		85	°C	
Supply Voltage	V _{DD}	3.0		5.5	V	
Input Current	I _{IN}	0		10	mA	
Output Current	I _{OUT}	-4		4	mA	
Open Drain Reverse Voltage	V _{SD}	-0.5			V	
Open Drain Voltage	V _{DS}			6.5	V	
Open Drain Load Current	I _{OD}			4	mA	
Input Signal Rise and Fall Times	t _{IR} , t _{IF}			50	ms	
Common Mode Input Voltage	V _{CM}			400	V _{AC RMS}	

Insulation Specifications

Parameters	Symbol	Min.	Typ.	Max.	Units	Test Conditions
Creepage Distance (external)						
MSOP		3.010			mm	
0.15" SOIC		4.026			mm	
0.30" SOIC		8.077			mm	
0.30" PDIP		7.077			mm	
Internal Isolation Distance			9		µm	
Leakage Current			0.2		µA _{RMS}	240 V _{RMS} , 60 Hz
Barrier Impedance			>10 ¹⁴ 7		Ω pF	

Safety & Approvals

IEC61010-1

TUV Certificate Numbers: *Approval Pending*

Classification

Model	Package	Pollution Degree	Material Group	Max. Working Voltage
IL610-1, IL610A-1, IL611-1, IL611A-1	MSOP	II	III	100 V _{RMS}
IL610-2, IL610A-2, IL611-2, IL611A-2, IL612-2, IL612A-2	PDIP	II	III	300 V _{RMS}
IL610-3, IL610A-3, IL611-3, IL611A-3, IL612-3, IL612A-3, IL613, IL614	SOIC (0.3")	II	III	300 V _{RMS}
IL613-3, IL614-3	SOIC (0.15")	II	III	150 V _{RMS}

UL 1577

Component Recognition program. File #: *Approval Pending*
Rated 2500V_{RMS} for 1 minute (SOIC, PDIP), 1000V_{RMS} for 1 minute (MSOP)

Electrostatic Discharge Sensitivity

This product has been tested for electrostatic sensitivity to the limits stated in the specifications. However, NVE recommends that all integrated circuits be handled with appropriate care to avoid damage. Damage caused by inappropriate handling or storage could range from performance degradation to complete failure.

IL610 and IL610A Pin Connections

1	NC	No internal connection
2	IN+	Coil connection
3	IN-	Coil connection
4	NC	No internal connection
5	GND	Ground return for V_{DD}
6	OUT	Data out
7	V_{OE}	Output enable. Internally held low with 100 k Ω
8	V_{DD}	Supply Voltage

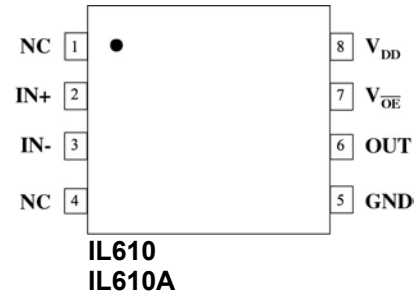

IL611 and IL611A Pin Connections

1	IN ₁₊	Channel 1 coil connection
2	IN ₁₋	Channel 1 coil connection
3	IN ₂₊	Channel 2 coil connection
4	IN ₂₋	Channel 2 coil connection
5	GND	Ground return for V_{DD}
6	OUT ₂	Data out channel 2
7	OUT ₁	Data out channel 1
8	V_{DD}	Supply Voltage

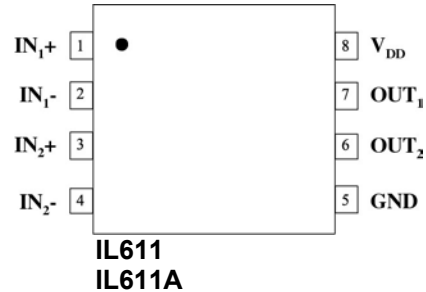

IL612 and IL612A Pin Connections

1	IN ₁	Data in, channel 1
2	V_{DD1}	Supply Voltage 1
3	OUT ₂	Data out, channel 2
4	GND ₁	Ground return for V_{DD1}
5	GND ₂	Ground return for V_{DD2}
6	IN ₂	Data in, channel 2
7	V_{DD2}	Supply Voltage 2
8	OUT ₁	Data out, channel 1

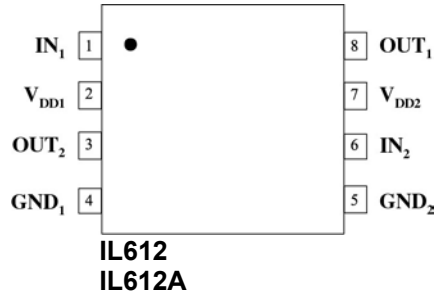

IL613 Pin Connections

1	IN ₁₊	Channel 1 coil connection
2	*	Internally connected to pin 8
3	IN ₁₋	Channel 1 coil connection
4	IN ₂₊	Channel 2 coil connection
5	IN ₂₋	Channel 2 coil connection
6	IN ₃₊	Channel 3 coil connection
7	IN ₃₋	Channel 3 coil connection
8	*	Internally connected to pin 2
9	GND	Ground return for V_{DD} (Internally connected to pin 15)
10	OUT ₃	Data out channel 3
11	NC	No connection
12	V_{DD}	Supply Voltage. Pin 12 and pin 16 must be connected externally
13	OUT ₂	Data out channel 2
14	OUT ₁	Data out channel 1
15	GND	Ground return for V_{DD} (Internally connected to pin 9)
16	V_{DD}	Supply Voltage. Pin 12 and pin 16 must be connected externally

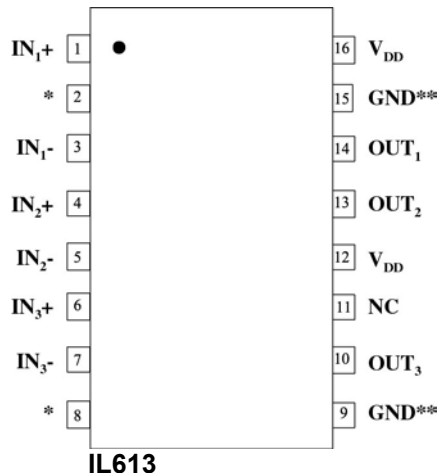

* Pins 2 and 8 internally connected
** Pins 9 and 15 internally connected

IL614 Pin Connections

1	V_{DD1}	Supply Voltage 1
2	GND_1	Ground return for V_{DD1} (Internally connected to pin 8)
3	OUT_1	Data out channel 1
4	\overline{RE}	Channel 1 data output enable. Internally held low with 100 k Ω
5	IN_2	Data in channel 2
6	V_{coil}	Supply connection for channel 2 and channel 3 coils
7	IN_3	Data in channel 3
8	GND_1	Ground return for V_{DD1} (Internally connected to pin 2)
9	GND_2	Ground return for V_{DD2} (Internally connected to pin 15)
10	OUT_3	Data out channel 3
11	NC	No connection
12	V_{DD2}	Supply Voltage 2
13	OUT_2	Data out channel 2
14	IN_1+	Coil connection
15	GND_2	Ground return for V_{DD2} (Internally connected to pin 9)
16	IN_1-	Coil connection

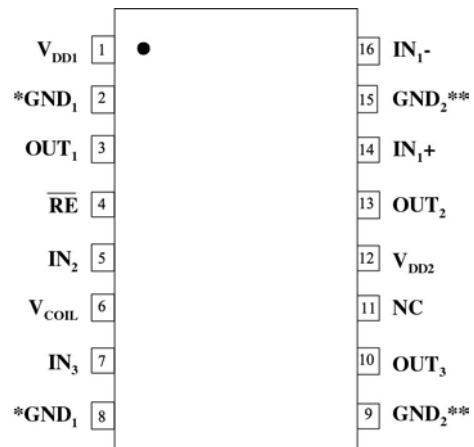

IL614

* Pins 2 and 8 internally connected

** Pins 9 and 15 internally connected

Electrical Specifications

Electrical Specifications are T_{min} to T_{max} unless otherwise stated.

Parameters	Symbol	Min.	Typ.	Max.	Units	Test Conditions
Coil Input Impedance	Z_{COIL}	47 8	55 9	67 10	ΩnH	$T_{AMB} = 25^{\circ}C$
Temperature Coeff of Coil Resistance	$TC R_{COIL}$		0.16	0.165	$\Omega/^{\circ}C$	
Input Threshold for Logic High	$I IN_H$			2	mA	
Input Threshold for Logic Low	$I IN_L$	10			mA	
Quiescent Current	IL610, I_{DD1} IL610, I_{DD2} IL611, I_{DD1} IL611, I_{DD2} IL612, I_{DD1} IL612, I_{DD2} IL613, I_{DD1} IL613, I_{DD2} IL614, I_{DD1} IL614, I_{DD2}		5 2 10 4 2 2 15 6 2 4	10 3 20 6 3 3 30 9 3 6	μA mA μA mA mA mA μA mA mA mA	$V_{DD} = 5 V, I_{IN} = 0$
Quiescent Current	IL610, I_{DD1} IL610, I_{DD2} IL611, I_{DD1} IL611, I_{DD2} IL612, I_{DD1} IL612, I_{DD2} IL613, I_{DD1} IL613, I_{DD2} IL614, I_{DD1} IL614, I_{DD2}		3 1.3 7 2.6 1.3 1.3 10 4 1.3 2.6	7 2 13 4 2 2 20 6 2 4	μA mA μA mA mA mA μA mA mA mA	$V_{DD} = 3.3 V, I_{IN} = 0$
Logic High Output Voltage ⁽⁴⁾	V_{OH}	$V_{DD}-0.1$ V_{DD}	V_{DD} $V_{DD}-0.5$		V	$I_O = -20 \mu A$ $I_O = -4 mA$
Logic Low Output Voltage	V_{OL}		0 0.5	0.1 0.8	V	$I_O = 20 \mu A$ $I_O = 4 mA$
Logic Output Current	I_O	4	7		mA	
Switching Specifications CMOS Outputs						
Data Rate		40			Mbps	50% Duty Cycle
Minimum Pulse Width	PW	25			ns	50% Points, V_o
Propagation Delay Input to Output (High to Low)	t_{PHL}		20	25	ns	$C_L = 15 pF$, $I_{COIL} = 10 mA$
Propagation Delay Input to Output (Low to High)	t_{PLH}		20	25	ns	$C_L = 15 pF$, $I_{COIL} = 10 mA$
Average Propagation Delay Drift			50			ps/ $^{\circ}C$
Pulse Width Distortion $ t_{PHL}-t_{PLH} $ ⁽²⁾	PWD		7	10	ns	$C_L = 15 pF$
Propagation Delay Skew ⁽³⁾	t_{PSK}		10	20	ns	$C_L = 15 pF$
Output Rise Time (10-90%)	t_R		2	4	ns	$C_L = 15 pF$
Output Fall Time (10-90%)	t_F		2	4	ns	$C_L = 15 pF$
Common Mode Transient Immunity	$ CM_H , CM_L $	15	20		kV/ μs	$V_T = 300 V_{peak}$
Switching Specifications Open Drain Outputs						
Parameters	Symbol	Min.	Typ.	Max.	Units	Test Conditions
Data Rate		10			Mbps	50% Duty Cycle, $R_{pullup} = 1 k\Omega$
Minimum Pulse Width	PW	100			ns	50% Duty Cycle, $R_{pullup} = 1 k\Omega$
Propagation Delay Input to Output (High to Low)	t_{PHL}		20	25	ns	$C_L = 2 k\Omega 15 pF$
Propagation Delay Input to Output (Low to High)	t_{PLH}		50	75	ns	$C_L = 2 k\Omega 15 pF$
Common Mode Transient Immunity	$ CM_H , CM_L $	15	20		kV/ μs	$V_T = 300 V_{peak}$

Notes:

1. Absolute Maximum ambient operating temperature means the device will not be damaged if operated under these conditions. It does not guarantee performance.
2. PWD is defined as $|t_{\text{PHL}} - t_{\text{PLH}}|$. %PWD is equal to the PWD divided by the pulse width.
3. t_{PSK} is equal to the magnitude of the worst case difference in t_{PHL} and/or t_{PLH} that will be seen between units at 25°C.
4. The term V_{DD} refers to the supply voltage on the output side of the isolated channel.

Operation

The IL600 series are current mode devices. Changes in current flow into the input coil result in logic state changes at the output. One of the great advantages of the passive coil input is that both single ended and differential inputs can be handled without the need for reverse bias protection. The internal GMR sensor switches the output to logic low if current flows from (In-) to (In+). Only a single resistor is required to limit the input coil to the recommended 10 mA. This allows large input voltages to be used since there is no semiconductor structure on the input.

The absolute maximum current through the coil of the IL600 series is 2.5 mA DC. However, it is important to limit input current to levels well below this in all applications. The worst case logic threshold current is 10 mA. While typical threshold currents are substantially less than this, NVE recommends designing a 10 mA logic threshold current in each application. In all cases, the current must flow from In- to In+ in the coil to switch the output low. This is true regardless of true or inverted data configurations. Output logic high is the zero input current state.

Figure 1 shows the response of the IL600 series. The GMR bridge structure is designed such that the output of the isolator is logic high when no field signal is present. The output will switch to the low state with 10 mA of coil current and the output will switch back to the high state when the input current falls below 2 mA. This allows glitch-free interface with low slew rate signals.

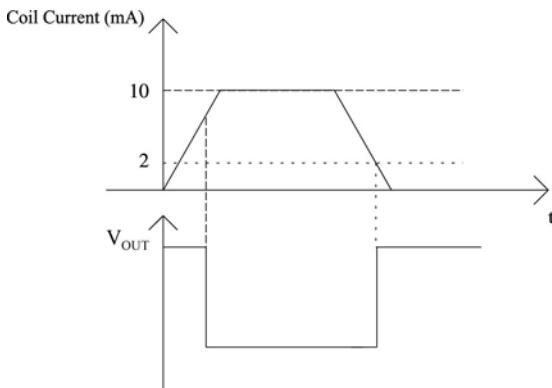

Figure 1. IL600 Series Transfer Function

To calculate the value of the protection resistor (R1) required, use Ohm's law as shown in the examples below. It

should be noted that we are concerned only with the magnitude of the voltage across the coil. The absolute values of $V_{in\ High}$ and $V_{in\ Low}$ are arbitrary.

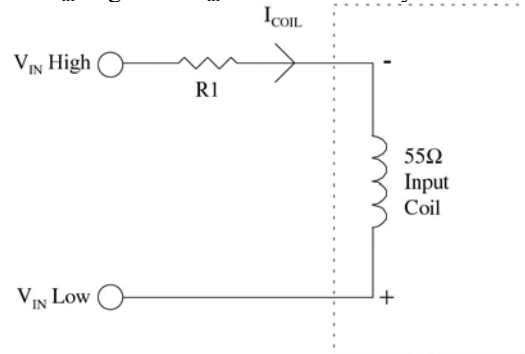

Figure 2. Series Resistor Calculation Equivalent Circuit.

Example 1. In this case, $T_{nom} = 25^{\circ}C$, $V_{in\ High}$ is 24 V, $V_{in\ Low}$ is 1.8 V, and I_{coil} minimum is specified as 10 mA. Total loop resistance is

$$(R1 + R_{coil}) = \frac{(V_{in\ High} - V_{in\ Low})}{I_{coil}} = \frac{22.2}{0.01} \Omega = 2220 \Omega$$

Therefore,

$$R1 = (2220 - 55) \Omega = 2145 \Omega$$

Example 2. At a maximum operating temperature of $85^{\circ}C$, $T_{max} = 85^{\circ}C$, $T_{nom} = 25^{\circ}C$, $V_{in\ High} = 5\ V$, $V_{in\ Low} = 0\ V$, and nominal $R_{coil} = 55\ \Omega$. At $T_{max} = 85^{\circ}C$

$$R_{coil} = 55 + (T_{max} - T_{min}) \times TCR_{coil} \\ = 55 + (85 - 25) \times 0.165 = 55 + 9.9 = 65 \Omega$$

Therefore, the recommended series resistor is

$$R1 = \frac{(V_{in\ High} - V_{in\ Low})}{I_{coil}} - R_{coil} \\ = \frac{5 - 0}{0.01} - 65 = 435 \Omega$$

Allowance should also be made for the temperature coefficient of the current limiting resistor to ensure that I_{coil} is 10 mA at maximum operating temperature.

Power Supplies

It is recommended that 47 nF ceramic capacitors be used to decouple the power supplies. The capacitors must be placed as close as possible to V_{DD} for proper operation.

Application Diagrams

CAN Bus

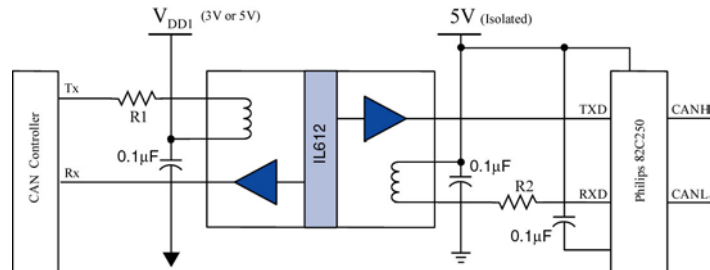

RS232

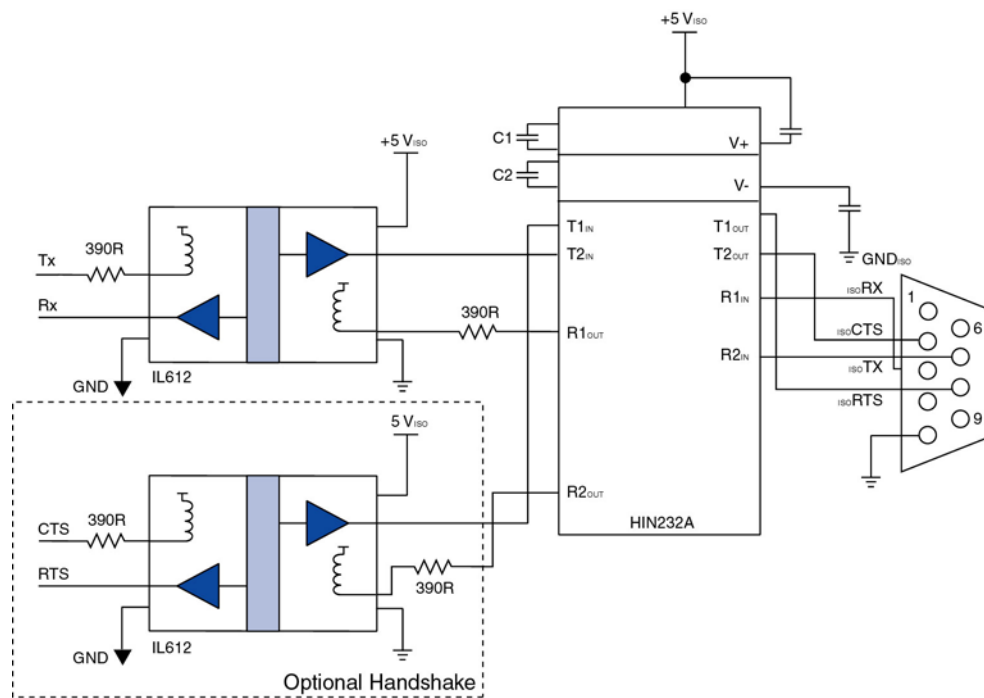

I²C

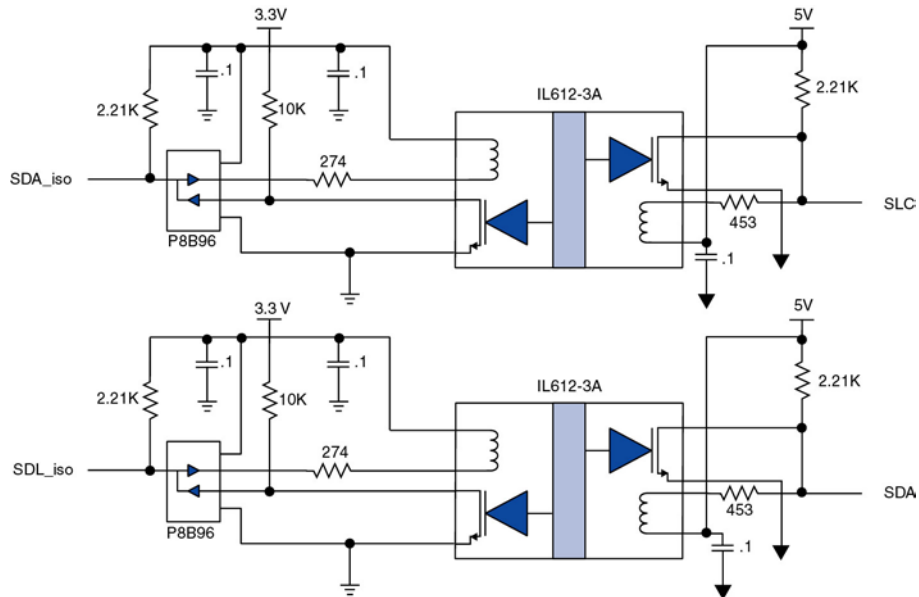

Single Phase Power Control

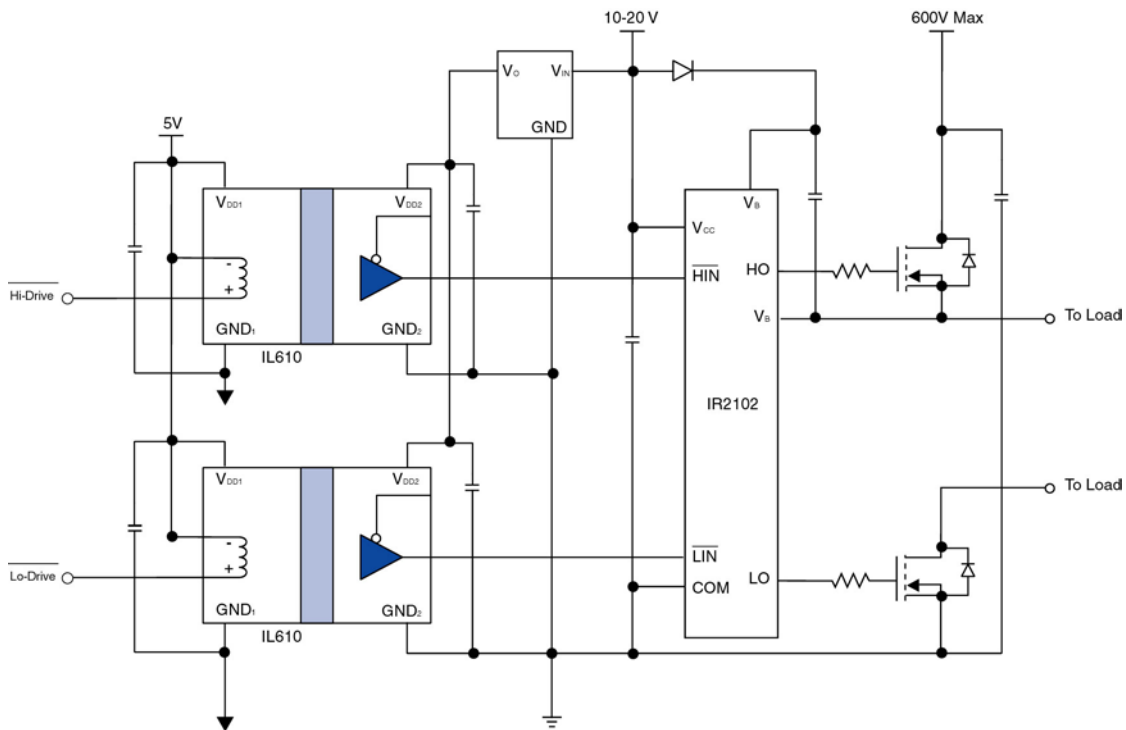

Inverting and Non-Inverting Circuits

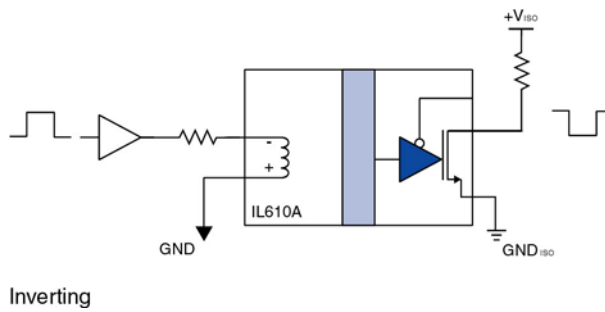
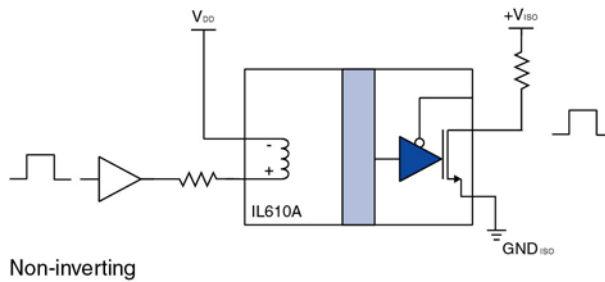

Differential to Single Ended Conversion

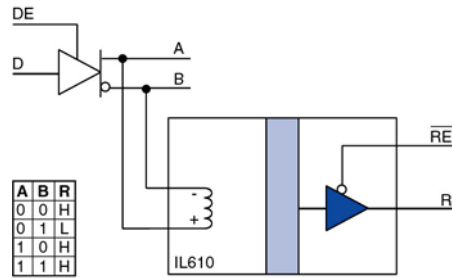

Package drawings, dimensions and specifications

8-pin MSOP Package

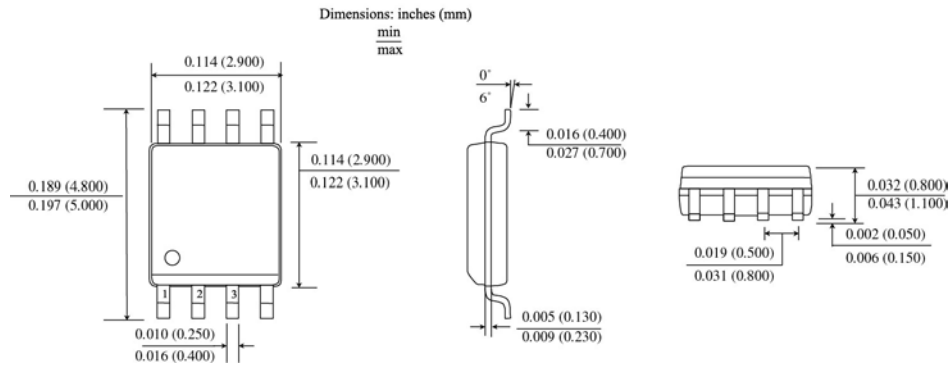

8-pin SOIC Package

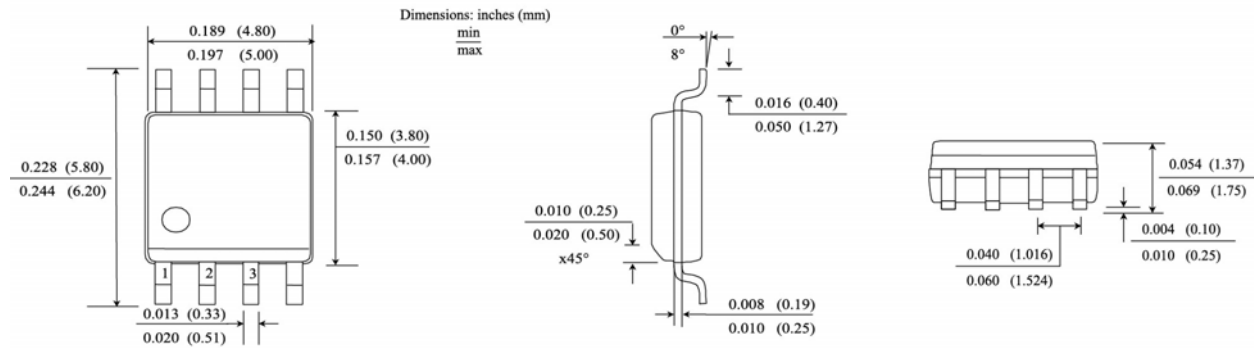

8-pin PDIP Package

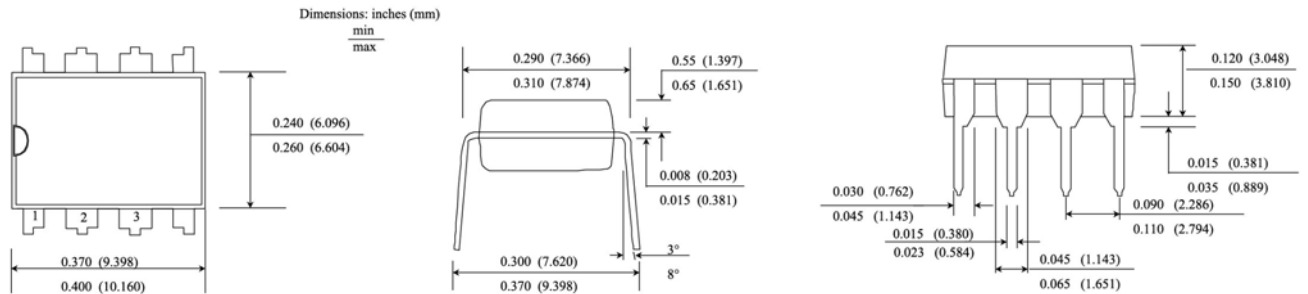

0.15" 16-pin SOIC

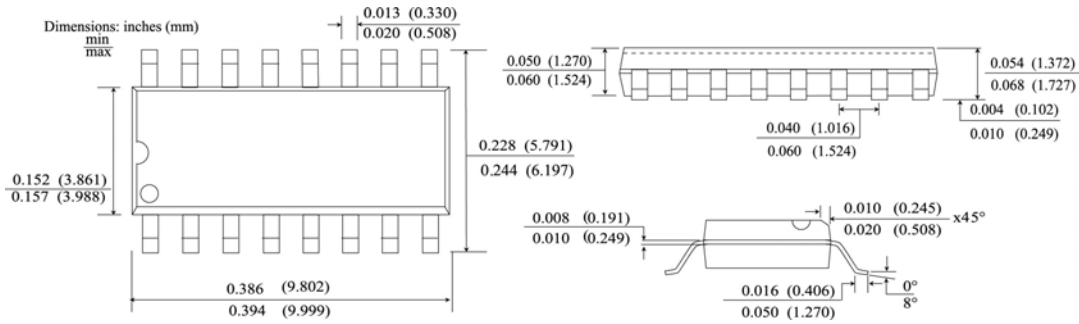

0.30" 16-pin SOIC

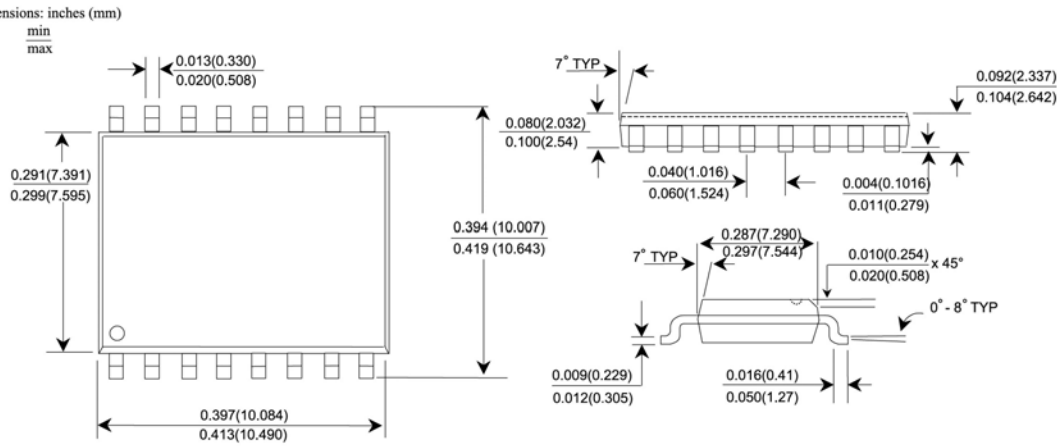

Ordering information and valid part numbers.

IL 610 A - 1 E TR13

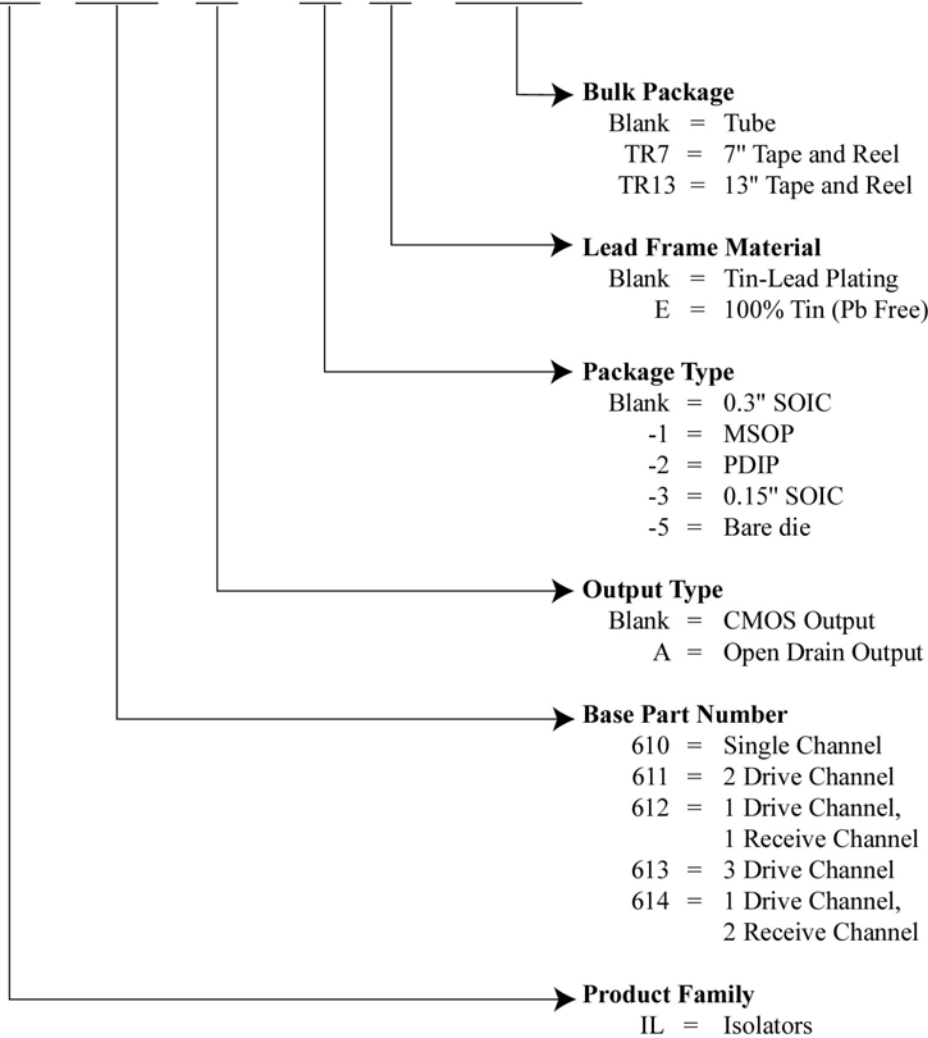

**IL610 Valid
Part Numbers**

- IL610-1
- IL610A-1
- IL610-2
- IL610A-2
- IL610-3
- IL610A-3
- IL610-5
- IL610A-5
- IL610-1TR7
- IL610A-1TR7
- IL610-3TR7
- IL610A-3TR7
- IL610-1TR13
- IL610A-1TR13
- IL610-3TR13
- IL610A-3TR13

**IL611 Valid
Part Numbers**

- IL611-1
- IL611A-1
- IL611-2
- IL611A-2
- IL611-3
- IL611A-3
- IL611-5
- IL611A-5
- IL611-1TR7
- IL611A-1TR7
- IL611-3TR7
- IL611A-3TR7
- IL611-1TR13
- IL611A-1TR13
- IL611-3TR13
- IL611A-3TR13

**IL612 Valid
Part Numbers**

- IL612-2
- IL612A-2
- IL612-3
- IL612A-3
- IL612-3TR7
- IL612A-3TR7
- IL612-3TR13
- IL612A-3TR13

**IL613 Valid
Part Numbers**

- IL613
- IL613TR13
- IL613-3
- IL613-3TR7
- IL613-3TR13

**IL614 Valid
Part Numbers**

- IL614
- IL614TR13
- IL614-3
- IL614-3TR7
- IL614-3TR13

**Lead Free
Part Numbers**
 All part numbers listed above are available in the Lead Free (E) packages.

About NVE

An ISO 9001 Certified Company

NVE Corporation is a high technology components manufacturer having the unique capability to combine leading edge Giant Magnetoresistive (GMR) materials with integrated circuits to make high performance electronic components. Products include Magnetic Field Sensors, Magnetic Field Gradient Sensors (Gradiometer), Digital Magnetic Field Sensors, Digital Signal Isolators and Isolated Bus Transceivers.

NVE is a leader in GMR research and in 1994 introduced the world's first products using GMR material, a line of GMR magnetic field sensors that can be used for position, magnetic media, wheel speed and current sensing.

NVE is located in Eden Prairie, Minnesota, a suburb of Minneapolis. Please visit our Web site at www.nve.com or call 952-829-9217 for information on products, sales or distribution.

NVE Corporation
11409 Valley View Road
Eden Prairie, MN 55344-3617 USA
Telephone: (952) 829-9217
Fax: (952) 829-9189
Internet: www.nve.com
e-mail: isoinfo@nve.com

The information provided by NVE Corporation is believed to be accurate. However, no responsibility is assumed by NVE Corporation for its use, nor for any infringement of patents, nor rights or licenses granted to third parties, which may result from its use. No license is granted by implication, or otherwise, under any patent or patent rights of NVE Corporation. NVE Corporation does not authorize, nor warrant, any NVE Corporation product for use in life support devices or systems or other critical applications. The use of NVE Corporation's products in such applications is understood to be entirely at the customer's own risk.

Specifications shown are subject to change without notice.

ISB-DS-001-IL600-A
January 26, 2005