

## Low-Cost Digital Isolators

### Functional Diagrams

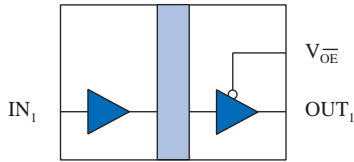

**IL510**

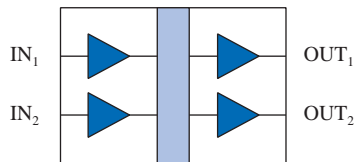

**IL511**

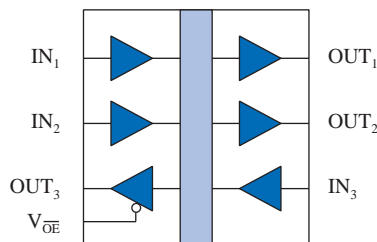

**IL514**

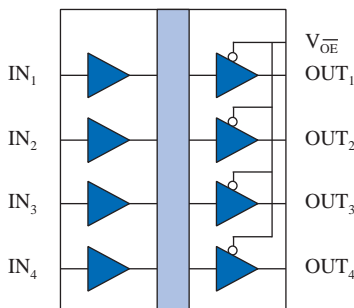

**IL515**

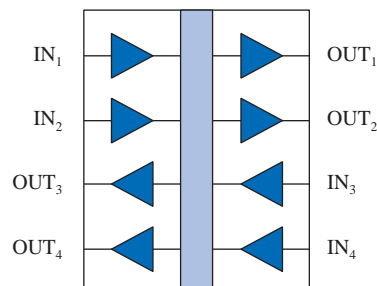

**IL516**

### Features

- +5 V / +3.3 V CMOS/TTL Compatible
- 2 Mbps Maximum Speed
- -40°C to 85°C Operating Temperature
- 2500 V<sub>RMS</sub> Isolation (1 min.)
- 10 ns Pulse Width Distortion
- 25 ns Propagation Delay
- DC-Correct
- 30 kV/μs Typical Common Mode Rejection
- Low EMC Footprint
- 8-pin MSOP; 0.3" and 0.15" 8-pin and 16-pin SOIC Packages
- UL 1577 and IEC 61010-2001 Approved

### Applications

- ADCs and DACs
- Digital Fieldbus
- RS-485 and RS-422
- Multiplexed Data Transmission
- Data Interfaces
- Board-to-Board Communication
- Digital Noise Reduction
- Ground Loop Elimination
- Peripheral Interfaces
- Parallel Bus
- Logic Level Shifting

### Description

IL500-Series isolators are low cost isolators operating up to 2Mbps over an operating temperature range of -40°C to 85°C.

The devices use NVE's patented\* IsoLoop<sup>®</sup> spintronic Giant Magnetoresistive (GMR) technology.

IsoLoop is a registered trademark of NVE Corporation.  
\*U.S. Patent numbers 5,831,426; 6,300,617 and others.

## Absolute Maximum Ratings

Parameters	Symbol	Min.	Typ.	Max.	Units	Test Conditions
Storage Temperature	$T_s$	-55		150	°C	
Ambient Operating Temperature <sup>(1)</sup>	$T_A$	-55		150	°C	
Supply Voltage	$V_{DD1}, V_{DD2}$	-0.5		7	V	
Input Voltage	$V_i$	-0.5		$V_{DD}+0.5$	V	
Output Voltage	$V_o$	-0.5		$V_{DD}+0.5$	V	
Output Current Drive	$I_o$			10	mA	
Lead Solder Temperature				260	°C	10 sec.
ESD			2		kV	HBM

## Recommended Operating Conditions

Parameters	Symbol	Min.	Typ.	Max.	Units	Test Conditions
Ambient Operating Temperature	$T_A$	-40		85	°C	
Supply Voltage	$V_{DD1}, V_{DD2}$	3.0		5.5	V	
Logic High Input Voltage	$V_{IH}$	2.4		$V_{DD}$	V	
Logic Low Input Voltage	$V_{IL}$	0		0.8	V	
Input Signal Rise and Fall Times <sup>(10)</sup>	$t_{IR}, t_{IF}$		DC-Correct			

## Insulation Specifications

Parameters	Symbol	Min.	Typ.	Max.	Units	Test Conditions
Creepage Distance						
MSOP		3.0			mm	
0.15" SOIC (8-pin or 16-pin)		4.0			mm	
0.3" SOIC		8.1			mm	
Leakage Current			0.2		μA	240 V <sub>RMS</sub> , 60 Hz
Barrier Impedance			$>10^{14}  3$		Ω    pF	

## Package Characteristics

Parameters	Symbol	Min.	Typ.	Max.	Units	Test Conditions
Capacitance (Input-Output) <sup>(5)</sup>	$C_{I-O}$		4		pF	f = 1 MHz
Thermal Resistance						
MSOP	$\theta_{JC}$		168		°C/W	Thermocouple at center underside of package
0.15" 8-pin SOIC	$\theta_{JC}$		144		°C/W	
0.15" 16-pin SOIC	$\theta_{JC}$		41		°C/W	
0.3" 16-pin SOIC	$\theta_{JC}$		28		°C/W	
Package Power Dissipation	$P_{PD}$			150	mW	f = 1 MHz, $V_{DD} = 5$ V

## Safety and Approvals

### IEC61010-1

TUV Certificate Numbers: **N1502812, N1502812-101**

### Classification as Reinforced Insulation

Model	Package	Pollution Degree	Material Group	Max. Working Voltage
IL5xx-1	MSOP	II	III	150 V <sub>RMS</sub>
IL5xx-3	8-pin and 16-pin 0.15" SOIC	II	III	150 V <sub>RMS</sub>
IL5xx	0.3" SOIC	II	III	300 V <sub>RMS</sub>

### UL 1577

Component Recognition Program File Number: E207481  
Rated 2500V<sub>RMS</sub> for 1 minute

### Soldering Profile

Per JEDEC J-STD-020C, MSL=2

## IL510 Pin Connections

1	$V_{DD1}$	Supply voltage
2	IN	Data in
3	SYNC	Internal refresh clock disable (normally enabled and internally held low with 10 k $\Omega$ )
4	$GND_1$	Ground return for $V_{DD1}$
5	$GND_2$	Ground return for $V_{DD2}$
6	OUT	Data out
7	$V_{OE}$	Output enable (internally held low with 100 k $\Omega$ )
8	$V_{DD2}$	Supply voltage

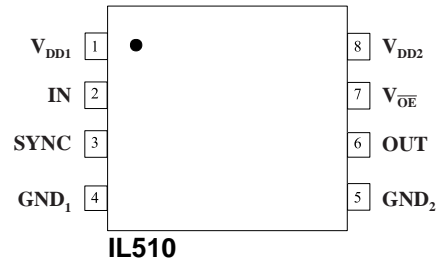

## IL511 Pin Connections

1	$V_{DD1}$	Supply voltage
2	IN <sub>1</sub>	Data in, channel 1
3	IN <sub>2</sub>	Data in, channel 2
4	$GND_1$	Ground return for $V_{DD1}$
5	$GND_2$	Ground return for $V_{DD2}$
6	OUT <sub>2</sub>	Data out, channel 2
7	OUT <sub>1</sub>	Data out, channel 1
8	$V_{DD2}$	Supply voltage

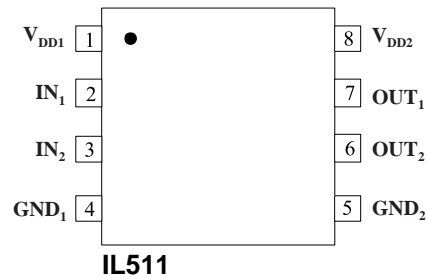

## IL514 Pin Connections

1	$V_{DD1}$	Supply voltage 1
2	$GND_1$	Ground return for $V_{DD1}$ (pin 2 internally connected to pin 8)
3	IN <sub>1</sub>	Data in, channel 1
4	IN <sub>2</sub>	Data in, channel 2
5	OUT <sub>3</sub>	Data out, channel 3
6	NC	No connection
7	$V_{OE}$	Output enable, channel 3 (internally held low with 100 k $\Omega$ )
8	$GND_1$	Ground return for $V_{DD1}$ (pin 8 internally connected to pin 2)
9	$GND_2$	Ground return for $V_{DD2}$ (pin 9 internally connected to pin 15)
10	NC	No connection
11	NC	No connection
12	IN <sub>3</sub>	Data in, channel 3
13	OUT <sub>2</sub>	Data out, channel 2
14	OUT <sub>1</sub>	Data out, channel 1
15	$GND_2$	Ground return for $V_{DD2}$ (pin 15 internally connected to pin 9)
16	$V_{DD2}$	Supply voltage

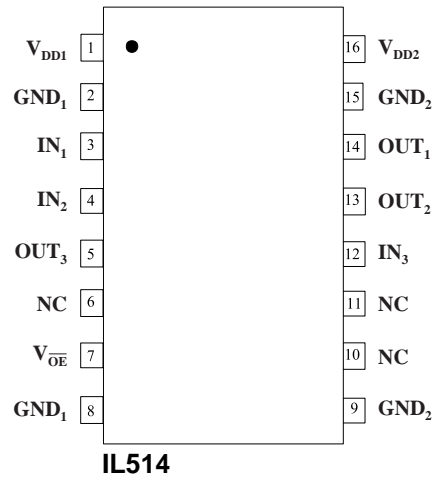

## IL515 Pin Connections

1	V <sub>DD1</sub>	Supply voltage
2	GND <sub>1</sub>	Ground return for V <sub>DD1</sub> (pin 2 internally connected to pin 8)
3	IN <sub>1</sub>	Data in, channel 1
4	IN <sub>2</sub>	Data in, channel 2
5	IN <sub>3</sub>	Data in, channel 3
6	IN <sub>4</sub>	Data in, channel 4
7	SYNC	Internal refresh clock disable (normally enabled and internally held low with 10 kΩ)
8	GND <sub>1</sub>	Ground return for V <sub>DD1</sub> (pin 8 internally connected to pin 2)
9	GND <sub>2</sub>	Ground return for V <sub>DD2</sub> (pin 9 internally connected to pin 15)
10	V <sub>OE</sub>	Output enable (internally held low with 100 kΩ)
11	OUT <sub>4</sub>	Data out, channel 4
12	OUT <sub>3</sub>	Data out, channel 3
13	OUT <sub>2</sub>	Data out, channel 2
14	OUT <sub>1</sub>	Data out, channel 1
15	GND <sub>2</sub>	Ground return for V <sub>DD2</sub> (pin 15 internally connected to pin 9)
16	V <sub>DD2</sub>	Supply voltage

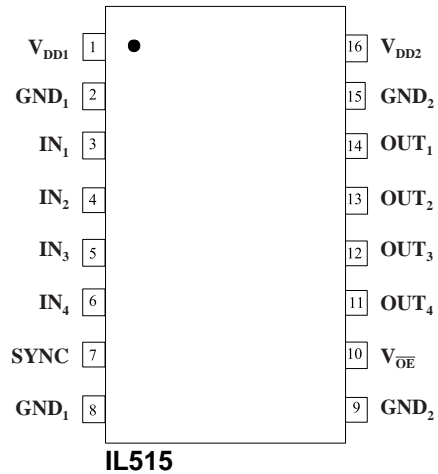

## IL516 Pin Connections

1	V <sub>DD1</sub>	Supply voltage
2	GND <sub>1</sub>	Ground return for V <sub>DD1</sub> (pin 2 internally connected to pin 8)
3	IN <sub>1</sub>	Data in, channel 1
4	IN <sub>2</sub>	Data in, channel 2
5	OUT <sub>3</sub>	Data out, channel 3
6	OUT <sub>4</sub>	Data out, channel 4
7	NC	No connection
8	GND <sub>1</sub>	Ground return for V <sub>DD1</sub> (pin 8 internally connected to pin 2)
9	GND <sub>2</sub>	Ground return for V <sub>DD2</sub> (pin 9 internally connected to pin 15)
10	NC	No connection
11	IN <sub>4</sub>	Data in, channel 4
12	IN <sub>3</sub>	Data in, channel 3
13	OUT <sub>2</sub>	Data out, channel 2
14	OUT <sub>1</sub>	Data out, channel 1
15	GND <sub>2</sub>	Ground return for V <sub>DD2</sub> (pin 15 internally connected to pin 9)
16	V <sub>DD2</sub>	Supply voltage

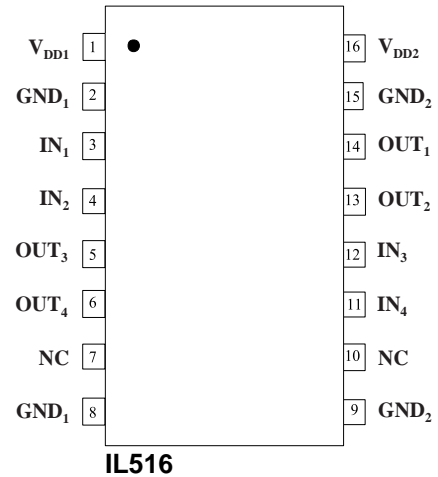

## Timing Diagrams

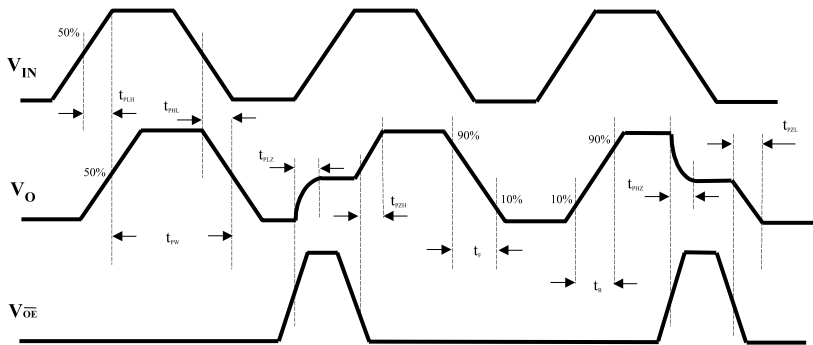

### Legend

$t_{PLH}$	Propagation Delay, Low to High
$t_{PHL}$	Propagation Delay, High to Low
$t_{PW}$	Minimum Pulse Width
$t_{PLZ}$	Propagation Delay, Low to High Impedance
$t_{PZH}$	Propagation Delay, High Impedance to High
$t_{PHZ}$	Propagation Delay, High to High Impedance
$t_{PZL}$	Propagation Delay, High Impedance to Low
$t_R$	Rise Time
$t_F$	Fall Time

## Truth Tables

### Output Enable

$V_I$	$V_{OE}$	$V_O$
L	L	L
H	L	H
L	H	Z
H	H	Z

### SYNC

SYNC	Internal Refresh Clock
0	Enabled
1	Disabled

**Note:** SYNC should be left open or connected to GND to enable the internal refresh clock, or connected to  $V_{DD}$  to disable the internal clock.

## 3.3 Volt Electrical Specifications

Electrical specifications are  $T_{min}$  to  $T_{max}$  unless otherwise stated.

Parameters	Symbol	Min.	Typ.	Max.	Units	Test Conditions
<b>DC Specifications</b>						
Input Quiescent Supply Current						
IL510, IL511, IL515	I <sub>DD1</sub>		15	30	μA	
IL514			1.7	2	mA	
IL516			3.3	4	mA	
Output Quiescent Supply Current						
IL510	I <sub>DD2</sub>		1.7	2	mA	
IL511, IL514, IL516			3.3	4	mA	
IL515			6.6	8	mA	
Logic Input Current	I <sub>I</sub>	-10		10	μA	
Logic High Output Voltage	V <sub>OH</sub>	V <sub>DD</sub> - 0.1	V <sub>DD</sub>		V	I <sub>O</sub> = -20 μA, V <sub>I</sub> = V <sub>IH</sub>
		0.8 x V <sub>DD</sub>	0.9 x V <sub>DD</sub>			I <sub>O</sub> = -4 mA, V <sub>I</sub> = V <sub>IH</sub>
Logic Low Output Voltage	V <sub>OL</sub>		0	0.1	V	I <sub>O</sub> = 20 μA, V <sub>I</sub> = V <sub>IL</sub>
			0.5	0.8		I <sub>O</sub> = 4 mA, V <sub>I</sub> = V <sub>IL</sub>
<b>Switching Specifications</b>						
Maximum Data Rate		2			Mbps	C <sub>L</sub> = 15 pF
Pulse Width <sup>(7)</sup>	PW	20			ns	V <sub>O</sub> 50% points; SYNC=0
		25			ns	V <sub>O</sub> 50% points; SYNC=1
Propagation Delay Input to Output (High to Low)	t <sub>PHL</sub>			25	ns	C <sub>L</sub> = 15 pF
Propagation Delay Input to Output (Low to High)	t <sub>PLH</sub>			25	ns	C <sub>L</sub> = 15 pF
Propagation Delay Enable to Output (High to High Impedance)	t <sub>PHZ</sub>			5	ns	C <sub>L</sub> = 15 pF
Propagation Delay Enable to Output (Low to High Impedance)	t <sub>PLZ</sub>			5	ns	C <sub>L</sub> = 15 pF
Propagation Delay Enable to Output (High Impedance to High)	t <sub>PZH</sub>			5	ns	C <sub>L</sub> = 15 pF
Propagation Delay Enable to Output (High Impedance to Low)	t <sub>PZL</sub>			5	ns	C <sub>L</sub> = 15 pF
Pulse Width Distortion <sup>(2)</sup>	PWD			10	ns	C <sub>L</sub> = 15 pF
Propagation Delay Skew <sup>(3)</sup>	t <sub>PSK</sub>			10	ns	C <sub>L</sub> = 15 pF
Output Rise Time (10%–90%)	t <sub>R</sub>		1	3	ns	C <sub>L</sub> = 15 pF
Output Fall Time (10%–90%)	t <sub>F</sub>		1	3	ns	C <sub>L</sub> = 15 pF
Common Mode Transient Immunity (Output Logic High or Logic Low) <sup>(4)</sup>	CM <sub>H</sub>  ,  CM <sub>L</sub>	20	30		kV/μs	V <sub>CM</sub> = 300 V
Channel-to-Channel Skew	t <sub>CSK</sub>		3	5	ns	C <sub>L</sub> = 15 pF
SYNC Internal Clock Off Time <sup>(11)</sup>	t <sub>OFF</sub>			5	ns	
Dynamic Power Consumption <sup>(6)</sup>			140	240	μA/MHz	per channel
<b>Magnetic Field Immunity<sup>(8)</sup> (V<sub>DD2</sub>= 3V, 3V&lt;V<sub>DD1</sub>&lt;5.5V)</b>						
Power Frequency Magnetic Immunity	H <sub>PF</sub>	1000	1500		A/m	50Hz/60Hz
Pulse Magnetic Field Immunity	H <sub>PM</sub>	1800	2000		A/m	t <sub>p</sub> = 8μs
Damped Oscillatory Magnetic Field	H <sub>OSC</sub>	1800	2000		A/m	0.1Hz – 1MHz
Cross-axis Immunity Multiplier <sup>(9)</sup>	K <sub>X</sub>		2.5			

## 5 Volt Electrical Specifications

Electrical specifications are  $T_{min}$  to  $T_{max}$  unless otherwise stated.

Parameters	Symbol	Min.	Typ.	Max.	Units	Test Conditions
<b>DC Specifications</b>						
Input Quiescent Supply Current						
IL510, IL511, IL515	I <sub>DD1</sub>		24	40	μA	
IL514			2	3	mA	
IL516			5	6	mA	
Output Quiescent Supply Current						
IL510	I <sub>DD2</sub>		2	3	mA	
IL511, IL514, IL516			4	6	mA	
IL515			9	12	mA	
Logic Input Current	I <sub>I</sub>	-10		10	μA	
Logic High Output Voltage	V <sub>OH</sub>	$V_{DD} - 0.1$	$V_{DD}$		V	I <sub>O</sub> = -20 μA, V <sub>I</sub> = V <sub>IH</sub>
		$0.8 \times V_{DD}$	$0.9 \times V_{DD}$			I <sub>O</sub> = -4 mA, V <sub>I</sub> = V <sub>IH</sub>
Logic Low Output Voltage	V <sub>OL</sub>		0	0.1	V	I <sub>O</sub> = 20 μA, V <sub>I</sub> = V <sub>IL</sub>
			0.5	0.8		I <sub>O</sub> = 4 mA, V <sub>I</sub> = V <sub>IL</sub>
<b>Switching Specifications</b>						
Maximum Data Rate		2			Mbps	C <sub>L</sub> = 15 pF
Pulse Width <sup>(7)</sup>	PW	20			ns	V <sub>O</sub> 50% points; SYNC=0
		25			ns	V <sub>O</sub> 50% points; SYNC=1
Propagation Delay Input to Output (High to Low)	t <sub>PHL</sub>			25	ns	C <sub>L</sub> = 15 pF
Propagation Delay Input to Output (Low to High)	t <sub>PLH</sub>			25	ns	C <sub>L</sub> = 15 pF
Propagation Delay Enable to Output (High to High Impedance)	t <sub>PHZ</sub>			5	ns	C <sub>L</sub> = 15 pF
Propagation Delay Enable to Output (Low to High Impedance)	t <sub>PLZ</sub>			5	ns	C <sub>L</sub> = 15 pF
Propagation Delay Enable to Output (High Impedance to High)	t <sub>PZH</sub>			5	ns	C <sub>L</sub> = 15 pF
Propagation Delay Enable to Output (High Impedance to Low)	t <sub>PZL</sub>			5	ns	C <sub>L</sub> = 15 pF
Pulse Width Distortion <sup>(2)</sup>	PWD			10	ns	C <sub>L</sub> = 15 pF
Propagation Delay Skew <sup>(3)</sup>	t <sub>PSK</sub>			10	ns	C <sub>L</sub> = 15 pF
Output Rise Time (10%–90%)	t <sub>R</sub>		1	3	ns	C <sub>L</sub> = 15 pF
Output Fall Time (10%–90%)	t <sub>F</sub>		1	3	ns	C <sub>L</sub> = 15 pF
Common Mode Transient Immunity (Output Logic High or Logic Low) <sup>(4)</sup>	CM <sub>H</sub>  ,  CM <sub>L</sub>	20	30		kV/μs	V <sub>cm</sub> = 300 V
Channel-to-Channel Skew	t <sub>CSK</sub>		3	5	ns	C <sub>L</sub> = 15 pF
SYNC Internal Clock Off Time <sup>(11)</sup>	t <sub>OFF</sub>			5	ns	
Dynamic Power Consumption <sup>(6)</sup>			200	340	μA/MHz	per channel
<b>Magnetic Field Immunity<sup>(8)</sup> (V<sub>DD2</sub> = 5V, 3V &lt; V<sub>DD1</sub> &lt; 5.5V)</b>						
Power Frequency Magnetic Immunity	H <sub>PF</sub>	2,800	3,500		A/m	50Hz/60Hz
Pulse Magnetic Field Immunity	H <sub>PM</sub>	4,000	4,500		A/m	t <sub>p</sub> = 8 μs
Damped Oscillatory Magnetic Field	H <sub>Osc</sub>	4,000	4,500		A/m	0.1Hz – 1MHz
Cross-axis Immunity Multiplier <sup>(9)</sup>	K <sub>X</sub>		2.5			

**Notes (apply to both 3.3 V and 5 V specifications):**

---

1. Absolute maximum ambient operating temperature means the device will not be damaged if operated under these conditions. It does not guarantee performance.
2. PWD is defined as  $|t_{\text{PHL}} - t_{\text{PLH}}|$ . %PWD is equal to PWD divided by pulse width.
3.  $t_{\text{PSK}}$  is the magnitude of the worst-case difference in  $t_{\text{PHL}}$  and/or  $t_{\text{PLH}}$  between devices at 25°C.
4.  $\text{CM}_{\text{H}}$  is the maximum common mode voltage slew rate that can be sustained while maintaining  $V_{\text{O}} > 0.8 V_{\text{DD2}}$ .  $\text{CM}_{\text{L}}$  is the maximum common mode input voltage that can be sustained while maintaining  $V_{\text{O}} < 0.8 \text{ V}$ . The common mode voltage slew rates apply to both rising and falling common mode voltage edges.
5. Device is considered a two terminal device: pins on each side of the package are shorted.
6. Dynamic power consumption is calculated per channel and is supplied by the channel's input side power supply.
7. Minimum pulse width is the minimum value at which specified PWD is guaranteed.
8. The relevant test and measurement methods are given in the Electromagnetic Compatibility section on p. 9.
9. External magnetic field immunity is improved by this factor if the field direction is "end-to-end" rather than to "pin-to-pin" (see diagram on p. 9).
10. If internal clock is used, devices will respond to DC states on inputs within a maximum of 9  $\mu\text{s}$ . Outputs may oscillate if the SYNC input slew rate is less than 1 V/ms.
11.  $t_{\text{off}}$  is the maximum time for the internal refresh clock to shut down.

## Application Information

### Electrostatic Discharge Sensitivity

This product has been tested for electrostatic sensitivity to the limits stated in the specifications. However, NVE recommends that all integrated circuits be handled with appropriate care to avoid damage. Damage caused by inappropriate handling or storage could range from performance degradation to complete failure.

### Electromagnetic Compatibility

IsoLoop Isolators have the lowest EMC footprint of any isolation technology. IsoLoop Isolators' Wheatstone bridge configuration and differential magnetic field signaling ensure excellent EMC performance against all relevant standards.

Additionally, on the IL510 and IL515, the internal clock can be disabled for even better EMC performance.

These isolators are fully compliant with generic EMC standards EN50081, EN50082-1 and the umbrella line-voltage standard for Information Technology Equipment (ITE) EN61000. NVE has completed compliance tests in the categories below:

#### EN50081-1

Residential, Commercial & Light Industrial  
Methods EN55022, EN55014

#### EN50082-2: Industrial Environment

Methods EN61000-4-2 (ESD), EN61000-4-3 (Electromagnetic Field Immunity), EN61000-4-4 (Electrical Transient Immunity), EN61000-4-6 (RFI Immunity), EN61000-4-8 (Power Frequency Magnetic Field Immunity), EN61000-4-9 (Pulsed Magnetic Field), EN61000-4-10 (Damped Oscillatory Magnetic Field)

#### ENV50204

Radiated Field from Digital Telephones (Immunity Test)

Immunity to external magnetic fields is even higher if the field direction is "end-to-end" rather than to "pin-to-pin" as shown in the diagram below:

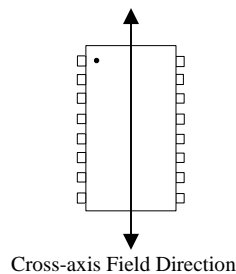

### Dynamic Power Consumption

IsoLoop Isolators achieve their low power consumption from the way they transmit data across the isolation barrier. A magnetic field is created around the GMR Wheatstone bridge by detecting the edge transitions of the input logic signal and converting them to narrow current pulses. Depending on the direction of the magnetic field, the bridge causes the output comparator to switch following the input logic signal. Since the current pulses are narrow, about 2.5 ns, the power consumption is independent of mark-to-space ratio and solely dependent on frequency. This has obvious advantages over optocouplers, which have power consumption heavily dependent on mark-to-space ratio.

### Power Supply Decoupling

Both power supplies to these devices should be decoupled with low ESR ceramic capacitors of at least 47 nF. Capacitors must be located as close as possible to the  $V_{DD}$  pins.

### DC Correctness, EMC, and the SYNC Function

NVE digital isolators have the lowest EMC noise signature of any high-speed digital isolator on the market today because of the dc nature of the GMR sensors used. It is perhaps fair to include optocouplers in that dc category too, but their limited parametric performance, physically large size, and wear-out problems effectively limit side by side comparisons between NVE's isolators and isolators coupled with RF, matched capacitors, or transformers.

IL500-Series isolators has an internal refresh clock which ensure the synchronization of input and output within 9  $\mu$ s of the supply passing the 1.5 V threshold. The IL510 and IL515 allow external control of the refresh clock through the SYNC pin thereby further lowering the EMC footprint. This can be advantageous in applications such as hi-fi, motor control and power conversion.

The isolators can be used with Power on Reset (POR) circuits common in microcontroller applications, as the means of ensuring the output of the device is in the same state as the input a short time after power up. Figure 1 shows a practical Power on Reset circuit:

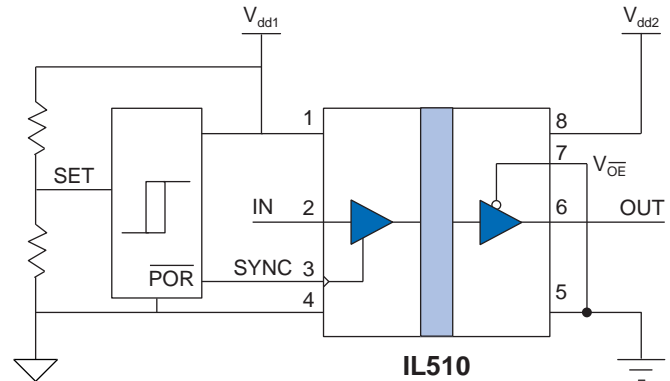
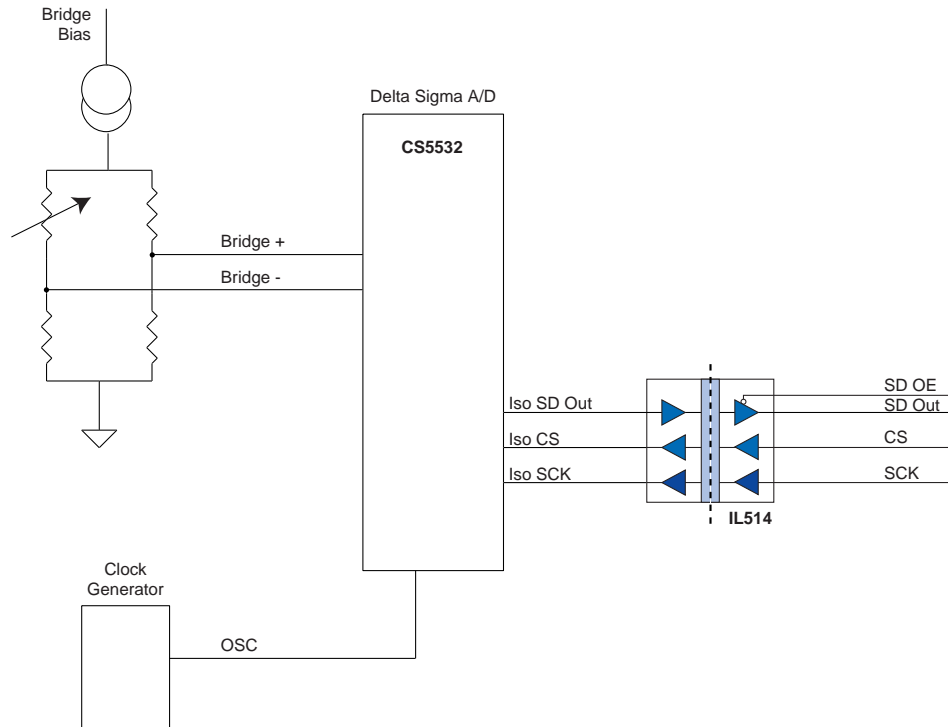

Fig. 1. Typical Power On Reset Circuit for IL510

After POR, the SYNC line goes high, the internal clock is disabled, and the EMC signature is optimized. Decoupling capacitors are omitted for clarity.

## Illustrative Applications

### Isolated A/D Converter



A delta-sigma A-D converter interfaced with the three-channel IL514. Multiple channels can easily be combined using the IL514's output enable function.

## 12-Bit D/A Converter Isolation

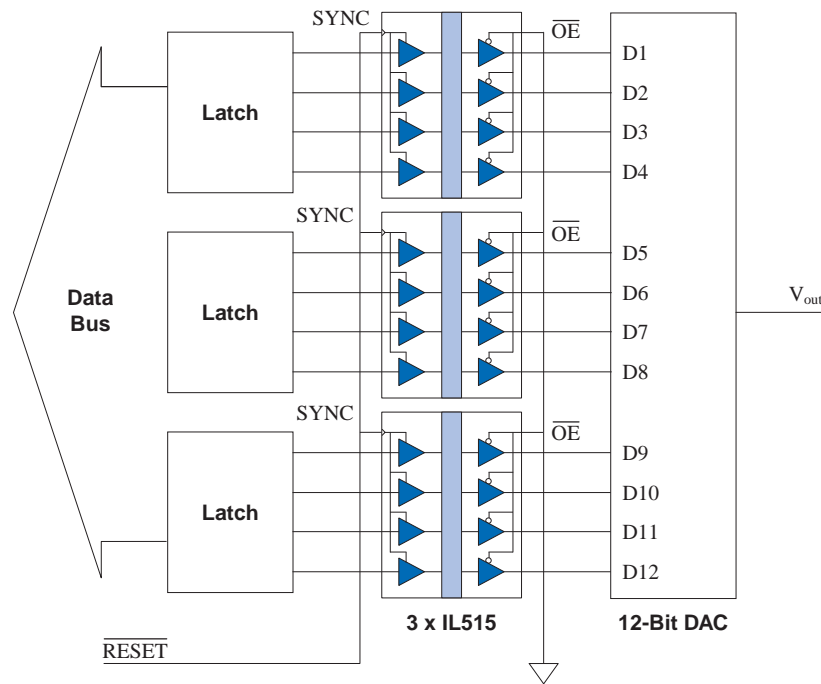

The IL515 four-channel isolator is ideally suited for parallel bus isolation. The circuit above uses three IL515s to isolate a 12-bit DAC. The unique SYNC function automatically synchronizes the outputs to the inputs, ensuring correct data on the isolator outputs. After the reset pulse goes high, data transfer from input to output is initiated by the leading edge of each changing data bit.

## Intelligent DC-DC Converter With Synchronous Rectification

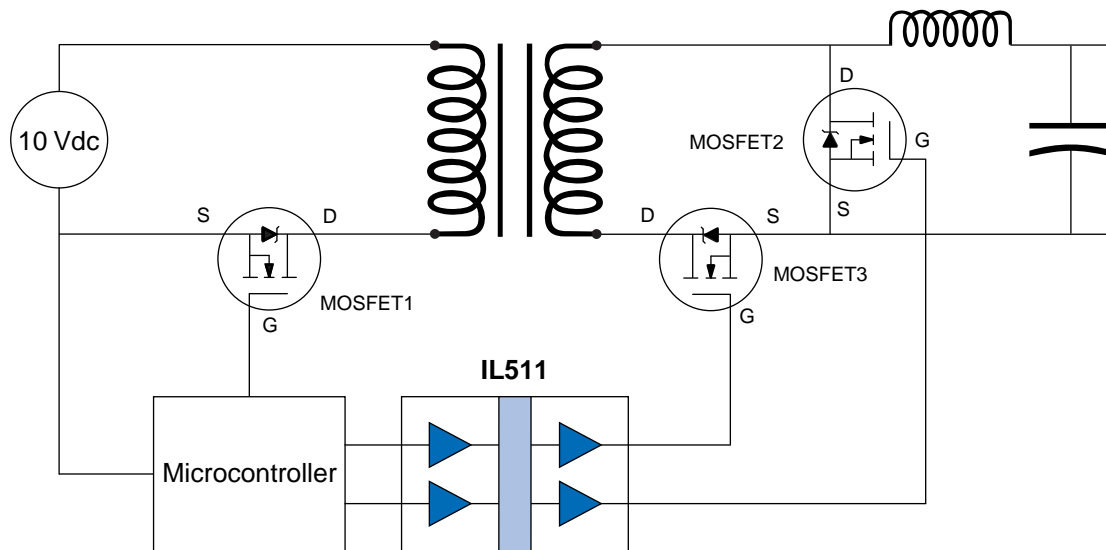

A typical primary-side controller uses the IL511 to drive the synchronous rectification signals from primary side to secondary side. IL511 pulse-width distortion of 10 ns minimizes MOSFET dead time and maximizes efficiency. The ultra-small MSOP package minimizes board area.

## Package Drawings, Dimensions, and Specifications

### 8-pin MSOP

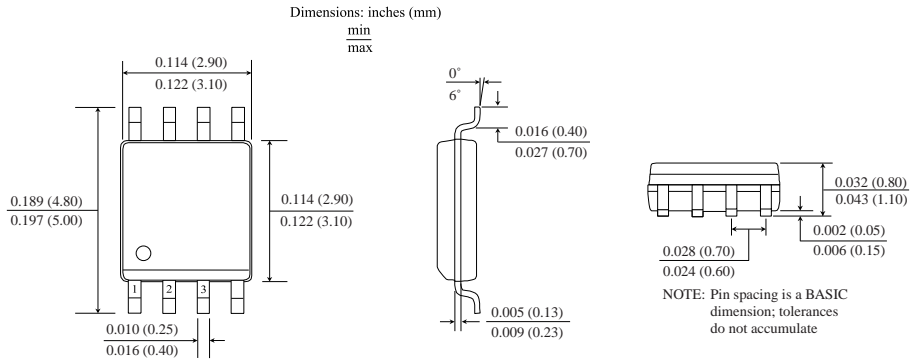

### 8-pin SOIC Package

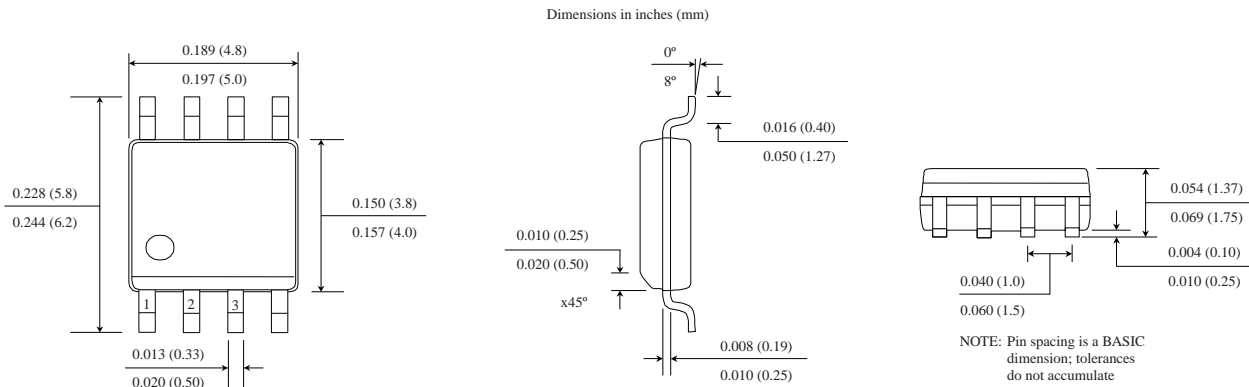

## 16-pin 0.15" SOIC Package

Dimensions in inches (mm)

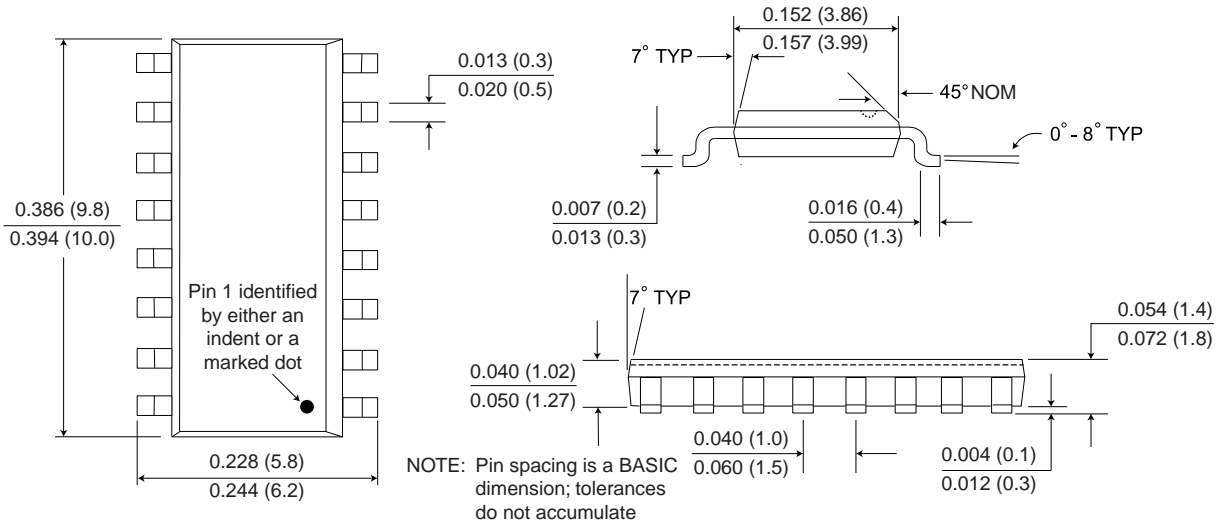

## 16-pin 0.3" SOIC Package

Dimensions in inches (mm)

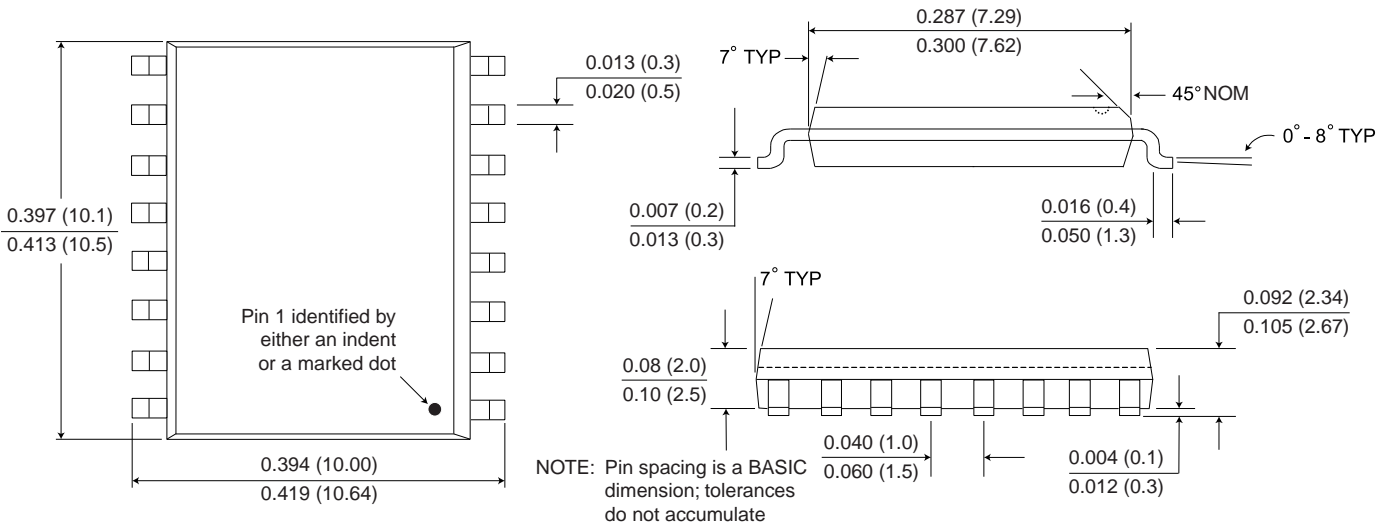

**Ordering Information**

**IL 5 16 - 3 E TR13**

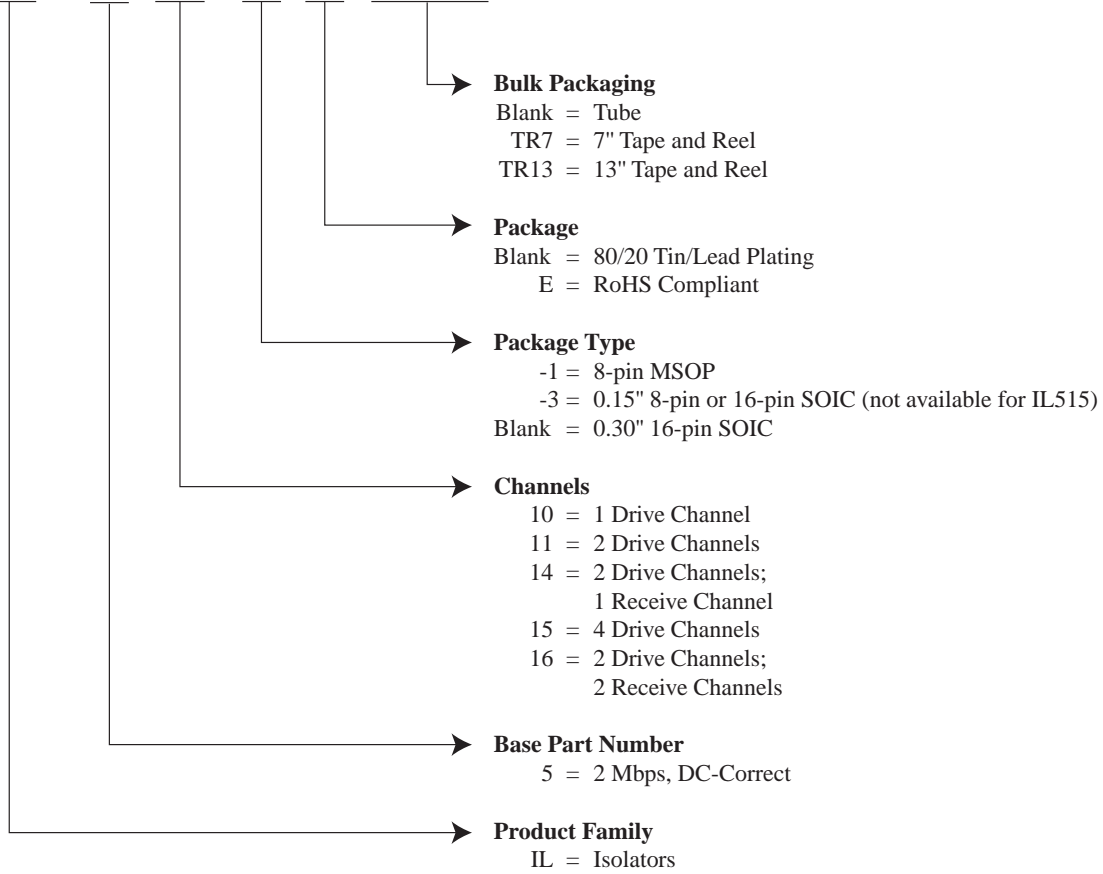

**ISB-DS-001-IL500-I**  
**February 2012**

**Changes:**

- Update terms and conditions.

**ISB-DS-001-IL500-H**

**Changes:**

- Added clarification of internal ground connections (p. 4).

**ISB-DS-001-IL500-G**

**Changes:**

- Clarified SYNC function.

**ISB-DS-001-IL500-F**

**Changes:**

- Changed pin spacing specification on MSOP drawing.

**ISB-DS-001-IL500-E**

**Changes:**

- Added EMC details.

**ISB-DS-001-IL500-D**

**Changes:**

- Add Output Enable to IL515.
- IEC 61010-2001 Approval (removed “pending”).
- Added 12-bit DAC illustrative application.

**ISB-DS-001-IL500-C**

**Production release**

**ISB-DS-001-IL500-B**  
**July 2008**

**Initial release**

**ISB-DS-001-IL500-A**  
**June 2008**

**Preliminary release**

## **Datasheet Limitations**

The information and data provided in datasheets shall define the specification of the product as agreed between NVE and its customer, unless NVE and customer have explicitly agreed otherwise in writing. All specifications are based on NVE test protocols. In no event however, shall an agreement be valid in which the NVE product is deemed to offer functions and qualities beyond those described in the datasheet.

## **Limited Warranty and Liability**

Information in this document is believed to be accurate and reliable. However, NVE does not give any representations or warranties, expressed or implied, as to the accuracy or completeness of such information and shall have no liability for the consequences of use of such information.

In no event shall NVE be liable for any indirect, incidental, punitive, special or consequential damages (including, without limitation, lost profits, lost savings, business interruption, costs related to the removal or replacement of any products or rework charges) whether or not such damages are based on tort (including negligence), warranty, breach of contract or any other legal theory.

## **Right to Make Changes**

NVE reserves the right to make changes to information published in this document including, without limitation, specifications and product descriptions at any time and without notice. This document supersedes and replaces all information supplied prior to its publication.

## **Use in Life-Critical or Safety-Critical Applications**

Unless NVE and a customer explicitly agree otherwise in writing, NVE products are not designed, authorized or warranted to be suitable for use in life support, life-critical or safety-critical devices or equipment. NVE accepts no liability for inclusion or use of NVE products in such applications and such inclusion or use is at the customer's own risk. Should the customer use NVE products for such application whether authorized by NVE or not, the customer shall indemnify and hold NVE harmless against all claims and damages.

## **Applications**

Applications described in this datasheet are illustrative only. NVE makes no representation or warranty that such applications will be suitable for the specified use without further testing or modification.

Customers are responsible for the design and operation of their applications and products using NVE products, and NVE accepts no liability for any assistance with applications or customer product design. It is customer's sole responsibility to determine whether the NVE product is suitable and fit for the customer's applications and products planned, as well as for the planned application and use of customer's third party customers. Customers should provide appropriate design and operating safeguards to minimize the risks associated with their applications and products.

NVE does not accept any liability related to any default, damage, costs or problem which is based on any weakness or default in the customer's applications or products, or the application or use by customer's third party customers. The customer is responsible for all necessary testing for the customer's applications and products using NVE products in order to avoid a default of the applications and the products or of the application or use by customer's third party customers. NVE accepts no liability in this respect.

## **Limiting Values**

Stress above one or more limiting values (as defined in the Absolute Maximum Ratings System of IEC 60134) will cause permanent damage to the device. Limiting values are stress ratings only and operation of the device at these or any other conditions above those given in the recommended operating conditions of the datasheet is not warranted. Constant or repeated exposure to limiting values will permanently and irreversibly affect the quality and reliability of the device.

## **Terms and Conditions of Sale**

In case an individual agreement is concluded only the terms and conditions of the respective agreement shall apply. NVE hereby expressly objects to applying the customer's general terms and conditions with regard to the purchase of NVE products by customer.

## **No Offer to Sell or License**

Nothing in this document may be interpreted or construed as an offer to sell products that is open for acceptance or the grant, conveyance or implication of any license under any copyrights, patents or other industrial or intellectual property rights.

## **Export Control**

This document as well as the items described herein may be subject to export control regulations. Export might require a prior authorization from national authorities.

## **Automotive Qualified Products**

Unless the datasheet expressly states that a specific NVE product is automotive qualified, the product is not suitable for automotive use. It is neither qualified nor tested in accordance with automotive testing or application requirements. NVE accepts no liability for inclusion or use of non-automotive qualified products in automotive equipment or applications.

In the event that customer uses the product for design-in and use in automotive applications to automotive specifications and standards, customer (a) shall use the product without NVE's warranty of the product for such automotive applications, use and specifications, and (b) whenever customer uses the product for automotive applications beyond NVE's specifications such use shall be solely at customer's own risk, and (c) customer fully indemnifies NVE for any liability, damages or failed product claims resulting from customer design and use of the product for automotive applications beyond NVE's standard warranty and NVE's product specifications.

An ISO 9001 Certified Company

NVE Corporation  
11409 Valley View Road  
Eden Prairie, MN 55344-3617 USA  
Telephone: (952) 829-9217  
Fax: (952) 829-9189  
[www.nve.com](http://www.nve.com)  
e-mail: [iso-info@nve.com](mailto:iso-info@nve.com)

©NVE Corporation  
All rights are reserved. Reproduction in whole or in part is prohibited without the prior written consent of the copyright owner.

ISB-DS-001-IL500-I

*February 2012*