

FEATURES

- CLASS I DIELECTRIC, TEMPERATURE COMPENSATING
- HIGH STABILITY OVER TIME, VOLTAGE AND TEMPERATURE CHANGES
- LOW DIELECTRIC LOSS
- NICKEL BARRIER TERMINATIONS AND EXCELLENT MECHANICAL STRENGTH
- EIA MARKING AVAILABLE

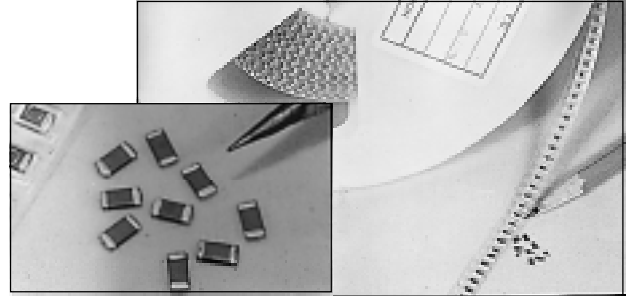

SPECIFICATIONS NPO

Capacitance Range	0.47pF to .056μF
Capacitance Tolerances	Below 10pF: ±0.1pF(B), ±.25pF(C), ±.5pF(D); 10pF and above: ±1%(F), ±2%(G), ±5%(J)
Operating Temperature Range	-55°C to +125°C
Temperature Characteristics	0 ± 30ppm/°C
Rated Voltages	25Vdc, 50Vdc, 100Vdc (see NMC-H Series for Higher Voltages)
Dissipation Factor	For values >30pF 0.1% @25°C; For values ≤30pF Q=400+20xC (C in pF)
Insulation Resistance	100,000 Mohms min. or 1000 Mohm - μF (min.) whichever is less @ +25°C
Dielectric Withstanding Voltage	250% of Rated Voltage for 5 ± 1 seconds, 50 milliamps maximum
Test Conditions (EIA-198-2E)	≤1000pF; 1Mhz, 1.2Vrms Max. or >1000pF; 1khz, 1.2Vrms Max.

TYPICAL NPO TEMPERATURE COEFFICIENT

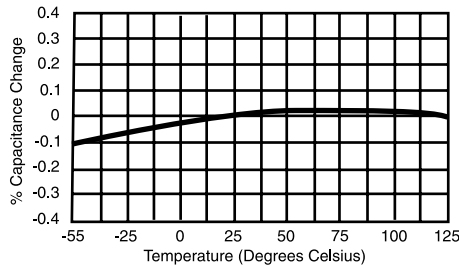

VOLTAGE COEFFICIENT OF CAPACITANCE ~ NPO

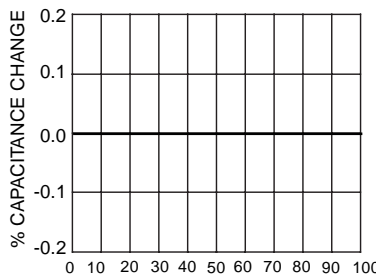

MINIMUM INSULATION RESISTANCE VS TEMPERATURE

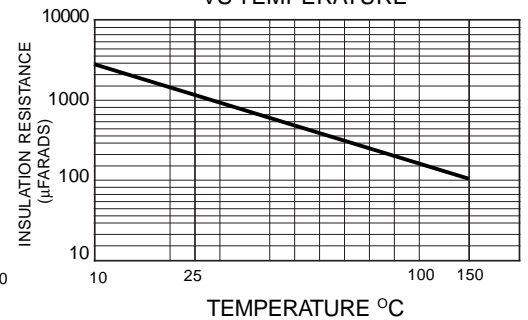

Impedance vs. Frequency - NPO

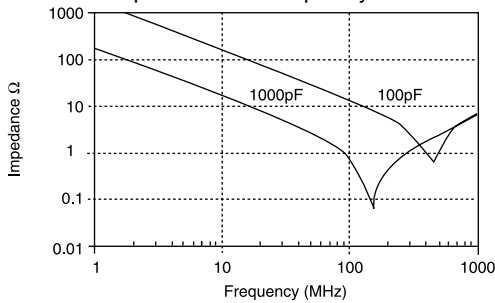

Aging Rate - NPO

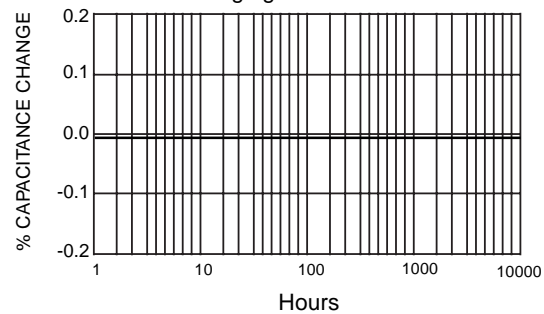

PART NUMBERING SYSTEM

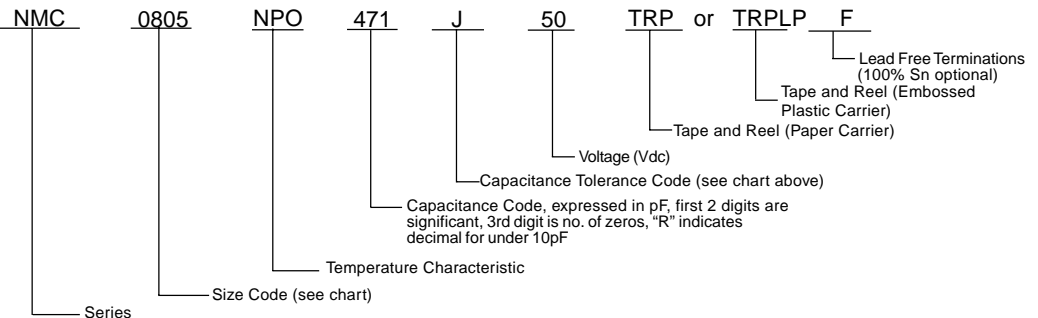

(CONSULT FACTORY
FOR CAPACITANCE
VALUES NOT LISTED)

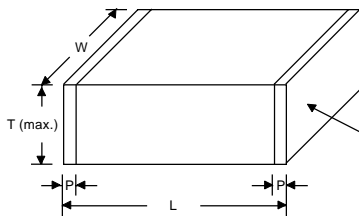

Termination:
Sn-Pb solder plate
finish over nickel
barrier over Ag base.
Also available with
100% Sn lead-free
plating finish.

NPO CAPACITOR SIZE CHART (mm)

EIA Case Size	0201	0402	0603	0805									
Length L	0.6±0.03	1.0±0.05	1.6±0.15	2.0±0.2									
Width W	0.3±0.03	0.5±0.05	0.8±0.15	1.25±0.2									
Thickness (max.) T	0.3±0.03	0.6	1.0	1.30									
Termination Width P	0.15±0.05	0.2±0.1	.12-.51	.25-.71									
Capacitance	Working Voltage												
	10	16	25	50	16	25	50	25	50	100	25	50	100
0.47pF													
1.0													
1.5													
2.2													
2.7													
3.3													
4.7													
6.8													
8.2													
10													
12													
15													
18													
20													
22													
27													
33													
39													
47													
56													
68													
82													
100													
120													
150													
180													
220													
270													
330													
390													
470													
560													
680													
820													
1000													
1500													
1800													
2200													
2700													
3300													
4700													

NPO CAPACITOR SIZE CHART (mm)

EIA Case Size	1206	1210	1812	2225								
Length L	3.2±0.2	3.2±0.2	4.5±0.3	5.7±0.4								
Width W	1.6±0.2	2.5±0.2	3.2±0.25	6.35±0.25								
Thickness (max.) T	1.80	1.80	1.80	1.80								
Termination Width P	.25-.71	.25-.71	.25-.76	.25-1.02								
Capacitance	Working Voltage											
	25	50	100	25	50	100	25	50	100	25	50	100
100												
120												
150												
180												
220												
270												
330												
470												
560												
680												
750												
820												
1000												
1500												
1800												
2200												
2700												
3300												
3900												
4700												
5600												
6800												
8200												
.01µF												
.015												
.018												
.022												
.027												
.033												
.039												
.047												
.056												