

### FEATURES

- SURFACE MOUNT 0402,0603, 0805, 1206, 2010 & 2512 CASE SIZES
- RESISTANCE RANGE (100mΩ ~ 910mΩ)
- THIN FILM CONSTRUCTION
- TOLERANCE RANGE (±1%, ±2% & ±5%)
- REFLOW COMPATIBLE

**RoHS  
Compliant**  
includes all homogeneous materials

See Part Number System for Details



## SEE PAGES 5 & 6 FOR SPECIFICATIONS ON 0815 & 0830 CASE SIZES

### SPECIFICATIONS

Type	EIA Size	Power Rating at 70°C	Resistance Tolerance (Code)	Resistance Range*	Temperature Coefficient (ppm/°C, +25°C ~ +125°C)	Operating Temperature Range (°C)
NCSW04	0402	0.063W	±1% (F) ±5% (J)	All Sizes 100mΩ ~ 910mΩ	100mΩ ~ 500mΩ ±300ppm	-55°C ~ +155°C
NCSW06	0603	0.125W			501mΩ ~ 910mΩ ±200ppm	
NCSW10	0805	0.25W			±200ppm	
NCSW12	1206	0.50W				
NCSW20	2010	0.75W				
NCSW25	2512	1.0W				

\*Contact NIC regarding current availability

### PART NUMBER SYSTEM

NCSW 12 E R110 TR E

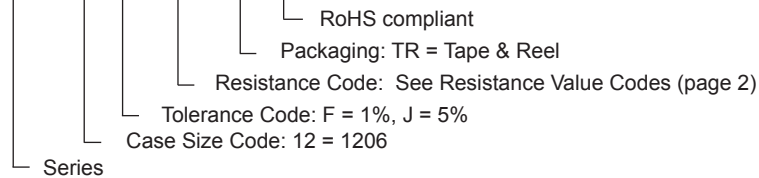

### COMPONENT DIMENSIONS AND MARKING

Case Size	L	W	T	P1	P2
0402	1.00 ± 0.10	0.50 ± 0.05	0.35 ± 0.05	0.25 ± 0.10	0.20 ± 0.10
0603	1.60 ± 0.10	0.80 ± 0.10	0.45 ± 0.10	0.35 ± 0.20	0.30 ± 0.20
0805	2.00 ± 0.10	1.25 ± 0.10	0.50 ± 0.10	0.35 ± 0.20	0.40 ± 0.20
1206	3.10 ± 0.20	1.55 ± 0.10	0.55 ± 0.10	0.40 ± 0.20	0.50 ± 0.30
2010	5.00 ± 0.20	2.50 ± 0.20	0.55 ± 0.10	0.50 ± 0.25	0.60 ± 0.30
2512	6.30 ± 0.20	3.20 ± 0.20	0.55 ± 0.10	0.50 ± 0.25	0.60 ± 0.30

(0402 & 0603 parts are not marked)

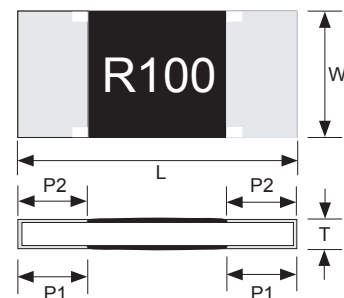

## RESISTANCE VALUE CODES (Values in milli-ohms)

E-24		E-96							
Value	Code	Value	Code	Value	Code	Value	Code	Value	Code
100	R100	100	R100	102	R102	105	R105	107	R107
110	R110	110	R110	113	R113	115	R115	118	R118
120	R120	121	R121	124	R124	127	R127	130	R130
130	R130	133	R133	137	R137	140	R140	143	R143
150	R150	147	R147	150	R150	154	R154	158	R158
160	R160	162	R162	165	R165	169	R169	174	R174
180	R180	178	R178	182	R182	187	R187	191	R191
200	R200	196	R196	200	R200	205	R205	210	R210
220	R220	215	R215	221	R221	226	R226	232	R232
240	R240	237	R237	243	R243	249	R249	255	R255
270	R270	261	R261	267	R267	274	R274	280	R280
300	R300	287	R287	294	R294	301	R301	309	R309
330	R330	316	R316	324	R324	332	R332	340	R340
360	R360	348	R348	357	R357	365	R365	374	R374
390	R390	383	R383	392	R392	402	R402	412	R412
430	R430	422	R422	432	R432	442	R442	453	R453
470	R470	464	R464	475	R475	487	R487	499	R499
510	R510	511	R511	523	R523	536	R536	549	R549
560	R560	562	R562	576	R576	590	R590	604	R604
620	R620	619	R619	634	R634	649	R649	665	R665
680	R680	681	R681	698	R698	715	R715	732	R732
750	R750	750	R750	768	R768	787	R787	806	R806
820	R820	825	R825	845	R845	866	R866	887	R887
910	R910	909	R909						

## ENVIRONMENTAL CHARACTERISTICS

Item	Specification		Test Method	Reference Standard
	±1% tol.	±2% & ±5% tol.		
Temperature Coefficient of Resistance	Within specified value		-55°C ~ +125°C	IEC60115-1 4.8 JIS-C5201 4.8
Load Life	<±1% +0.001Ω	<±3% +0.001Ω	+70°C, 1,000 hours at rated power 1.5 hours ON, 0.5 hours OFF	IEC60115-1 4.25.1 JIS-C5201 4.25.1
Short Time Overload	<±1% +0.005Ω	<±3% +0.005Ω	2.5 x rated voltage for 5 seconds	IEC60115-1 4.13 JIS-C5201 4.13
Moisture Resistance (at rated voltage)	<±1% +0.001Ω	<±3% +0.001Ω	+40°C, 90~95% RH, 1000 hours 1.5 hours on, 0.5 hours off	IEC60115-1 4.24 JIS-C5201 4.24
Temperature Cycling	<±1% +0.005Ω		-55°C (30 minutes) & +155°C (30 minutes) 5 cycles	IEC60115-1 4.19 JIS-C5201 4.19
Resistance to Soldering Heat	<±1% +0.005Ω		+270°C ± 5°C for 10 sec. ±1 sec.	IEC60115-1 4.18 JIS-C5201 4.18
Solderability	At least 95% coverage of electrode surface		+245°C ± 5°C, 2 sec. ± 0.5sec. Sn 96.5 / Ag 3.0 / Cu 0.5	IEC60115-1 4.17 JIS-C5201 4.17
High Temperature Exposure	<±1% +0.005Ω	<±2% +0.005Ω	+155°C for 96 hours	IEC60115-1 4.23.2 JIS-C5201 4.23.2
Substrate Bending	<±1% +0.005Ω		0402 ~ 1206 3mm deflection 2010 & 2512 2mm deflection	IEC60115-1 4.33 JIS-C5201 4.33

**Power Derating Curve:** For operation above 70°C, power rating must be derated according to the following chart:

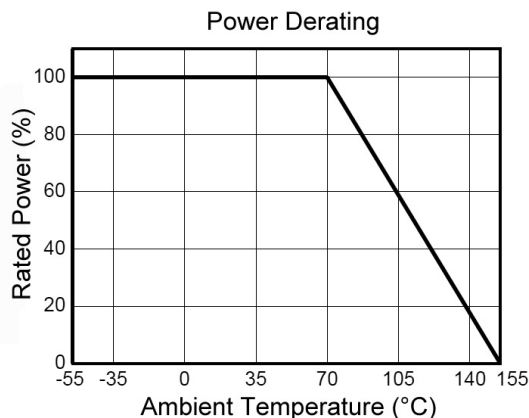

## RECOMMENDED LAND PATTERN DIM. (mm)

Case Size	A	B	C
0402	0.50 ~ 0.60	0.40 ~ 0.55	0.40 ~ 0.60
0603	0.70 ~ 0.90	0.55 ~ 0.75	0.80 ~ 1.00
0805	1.00 ~ 1.40	0.90 ~ 1.40	0.90 ~ 1.40
1206	2.00 ~ 2.40	1.00 ~ 1.50	1.20 ~ 1.80
2010	3.30 ~ 3.70	1.00 ~ 1.60	2.30 ~ 3.50
2512	3.60 ~ 4.00	1.80 ~ 2.50	2.30 ~ 3.50

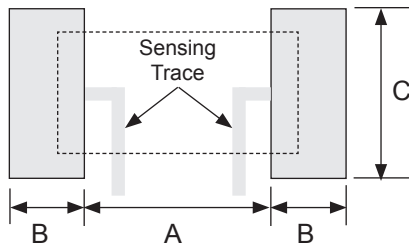

## RECOMMENDED REFLOW SOLDERING TEMPERATURE PROFILE

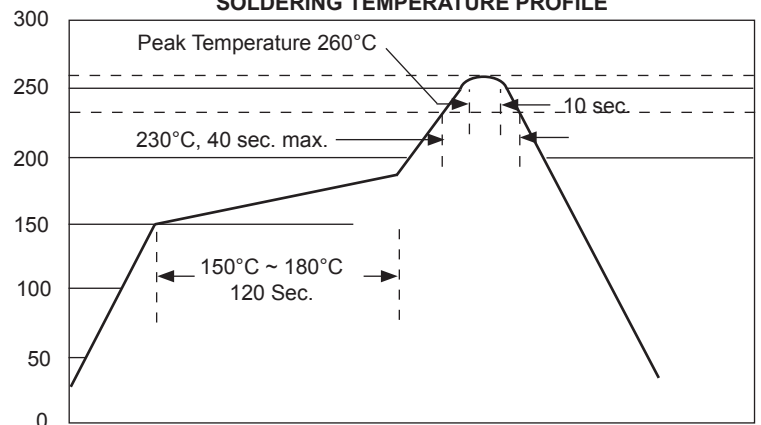

## PAPER TAPE DIMENSIONS (mm)

Case Size	A	B	K	P	P <sub>1</sub>	E	F	D <sub>0</sub>	W	Quantity per Reel
0402	0.70 ± 0.05	1.20 ± 0.05	0.45 ± 0.10	4.0 ± 0.1	2.0 ± 0.1	1.75 ± 0.1	3.5 ± 0.05	1.50 ± 0.1	8.0 ± 0.2	10,000
0603	1.10 ± 0.10	1.90 ± 0.1	0.64 ± 0.10		4.0 ± 0.1					5,000
0805	1.60 ± 0.15	2.40 ± 0.2	0.85 ± 0.15		4.0 ± 0.1					5,000
1206	2.00 ± 0.15	3.60 ± 0.2			5,000					

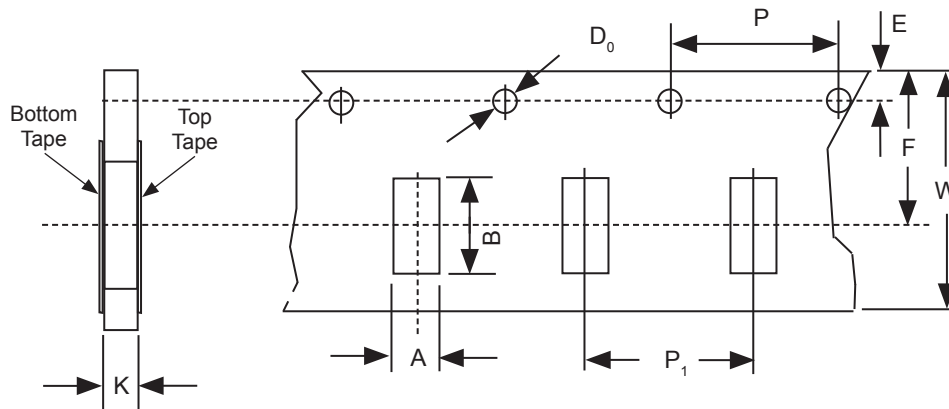

### EMBOSED PLASTIC CARRIER DIMENSIONS (mm)

Case Size	A	B	K	P	P <sub>1</sub>	E	F	D <sub>0</sub>	W	Quantity per Reel
2010	2.80 ± 0.20	5.30 ± 0.2	0.85 ± 0.15	4.0 ± 0.1	4.0 ± 0.1	1.75 ± 0.1	5.5 ± 0.05	1.50 <sup>+0.1</sup> / <sub>-0</sub>	12.0 ± 0.2	4,000
2512	3.60 ± 0.20	6.90 ± 0.2								4,000

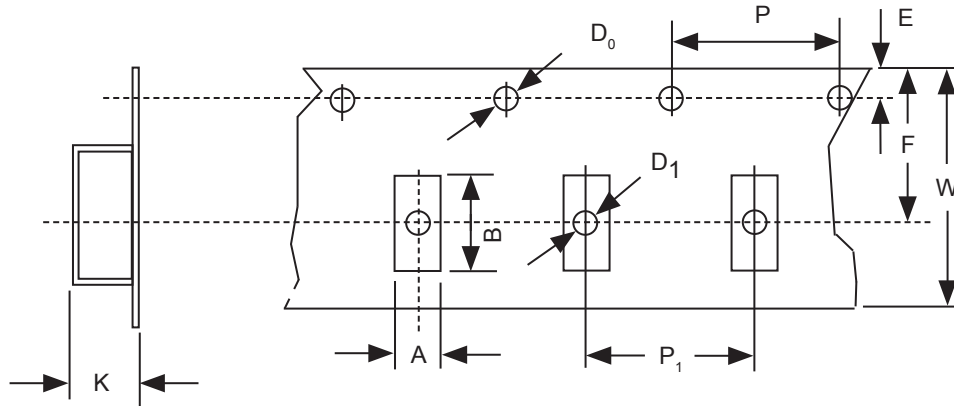

### REEL DIMENSIONS (mm) AND QUANTITY

Case Size	A	B	C	W	Quantity
0603	178 ± 2.0	60 ± 1.0	13 ± 1.0	9.0 ± 1.0	5,000
0805					5,000
1206					5,000
2010				13.0 ± 1.0	4,000
2512					4,000

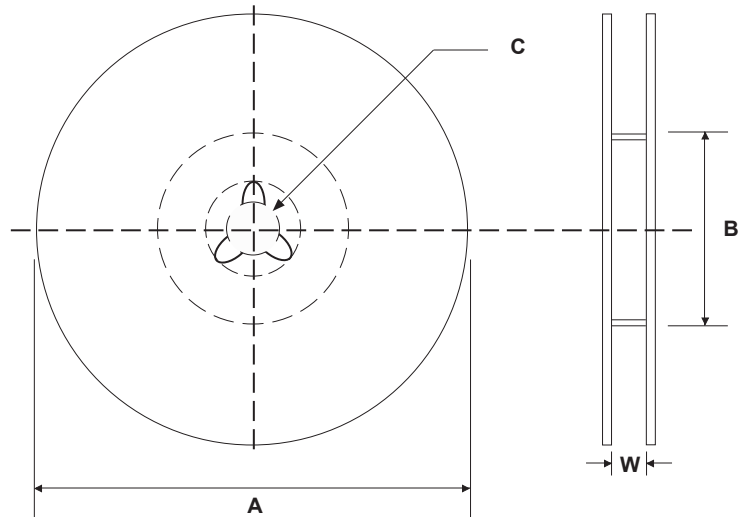

### FEATURES

- ULTRA LOW RESISTANCE VALUES
- PRECISION TOLERANCE AND TEMPERATURE STABILITY
- THIN FILM CONSTRUCTION
- IDEAL FOR CURRENT SENSING APPLICATIONS
- AVAILABLE IN 1 WATT ~ 2 WATT POWER RATINGS



**RoHS Compliant**  
includes all homogeneous materials

\*See Part Number System for Details

### CHARACTERISTICS

Type	size	Power Rating	Resistance Tolerance (Code)	Temperature Coefficient (ppm/°C)	Resistance Range (Ω)	Resistance Value	Operating Temperature Range (°C)	
NCSW100	0815	1W @ +70°C	1% (F), 2% (G)	±50 (Q), ±100 (R)	0.1 ~ 1.0	E-6	-55°C ~ +125°C	
				0 ~ +200 (S)	0.01 ~ 0.068			
				0 ~ +350 (T)	0.002 ~ 0.009			
NCSW200	0830	2W @ +30°C	±1% (F), 2% (G)	±50 (Q), ±100 (R)	0.1 ~ 0.47	E-6	-55°C ~ +155°C	
				±1% (F), 2% (G)	0 ~ +200 (S)			0.01 ~ 0.068
				±5% (J)	0 ~ +350 (T)			0.001 ~ 0.009

### DIMENSIONS (mm)

Series	W	L	T	P
NCSW100	3.75 ± 0.30	2.00 ± 0.20	0.55 max.	0.40 ± 0.20
NCSW200	7.50 ± 0.30	2.00 ± 0.20	0.55 max.	0.40 ± 0.20

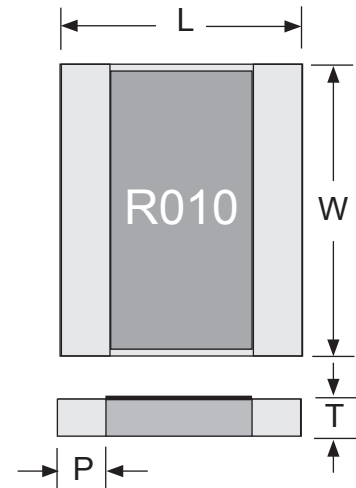

### PART NUMBER SYSTEM

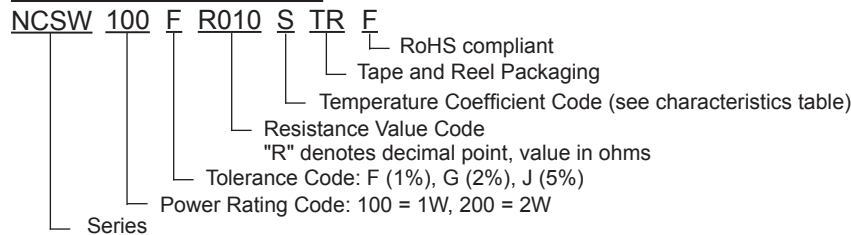

**Power Derating Curve:** For operation above +70°C for NCSW100 and +30°C for NCSW200, power rating must be derated according to the following chart:

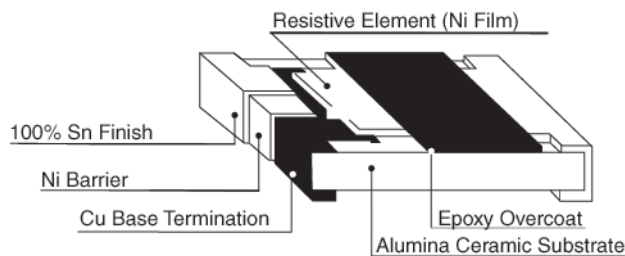
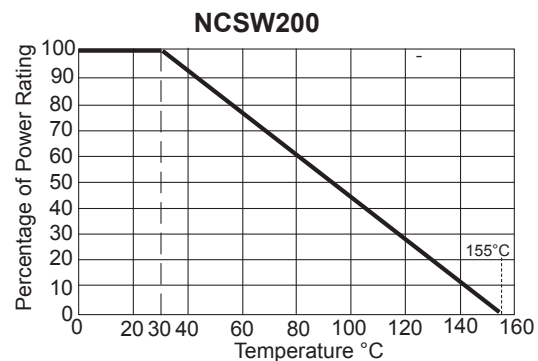
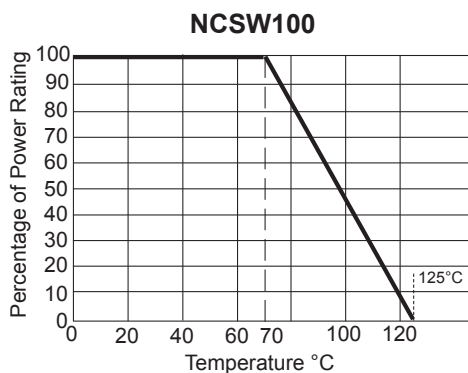

## RESISTANCE VALUE CODES (Values in milli-ohms)

E-24		E-96							
Value	Code	Value	Code	Value	Code	Value	Code	Value	Code
100	R100	100	R100	102	R102	105	R105	107	R107
110	R110	110	R110	113	R113	115	R115	118	R118
120	R120	121	R121	124	R124	127	R127	130	R130
130	R130	133	R133	137	R137	140	R140	143	R143
150	R150	147	R147	150	R150	154	R154	158	R158
160	R160	162	R162	165	R165	169	R169	174	R174
180	R180	178	R178	182	R182	187	R187	191	R191
200	R200	196	R196	200	R200	205	R205	210	R210
220	R220	215	R215	221	R221	226	R226	232	R232
240	R240	237	R237	243	R243	249	R249	255	R255
270	R270	261	R261	267	R267	274	R274	280	R280
300	R300	287	R287	294	R294	301	R301	309	R309
330	R330	316	R316	324	R324	332	R332	340	R340
360	R360	348	R348	357	R357	365	R365	374	R374
390	R390	383	R383	392	R392	402	R402	412	R412
430	R430	422	R422	432	R432	442	R442	453	R453
470	R470	464	R464	475	R475	487	R487	499	R499
510	R510	511	R511	523	R523	536	R536	549	R549
560	R560	562	R562	576	R576	590	R590	604	R604
620	R620	619	R619	634	R634	649	R649	665	R665
680	R680	681	R681	698	R698	715	R715	732	R732
750	R750	750	R750	768	R768	787	R787	806	R806
820	R820	825	R825	845	R845	866	R866	887	R887
910	R910	909	R909						

### LAND PATTERN DIMENSIONS (mm)

Type	A	B	C
NCSW100	1.4	1.2	7.9
NCSW200	1.4	1.2	15.8

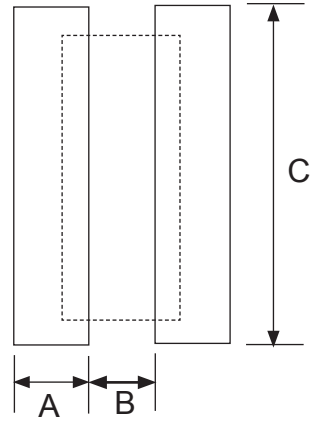

### EMBOSED PLASTIC CARRIER DIMENSIONS (mm)

Type	A ± 0.1	B ± 0.2	W ± 0.3	F ± 0.10	E ± 0.1	P <sub>0</sub> ± 0.1	P <sub>1</sub> ± 0.1	φD ± 0.05	φD <sub>1</sub> ± 0.05	T ± 0.05	K ± 0.2
NCSW100	2.40	4.25	12.0	5.50	1.75	4.0	4.0	1.55	-	0.3	0.7
NCSW200	2.40	8.00	16.0	7.50					-		

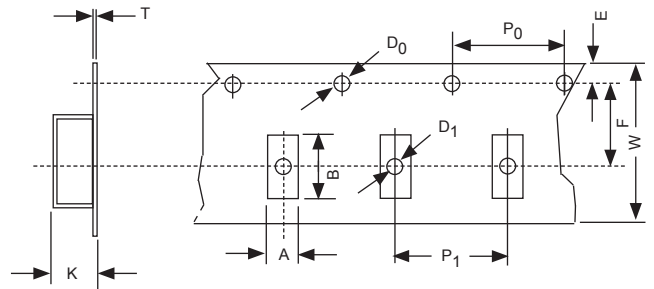

### REEL DIMENSIONS (mm) AND QUANTITY

Type	A	B	C	W	Quantity
NCSW100	180 +3/-0	60 +1/-0	13.0 ± 0.2	9.0 ± 0.3	4,000
NCSW200				17.0 ± 0.3	4,000

