

## FEATURES

- SURFACE MOUNTABLE 0402 ~ 2512 CASE SIZE
- PRECISION TOLERANCE ( $\pm 1\%$ )
- Pb-FREE REFLOW COMPATIBLE

## RoHS Compliant

includes all homogeneous materials

\*See Part Number System for Details

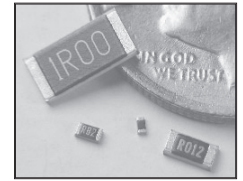

## CHARACTERISTICS

Type	EIA Size	Power Rating at 70°C	Resistance Tolerance	Temperature Coefficient (°C)	Resistance Range	Resistance Range (Codes)	Operating Temp. Range (°C)
NCST04	0402	1/16W	1% (F) 2% (G) 5% (J)	$\pm 200$ ppm (F)	501m $\Omega$ ~ 1 $\Omega$	R501 ~ 1R00	-55°C ~ +155°C
				$\pm 300$ ppm (G)	101m $\Omega$ ~ 500m $\Omega$	R101 ~ R500	
				$\pm 400$ ppm (H)	50m $\Omega$ ~ 100m $\Omega$	R050 ~ R100	
NCST06	0603	1/10W	1% (F) 2% (G) 5% (J)	$\pm 200$ ppm (F)	501m $\Omega$ ~ 1 $\Omega$	R501 ~ 1R00	
				$\pm 300$ ppm (G)	101m $\Omega$ ~ 500m $\Omega$	R101 ~ R500	
				$\pm 400$ ppm (H)	51m $\Omega$ ~ 100m $\Omega$	R051 ~ R100	
NCST10	0805	1/8W	1% (F) 2% (G) 5% (J)	$\pm 600$ ppm (J)	20m $\Omega$ ~ 50m $\Omega$	R020 ~ R050	
				$\pm 200$ ppm (F)	501m $\Omega$ ~ 1 $\Omega$	R501 ~ 1R00	
NCST12*	1206	1/4W	1% (F) 2% (G) 5% (J)	$\pm 300$ ppm (G)	51m $\Omega$ ~ 500m $\Omega$	R051 ~ R500	
NCST50*	2010	3/4W		$\pm 400$ ppm (H)	21m $\Omega$ ~ 50m $\Omega$	R021 ~ R050	
NCST100*	2512	1W		$\pm 600$ ppm (J)	10m $\Omega$ ~ 20m $\Omega$	R010 ~ R020	

\*Available with a  $\pm 100$ ppm (E) TCR (100m $\Omega$  ~ 1 $\Omega$ )

Item	Specification	Test Method
Temperature Coefficient of Resistance	As Specified	MIL-STD-202, Method 304 +25/-55/+25/+125/+25°C
Thermal Shock	$\pm(0.5\% + 0.05\Omega)$	MIL-STD-202, Method 107G -55°C ~ +125°C, 100 cycles
Short Time Overload	$\pm(0.5\% + 0.05\Omega)$	JIS-C-5202-5.5 RCWV x 2.5 or Max. Overloading Voltage for 5 sec.
Dielectric Withstanding Voltage	by Type	MIL-STD-202F Method 301 Apply Max. Overload Voltage for 1 minute
Insulation Resistance	>1000M $\Omega$	MIL-STD-202F Method 302 Apply 100Vdc for 1 minute
Resistance to dry heat	$\pm(0.5\% + 0.05\Omega)$	JIS-C-5202-7.2 96 hrs @ 125°C without load
Load Life	$\pm(1\% + 0.05\Omega)$	MIL-STD-202 Method 108 RCWV @ 70°C, cycles of 1.5 hours ON, 0.5 hrs OFF for 1,000 ~ 1,048 hrs
Resistance to Soldering Heat	$\pm(0.5\% + 0.05\Omega)$	MIL-STD-202F Method 210E 260°C $\pm 5^\circ$ C for 10 sec. $\pm 1$ sec.
Humidity (Steady State)	$\pm(1\% + 0.05\Omega)$	MIL-STD-202 Method 103B 40°C, 90 ~ 95% RH, RCWV 1.5 hours ON, 0.5 hours OFF, total 1000 ~ 1048 hours
Low Temperature Operation	$\pm(0.5\% + 0.05\Omega)$	JIS-C-5202-7.1 1 hour -65°C followed by 45 minutes of RCWV
Solderability	95% min. coverage	MIL-STD-202F Method 208H 235°C $\pm 5^\circ$ C for 2 sec. $\pm 0.5$ sec.
Bending Strength	$\pm(0.5\% + 0.05\Omega)$	JIS-C-5202-6.1.4 Bending Amplitude 3mm for 10 seconds

## PART NUMBER SYSTEM

NCST10 F R501 F TR F

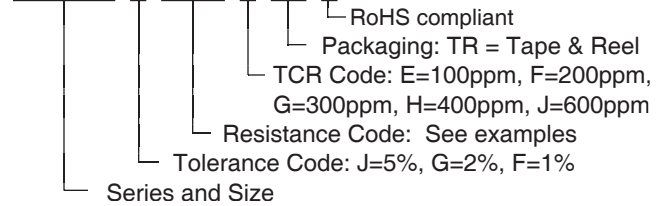

**Power Derating Curve:** For operation above 70°C, power rating must be derated according to the following chart:

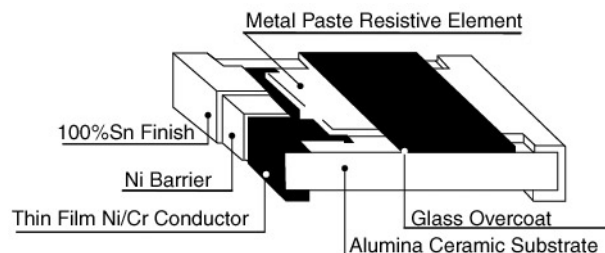
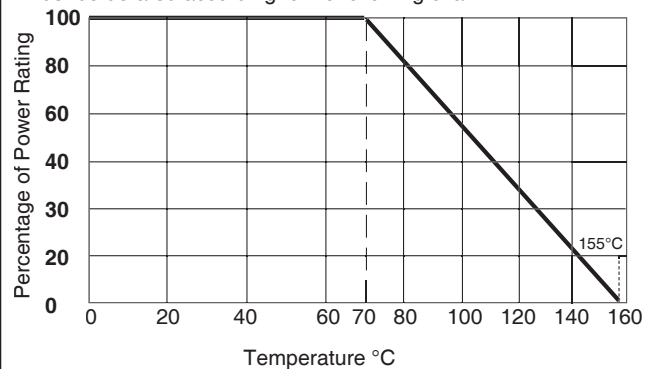

## RESISTANCE CODES

Milli-Ohm	Ohm	4-Digit-Code
10	0.010	R010
11	0.011	R011
12	0.012	R012
13	0.013	R013
14	0.014	R014
↓	↓	↓
200	0.200	R200
↓	↓	↓
300	0.300	R300
↓	↓	↓
400	0.400	R400
↓	↓	↓
500	0.500	R500
↓	↓	↓
600	0.600	R600
↓	↓	↓
700	0.700	R700
↓	↓	↓
800	0.800	R800
↓	↓	↓
900	0.900	R900
↓	↓	↓
1,000	1.000	1R00

Example: 543 milli-ohm = R543

## DIMENSIONS (mm)

Type	Length (L)	Width (W)	Thickness (T)	Termination Width (P <sub>1</sub> )	Termination Width (P <sub>2</sub> )
NCST04	1.00 ±0.05	0.50 ±0.05	0.32 ±0.05	0.25 ±0.10	0.20 ±0.10
NCST06	1.60 ±0.10	0.80 ±0.10	0.45 ±0.10	0.30 ±0.20	0.30 ±0.20
NCST10	2.00 ±0.10	1.25 ±0.10	0.50 ±0.10	0.30 ±0.20	0.30 ±0.20
NCST12	3.10 ±0.15	1.55 ±0.15	0.60 ±0.10	0.50 ±0.20	0.40 ±0.20
NCST50	5.00 ±0.15	2.50 ±0.15	0.60 ±0.10	0.60 ±0.30	0.50 ±0.25
NCST100	6.30 ±0.15	3.10 ±0.15	0.60 ±0.10	0.60 ±0.30	0.50 ±0.25

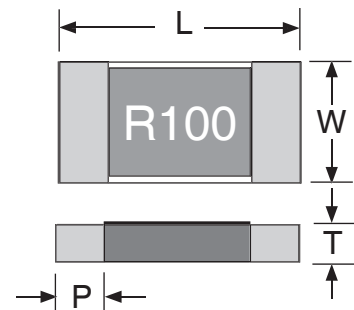

## LAND PATTERN DIM. (mm)

	A	B	C
NCST04	0.50	0.50	0.60 ±0.2
NCST06	0.70	0.80	0.90 ±0.2
NCST10	1.00	1.00	1.35 ±0.2
NCST12	1.15	2.00	1.70 ±0.2
NCST50	1.40	3.60	2.40 ±0.2
NCST100	1.60	4.9	3.00 ±0.2

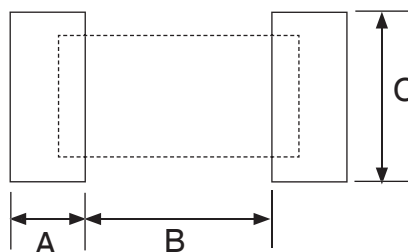

## PAPER CARRIER TAPE DIMENSIONS (mm)

Type	A	B	W	F	E	P <sub>1</sub>	P <sub>2</sub>	P <sub>0</sub>	φD	T
NCST04	0.67 ±0.03	1.15 ±0.03	8.00 ±0.10	3.50 ±0.05	1.75 ±0.05	2.00 ±0.05	2.00 ±0.05	4.00 ±0.10	1.55 ±0.05	0.40 ±0.03
NCST06	1.10 ±0.05	1.90 ±0.05				0.60 ±0.03				
NCST10	1.60 ±0.05	2.37 ±0.05				0.75 ±0.05				
NCST12	2.00 ±0.05	3.55 ±0.05								

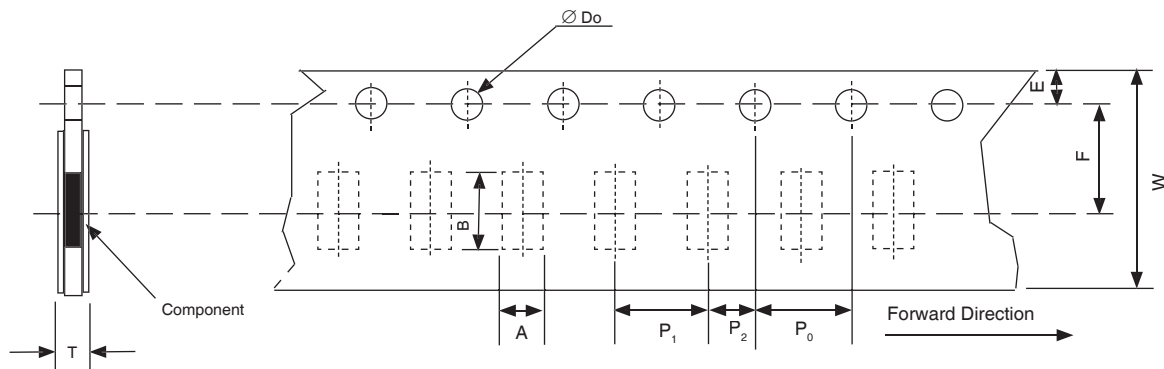

## EMBOSSED PLASTIC CARRIER DIMENSIONS (mm)

Type	A	B	W	F	E	P <sub>1</sub>	P <sub>2</sub>	P <sub>0</sub>	φD <sub>o</sub>	T
NCST50	2.85 ±0.10	5.45 ±0.10	12.00 ±0.10	5.50 ±0.05	1.75 ±0.10	4.00 ±0.05	2.00 ±0.05	4.00 ±0.05	1.50 ±0.05	0.80 ±0.10
NCST100	3.40 ±0.20	6.65 ±0.10								

## REEL DIMENSIONS (mm) AND QUANTITY

Type	A	B	C	W	Quantity
NCST04	178 ±1.0	60 +0.5	13 ±0.20	9.0 ±0.50	10,000
NCST06					5,000
NCST10					
NCST12					
NCST50				3.2 ±1.50	4,000
NCST100					

