

R SERIES**FEATURES**

- **High Temperature Durability**

No solder is used in connecting the cathode terminal to the tantalum pellet. Consequently, users can apply direct soldering (wave soldering) and reflow soldering.

- **High Adaptability of Automatic Assembly**

Tape and reel packaging is available in all product lines.

Precise dimensions due to transfer molded encapsulation provides excellent adaptability to automatic placement machines. 8 mm width carrier tape packaging, which is used extensively in most machines, is available for capacitors up to 150 μ F (B2 Case).

The A Case has the same dimensions (3.2 mm \times 1.6 mm) as chip resistors and ceramic capacitors.

The A2 Case has the same dimensions (3.2 mm \times 1.6 mm \times 1.2 mm MAX.) as mini mold Tr.

- **Wide Operating Temperature Range**

The R Series operating temperature range is -55°C to $+125^{\circ}\text{C}$.

PERFORMANCE CHARACTERISTICS

Item		Specification										Test Method
Operating Temperature Range		-55 to +125°C										
Rated Voltage		2.5	4	6.3	10	16	20	25	35	50	Vdc	Temperature: 85°C
Surge Voltage		3.3	5.2	8	13	20	26	33	46	65	Vdc	Temperature: 85°C
Category Voltage		1.6	2.5	4	6.3	10	13	16	22	32	Vdc	Temperature: 125°C (*1)
Capacitance Range		0.047 to 470 μ F										Frequency: 120 Hz
Capacitance Tolerance		\pm 20% (\pm 10%)										
Leakage Current (L.C.)		0.01 CV (μ A) or 0.5 μ A whichever is greater										5 min, after rated voltage applied
Tangent of Loss Angle (tan δ)	Standard	0.047 to 4.7 μ F: 0.04 max. 6.8 to 68 μ F : 0.06 max.										Frequency: 120 Hz
	Extended	2.5 to 10 V : 0.08 max. 16 to 35 V : 0.06 max. (*2)										
Equivalent Series Resistance (ESR)		Refer to standard ratings										Frequency: 100 kHz
Surge Voltage Rest		Δ C/C : \pm 5% (*3) tan δ : Initial Requirement L.C. : Initial Requirement										Temperature: 85°C Surge Voltage for 30 sec. Series Resistance: 1 k Ω Discharging Voltage for 5 min. 30 sec. 1000 cycles
Characteristics at High and Low Temperature	Temp.	-55°C			+85°C			+125°C				Step 1: 20°C Step 2: -55°C Step 3: 20°C Step 4: 85°C Step 5: 125°C Step 6: 20°C
	Δ C/C	0, -12%			+12, 0%			+15, 0%				
	tan δ	[Standard] (*4) 0.47 to 4.7 μ F: 0.08 max. 6.8 to 68 μ F: 0.1 max. [Extended] (*5) 2.5 to 10 V: 0.12 max. 16 to 35 V: 0.1 max.			Initial Requirement			[Standard] 0.47 to 4.7 μ F: 0.06 max. 6.8 to 68 μ F: 0.08 max. [Extended] (*6) 2.5 to 10 V: 0.1 max. 16 to 35 V: 0.08 max.				
	L.C.	-			0.1CV or 5 μ A whichever is greater			0.125CV or 6.25 μ A whichever is greater				
Rapid Change of Temperature		Δ C/C : \pm 5% (*3) tan δ : Initial Requirement L.C. : Initial Requirement										-55 to +125°C 5 cycles
Resistance to Soldering Heat		Δ C/C : \pm 5% (*3) tan δ : Initial Requirement L.C. : Initial Requirement										Fully immersion to solder, 260°C, 5 sec.
Damp Heat, Steady State		Δ C/C : \pm 5% (*3) tan δ : Initial Requirement \times 1.5 L.C. : Initial Requirement										Temperature: 40°C 90 to 95% RH 500 hours
Endurance		Δ C/C : \pm 10% (*3) tan δ : Initial Requirement L.C. : Initial Requirement \times 1.25										Temperature: 85°C Rated voltage applied Temperature: 125°C Category voltage applied for 2000 hours
Failure Rate		$\lambda_0 = 1\%/1000H$										

LEGEND

CV : Product of capacitance in μ F and voltage in V Δ C/C: Capacitance change ratio

*1: Category voltage at 85°C or more is calculated by following expression.

$$U_T = U_R - \frac{U_R - U_C}{40} (T - 85)$$

U_R : rated voltage

U_C : category voltage at 125°C

*2: tan δ of the specific products of R Series Extended is shown in the following table.

Product	tan δ
A case : 4 V/33 μF, 6.3 V/22 μF C case : 4 V/150 μF, 6.3 V/100 μF D2 case : 6.3 V/150 μF, 10 V/100 μF D case : 10 V/150 μF, 16 V/100 μF	0.10 max.
A2 case : 2.5 V/15 μF, 22 μF, 4 V/10 μF, 15 μF A case : 2.5 V/47 μF B3 case : 2.5 V/47 μF, 4 V/33 μF, 6.3 V/22 μF C case : 2.5 V/220 μF D2 case : 4 V/220 μF D case : 6.3 V/220 μF	0.12 max.
D2 case : 2.5 V/330 μF D case : 2.5 V/470 μF, 4 V/330 μF	0.14 max.

*3: The specific products of R series Extended in the following table are applied to capacitance change of ±12% or ±15% .

ΔC/C	Case Code	Product
±12%	A2	2.5 V/4.7 μF to 22 μF, 4 V/4.7 μF, 6.3 V/3.3 μF to 10 μF, 10 V/2.2 μF to 4.7 μF, 16 V/1.5 μF, 2.2 μF, 20 V/1 μF, 1.5 μF
	A	2.5 V/15 μF to 47 μF, 4 V/10 μF to 33 μF, 6.3 V/6.8 μF to 22 μF, 10 V/4.7 μF to 10 μF, 16 V/3.3 μF to 6.8 μF, 20 V/2.2 μF to 4.7 μF, 25 V/1.5 μF, 2.2 μF, 35 V/1 μF, 1.5 μF
	B2	2.5 V/33 μF to 100 μF
	C	2.5 V/220 μF, 4 V/150 μF, 6.3 V//100 μF, 10 V/68 μF, 16 V/47 μF
	D2	2.5 V/330 μF, 4 V/220 μF, 6.3 V/150 μF, 10 V/100 μF
	D	2.5 V/470 μF, 4 V/330 μF, 6.3 V/220 μF, 10 V/150 μF, 16 V/100 μF
±15%	B3	All Items

*4: The following products of R-series Standard are applied to tan δ of 0.12

4 V/3.3 μF, 4.7 μF, 10 μF, 22 μF, 33 μF, 68 μF, 6.3 V/3.3 μF, 10 V/2.2 μF

*5 : $\tan \delta$ of the specific products of R-series Extended is shown in the following table

Product	$\tan \delta$
A case : 4 V/33 μ F, 6.3 V/22 μ F, 10 V/15 μ F B2 case : 2.5 V/100 μ F C case : 4 V/150 μ F, 6.3 V/100 μ F D2 case : 6.3 V/150 μ F, 10 V/100 μ F	0.14 max.
A2 case : 2.5 V/15 μ F, 4 V/10 μ F C case : 2.5 V/ 220 μ F	0.16 max.
B3 case : 2.5 V/47 μ F, 4 V/33 μ F, 6.3 V/22 μ F D2 case : 2.5 V/330 μ F, 4 V/220 μ F D case : 2.5 V/470 μ F, 4 V/330 μ F, 6.3 V/220 μ F, 10 V/150 μ F, 16 V/100 μ F	0.18 max.
A2 case : 4 v/15 μ F	0.20 max.
A2 case : 2.5 V/22 μ F A case : 2.5 V/47 μ F	0.22 max.

*6 : $\tan \delta$ of the specific products of R Series Extended is shown in the following table

Product	$\tan \delta$
A case : 4 V/33 μ F, 6.3 V/22 μ F C case : 4 V/150 μ F, 6.3 V/100 μ F D2 case : 6.3 V/150 μ F, 10 V/100 μ F D case : 10 V/150 μ F, 16 V/100 μ F	0.12 max.
A2 case : 2.5V/15 μ F, 4 V/10 μ F, 4 V/15 μ F C case : 2.5 V/220 μ F D2 case : 4 V/220 μ F D case : 6.3 V/220 μ F	0.14 max.
B3 case : 2.5 V/47 μ F, 4 V/33 μ F, 6.3 V/22 μ F	0.15 max.
A case : 2.5 V/22 μ F A case : 2.5 V/47 μ F D2 case : 2.5 V/330 μ F D case : 2.5 V/470 μ F, 4 V/330 μ F	0.16 max.

OUTLINE DRAWINGS AND DIMENSIONS

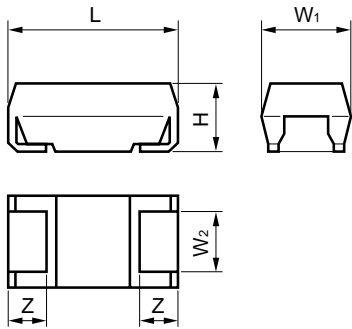

[A2, A & B3 cases]

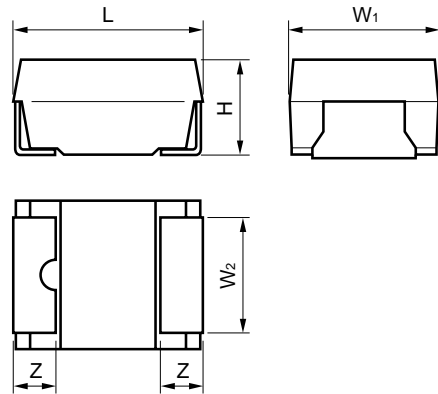

[B2 case]

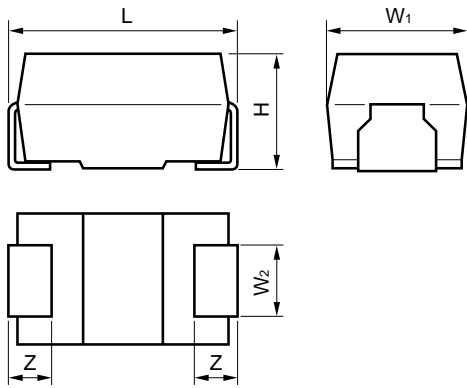

[D2 case]

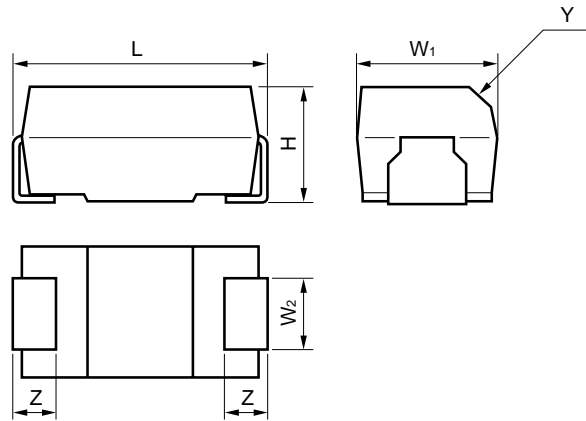

[B, C & D cases]

Unit : mm (inch)

Case Size (Case Code)	EIA Code	L	W ₁	W ₂	H	Z	Y
A2 (U)	3216L	3.2±0.2 (0.126±0.008)	1.6±0.2 (0.063±0.008)	1.2±0.1 (0.047±0.004)	1.2 MAX. (0.047 MAX.)	0.8±0.3 (0.031±0.012)	—
A	3216	3.2±0.2 (0.126±0.008)	1.6±0.2 (0.063±0.008)	1.2±0.1 (0.047±0.004)	1.6±0.2 (0.063±0.008)	0.8±0.3 (0.031±0.012)	—
B3 (W)	3528L	3.5±0.2 (0.138±0.008)	2.8±0.2 (0.110±0.008)	2.2±0.1 (0.087±0.004)	1.2 MAX. (0.047 MAX.)	0.8±0.3 (0.031±0.012)	—
B2 (S)	3528	3.5±0.2 (0.138±0.008)	2.8±0.2 (0.110±0.008)	2.3±0.1 (0.091±0.004)	1.9±0.2 (0.075±0.008)	0.8±0.3 (0.031±0.012)	—
B	—	4.7±0.3 (0.185±0.012)	2.6±0.3 (0.102±0.012)	1.4±0.1 (0.055±0.004)	2.1±0.3 (0.083±0.012)	0.8±0.3 (0.031±0.012)	C0.4 (0.016)
C	6032	6.0±0.3 (0.236±0.012)	3.2±0.3 (0.126±0.012)	2.2±0.1 (0.087±0.004)	2.5±0.3 (0.098±0.012)	1.3±0.3 (0.051±0.012)	C0.4 (0.016)
D2 (T)	—	5.8±0.3 (0.228±0.012)	4.6±0.2 (0.181±0.012)	2.4±0.1 (0.094±0.004)	3.2±0.3 (0.126±0.012)	1.3±0.3 (0.051±0.012)	—
D	7343	7.3±0.2 (0.287±0.012)	4.3±0.2 (0.169±0.008)	2.4±0.1 (0.094±0.004)	2.8±0.3 (0.110±0.012)	1.3±0.3 (0.051±0.012)	C0.5 (0.020)

MARKING

[A2 & A Case]

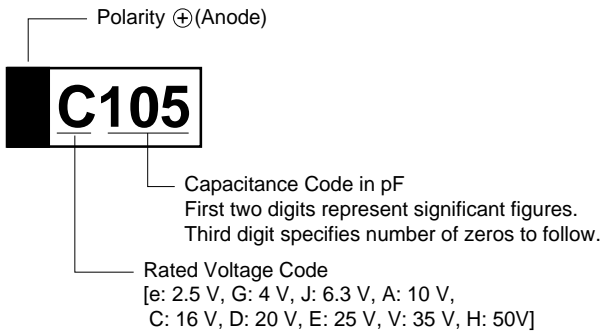

[B Case]

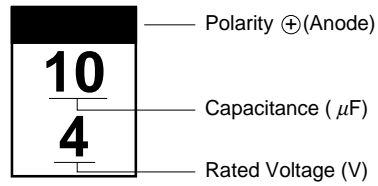

[C & D Case]

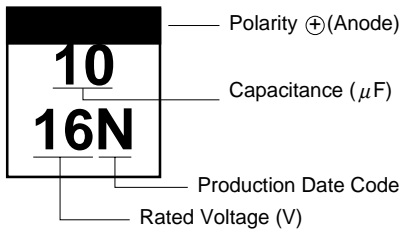

[B3, B2 & D2 Case]

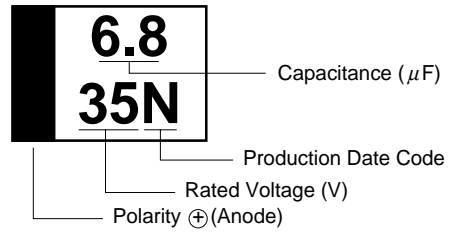

[Marking of Production Date Code]

Month Year	Jan.	Feb.	Mar.	Apr.	May	Jun.	Jul.	Aug.	Sep.	Oct.	Nov.	Dec.
1998	N	P	Q	R	S	T	U	V	W	X	Y	Z
1999	a	b	c	d	e	f	g	h	j	k	l	m
2000	n	p	q	r	s	t	u	v	w	x	y	z
2001	A	B	C	D	E	F	G	H	J	K	L	M

Date code will resume beginning in 2002.

PRODUCT LINE-UP AND CASE SIZE

R SERIES STANDARD

Rated Voltage (Vdc) Capacitance (μ F)	4	6.3	10	16	20	25	35	50
0.010								
0.015								
0.022								
0.033								
0.047							A	
0.068							A	
0.10							A	A
0.15							A	A
0.22							A	B2
0.33							A	B2
0.47						A	B2 B	B2
0.68					A		B2 B	C
1.0				A			B2 B	C
1.5			A	A		B2 B	C	C
2.2		A	A		B2 B		C	D
3.3	A	A		B2 B		C	C D	D2 D
4.7	A		B2 B		C	C	D2 D	D
6.8		B2 B		C	C	D2 D	D2 D	
10	B2 B		C	C	D2 D	D2 D		
15		C	C	D2 D	D2 D			
22	C	C	D2 D	D2 D				
33	C	D2 D	D2 D					
47	D2 D	D2 D						
68	D2 D							

R SERIES EXTENDED

Rated Voltage (Vdc) / Capacitance (μ F)	2.5	4	6.3	10	16	20	25	35
0.1						A2		
0.15						A2		
0.22						A2		
0.33						A2		
0.47						A2		A
0.68					A2	A2	A	A
1				A2	A2	A2 A	A	A
1.5			A2	A2	A2	A2 A	A	A B2 B
2.2		A2	A2	A2	A2 A	A	A B2	B2 B
3.3		A2	A2	A2 A	A	A B2	B2 B	B2
4.7	A2	A2	A2 A	A2 A	A B2	A B2 B	B2	C
6.8	A2	A2 A	A2 A	A B2	A B3 B2 B	B2	C	C
10	A2	A2 A	A2 A B2	A B3 B2 B	B2	B2 C	C	D2 D
15	A2 A	A2 A B2	A B3 B2 B	B2	B2 C	C	D2 D	D
22	A2 A	A B3 B2 B	A B3 B2	B2 C	B2 C	C D2 D	D	
33	A B3 B2	A B3 B2	B2 C	B2 C	C D2 D	D2 D		
47	A B3 B2	B2 C	B2 C	C D2 D	C D2 D	D		
68	B2	B2 C	B2 C D2 D	C D2 D	D			
100	B2	B2 C D2 D	C D2 D	D2 D	D			
150	B2	C D2 D	D2 D	D				
220	C	D2 D	D					
330	D2	D						
470	D							

PART NUMBERING SYSTEM

— Bulk —

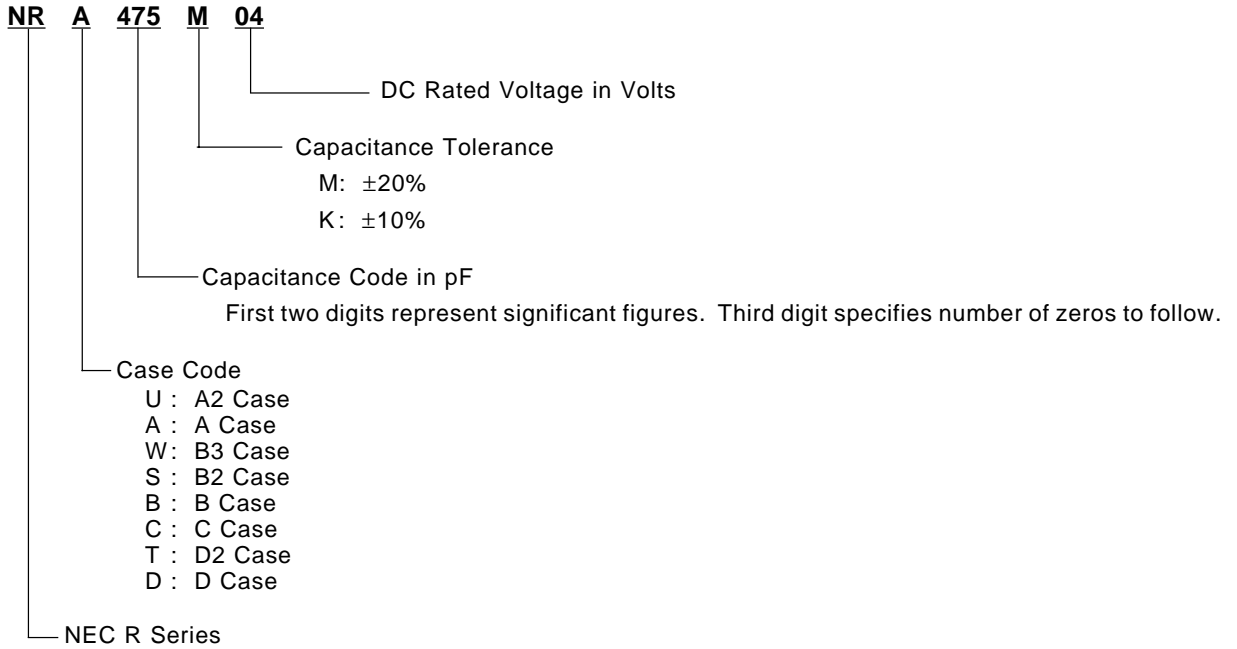

— Tape and Reel —

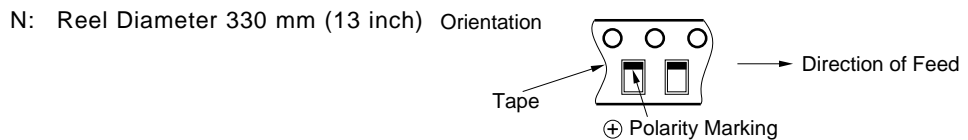
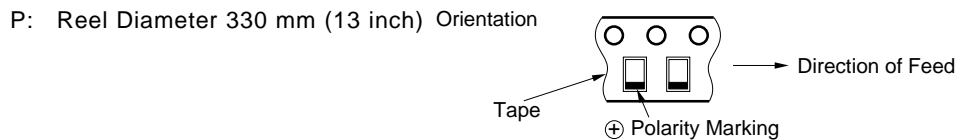
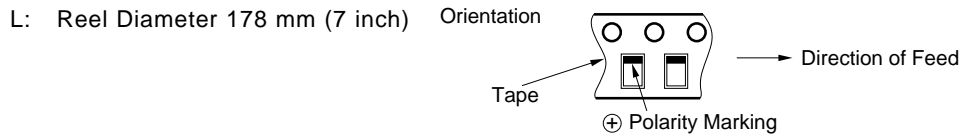
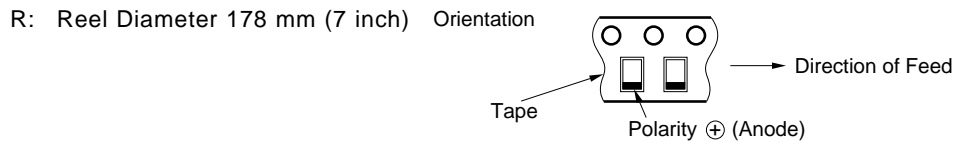
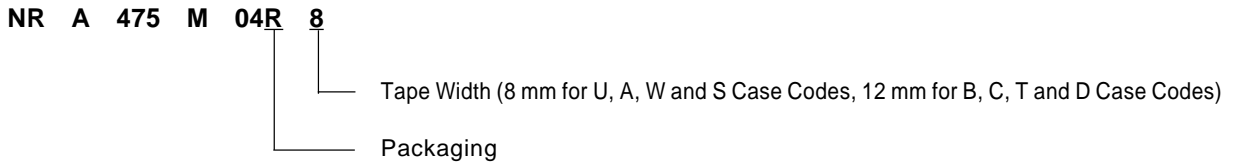

RATINGS

STANDARD

DC Rated Voltage @85°C (125°C) V	Capacitance @20°C, 120 Hz μF	Case Size (Case Code)	Part Number	Leakage Current @20°C μA Max.	tan δ @20°C, 120 Hz % Max.	ESR @20°C, 100 kHz Ω Max.
4 (2.5)	3.3	A	NRA335M04	0.5	4	8.0
	4.7	A	NRA475M04	0.5	4	7.5
	10	B2(S)	NRS106M04	0.5	6	3.5
	10	B	NRB106M04	0.5	6	3.5
	22	C	NRC226M04	0.8	6	1.8
	33	C	NRC336M04	1.3	6	1.8
	47	D2(T)	NRT476M04	1.9	6	1.2
	47	D	NRD476M04	1.9	6	1.2
	68	D2(T)	NRT686M04	2.7	6	0.8
	68	D	NRD686M04	2.7	6	0.8
6.3 (4)	2.2	A	NRA225M06	0.5	4	8.0
	3.3	A	NRA335M06	0.5	4	7.0
	6.8	B2(S)	NRS685M06	0.5	6	3.5
	6.8	B	NRB685M06	0.5	6	3.5
	15	C	NRC156M06	0.9	6	1.8
	22	C	NRC226M06	1.4	6	1.8
	33	D2(T)	NRT336M06	2.0	6	1.5
	33	D	NRD336M06	2.0	6	1.5
	47	D2(T)	NRT476M06	3.0	6	1.1
	47	D	NRD476M06	3.0	6	0.8
10 (6.3)	1.5	A	NRA155M10	0.5	4	8.0
	2.2	A	NRA225M10	0.5	4	7.0
	4.7	B2(S)	NRS475M10	0.5	4	3.5
	4.7	B	NRB475M10	0.5	4	3.5
	10	C	NRC106M10	1.0	6	1.8
	15	C	NRC156M10	1.5	6	1.8
	22	D2(T)	NRT226M10	2.2	6	1.5
	22	D	NRD226M10	2.2	6	1.5
	33	D2(T)	NRT336M10	3.3	6	1.1
	33	D	NRD336M10	3.3	6	0.8
16 (10)	1	A	NRA105M16	0.5	4	10
	1.5	A	NRA155M16	0.5	4	8.0
	3.3	B2(S)	NRS335M16	0.5	4	3.5
	3.3	B	NRB335M16	0.5	4	4.5
	6.8	C	NRC685M16	1.0	6	1.9
	10	C	NRC106M16	1.6	6	1.8
	15	D2(T)	NRT156M16	2.4	6	1.5
	15	D	NRD156M16	2.4	6	1.5
	22	D2(T)	NRT226M16	3.5	6	1.1
	22	D	NRD226M16	3.5	6	0.8

Note Part numbers in the tables above are for products with a capacitance tolerance of ±20%. For products with a capacitance tolerance of ±10%, change the letter “M” to “K”.

Use the letters “S” and “T” in part numbers for the case code “B2” and “D2”.

Please refer to page 41 for the detail of part numbering system.

DC Rated Voltage @85°C (125°C) V	Capacitance @20°C, 120 Hz μF	Case Size (Case Code)	Part Number	Leakage Current @20°C μA Max.	tan δ @20°C, 120 Hz % Max.	ESR @20°C, 100 kHz Ω Max.
20 (13)	0.68	A	NRA684M20	0.5	4	12
	2.2	B2(S)	NRS225M20	0.5	4	3.5
	2.2	B	NRB225M20	0.5	4	5
	4.7	C	NRC475M20	0.9	4	2.4
	6.8	C	NRC685M20	1.4	6	1.9
	10	D2(T)	NRT106M20	2.0	6	1.5
	10	D	NRD106M20	2.0	6	1.3
	15	D2(T)	NRT156M20	3.0	6	1.1
25 (16)	0.47	A	NRA474M25	0.5	4	14
	1.5	B2(S)	NRS155M25	0.5	4	4.6
	1.5	B	NRB155M25	0.5	4	10
	3.3	C	NRC335M25	0.8	4	2.5
	4.7	C	NRC475M25	1.1	4	2.4
	6.8	D2(T)	NRT685M25	1.7	6	1.5
	6.8	D	NRD685M25	1.7	6	1.4
	10	D2(T)	NRT106M25	2.5	6	1.2
35 (22)	0.047	A	NRA473M35	0.5	4	40
	0.068	A	NRA683M35	0.5	4	40
	0.1	A	NRA104M35	0.5	4	18
	0.15	A	NRA154M35	0.5	4	18
	0.22	A	NRA224M35	0.5	4	18
	0.33	A	NRA334M35	0.5	4	15
	0.47	B2(S)	NRS474M35	0.5	4	8.0
	0.47	B	NRB474M35	0.5	4	12
	0.68	B2(S)	NRS684M35	0.5	4	5.4
	0.68	B	NRB684M35	0.5	4	10
	1	B2(S)	NRS105M35	0.5	4	4.8
	1	B	NRB105M35	0.5	4	10
	1.5	C	NRC155M35	0.5	4	3.0
	2.2	C	NRC225M35	0.7	4	3.0
	3.3	C	NRC335M35	1.2	4	2.5
	3.3	D	NRD335M35	1.2	4	2.0
	4.7	D2(T)	NRT475M35	1.6	4	1.5
4.7	D	NRD475M35	1.6	4	1.5	
6.8	D2(T)	NRT685M35	2.3	6	1.3	
6.8	D	NRD684M35	2.3	6	1.3	
50 (32)	0.1	A	NRA104M50	0.5	4	20
	0.15	A	NRA154M50	0.5	4	19
	0.22	B2(S)	NRS224M50	0.5	4	14
	0.33	B2(S)	NRS334M50	0.5	4	10
	0.47	B2(S)	NRS474M50	0.5	4	9.0
	0.68	C	NRC684M50	0.5	4	7.0
	1	C	NRC105M50	0.5	4	5.5
	1.5	C	NRC155M50	0.7	4	4.0
	2.2	D	NRD225M50	1.1	4	2.0
	3.3	D2(T)	NRT335M50	1.6	4	2.0
	3.3	D	NRD335M50	1.6	4	1.8
4.7	D	NRD475M50	2.3	4	1.4	

Note Part numbers in the tables above are for products with a capacitance tolerance of $\pm 20\%$. For products with a capacitance tolerance of $\pm 10\%$, change the letter "M" to "K".

Use the letters "S" and "T" in part numbers for the case code "B2" and "D2".

Please refer to page 41 for the detail of part numbering system.

EXTENDED

DC Rated Voltage @85°C (125°C) V	Capacitance @20°C, 120 Hz μF	Case Size (Case Code)	Part Number	Leakage Current @20°C μA Max.	tan δ @20°C, 120 Hz % Max.	ESR @20°C, 100 kHz Ω Max.
2.5 (1.6)	4.7	A2(U)	NRU475M02	0.5	8	18
	6.8	A2(U)	NRU685M02	0.5	8	16
	10	A2(U)	NRU106M02	0.5	8	15
	15	A2(U)	NRU156M02	0.5	12	10
	15	A	NRA156M02	0.5	8	5.0
	22	A2(U)	NRU226M02	0.5	12	10
	22	A	NRA226M02	0.5	8	4
	33	A	NRA336M02	0.8	8	3.5
	33	B3(W)	NRW336M02	0.8	8	—
	33	B2(S)	NRS336M02	0.8	8	3.0
	47	A	NRA476M02	1.1	12	4.5
	47	B3(W)	NRW476M02	1.1	12	—
	47	B2(S)	NRS476M02	1.1	8	2.4
	68	B2(S)	NRS686M02	1.7	8	2.0
	100	B2(S)	NRS107M02	2.5	8	2.0
	150	B2(S)	NRS157M02	3.7	16	—
	220	C	NRC227M02	5.5	12	1.0
	330	D2(T)	NRT337M02	8.2	14	0.7
	470	D	NRD477M02	11.7	14	0.7
	4 (2.5)	2.2	A2(U)	NRU225M04	0.5	8
3.3		A2(U)	NRA335M04	0.5	8	18
4.7		A2(U)	NRU475M04	0.5	8	10
6.8		A2(U)	NRU685M04	0.5	8	8.0
6.8		A	NRA685M04	0.5	8	6.0
10		A2(U)	NRU106M04	0.5	12	8.0
10		A	NRA106M04	0.5	8	5.0
15		A2(U)	NRU156M04	0.6	12	8.0
15		A	NRA156M04	0.6	8	4.0
15		B2(S)	NRS156M04	0.6	8	3.0
22		A	NRA226M04	0.8	8	3.5
22		B3(W)	NRW226M04	0.8	8	—
22		B2(S)	NRS226M04	0.8	8	2.8
22		B	NRB226M04	0.8	8	3.0
33		A	NRA336M04	1.3	10	4.5
33		B3(W)	NRW336M04	1.3	12	—
33		B2(S)	NRS336M04	1.3	8	2.4
47		B2(S)	NRS476M04	1.8	8	2.0
47		C	NRC476M04	1.8	8	1.8
68		B2(S)	NRS686M04	2.7	8	2.0
68		C	NRC686M04	2.7	8	1.6
100		B2(S)	NRS107M04	4.0	12	—
100		C	NRC107M04	4.0	8	1.2
100		D2(T)	NRT107M04	4.0	8	0.9
100		D	NRD107M04	4.0	8	0.8
150		C	NRC157M04	6.0	10	1.0
150		D2(T)	NRT157M04	6.0	8	0.7
150		D	NRD157M04	6.0	8	0.7
220		D2(T)	NRT227M04	8.8	12	0.7
220		D	NRD227M04	8.8	8	0.7
330	D	NRD337M04	13.2	14	0.7	

Note Part numbers in the tables above are for products with a capacitance tolerance of ±20%. For products with a capacitance tolerance of ±10%, change the letter “M” to “K”.

Use the letters “U”, “W”, “S” and “T” in part numbers for the case code “A2”, “B3”, “B2” and “D2”.

Please refer to page 41 for the detail of part numbering system.

DC Rated Voltage @85°C (125°C) V	Capacitance @20°C, 120 Hz μF	Case Size (Case Code)	Part Number	Leakage Current @20°C μA Max.	tan δ @20°C, 120 Hz % Max.	ESR @20°C, 100 kHz Ω Max.
6.3 (4)	1.5	A2(U)	NRU155M06	0.5	8	25
	2.2	A2(U)	NRU225M06	0.5	8	18
	3.3	A2(U)	NRU335M06	0.5	8	9.0
	4.7	A2(U)	NRU475M06	0.5	8	7.5
	4.7	A	NRA475M06	0.5	8	6.0
	6.8	A2(U)	NRU685M06	0.5	8	7.5
	6.8	A	NRA685M06	0.5	8	5.0
	10	A2(U)	NRU106M06	0.6	8	10
	10	A	NRA106M06	0.6	8	4.0
	10	B2(S)	NRS106M06	0.6	8	3.0
	15	A	NRA156M06	0.9	8	3.5
	15	B3(W)	NRW156M06	0.9	8	—
	15	B2(S)	NRS156M06	0.9	8	2.5
	15	B	NRB156M06	0.9	8	3.0
	22	A	NRA226M06	1.4	10	4.5
	22	B3(W)	NRW226M06	1.4	12	—
	22	B2(S)	NRS226M06	1.4	8	2.3
	33	B2(S)	NRS336M06	2.0	8	2.0
	33	C	NRC336M06	2.0	8	1.8
	47	B2(S)	NRS476M06	3.0	8	2.0
	47	C	NRC476M06	3.0	8	1.6
	68	B2(S)	NRS686M06	4.2	10	—
	68	C	NRC686M06	4.2	8	1.2
	68	D2(T)	NRT686M06	4.2	8	0.9
	68	D	NRD686M06	4.2	8	0.8
	100	C	NRC107M06	6.3	10	0.9
	100	D2(T)	NRT107M06	6.3	8	0.8
	100	D	NRD107M06	6.3	8	0.8
	150	D2(T)	NRT157M06	9.4	10	0.8
	150	D	NRD157M06	9.4	8	0.8
220	D	NRD227M06	13.8	12	0.8	
10 (6.3)	1	A2(U)	NRU105M10	0.5	8	25
	1.5	A2(U)	NRU155M10	0.5	8	20
	2.2	A2(U)	NRU225M10	0.5	8	12
	3.3	A2(U)	NRU335M10	0.5	8	12
	3.3	A	NRA335M10	0.5	8	5.5
	4.7	A2(U)	NRU475M10	0.5	8	8.0
	4.7	A	NRA475M10	0.5	8	5.0
	6.8	A	NRA685M10	0.6	8	4.5
	6.8	B2(S)	NRS685M10	0.6	8	3.0
	10	A	NRA106M10	1.0	8	3.2
	10	B3(W)	NRW106M10	1.0	8	—
	10	B2(S)	NRS106M10	1.0	8	2.5
	10	B	NRB106M10	1.0	8	3.0
	15	B2(S)	NRS156M10	1.5	8	2.5
	22	B2(S)	NRS226M10	2.2	8	2.4
	22	C	NRC226M10	2.2	8	1.8
	33	B2(S)	NRS336M10	3.3	8	2.0
	33	C	NRC336M10	3.3	8	1.6

Note Part numbers in the tables above are for products with a capacitance tolerance of ±20%. For products with a capacitance tolerance of ±10%, change the letter “M” to “K”.

Use the letters “U”, “W”, “S” and “T” in part numbers for the case code “A2”, “B3”, “B2” and “D2”.

Please refer to page 41 for the detail of part numbering system.

DC Rated Voltage @85°C (125°C) V	Capacitance @20°C, 120 Hz μF	Case Size (Case Code)	Part Number	Leakage Current @20°C μA Max.	tan δ @20°C, 120 Hz % Max.	ESR @20°C, 100 kHz Ω Max.
10 (6.3)	47	C	NRC476M10	4.7	8	1.6
	47	D2(T)	NRT476M10	4.7	8	0.9
	47	D	NRD476M10	4.7	8	0.8
	68	C	NRC686M10	6.8	8	1.2
	68	D2(T)	NRT686M10	6.8	8	0.8
	68	D	NRD686M10	6.8	8	0.8
	100	D2(T)	NRT107M10	10	10	0.8
	100	D	NRD107M10	10	8	0.7
	150	D	NRD157M10	15	10	0.7
16 (10)	0.68	A2(U)	NRU684M16	0.5	6	25
	1	A2(U)	NRU105M16	0.5	6	16
	1.5	A2(U)	NRU155M16	0.5	6	13
	2.2	A2(U)	NRU225M16	0.5	6	13
	2.2	A	NRA225M16	0.5	6	6.0
	3.3	A	NRA335M16	0.5	6	5.0
	4.7	A	NRA475M16	0.7	6	5.0
	4.7	B2(S)	NRS475M16	0.7	6	3.0
	6.8	A	NRA685M16	1.0	6	5.0
	6.8	B3(W)	NRW685M16	1.0	6	—
	6.8	B2(S)	NRS685M16	1.0	6	2.5
	6.8	B	NRB685M16	1.0	6	3.5
	10	B2(S)	NRS106M16	1.6	6	2.4
	15	B2(S)	NRS156M16	2.4	6	2.5
	15	C	NRC156M16	2.4	6	1.8
	22	B2(S)	NRS226M16	3.5	6	2.5
	22	C	NRC226M16	3.5	6	1.6
	33	C	NRC336M16	5.2	6	1.2
	33	D2(T)	NRT336M16	5.2	6	0.9
	33	D	NRD336M16	5.2	6	0.8
	47	C	NRC476M16	7.5	6	1.2
	47	D2(T)	NRT476M16	7.5	6	0.8
	47	D	NRD476M16	7.5	6	0.8
	68	D	NRD686M16	10.8	6	0.7
100	D	NRD107M16	16	10	—	
20 (13)	0.1	A2(U)	NRU104M20	0.5	6	40
	0.15	A2(U)	NRU154M20	0.5	6	35
	0.22	A2(U)	NRU224M20	0.5	6	35
	0.33	A2(U)	NRU334M20	0.5	6	30
	0.47	A2(U)	NRU474M20	0.5	6	27
	0.68	A2(U)	NRU684M20	0.5	6	15
	1	A2(U)	NRU105M20	0.5	6	13
	1	A	NRA105M20	0.5	6	9.0
	1.5	A2(U)	NRU155M20	0.5	6	13
	1.5	A	NRA155M20	0.5	6	6.5
	2.2	A	NRA225M20	0.5	6	6.0
	3.3	A	NRA335M20	0.6	6	5.0
	3.3	B2(S)	NRS335M20	0.6	6	3.0
	4.7	A	NRA475M20	0.9	6	5.0
	4.7	B2(S)	NRS475M20	0.9	6	3.0

Note Part numbers in the tables above are for products with a capacitance tolerance of ±20%. For products with a capacitance tolerance of ±10%, change the letter "M" to "K".

Use the letters "U", "W", "S" and "T" in part numbers for the case code "A2", "B3", "B2" and "D2".

Please refer to page 41 for the detail of part numbering system.

DC Rated Voltage @85°C (125°C) V	Capacitance @20°C, 120 Hz μF	Case Size (Case Code)	Part Number	Leakage Current @20°C μA Max.	tan δ @20°C, 120 Hz % Max.	ESR @20°C, 100 kHz Ω Max.
20 (13)	4.7	B	NRB475M20	0.9	6	4.0
	6.8	B2(S)	NRS685M20	1.4	6	2.8
	10	B2(S)	NRS106M20	2.0	6	2.5
	10	C	NRC106M20	2.0	6	1.8
	15	C	NRC156M20	3.0	6	1.7
	22	C	NRC226M20	4.4	6	1.5
	22	D2(T)	NRT226M20	4.4	6	0.9
	22	D	NRD226M20	4.4	6	0.8
	33	D2(T)	NRT336M20	6.6	6	0.8
	33	D	NRD336M20	6.6	6	0.8
	47	D	NRD476M20	9.4	6	0.8
25 (16)	0.68	A	NRA684M25	0.5	6	10
	1	A	NRA105M25	0.5	6	8.0
	1.5	A	NRA155M25	0.5	6	8.0
	2.2	A	NRS225M25	0.5	6	8.0
	2.2	B2(S)	NRS225M25	0.5	6	4.0
	3.3	B2(S)	NRS335M25	0.8	6	3.5
	3.3	B	NRB335M25	0.8	6	4.5
	4.7	B2(S)	NRS475M25	1.1	6	3.0
	6.8	C	NRC685M25	1.7	6	1.9
	10	C	NRC106M25	2.5	6	1.8
	15	D2(T)	NRT156M25	3.7	6	1.2
	15	D	NRD156M25	3.7	6	1.0
	22	D	NRD226M25	5.5	6	0.8
35 (22)	0.47	A	NRA474M35	0.5	6	12
	0.68	A	NRA684M35	0.5	6	9.0
	1	A	NRA105M35	0.5	6	8.0
	1.5	A	NRA155M35	0.5	6	8.0
	1.5	B2(S)	NRS155M35	0.5	6	4.8
	1.5	B	NRB155M35	0.5	6	5.0
	2.2	B2(S)	NRS225M35	0.7	6	4.2
	2.2	B	NRB225M35	0.7	6	5.0
	3.3	B2(S)	NRS335M35	1.1	6	4.0
	4.7	C	NRC475M35	1.6	6	2.2
	6.8	C	NRC685M35	2.3	6	1.9
	10	D2(T)	NRT106M35	3.5	6	1.2
	10	D	NRD106M35	3.5	6	1.0
	15	D	NRD156M35	5.2	6	0.9

Note Part numbers in the tables above are for products with a capacitance tolerance of ±20%. For products with a capacitance tolerance of ±10%, change the letter “M” to “K”.

Use the letters “U”, “W”, “S” and “T” in part numbers for the case code “A2”, “B3”, “B2” and “D2”.

Please refer to page 41 for the detail of part numbering system.

- R Series (Standard)

Characteristics at High and Low Temperature

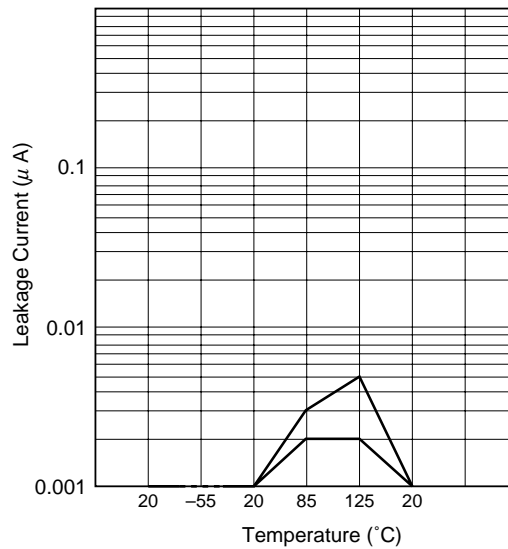
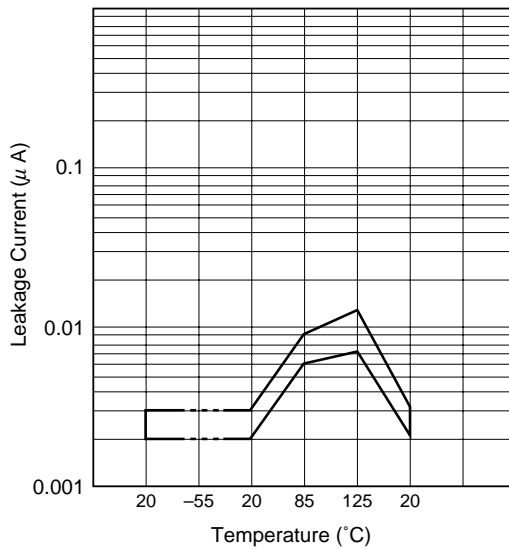
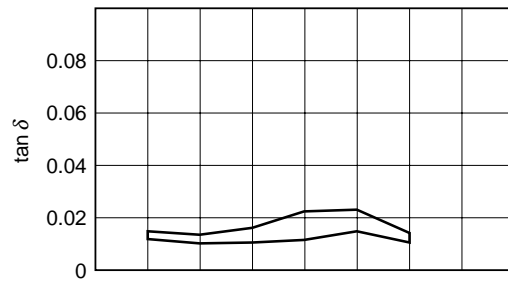
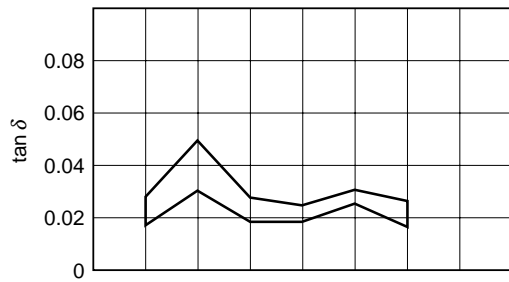
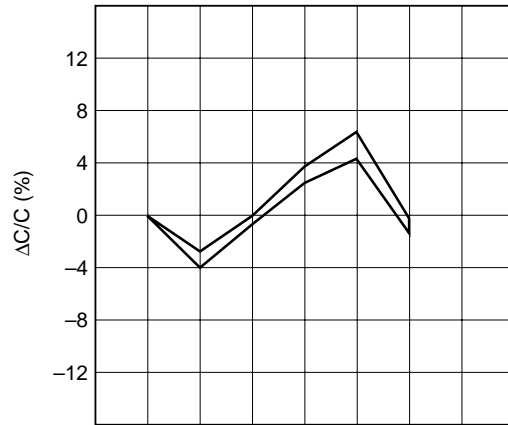
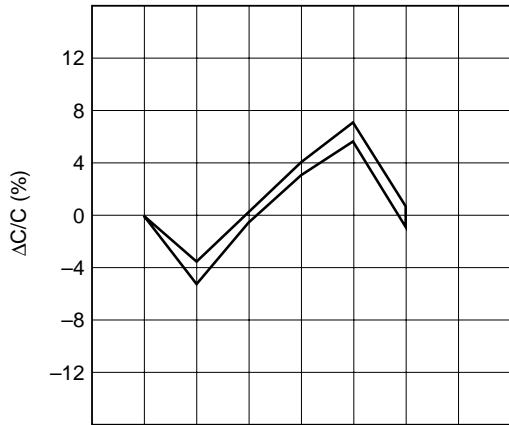

3.3 μF/4 V A Case

0.33 μF/35 V A Case

- R Series (Standard)

Characteristics at High and Low Temperature

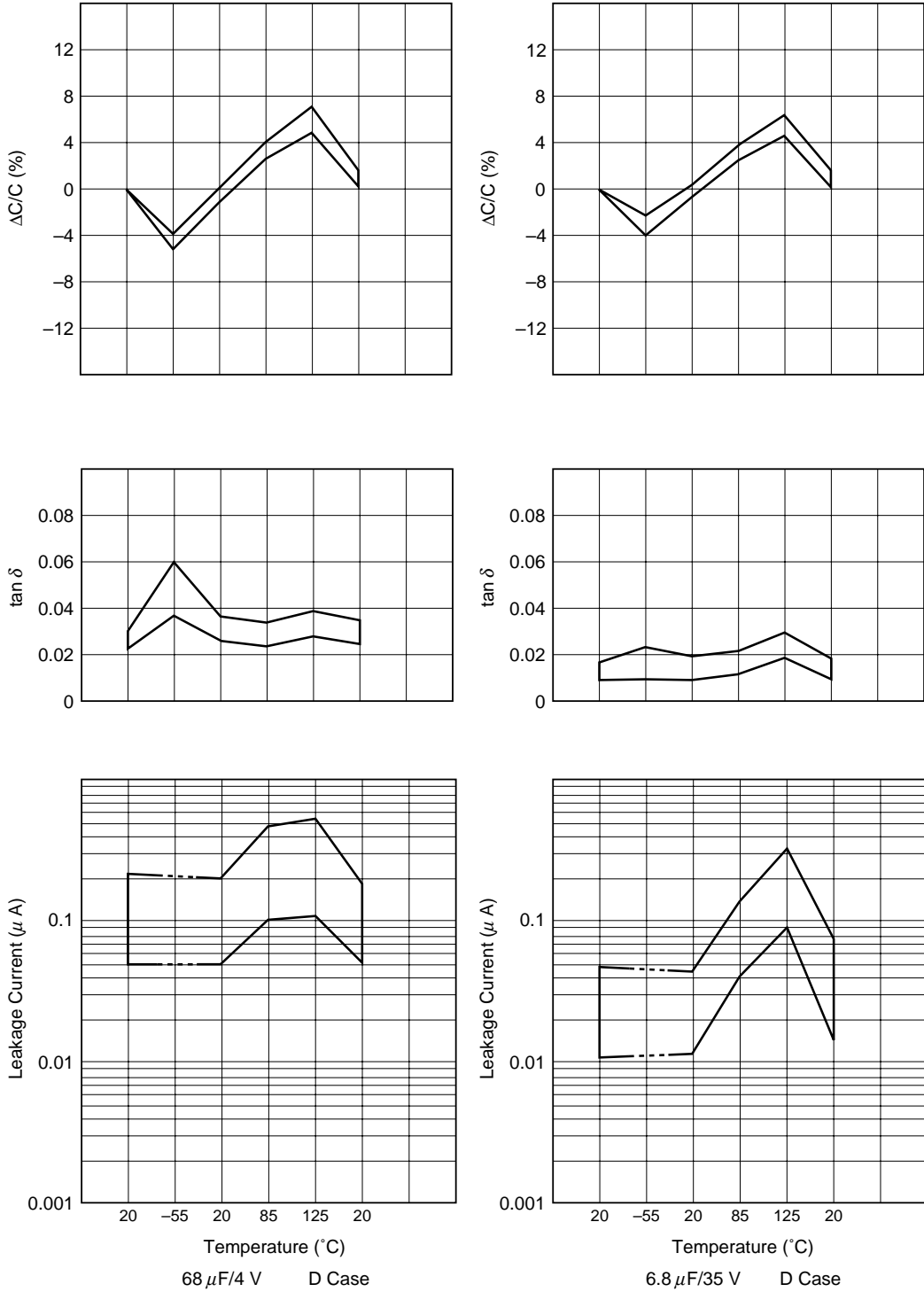

- R Series (Standard)

Resistance to Soldering Heat (Immersing for 10 sec. at 260 °C)

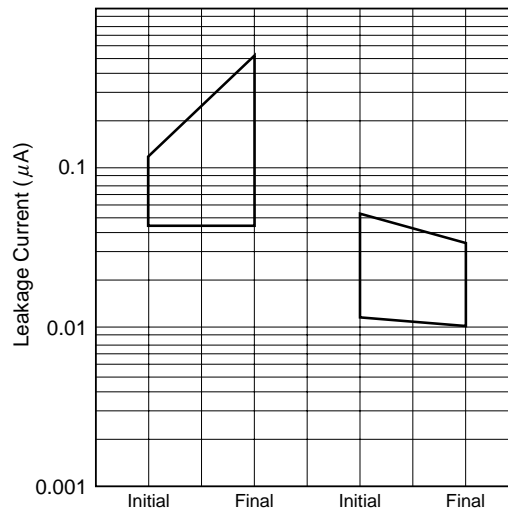
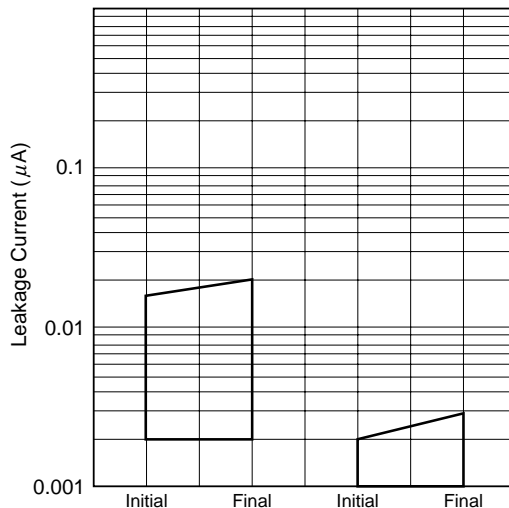
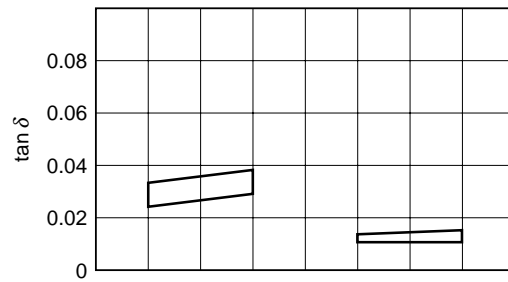
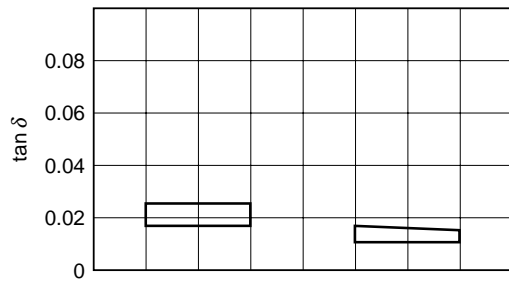
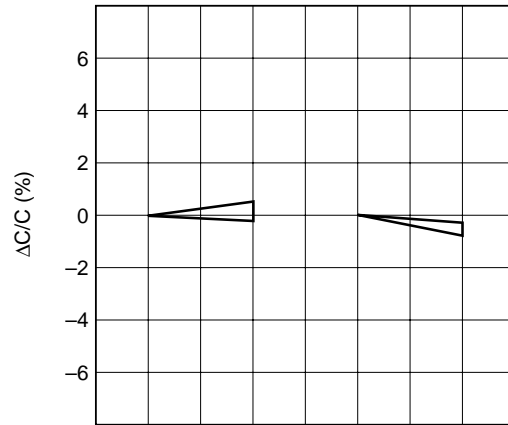
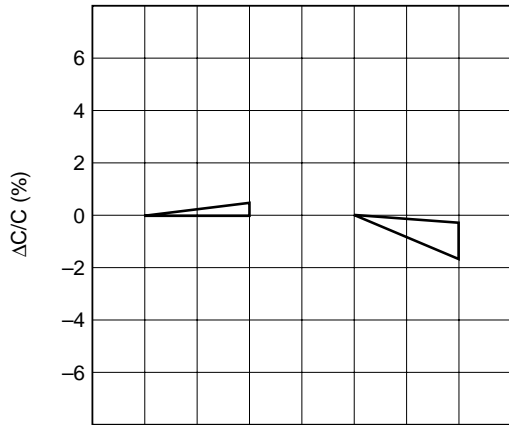

3.3 μ F/4 V A Case 0.33 μ F/35 V A Case

68 μ F/4 V D Case 6.8 μ F/35 V D Case

- R Series (Standard)

Damp Heat, Steady State (40°C, 90 to 95%RH)

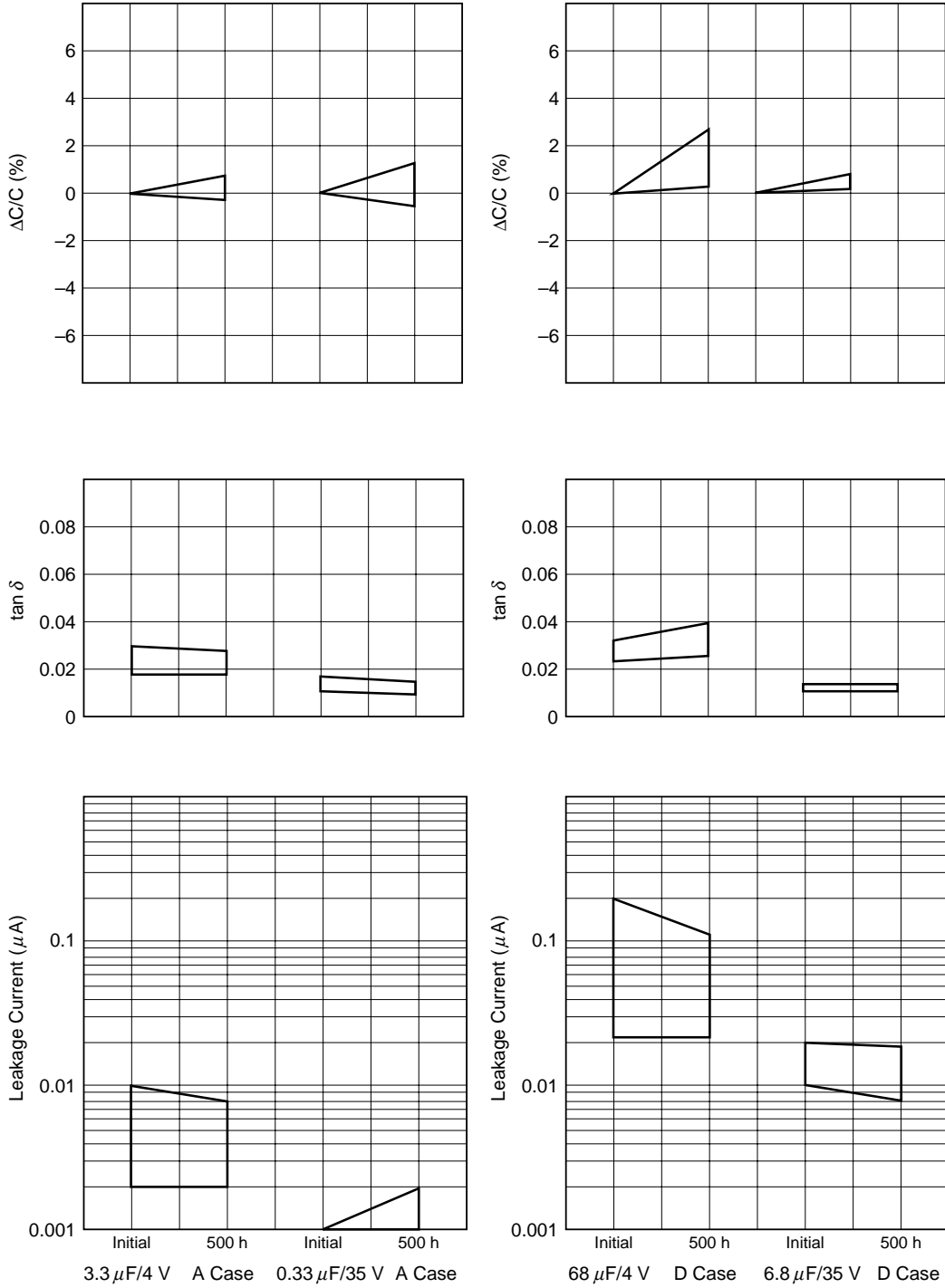

- R Series (Standard)

Endurance (85°C, Rated Voltage Applied)

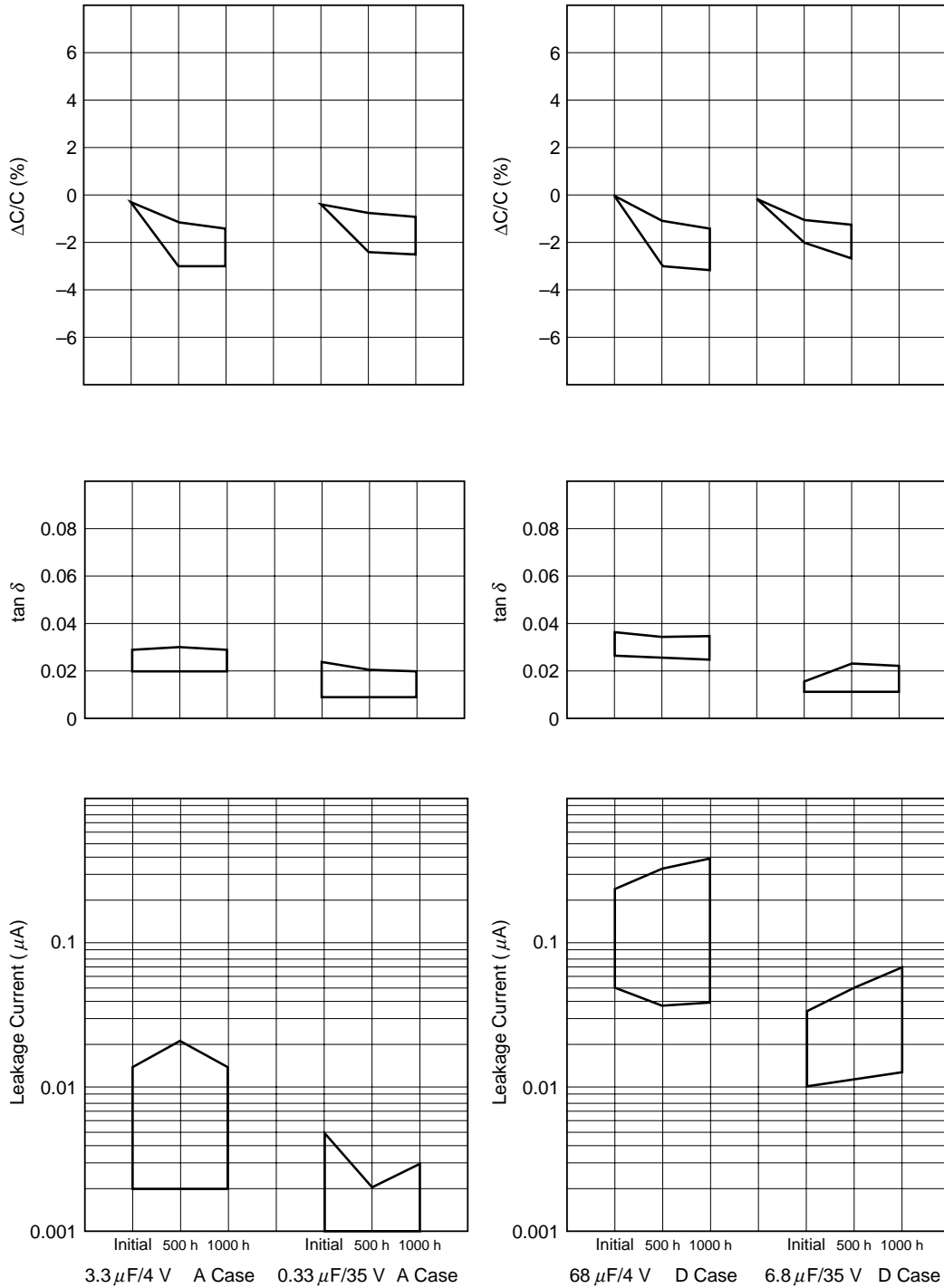

- R Series (Extended)

Characteristics at High and Low Temperature

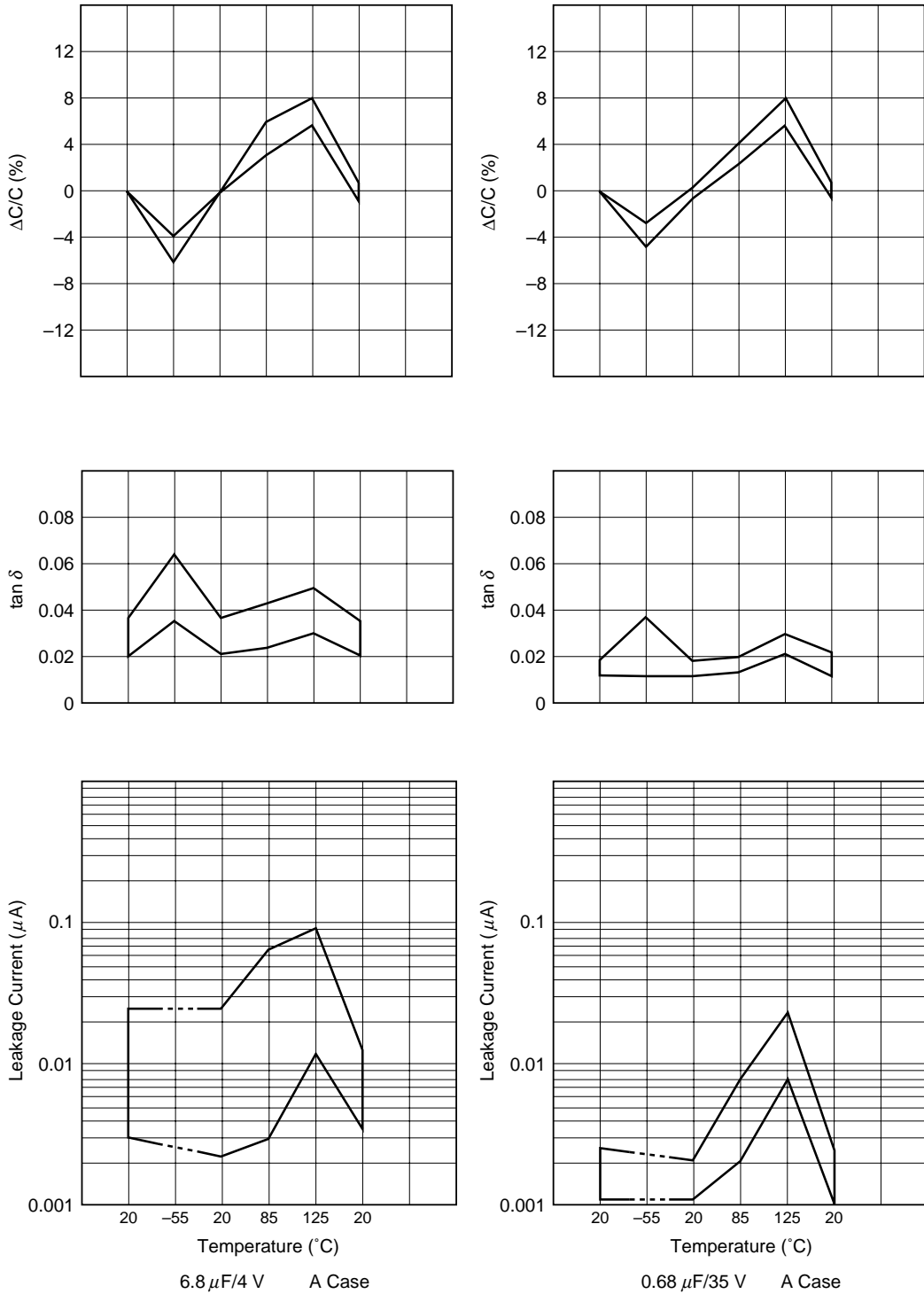

- R Series (Extended)

Characteristics at High and Low Temperature

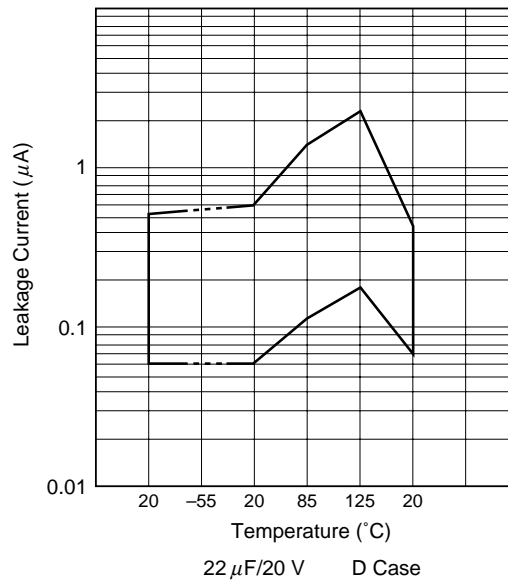
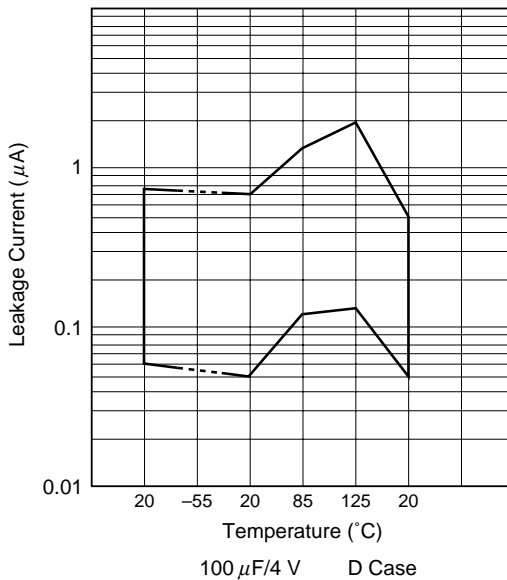
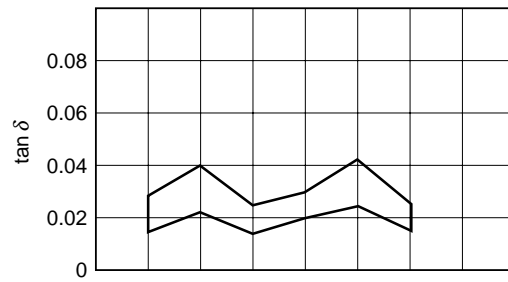
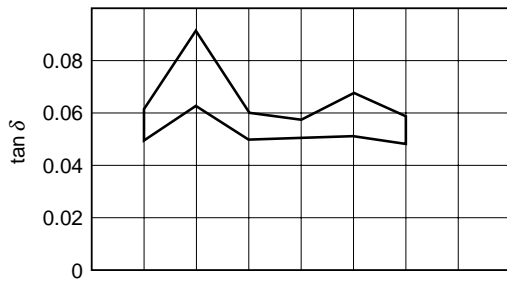
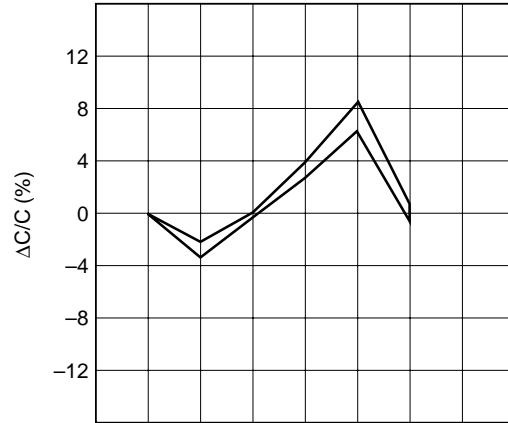
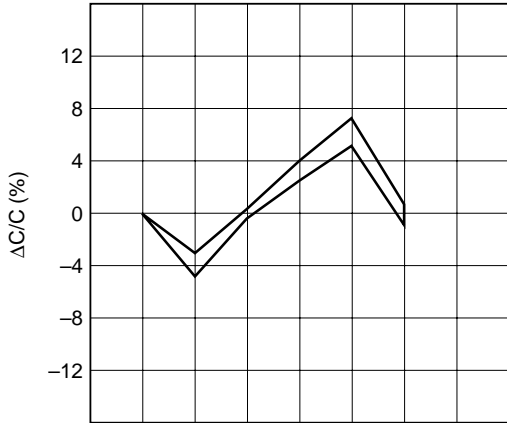

- R Series (Extended)

Resistance to Soldering Heat (Immersing for 10 sec. at 260°C)

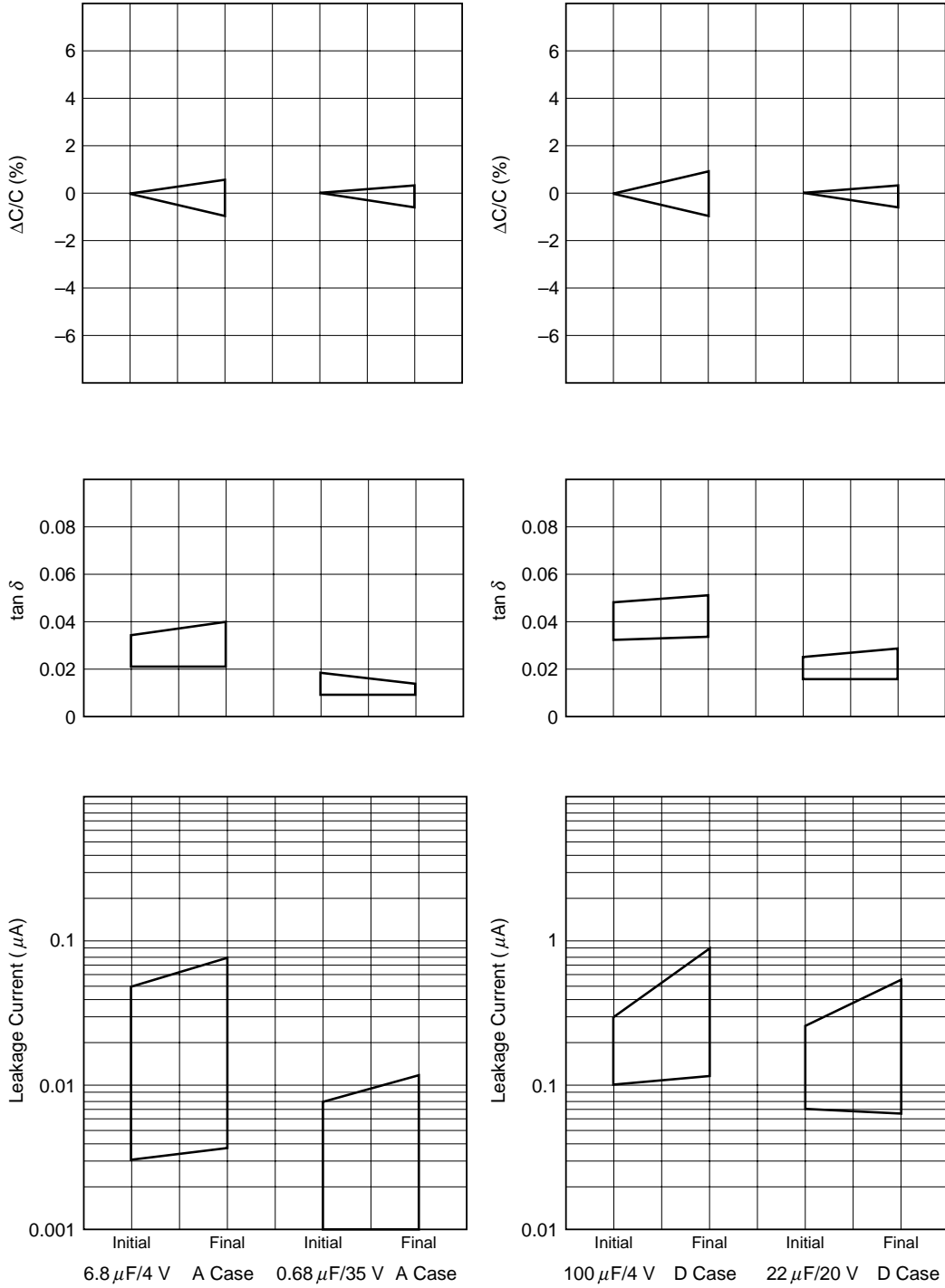

- R Series (Extended)

Damp Heat, Steady State (40°C, 90 to 95% RH)

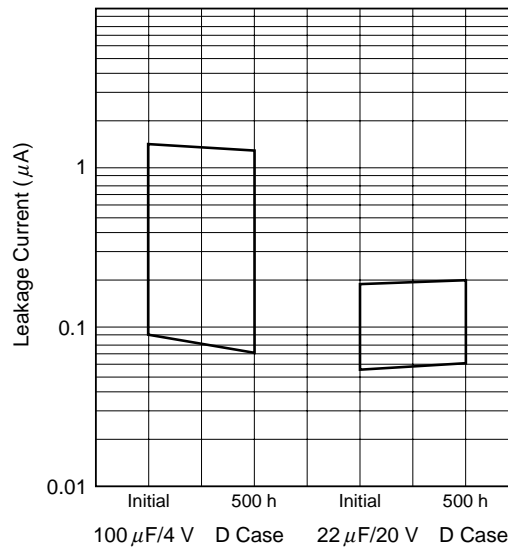
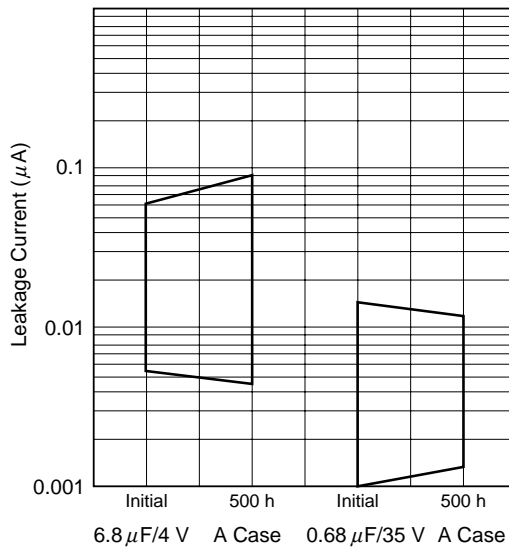
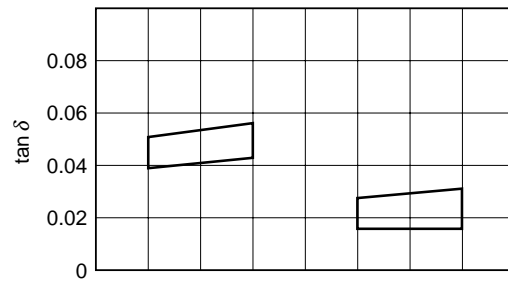
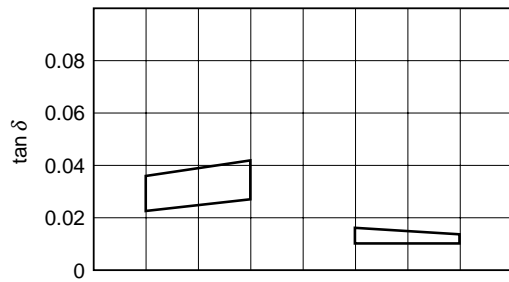
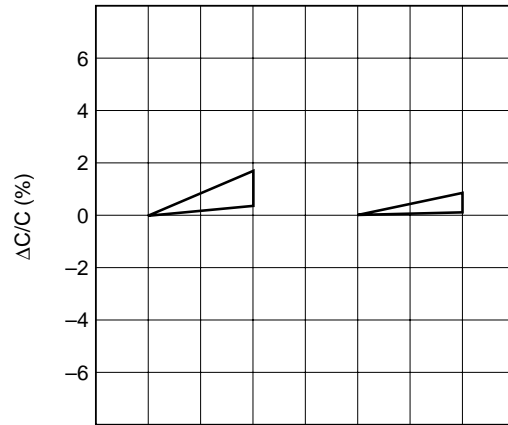
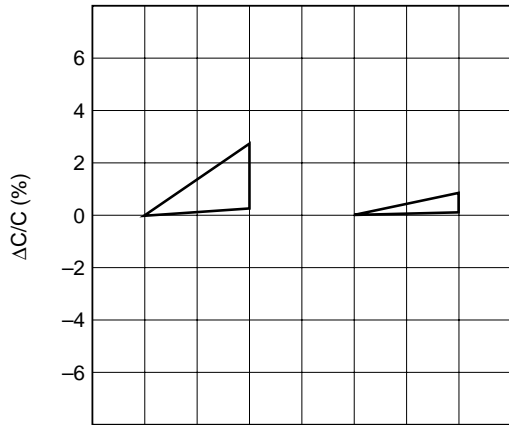

- R Series (Extended)

Endurance (85°C, Rated Voltage Applied)

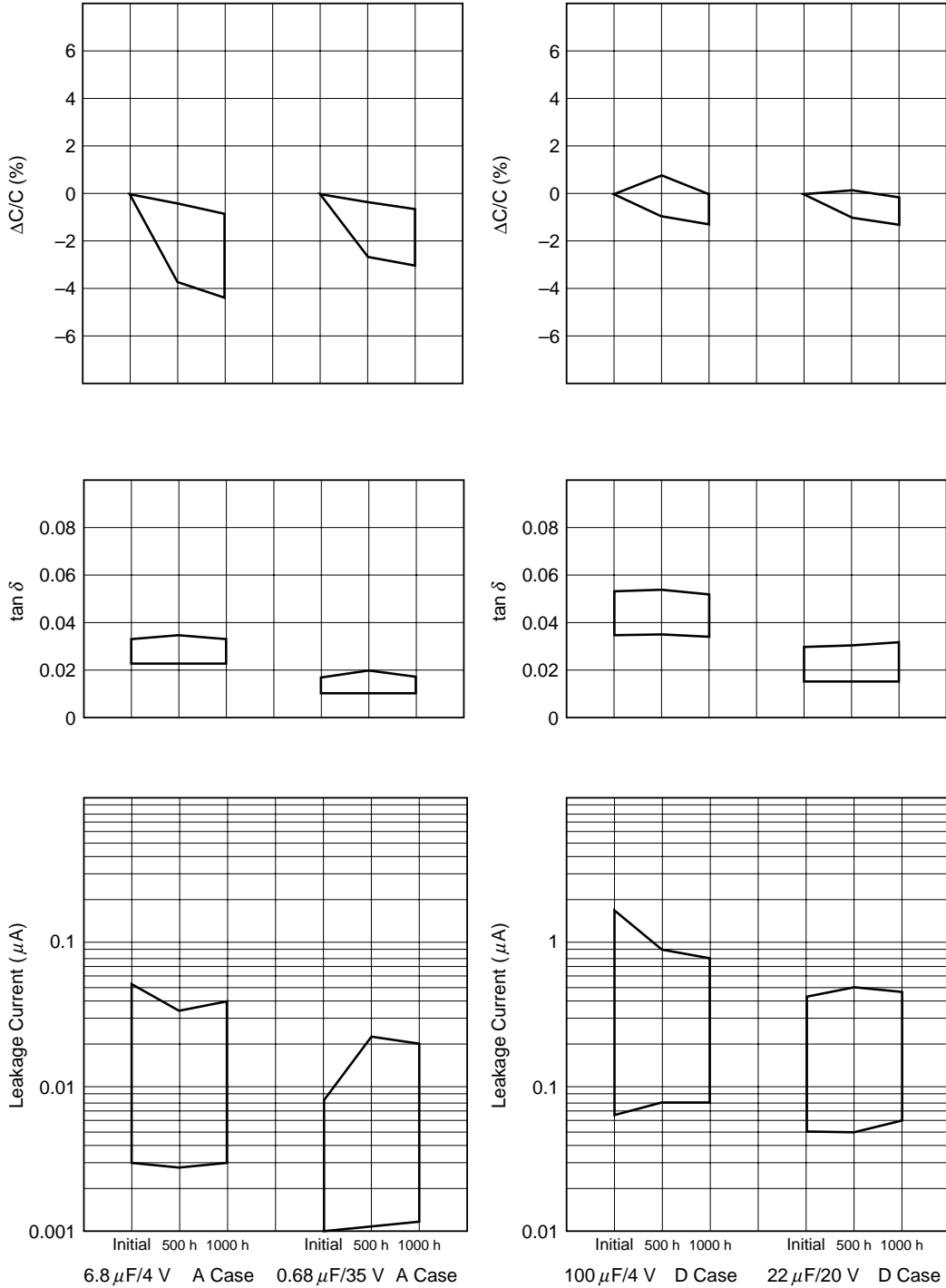

R Series (Standard)

Impedance – Frequency Characteristics

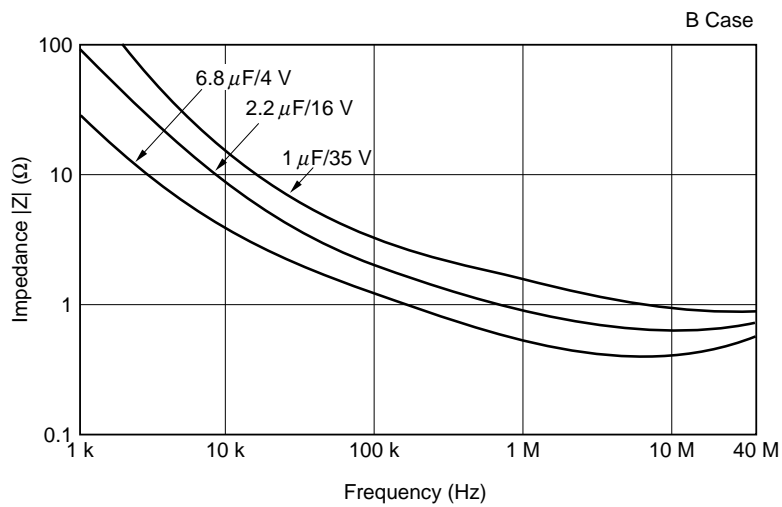
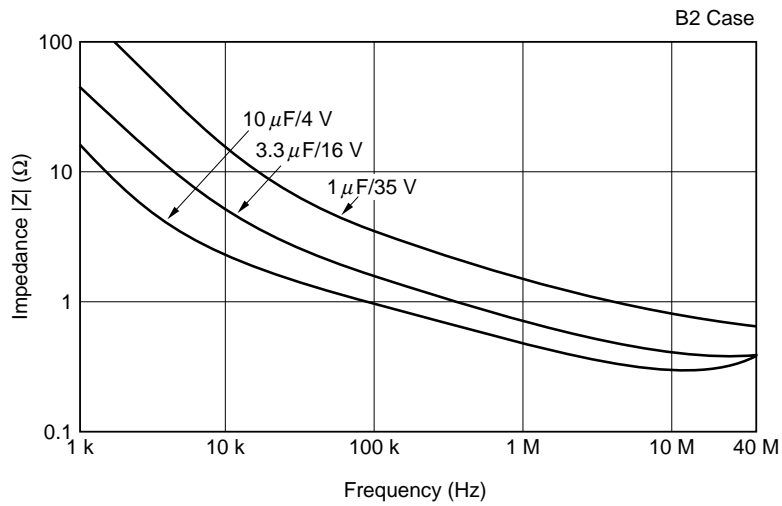
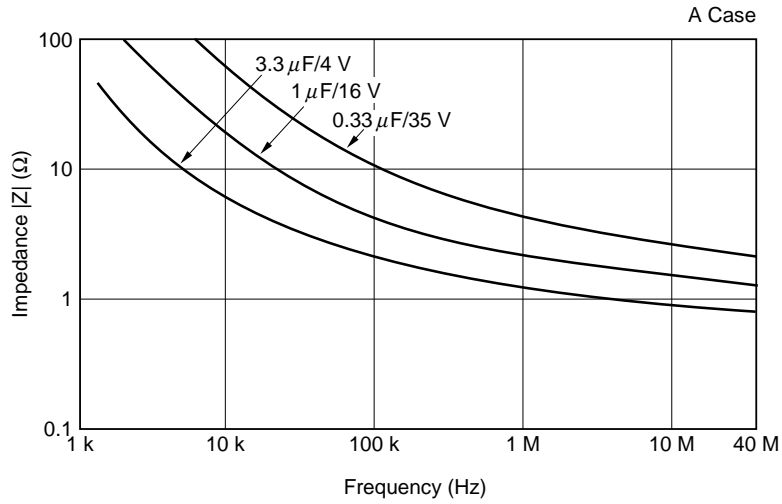

R Series (Standard)

Impedance – Frequency Characteristics

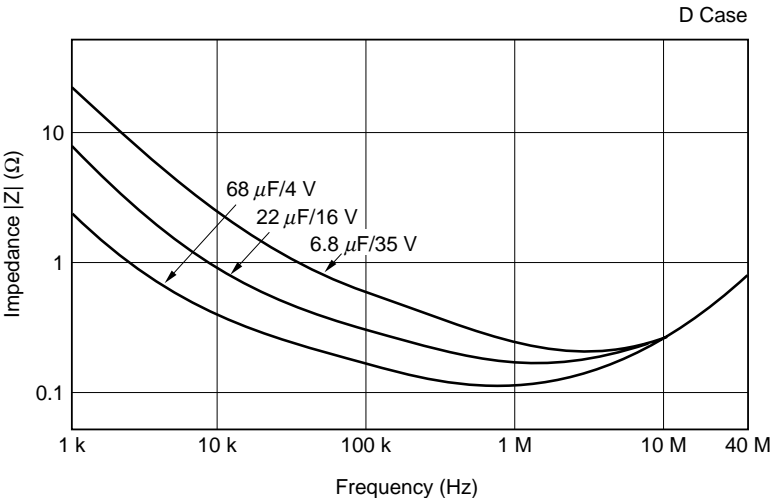
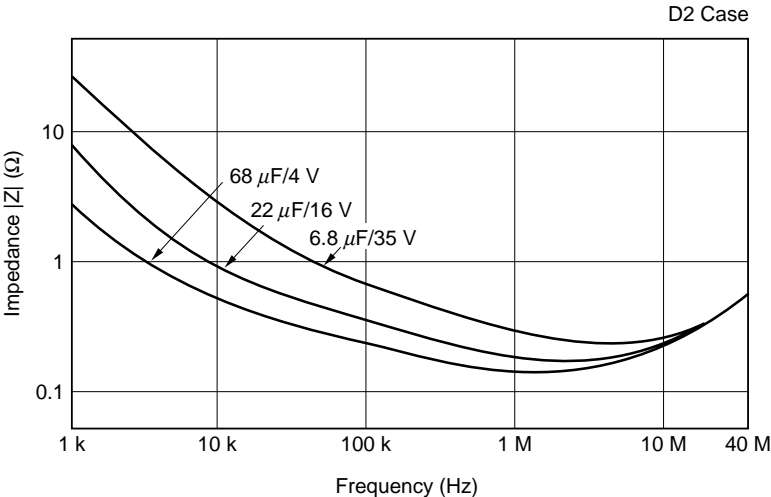
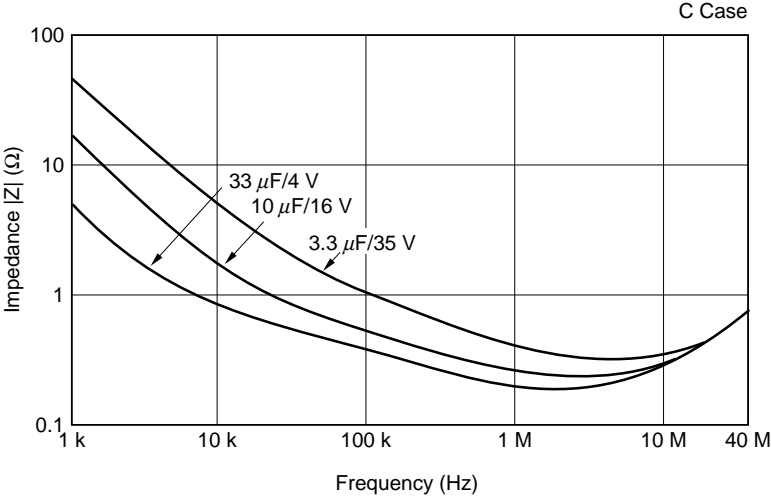

R Series (Extended)

Impedance – Frequency Characteristics

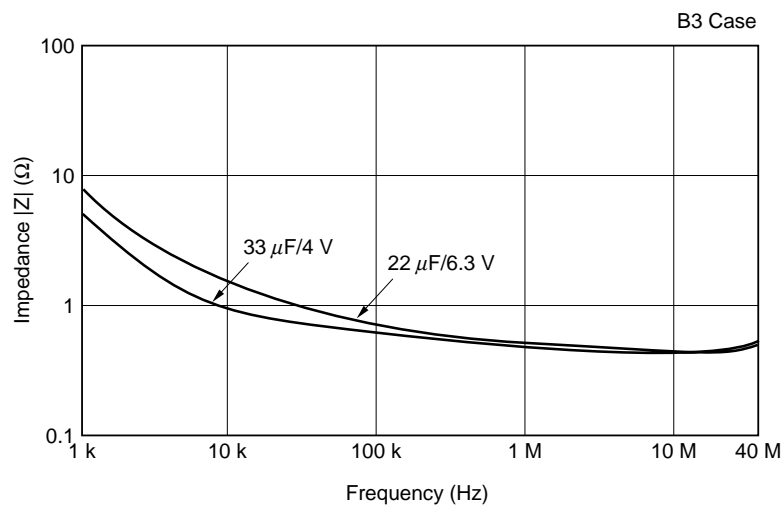
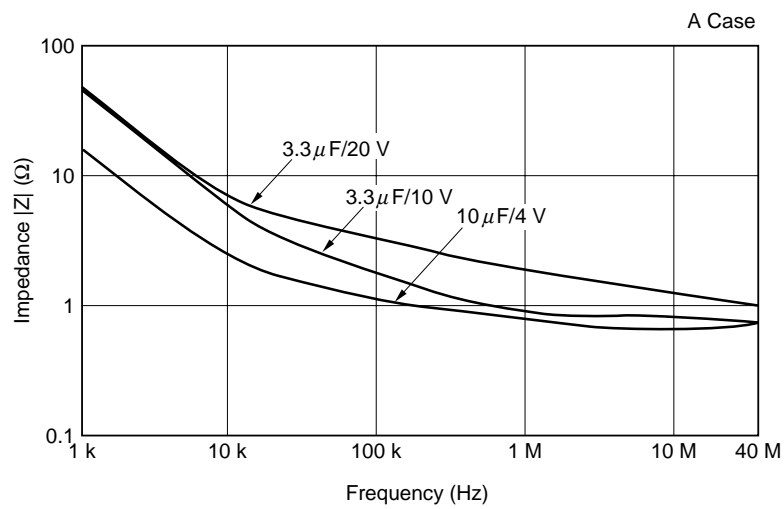
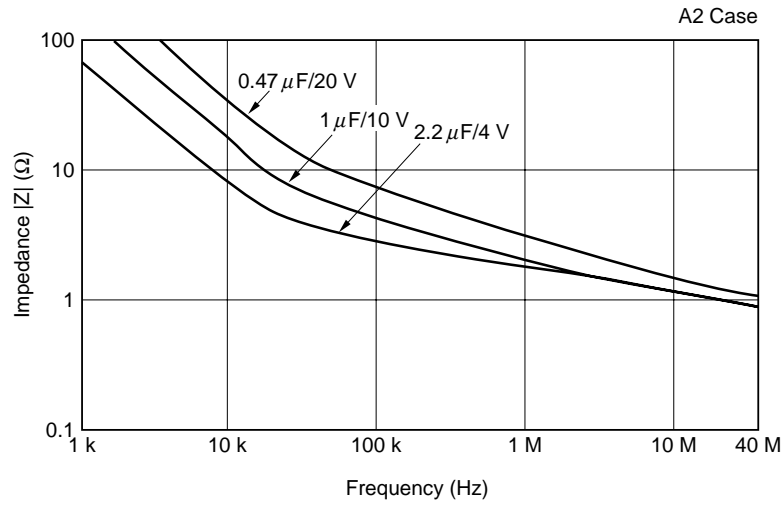

R Series (Extended)

Impedance – Frequency Characteristics

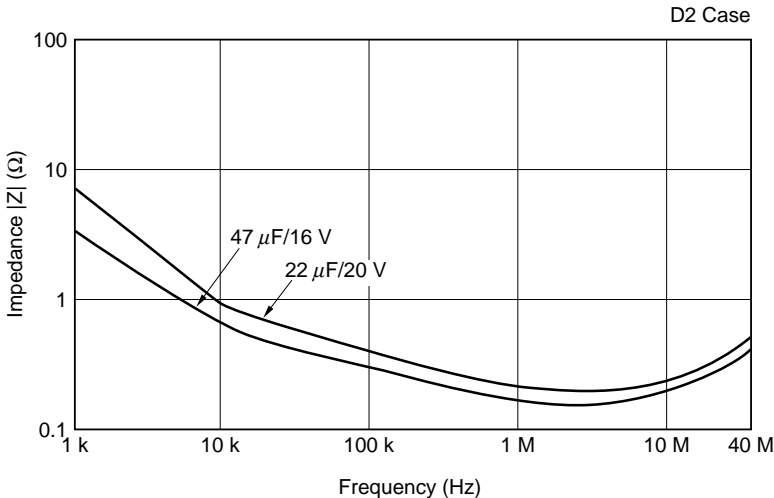
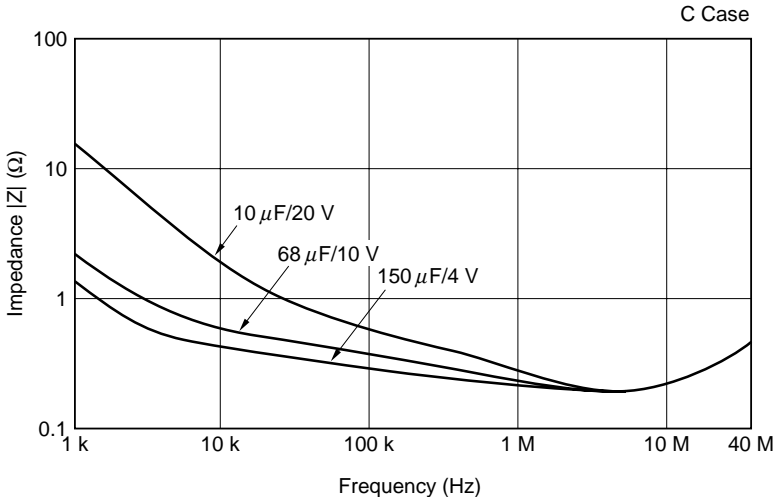
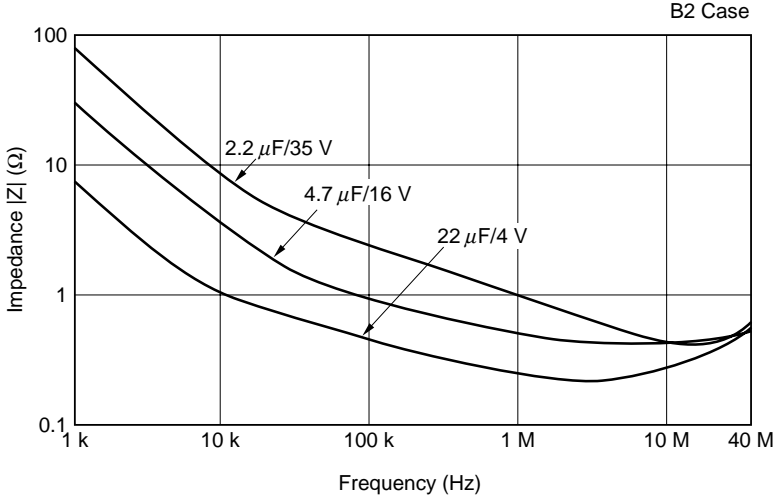

R Series (Extended)

Impedance – Frequency Characteristics

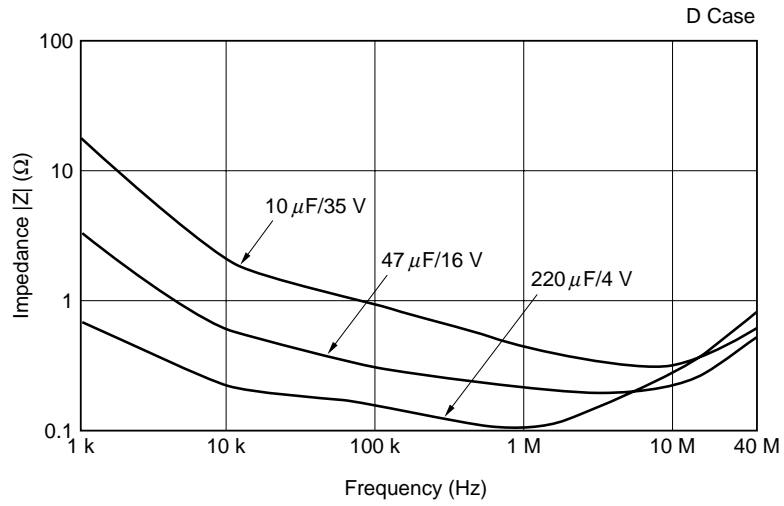

• TAPE AND REEL SPECIFICATIONS

Carrier Tape

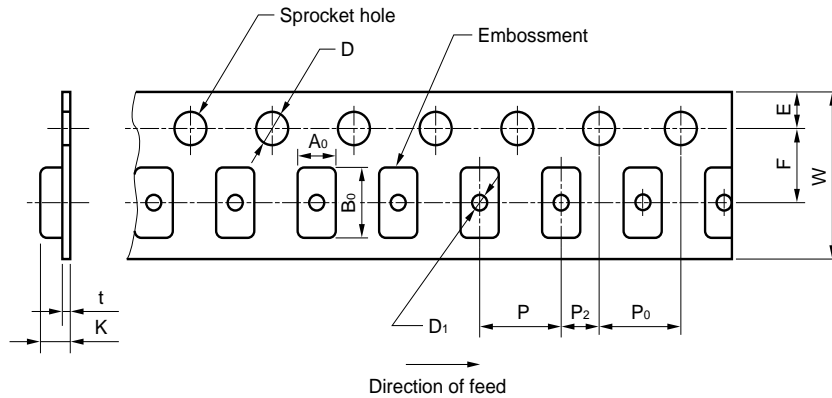

Case Code	EIA Code	$W \pm 0.3$ (± 0.012)	$F \pm 0.05$ (± 0.002)	$E \pm 0.1$ (± 0.004)	$P \pm 0.1$ (± 0.004)	$P_2 \pm 0.05$ (± 0.002)	$P_0 \pm 0.1$ (± 0.004)	$D_0^{+0.1}_0$ ($+0.004_0$)	D_1 Min. (*)	t	$A_0 \pm 0.2$ (± 0.008)	$B_0 \pm 0.2$ (± 0.008)	$K \pm 0.2$ (± 0.008)
P	2012	8 (0.315)	3.5 (0.138)	1.75 (0.069)	4 (0.157)	2 (0.079)	4 (0.157)	$\phi 1.5$ (0.059)	$\phi 1.0$ (0.039)	0.2 (0.008)	1.4 (0.055)	2.2 (0.087)	1.4 (0.055)
A2	3216L										1.9 (0.075)	3.5 (0.138)	
A	3216										3.2 (0.126)	3.8 (0.150)	1.9 (0.075)
B3	3528L										3.3 (0.130)	3.8 (0.150)	1.4 (0.055)
B2	3528	12 (0.472)	5.5 (0.217)	1.75 (0.069)	8 (0.315)	2 (0.079)	4 (0.157)	$\phi 1.5$ (0.059)	$\phi 1.5$ (0.059)	0.3 (0.012)	3.1 (0.122)	5.1 (0.201)	2.6 (0.102)
B	-										3.7 (0.146)	6.4 (0.252)	3.0 (0.118)
C	6032										5.1 (0.201)	6.2 (0.244)	3.6 (0.142)
D2	-										0.4 (0.016)	5.1 (0.201)	6.2 (0.244)
D	7343	12 (0.472)	5.5 (0.217)	1.75 (0.069)	8 (0.315)	2 (0.079)	4 (0.157)	$\phi 1.5$ (0.059)	$\phi 1.5$ (0.059)	0.3 (0.012)	4.8 (0.189)	7.7 (0.303)	3.3 (0.130)

(*): $\phi 330$ only

Leader and Trailer

Unit: mm (inch)

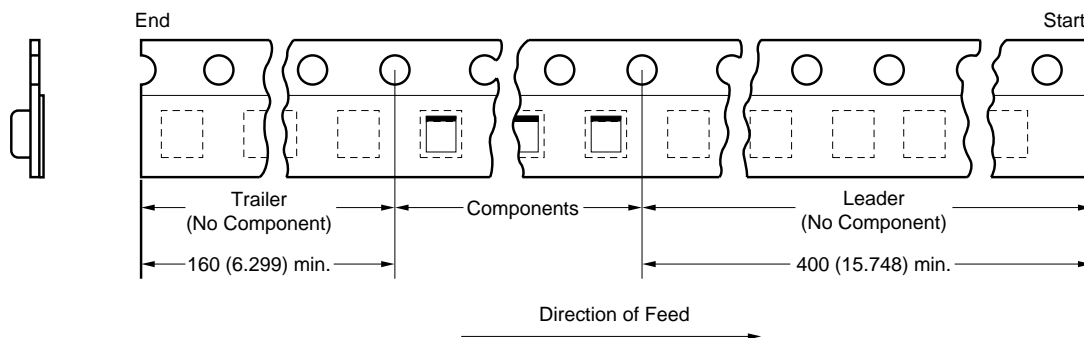

Reel

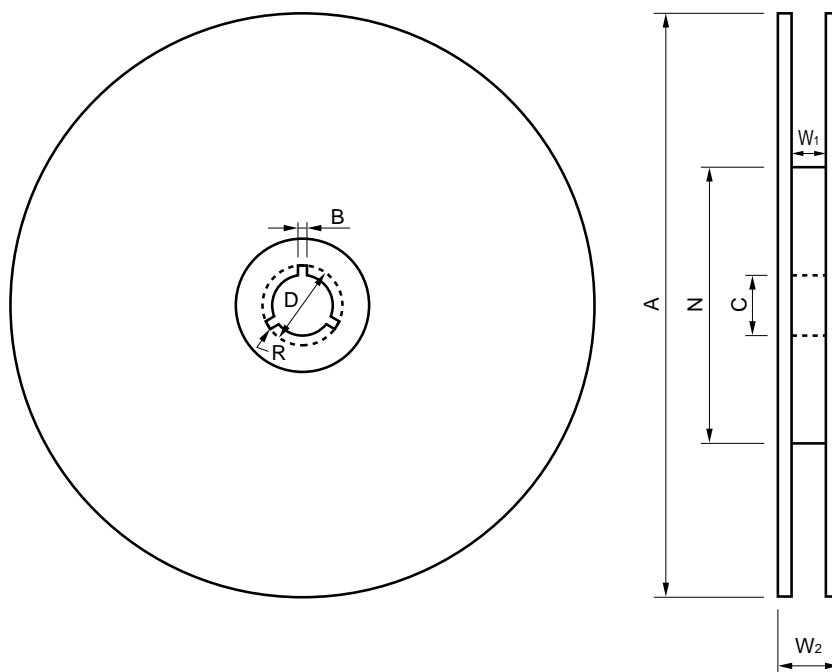

Unit: mm (inch)

Tape Width	A±0.2 (±0.079)	N Min.	C±0.5 (±0.020)	D±0.5 (±0.020)	B±0.5 (±0.020)	W ₁	W ₂ Max.	R
8 (0.315)	φ178 (7)	φ20 (1.969)	φ13 (0.512)	φ21 (0.827)	2 (0.079)	10±1.0 (0.394±0.039)	14.5 (0.571)	1 (0.039)
12 (0.472)						14.5±1.0 (0.571±0.039)	18.5 (0.728)	
8 (0.315)	φ330 (13)	φ80 (3.150)	φ13 (0.512)	φ21 (0.827)	2 (0.079)	9.5±0.5 (0.374±0.020)	14.5 (0.571)	1 (0.039)
12 (0.472)						13.5±0.50 (0.531±0.020)	18.5 (0.728)	

[QUANTITY PER REEL]

Case Size	φ178	φ330
P	3,000	-
A2	3,000	10,000
A	2,000	9,000
B3	3,000	10,000
B2	2,000	5,000
B	1,500	5,000
C, D2, D	500	2,500

Notes on Correct Use

1. Circuit Design

(1) Expecting Reliability

The reliability of the solid tantalum capacitor is heavily influenced by environmental conditions such as temperature, humidity, shock, vibration, mechanical stresses, and electric stresses including applied voltage, current, ripple current, transient current and voltage, and frequency. When using solid tantalum capacitors, therefore, provide enough margin to these conditions, so that the reliability of the capacitors is maintained.

Voltage and temperature are important parameters when estimating the reliability (field failure rate).

The field failure rate of a solid tantalum capacitor can be calculated by the following expression if emphasis is placed only on the voltage and temperature:

$$\lambda = \lambda_0 (V/V_0)^3 \times 2^{(T-T_0)/10}$$

where,

λ : estimated failure rate in actual working condition temperature:
T, voltage: V

λ_0 : failure rate under rated load (See table below.)
temperature: T₀, voltage: V₀

Failure Rate

Series	Failure Rate
R (standard)	1%/1000 h
R (extended)	1%/1000 h
SVS	1%/1000 h
SVH	0.5%/1000 h
SVF	1%/1000 h
SVZ	1%/1000 h

<Test Conditions>

Temperature: 85°C
Voltage: Rated Voltage
Rs: 3 Ω

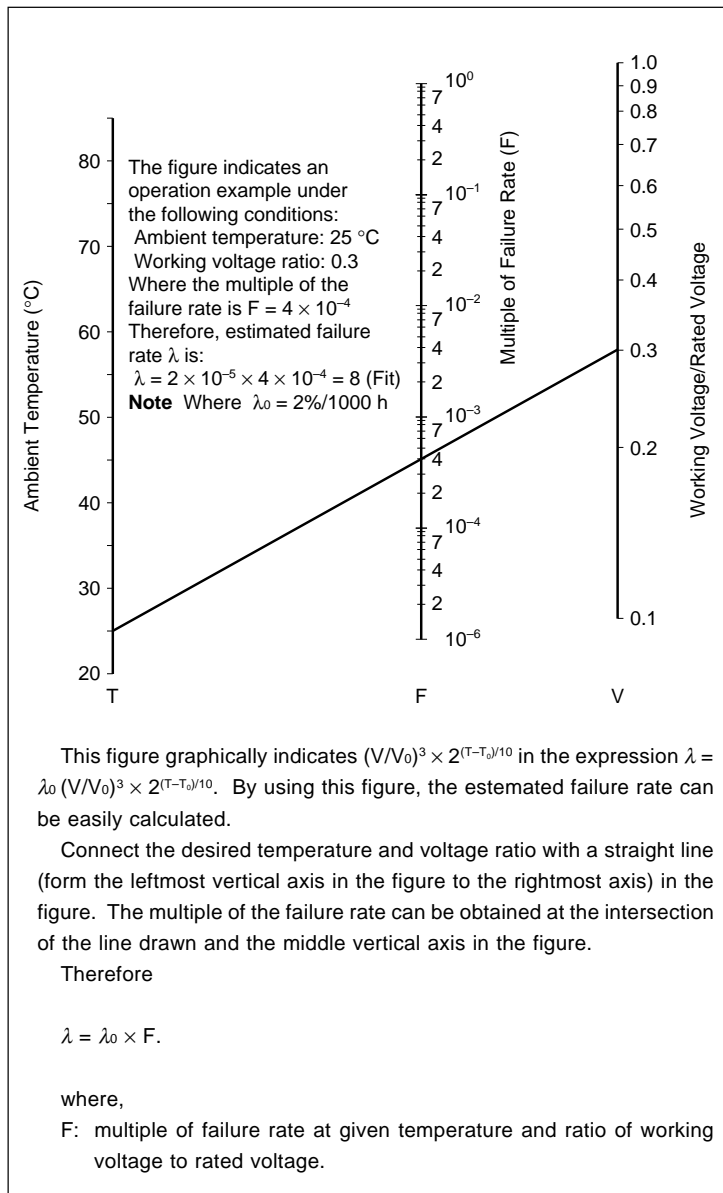

2. Ripple Voltage

- (1) Keep the sum of the DC voltage and peak value of the ripple voltage to within the rated voltage.
- (2) If a ripple voltage is applied to the capacitor, the peak value of the ripple voltage must be kept to within the values shown in the following figures:

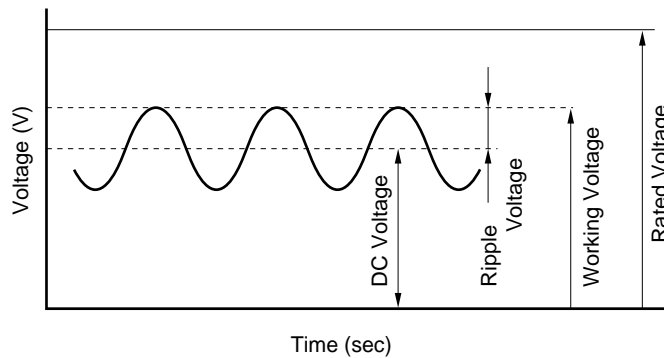
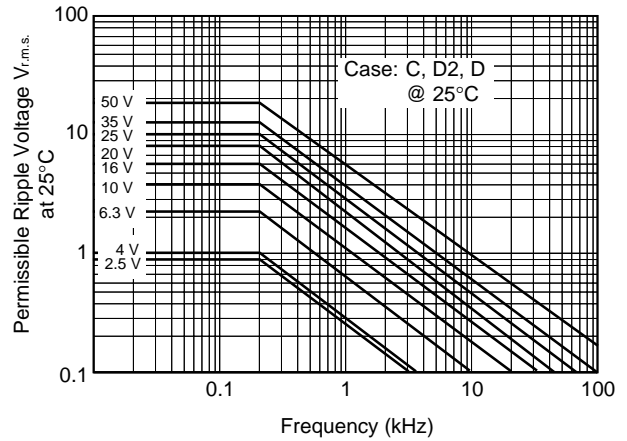
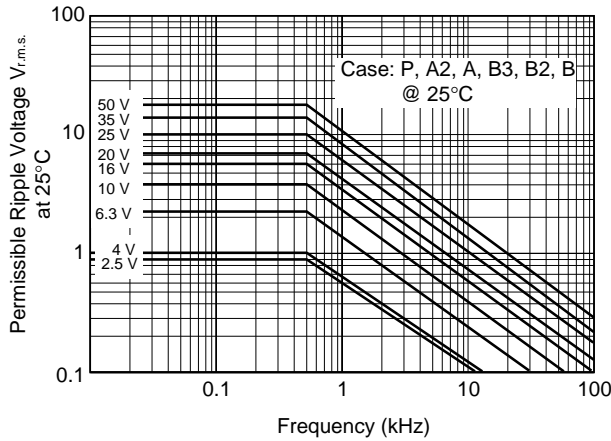

Calculate the permissible ripple voltage at a temperature higher than that specified in these figure by using the following expression;

$$V_{r.m.s} \text{ (at } 50^{\circ}\text{C)} = 0.7 \times V_{r.m.s} \text{ (at } 25^{\circ}\text{C)}$$

$$V_{r.m.s} \text{ (at } 85^{\circ}\text{C)} = 0.5 \times V_{r.m.s} \text{ (at } 25^{\circ}\text{C)}$$

$$V_{r.m.s} \text{ (at } 125^{\circ}\text{C)} = 0.3 \times V_{r.m.s} \text{ (at } 25^{\circ}\text{C)}$$

- (3) Keep the negative peak value of the ripple voltage to within the permissible reverse voltage value specified in the following paragraph 3.

3. Reverse voltage

- (1) Do not apply a reverse voltage to the solid tantalum capacitor because the capacitor is of polar type. If reverse voltage cannot be avoided, it must be applied for a short time and must not exceed the following value:
 25 °C 10% max. of rated voltage or 3 Vdc, which is smaller
 85 °C 5% max. of rated voltage
 125 °C 1% max. of rated voltage

- (2) The figure on the right shows the relations between current and reverse voltage.

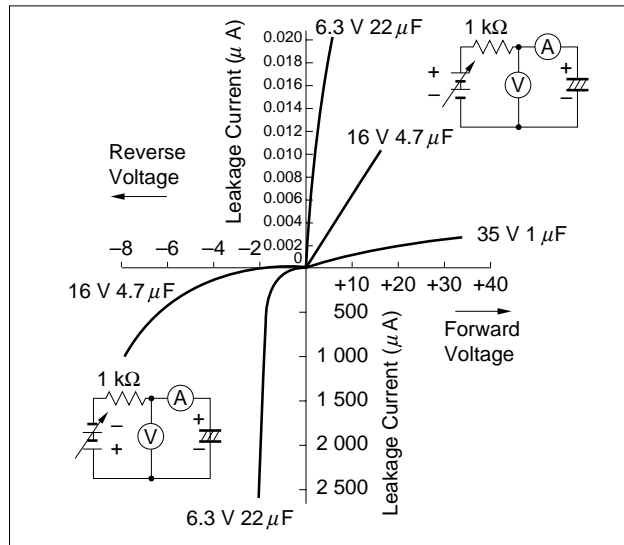

4. Applied Voltage

- (1) For general applications, apply 70% or less of the rated voltage to the capacitor.
- (2) When the capacitor is used in a power line or a low-impedance circuit, keep the applied voltage to within 30% (50% max.) of the rated voltage to avoid adverse influence of inrush current.
- (3) Derated voltage at 85°C or more.
 When using the capacitor at a temperature of 85°C or higher, calculate reduced voltage U_T from the following expression. Note, however, that the ambient temperature must not exceed 125°C.

The rated voltage ratio is as shown in the figure on the right.

$$U_T = U_R - \frac{U_R - U_C}{40} (T - 85)$$

Where,

U_R : rated voltage (V)

U_C : derated voltage at 125°C

T : ambient temperature (°C)

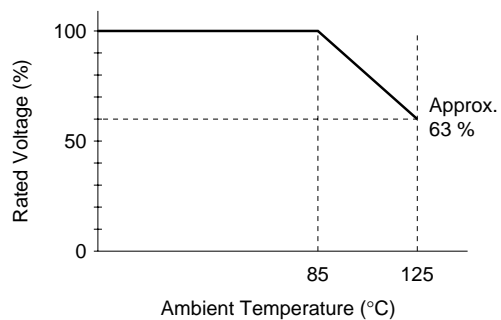

5. Current (Series Resistance)

As shown in the figure on the right, reliability is increased by inserting a series resistance of at least 3 Ω/V into circuits where current flow is momentary (switching circuits, charge/discharge circuits, etc). If the capacitor is in a low-impedance circuit, the voltage applied to the capacitor should be less than 1/2 to 1/3 of the DC rated voltage.

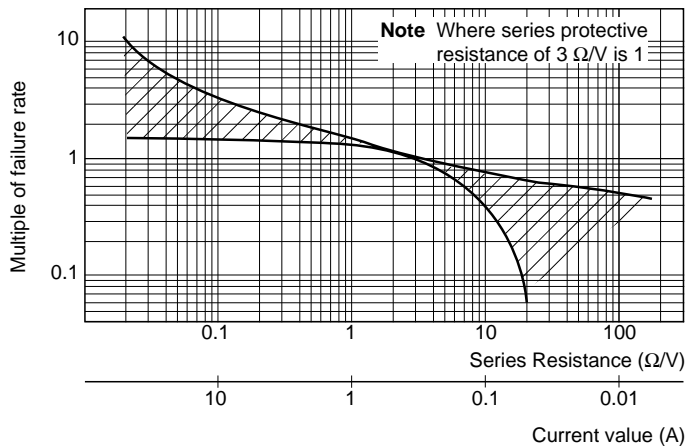

6. Mounting

(1) Direct Soldering

Keep in mind the following points when soldering the capacitor by means of jet soldering or dip soldering:

(a) Temporarily fixing resin

Because the chip tantalum capacitors are larger in size and subject to more force than the chip multilayer ceramic capacitors or chip resistors, more resin is required to temporarily secure the solid tantalum capacitors. However, if too much resin is used, the resin adhered to the patterns on a printed circuit board may adversely affect the solderability.

(b) Pad Pattern Design

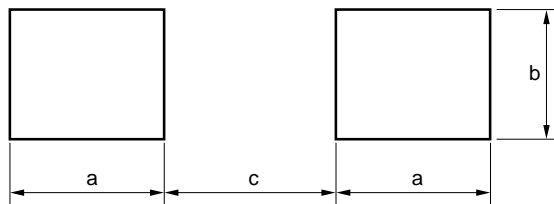

Case Size	a	b	c
P	2.2	1.4	0.7
A2, A	2.9	1.7	1.2
B3, B2	3.0	2.8	1.6
B	3.3	1.9	2.4
C	4.1	2.3	2.4
D2	5.4	2.9	2.4
D	5.2	2.9	3.7

The above dimensions are for reference only. If the capacitor is to be mounted by this method, and if the pattern is too small, the solderability may be degraded.

(c) Temperature and Time

Keep the peak temperature and time to within the following values:

Solder temperature 260°C max.

Time 5 seconds max. (10 seconds max. for SVH)

Whenever possible, perform preheating (at 150°C max.) for smooth temperature profile. To maintain the reliability, mount the capacitor at a low temperature and in a short time whenever possible.

(d) Component Layout

If many types of chip components are mounted on a printed circuit board which is to be soldered by means of jet soldering, solderability may not be uniform over the entire board depending on the layout and density of the components on the board (also take into consideration generation of flux gas).

(e) Flux

Use resin-based flux. Do not use flux with strong acidity.

(2) Reflow Soldering

Keep in mind the following points when soldering the capacitor in a soldering oven or with a hot plate:

(a) Pad Pattern Design

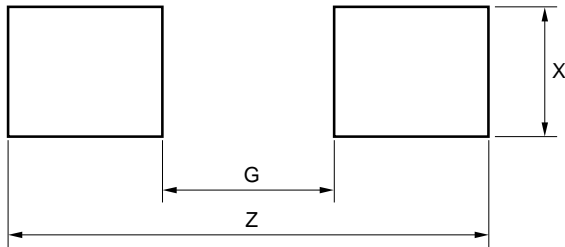

Case Size	G max.	Z min.	X min.
P	0.5	2.6	1.2
A2, A	1.1	3.8	1.5
B3, B2	1.4	4.1	2.7
B	2.6	5.9	2.9
C	2.9	6.9	2.7
D2	2.7	6.7	2.9
D	4.1	8.2	2.9

The above dimensions are for reference only. Note that if the pattern is too big, the component may not be mounted in place.

(b) Temperature and Time

Keep the peak temperature and time to within the following values:

Solder temperature ... 260°C max.

Time: 10 seconds max.

Whenever possible, perform preheating (at 150°C max.) for smooth temperature profile. To maintain the reliability, mount the capacitor at a low temperature and in a short time whenever possible. The peak temperature and time shown above are applicable when the capacitor is to be soldered in a soldering oven or with a hot plate. When the capacitor is soldered by means of infrared reflow soldering, the internal temperature of the capacitor may rise beyond the surface temperature.

(3) Using Soldering Iron

When soldering the capacitor with a soldering iron, controlling the temperature at the tip of the soldering iron is very difficult. However, it is recommended that the following temperature and time be observed to maintain the reliability of the capacitor:

Iron Temperature 300°C max.

Time 3 seconds max.

Iron Power 30 W max.