

LM2685

LM2685 Dual Output Regulated Switched Capacitor Voltage Converter



Literature Number: SNVS055B

Dual Output Regulated Switched Capacitor Voltage Converter

General Description

The LM2685 CMOS charge-pump voltage converter operates as an input voltage doubler, +5V regulator and inverter for an input voltage in the range of +2.85V to +6.5V. Five low cost capacitors are used in this circuit to provide up to 50mA of output current at +5V ($\pm 5\%$), and 15mA at -5V. The LM2685 operates at a 130 kHz switching frequency to reduce output resistance and voltage ripple. With an operating current of only 800 μ A (operating efficiency greater than 80% with most loads) and 6 μ A typical shutdown current, the LM2685 is ideal for use in battery powered systems. The device is in a small 14-pin TSSOP package.

Features

- +5V regulated output
- Inverts $V_{O5}(+5V)$ to $V_{NEG}(-5V)$
- Doubles input supply voltage
- TSSOP-14 package
- 80% typical conversion efficiency at 25mA
- Input voltage range of 2.85V to 6.5V
- Independent shutdown control pins

Applications

- Cellular phones
- Pagers
- PDAs
- Handheld instrumentation
- 3.3V to 5V voltage conversion applications

Typical Application and Connection Diagram

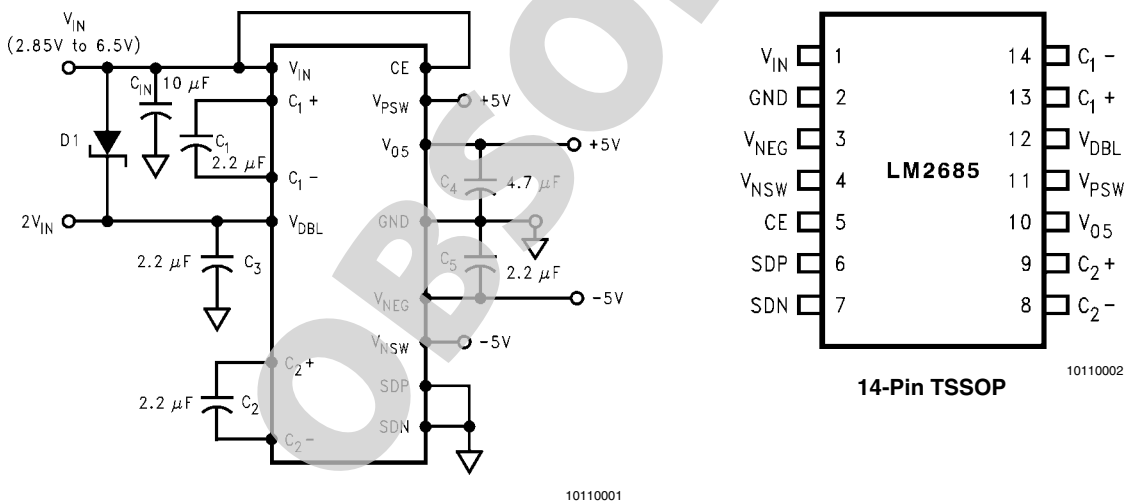

Ordering Information

Order Number	Package Type	NSC Package Drawing	Supplied As
LM2685MTC	TSSOP-14	MTC14	94 Units, Rail
LM2685MTCX	TSSOP-14	MTC14	2.5k Units, Tape and Reel

Pin Descriptions

Pin No.	Name	Function
1	V_{IN}	Power supply input voltage.
2	GND	Power supply ground.
3	V_{NEG}	Negative output voltage created by inverting V_{05} .
4	V_{NSW}	V_{NEG} output connected through a series switch, NSW.
5	CE	Chip enable input. This pin is high for normal operation and low for shutdown. (See Shutdown and Load Disconnect section in the Detailed Device Description division).
6	SDP	Positive side shutdown input. This pin is low for normal operation and high for positive side shutdown and V_{PSW} load disconnect. (See Shutdown and Load Disconnect section in the Detailed Device Description division).
7	SDN	Negative side shutdown input. This pin is low for normal operation and high for negative side shutdown and V_{NSW} load disconnect. (See Shutdown and Load Disconnect section in the Detailed Device Description division).
8	C_2^-	The negative terminal of inverting charge-pump capacitor, C2.
9	C_2^+	The positive terminal of inverting charge-pump capacitor, C2.
10	V_{05}	Regulated +5V output.
11	V_{PSW}	V_{05} output connected through a series switch, PSW.
12	V_{DBL}	Voltage Doubler Output. ($2.85V \leq V_{IN} \leq 5.4V$. See Voltage Doubler section).
13	C_1^+	The positive terminal of doubling charge-pump capacitor, C1.
14	C_1^-	The negative terminal of doubling charge-pump capacitor, C1.

Absolute Maximum Ratings (Note 1)

If Military/Aerospace specified devices are required, please contact the National Semiconductor Sales Office/Distributors for availability and specifications.

Supply Voltage (V_{IN} to GND or GND to V_{NEG})	6.8V
SDN, SDP, CE	(GND – 0.3V) to ($V_{IN} + 0.3V$)
V_{05} Continuous Output Current	80mA
V_{05} Short-Circuit Duration to GND (Note 2)	Indefinite

Continuous Power Dissipation ($T_A = 25^\circ\text{C}$) (Note 3)	600mW
T_{JMAX} (Note 3)	150°C
θ_{JA} (Note 3)	140°C/W
Operating Ambient Temp. Range	–40°C to 85°C
Operating Junction Temp. Range	–40°C to 125°C
Storage Temp. Range	–65°C to 150°C
Lead Temp. (Soldering, 10 sec.)	300°C
ESD Rating (Note 4)	2kV

Electrical Characteristics

Limits with standard typeface apply for $T_J = 25^\circ\text{C}$, and limits in **boldface type** apply over the full temperature range. Unless otherwise specified $V_{IN} = 3.6V$, $C_1 = C_2 = C_3 = C_5 = 2.2\mu\text{F}$, $C_4 = 4.7\mu\text{F}$ (Note 5)

Symbol	Parameter	Conditions	Min	Typ	Max	Units
V^+	Supply Voltage		2.85		6.5	V
I_Q	Supply Current	No Load		800	1600	μA
		No Load, $V_{IN} = 6.5V$		300	600	
I_{SD}	Shutdown Supply Current	$V_{IN} = 6.5V$		6	30	μA
V_{SD}	Shutdown Pin Input Voltage for CE, SDP, SDN	Logic Input High @ 6.5V	2.4			V
		Logic Input Low @ 6.5V			0.8	
$I_L (+5V)$	Output Current at V_{05}	$2.85V < V_{IN} < 6.5V$			50	mA
$R_O (-5V)$	Output Resistance at V_{NEG}	$I_L = 15\text{mA}$ (Note 6)		20	40	Ω
F_{SW}	Switch Frequency		85	130	180	kHz
P_{EFF}	Average Power Efficiency at V_{05}	$2.85V \leq V_{IN} \leq 6.5V$ $I_L = 25\text{mA}$ to GND		82		%
V_{05}	Output Regulation	$1\text{mA} < I_L < 50\text{mA}$, $V_{IN} = 6.5V$ (Note 7)	4.848	5.05	5.252	V
		$1\text{mA} < I_L < 50\text{mA}$, $V_{IN} = 6.5V$ (Note 7)	4.797	5.05	5.303	
G_{LINE}	Line Regulation	$2.85V < V_{IN} < 3.6V$		0.25		%/ V
		$3.6V < V_{IN} < 6.5V$		0.05		
G_{LOAD}	Load Regulation	$1\text{mA} < I_L < 50\text{mA}$, $V_{IN} = 6.5V$		0.3	1.0	%
R_{SW}	Series Switch Resistance V_{NEG} to V_{NSW} V_{05} to V_{PSW}	$V_{IN} > 2.85V$		1.5		Ω
					5.0	

Note 1: Absolute Maximum Ratings indicate limits beyond which damage to the device may occur. Operating Ratings indicate conditions for which the device is intended to be functional, but do not guarantee specific performance limits. For guaranteed specifications and test conditions, see the Electrical Characteristics.

Note 2: V_{05} may be shorted to GND without damage. However, shorting V_{NEG} to V_{05} may damage the device and must be avoided. Also, for temperature above 85°C , V_{05} must not be shorted to GND or device may be damaged.

Note 3: The maximum allowable power dissipation is calculated by using $P_{DMAX} = (T_{JMAX} - T_A)/\theta_{JA}$, where T_{JMAX} is the maximum junction temperature, T_A is the ambient temperature and θ_{JA} is the junction-to-ambient thermal resistance of the specified package.

Note 4: The human body model is a 100 pF capacitor discharged through a 1.5k Ω resistor into each pin.

Note 5: In the typical operating circuit, capacitors C_1 and C_2 are 2.2 μF , 0.3 Ω maximum ESR capacitors. Capacitors with higher ESR will increase output resistance, reduce output voltage and efficiency.

Note 6: Specified output resistance includes internal switch resistance and ESR of capacitors. See the Detailed Device Description section.

Note 7: The 50 mA maximum current assumes no current is drawn from V_{DBL} pin. See Voltage Doubler section in the Detailed Device Description.

Typical Performance Characteristics Unless otherwise specified, $T_A = 25^\circ\text{C}$, $V_{IN} = 3.6\text{V}$.

Supply Current vs Input Voltage

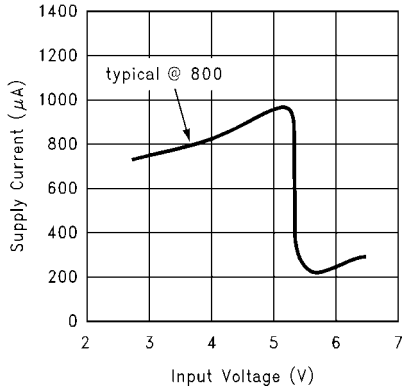

10110006

Supply Current vs Temperature

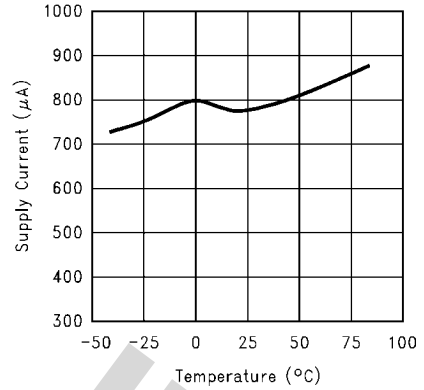

10110007

Efficiency vs Load Current

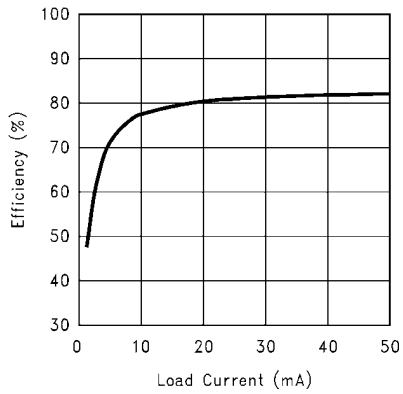

10110008

Output Voltage (V_{O5}) vs. Load Current

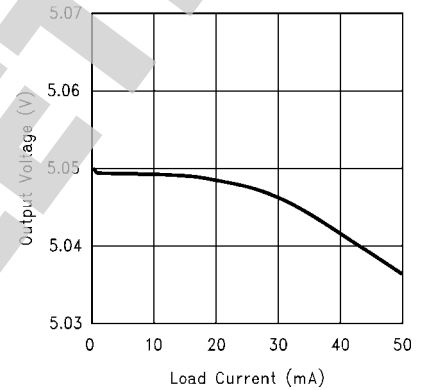

10110009

V_{O5} Voltage vs. Input Voltage

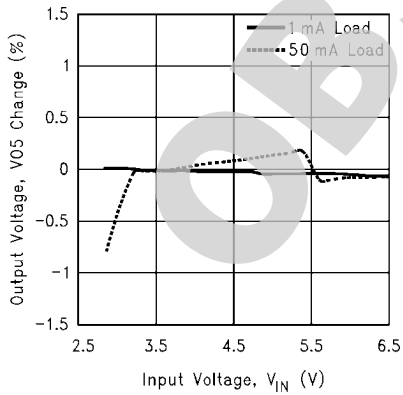

10110021

Output Resistance (V_{NEG}) vs. Temperature

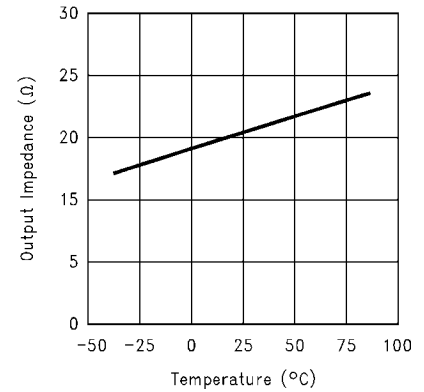

10110010

Output Resistance (VDBL) vs. Input Voltage

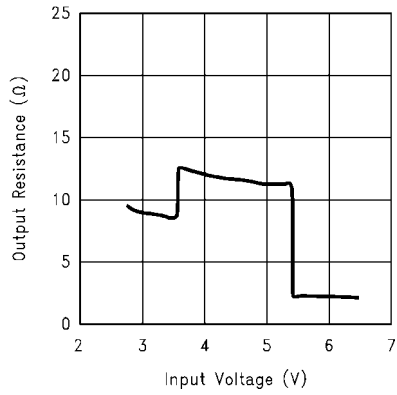

10110011

Output Resistance (VDBL) vs. Temperature

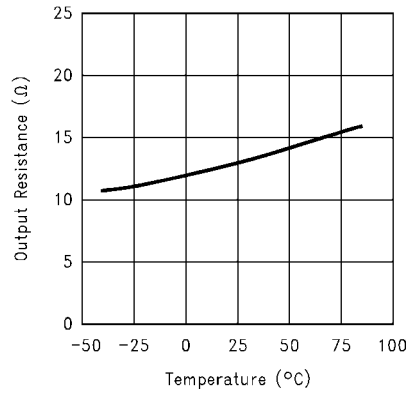

10110012

Switch Frequency vs. Temperature

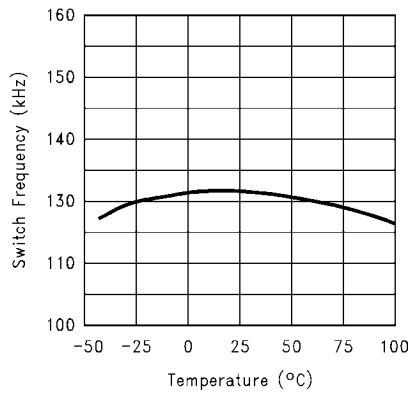

10110013

Line Transient Response (with 5mA Load)

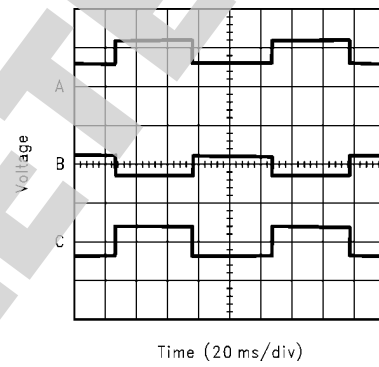

10110014

A: INPUT VOLTAGE: $V_{IN} = 3.2V$ to $6.0V$, $5V/div$
 B: OUTPUT VOLTAGE: $V_{PSW} = 100mV/div$
 C: OUTPUT VOLTAGE: $V_{NSW} = 100mV/div$

V_{05} Load Transient Response

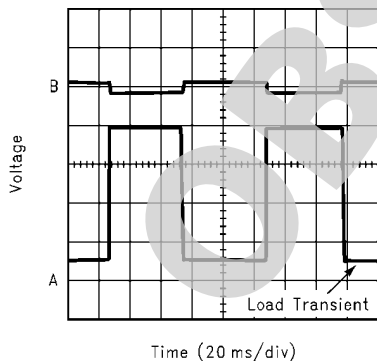

10110015

A: LOAD CURRENT: $I_{LOAD} = 5mA$ to $39.6mA$, $10mA/div$
 B: OUTPUT VOLTAGE: $V_{05} = 10mV/div$

V_{NSW} Load Transient Response

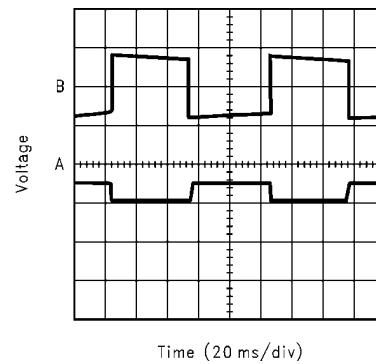

10110016

A: LOAD CURRENT: $I_{LOAD} = 4.4mA$ to $-9.4mA$, $10mA/div$
 B: OUTPUT VOLTAGE: $V_{NSW} = 50mV/div$

V_{PSW} and V_{NSW} Response to CE (with 5mA Load)

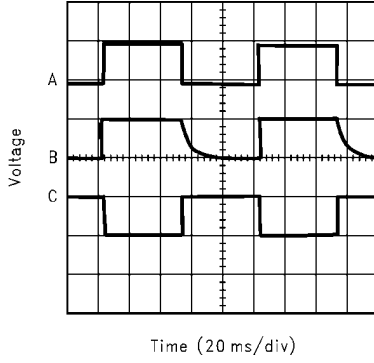

A: CE INPUT: 5V/div
 B: OUTPUT VOLTAGE: V_{PSW} : 5V/div
 C: OUTPUT VOLTAGE: V_{NSW} : 5V/div

10110017

V_{O5} Response to SDP (with 5mA Load)

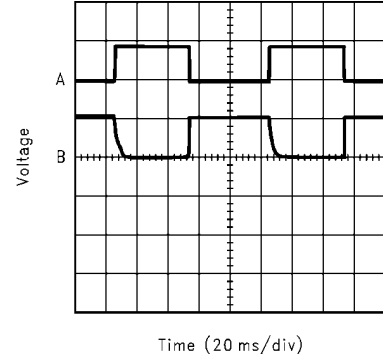

A: SDP INPUT: 5V/div
 B: OUTPUT VOLTAGE: 5V/div

10110018

V_{NSW} Response to SDP (with 5mA Load)

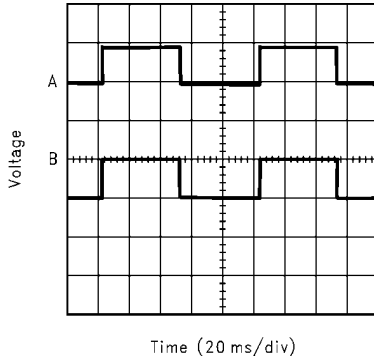

A: SDP INPUT: 5V/div
 B: OUTPUT VOLTAGE (V_{NSW}): 5V/div

10110019

V_{NSW} Response to SDN (with 5mA Load)

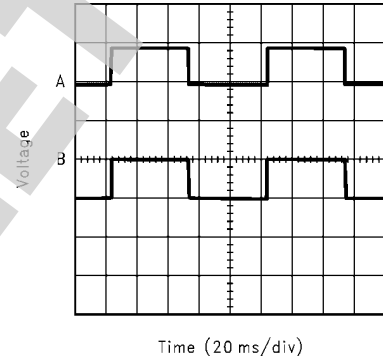

A: SDN INPUT: 5V/div
 B: OUTPUT VOLTAGE (V_{NSW}): 5V/div

10110020

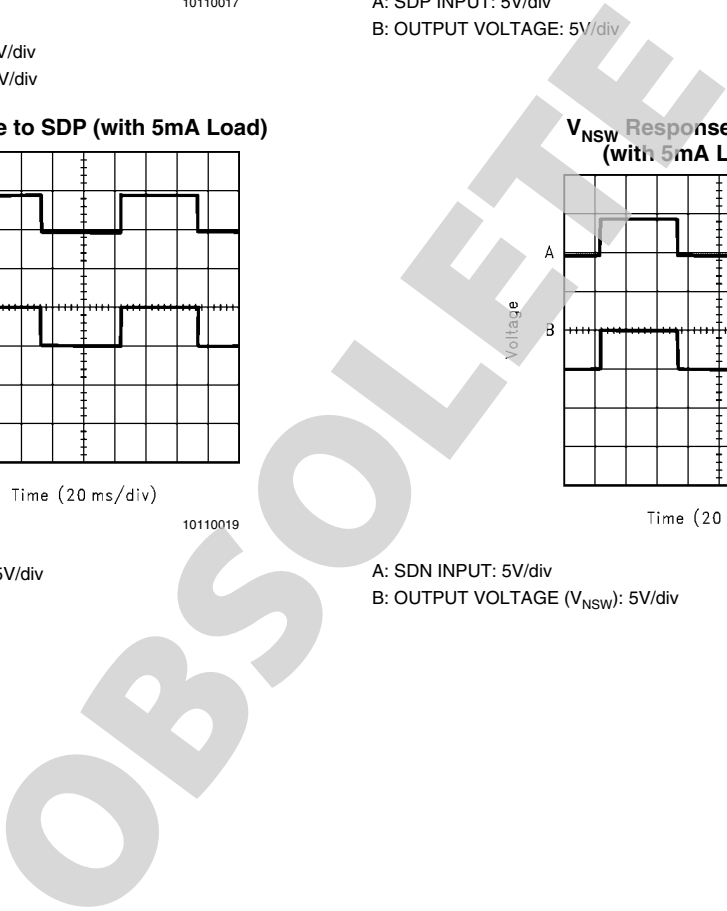

Detailed Device Description

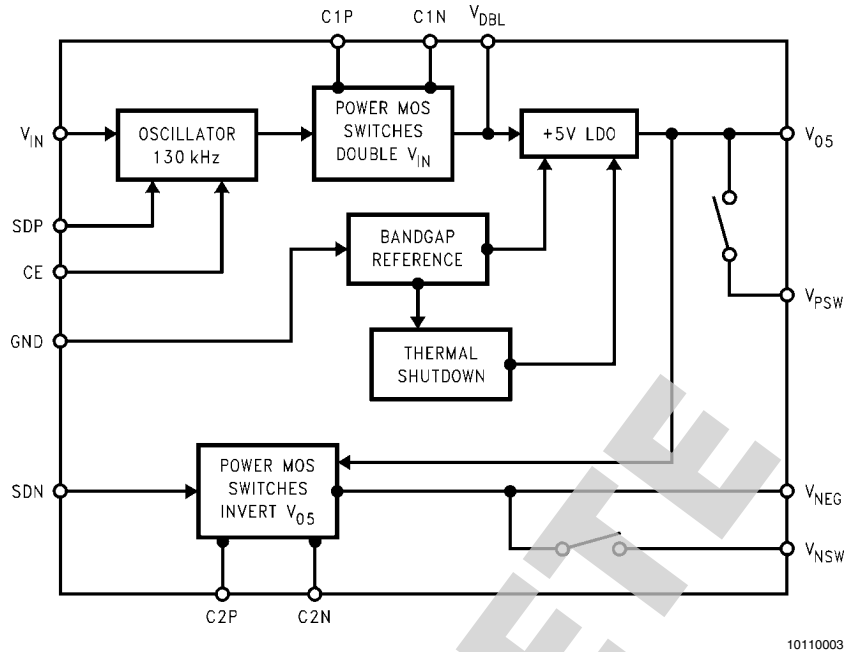

FIGURE 1. Functional Block Diagram

The LM2685 CMOS charge pump voltage converter operates as an input voltage doubler, +5V regulator and inverter for an input voltage in the range of +2.85V to +5.4V. It delivers maximum load currents of 50mA and 15mA for the regulated +5V and the inverted output voltages respectively, with an operating current of only 800 μ A. It also has a typical shutdown current of 6 μ A. All these performance qualities make the LM2685 an ideal device for battery powered systems.

The LM2685 has three main functional blocks: a voltage doubler, a low dropout (LDO) regulator, and a voltage inverter. Figure 1 shows the LM2685 functional block diagram.

VOLTAGE DOUBLER

The voltage doubler stage doubles the input voltage V_{IN} , within the range of +2.85V to +5.4V. For V_{IN} above 5.4V, the doubler shuts off and the input voltage is passed directly to V_{DBL} via an internal power switch.

The doubler contains four large CMOS switches which are switched in a sequence to double the input supply voltage. Figure 2 illustrates the voltage conversion scheme. When S2 and S4 are closed, C1 charges to the supply voltage V_{IN} . During this time interval, switches S1 and S3 are open. In the next time interval, S2 and S4 are opened at the same time, S1 and S3 are closed, the sum of the input voltage V_{IN} and the voltage across C1 gives the $2V_{IN}$ and the voltage across C2 gives the $2V_{IN}$ at V_{DBL} output. V_{DBL} supplies the LDO regulator. It is recommended not to load V_{DBL} when V_{O5} has a load of 50mA. For proper operation, the sum of V_{DBL} and V_{O5} loads must not be more than 50mA.

The Schottky diode D1 is only needed for start-up. The internal oscillator circuit uses the V_{DBL} and GND pins. The voltage across them must be larger than 1.8V to ensure the operation of the oscillator. During start-up, D1 is used to charge up the voltage at V_{DBL} pin to start the oscillator; it also protects the device from turning on its own parasitic diode and potentially latching up. The diode should have enough current carrying

capability to change capacitor C3 at start-up, as well as a low forward voltage to prevent the internal parasitic diode from turning on. A Schottky diode like 1N5817 can be used for most applications. If the input ramp is less than 10V/ms, a smaller schottky diode like MBR0520LT1 can be used to reduce the circuit size.

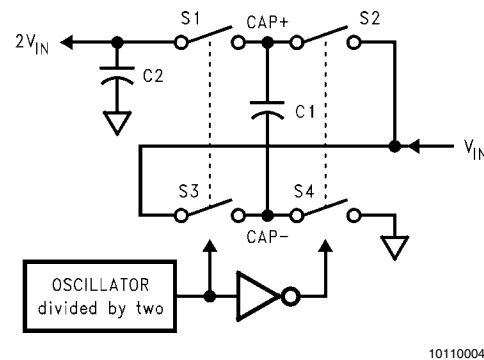

FIGURE 2. Voltage Doubler Principle

+5 LDO REGULATOR

V_{DBL} is the input to an LDO regulator that regulates it to a +5 output voltage at V_{O5} . V_{PSW} is tied to V_{O5} through a series switch PSW. The LDO output capacitor (4.7 μ F Tantalum) may be tied to either V_{O5} or V_{PSW} .

INVERTER

From the V_{O5} output, a -5V output is created at V_{NEG} by means of an inverting charge pump. This negative output is unregulated, meaning that its output will droop as the load current at V_{NEG} increases. The inverter contains four large CMOS switches which are in a sequence to invert the input supply voltage. Figure 3 illustrates the voltage conversion

scheme. When S1 and S3 are closed, C1 charges to the supply voltage V_{05} . During this time interval, switches S2 and S4 are open. In the second time interval, S1 and S3 are open; at the same time, S2 and S4 are closed, C1 is charging C2. After a number of cycles, the voltage across C2 will be pumped to V_{05} . Since the anode of C2 is connected to ground, the output at the cathode of C2 equals $-(V_{05})$ when there is no load current. The output voltage drop when a load is added is determined by the parasitic resistance ($R_{ds(on)}$) of the MOSFET switches and the ESR of the capacitors) and the charge transfer loss between capacitors.

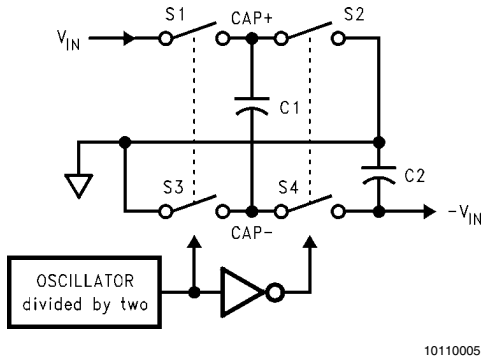

FIGURE 3. Voltage Inverter Principle

SHUTDOWN AND LOAD DISCONNECT

In addition to the nominal charge pump and regulator functions, the LM2685 features shutdown and load disconnect circuitry. CE (chip enable) and SDP (shutdown positive) perform the same task with opposite input polarities. When CE is low or SDP is high, all circuit blocks are disabled and V_{05} falls to ground potential. This is the same result as when the die temperature exceeds 150°C (typical), and the device's internal thermal shutdown is triggered.

Forcing SDN (shutdown negative) high disables only the inverting charge pump. The doubling charge pump and the LDO regulator continue to operate, so the V_{05} and the V_{PSW} remain at 5V.

The LM2685 incorporates two low impedance switches tied to the V_{05} and V_{NEG} outputs, because some special applications require load disconnect and this is achievable via the switches. Switch PSW connects V_{05} to V_{PSW} , and switch NSW connects V_{NEG} to V_{NSW} . In normal operation, these switches are closed, allowing 5V loads to be tied to either V_{05} or V_{PSW} and -5V loads to be tied to either V_{NEG} or V_{NSW} . Driving SDN high opens switch NSW only, while forcing CE low or SDP high, opens both the PSW and NSW.

Application Information

CAPACITOR SELECTION

The output resistance and ripple voltage are dependent on the capacitance and ESR values of the external capacitors.

VOLTAGE DOUBLER EXTERNAL CAPACITORS

The selection of capacitors are based on the specifications of the dropout voltage (which equals $I_{OUT} R_{OUT}$), the output voltage ripple, and the converter efficiency.

$$R_{OUT} = 2 R_{SW} + \frac{2}{f_{OSC} \times C_1} + 4 ESR_{C_1} + ESR_{C_3}$$

where R_{SW} is the sum of the ON resistance of the internal MOSFET switches as shown in Figure 2.

The peak-to-peak output voltage ripple is determined by the oscillator frequency, the capacitance and ESR of the capacitor C3.

$$V_{RIPPLE} = \frac{I_L}{f_{OSC} \times C_2} + 2 \times I_L \times ESR_{C_3}$$

High capacitance ($2.2\mu\text{F}$ to higher), low ESR capacitors can reduce the output resistance and the voltage ripple.

$$\text{Power efficiency of} = \frac{P_{OUT}}{P_{IN}} = \frac{I_L^2 R_L}{I_L^2 R_L + I_L^2 R_{OUT} + I_Q(V+)}$$

where $I_Q(V+)$ is the quiescent power loss of the IC device, and $I_L^2 R$ is the conversion loss associated with the switch on-resistance, the two external capacitors and their ESRs.

Low ESR capacitors (table to be referenced) are recommended to maximize efficiency, reduce the output voltage drop and voltage ripple.

+5 LDO REGULATOR EXTERNAL CAPACITORS

The voltage doubler output capacitor, C3, serves as the input capacitor of the +5 LDO regulator. The output capacitor C4, must meet the requirement for minimum amount of capacitance and appropriate ESR (Equivalent Serving Resistance) for proper operation. The ESR value must remain within the regions of stability as shown in Figure 4, Figure 5 and Figure 6 to ensure output's stability. A minimum capacitance of $1\mu\text{F}$ is required at the output. This can be increased without limit, but a $4.7\mu\text{F}$ tantalum capacitor is recommended for loads ranging up to the maximum specification. With lighter loads of less or equal to 10mA , ceramic capacitor of at least $1\mu\text{F}$ and ESR in the milliohms can be used. This has to be connected to V_{PSW} pin instead of the V_{05} pin.

Any output capacitor used should have a good tolerance over temperature for capacitance and ESR values. The larger the capacitor, with ESR within the stable region, the better the stability and noise performance.

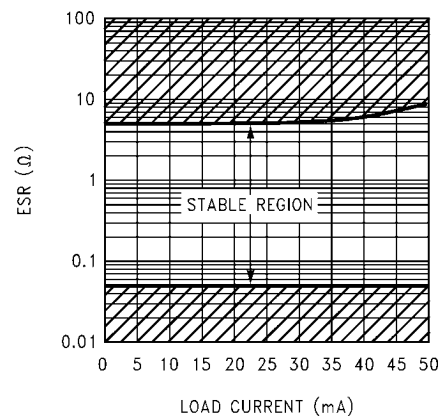

FIGURE 4. ESR Curve for $C_{OUT} = 2.2\mu\text{F}$

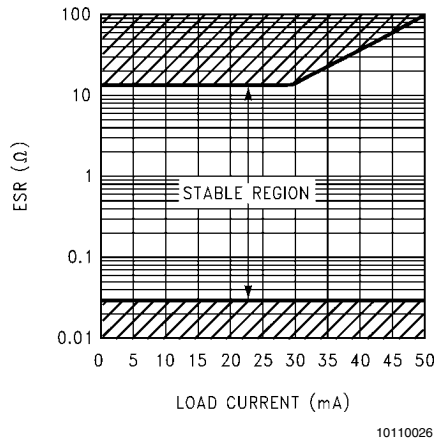

FIGURE 5. ESR Curve for $C_{OUT} = 4.7\mu F$

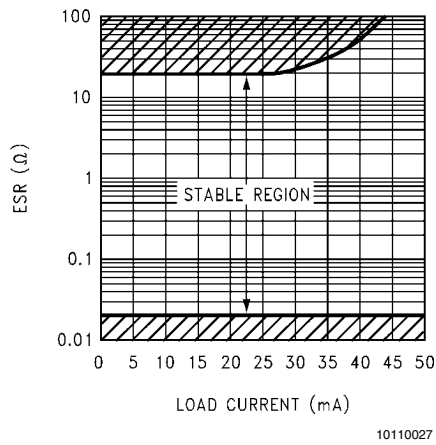
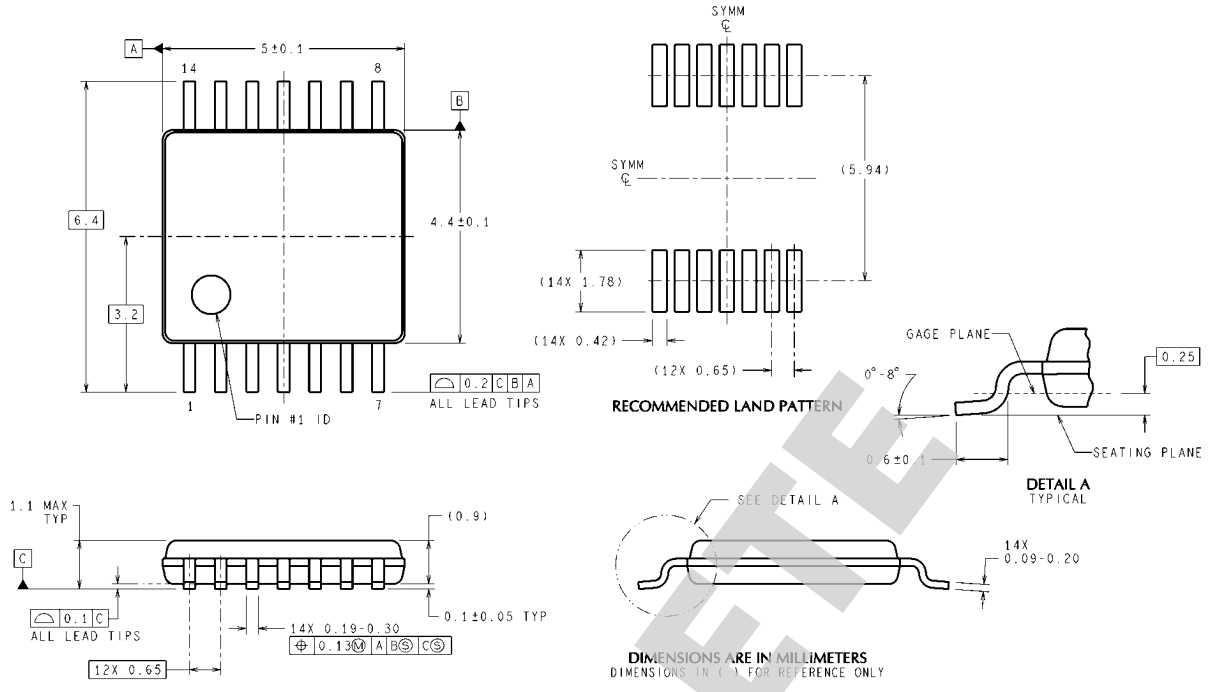

FIGURE 6. ESR Curve for $C_{OUT} = 10\mu F$

INVERTER EXTERNAL CAPACITORS

As discussed in the +5 LDO Regulator External Capacitors section, the output resistance and ripple voltage are dependent on the capacitance and ESR values of the external capacitors. A minimum of $1\mu F$ capacitor with good tolerance over temperature for capacitance and ESR values. The capacitance value can be increased without limit while still maintain high low ESR value. $2.2\mu F$ capacitors are recommended for the two external capacitors, C_2 and C_5 of the inverter.

Physical Dimensions inches (millimeters) unless otherwise noted



TSSOP-14 Package
14-Lead Thin Shrink Small-Outline Package
For Ordering, Refer to Ordering Information Table
NS Package Number MTC14

MTC14 (Rev D)

Notes

LM2685

OBSOLETE

Notes

For more National Semiconductor product information and proven design tools, visit the following Web sites at:
www.national.com

Products		Design Support	
Amplifiers	www.national.com/amplifiers	WEBENCH® Tools	www.national.com/webench
Audio	www.national.com/audio	App Notes	www.national.com/appnotes
Clock and Timing	www.national.com/timing	Reference Designs	www.national.com/refdesigns
Data Converters	www.national.com/adc	Samples	www.national.com/samples
Interface	www.national.com/interface	Eval Boards	www.national.com/evalboards
LVDS	www.national.com/lvds	Packaging	www.national.com/packaging
Power Management	www.national.com/power	Green Compliance	www.national.com/quality/green
Switching Regulators	www.national.com/switchers	Distributors	www.national.com/contacts
LDOs	www.national.com/ldo	Quality and Reliability	www.national.com/quality
LED Lighting	www.national.com/led	Feedback/Support	www.national.com/feedback
Voltage References	www.national.com/vref	Design Made Easy	www.national.com/easy
PowerWise® Solutions	www.national.com/powerwise	Applications & Markets	www.national.com/solutions
Serial Digital Interface (SDI)	www.national.com/sdi	Mil/Aero	www.national.com/milaero
Temperature Sensors	www.national.com/tempensors	SolarMagic™	www.national.com/solarmagic
PLL/VCO	www.national.com/wireless	PowerWise® Design University	www.national.com/training

THE CONTENTS OF THIS DOCUMENT ARE PROVIDED IN CONNECTION WITH NATIONAL SEMICONDUCTOR CORPORATION ("NATIONAL") PRODUCTS. NATIONAL MAKES NO REPRESENTATIONS OR WARRANTIES WITH RESPECT TO THE ACCURACY OR COMPLETENESS OF THE CONTENTS OF THIS PUBLICATION AND RESERVES THE RIGHT TO MAKE CHANGES TO SPECIFICATIONS AND PRODUCT DESCRIPTIONS AT ANY TIME WITHOUT NOTICE. NO LICENSE, WHETHER EXPRESS, IMPLIED, ARISING BY ESTOPPEL OR OTHERWISE, TO ANY INTELLECTUAL PROPERTY RIGHTS IS GRANTED BY THIS DOCUMENT.

TESTING AND OTHER QUALITY CONTROLS ARE USED TO THE EXTENT NATIONAL DEEMS NECESSARY TO SUPPORT NATIONAL'S PRODUCT WARRANTY. EXCEPT WHERE MANDATED BY GOVERNMENT REQUIREMENTS, TESTING OF ALL PARAMETERS OF EACH PRODUCT IS NOT NECESSARILY PERFORMED. NATIONAL ASSUMES NO LIABILITY FOR APPLICATIONS ASSISTANCE OR BUYER PRODUCT DESIGN. BUYERS ARE RESPONSIBLE FOR THEIR PRODUCTS AND APPLICATIONS USING NATIONAL COMPONENTS. PRIOR TO USING OR DISTRIBUTING ANY PRODUCTS THAT INCLUDE NATIONAL COMPONENTS, BUYERS SHOULD PROVIDE ADEQUATE DESIGN, TESTING AND OPERATING SAFEGUARDS.

EXCEPT AS PROVIDED IN NATIONAL'S TERMS AND CONDITIONS OF SALE FOR SUCH PRODUCTS, NATIONAL ASSUMES NO LIABILITY WHATSOEVER, AND NATIONAL DISCLAIMS ANY EXPRESS OR IMPLIED WARRANTY RELATING TO THE SALE AND/OR USE OF NATIONAL PRODUCTS INCLUDING LIABILITY OR WARRANTIES RELATING TO FITNESS FOR A PARTICULAR PURPOSE, MERCHANTABILITY, OR INFRINGEMENT OF ANY PATENT, COPYRIGHT OR OTHER INTELLECTUAL PROPERTY RIGHT.

LIFE SUPPORT POLICY

NATIONAL'S PRODUCTS ARE NOT AUTHORIZED FOR USE AS CRITICAL COMPONENTS IN LIFE SUPPORT DEVICES OR SYSTEMS WITHOUT THE EXPRESS PRIOR WRITTEN APPROVAL OF THE CHIEF EXECUTIVE OFFICER AND GENERAL COUNSEL OF NATIONAL SEMICONDUCTOR CORPORATION. As used herein:

Life support devices or systems are devices which (a) are intended for surgical implant into the body, or (b) support or sustain life and whose failure to perform when properly used in accordance with instructions for use provided in the labeling can be reasonably expected to result in a significant injury to the user. A critical component is any component in a life support device or system whose failure to perform can be reasonably expected to cause the failure of the life support device or system or to affect its safety or effectiveness.

National Semiconductor and the National Semiconductor logo are registered trademarks of National Semiconductor Corporation. All other brand or product names may be trademarks or registered trademarks of their respective holders.

Copyright© 2011 National Semiconductor Corporation

For the most current product information visit us at www.national.com



www.national.com

**National Semiconductor
Americas Technical
Support Center**
Email: support@nsc.com
Tel: 1-800-272-9959

**National Semiconductor Europe
Technical Support Center**
Email: europe.support@nsc.com

**National Semiconductor Asia
Pacific Technical Support Center**
Email: ap.support@nsc.com

**National Semiconductor Japan
Technical Support Center**
Email: jpn.feedback@nsc.com

IMPORTANT NOTICE

Texas Instruments Incorporated and its subsidiaries (TI) reserve the right to make corrections, modifications, enhancements, improvements, and other changes to its products and services at any time and to discontinue any product or service without notice. Customers should obtain the latest relevant information before placing orders and should verify that such information is current and complete. All products are sold subject to TI's terms and conditions of sale supplied at the time of order acknowledgment.

TI warrants performance of its hardware products to the specifications applicable at the time of sale in accordance with TI's standard warranty. Testing and other quality control techniques are used to the extent TI deems necessary to support this warranty. Except where mandated by government requirements, testing of all parameters of each product is not necessarily performed.

TI assumes no liability for applications assistance or customer product design. Customers are responsible for their products and applications using TI components. To minimize the risks associated with customer products and applications, customers should provide adequate design and operating safeguards.

TI does not warrant or represent that any license, either express or implied, is granted under any TI patent right, copyright, mask work right, or other TI intellectual property right relating to any combination, machine, or process in which TI products or services are used. Information published by TI regarding third-party products or services does not constitute a license from TI to use such products or services or a warranty or endorsement thereof. Use of such information may require a license from a third party under the patents or other intellectual property of the third party, or a license from TI under the patents or other intellectual property of TI.

Reproduction of TI information in TI data books or data sheets is permissible only if reproduction is without alteration and is accompanied by all associated warranties, conditions, limitations, and notices. Reproduction of this information with alteration is an unfair and deceptive business practice. TI is not responsible or liable for such altered documentation. Information of third parties may be subject to additional restrictions.

Resale of TI products or services with statements different from or beyond the parameters stated by TI for that product or service voids all express and any implied warranties for the associated TI product or service and is an unfair and deceptive business practice. TI is not responsible or liable for any such statements.

TI products are not authorized for use in safety-critical applications (such as life support) where a failure of the TI product would reasonably be expected to cause severe personal injury or death, unless officers of the parties have executed an agreement specifically governing such use. Buyers represent that they have all necessary expertise in the safety and regulatory ramifications of their applications, and acknowledge and agree that they are solely responsible for all legal, regulatory and safety-related requirements concerning their products and any use of TI products in such safety-critical applications, notwithstanding any applications-related information or support that may be provided by TI. Further, Buyers must fully indemnify TI and its representatives against any damages arising out of the use of TI products in such safety-critical applications.

TI products are neither designed nor intended for use in military/aerospace applications or environments unless the TI products are specifically designated by TI as military-grade or "enhanced plastic." Only products designated by TI as military-grade meet military specifications. Buyers acknowledge and agree that any such use of TI products which TI has not designated as military-grade is solely at the Buyer's risk, and that they are solely responsible for compliance with all legal and regulatory requirements in connection with such use.

TI products are neither designed nor intended for use in automotive applications or environments unless the specific TI products are designated by TI as compliant with ISO/TS 16949 requirements. Buyers acknowledge and agree that, if they use any non-designated products in automotive applications, TI will not be responsible for any failure to meet such requirements.

Following are URLs where you can obtain information on other Texas Instruments products and application solutions:

Products

Audio	www.ti.com/audio
Amplifiers	amplifier.ti.com
Data Converters	dataconverter.ti.com
DLP® Products	www.dlp.com
DSP	dsp.ti.com
Clocks and Timers	www.ti.com/clocks
Interface	interface.ti.com
Logic	logic.ti.com
Power Mgmt	power.ti.com
Microcontrollers	microcontroller.ti.com
RFID	www.ti-rfid.com
OMAP Mobile Processors	www.ti.com/omap
Wireless Connectivity	www.ti.com/wirelessconnectivity

Applications

Communications and Telecom	www.ti.com/communications
Computers and Peripherals	www.ti.com/computers
Consumer Electronics	www.ti.com/consumer-apps
Energy and Lighting	www.ti.com/energy
Industrial	www.ti.com/industrial
Medical	www.ti.com/medical
Security	www.ti.com/security
Space, Avionics and Defense	www.ti.com/space-avionics-defense
Transportation and Automotive	www.ti.com/automotive
Video and Imaging	www.ti.com/video

TI E2E Community Home Page

e2e.ti.com

Mailing Address: Texas Instruments, Post Office Box 655303, Dallas, Texas 75265
Copyright © 2011, Texas Instruments Incorporated