

DS92LV090A

DS92LV090A 9 Channel Bus LVDS Transceiver



Literature Number: SNLS025C

DS92LV090A

9 Channel Bus LVDS Transceiver

General Description

The DS92LV090A is one in a series of Bus LVDS transceivers designed specifically for the high speed, low power proprietary backplane or cable interfaces. The device operates from a single 3.3V power supply and includes nine differential line drivers and nine receivers. To minimize bus loading, the driver outputs and receiver inputs are internally connected. The separate I/O of the logic side allows for loop back support. The device also features a flow through pin out which allows easy PCB routing for short stubs between its pins and the connector.

The driver translates 3V TTL levels (single-ended) to differential Bus LVDS (BLVDS) output levels. This allows for high speed operation, while consuming minimal power with reduced EMI. In addition, the differential signaling provides common mode noise rejection of $\pm 1V$.

The receiver threshold is less than ± 100 mV over a $\pm 1V$ common mode range and translates the differential Bus LVDS to standard (TTL/CMOS) levels. (See Applications Information Section for more details.)

Features

- Bus LVDS Signaling
- 3.2 nanosecond propagation delay max
- Chip to Chip skew ± 800 ps
- Low power CMOS design
- High Signaling Rate Capability (above 100 Mbps)
- 0.1V to 2.3V Common Mode Range for $V_{ID} = 200$ mV
- ± 100 mV Receiver Sensitivity
- Supports open and terminated failsafe on port pins
- 3.3V operation
- Glitch free power up/down (Driver & Receiver disabled)
- Light Bus Loading (5 pF typical) per Bus LVDS load
- Designed for Double Termination Applications
- Balanced Output Impedance
- Product offered in 64 pin TQFP package
- High impedance Bus pins on power off ($V_{CC} = 0V$)
- Driver Channel to Channel skew (same device) 230ps typical
- Receiver Channel to Channel skew (same device) 370ps typical

Simplified Functional Diagram

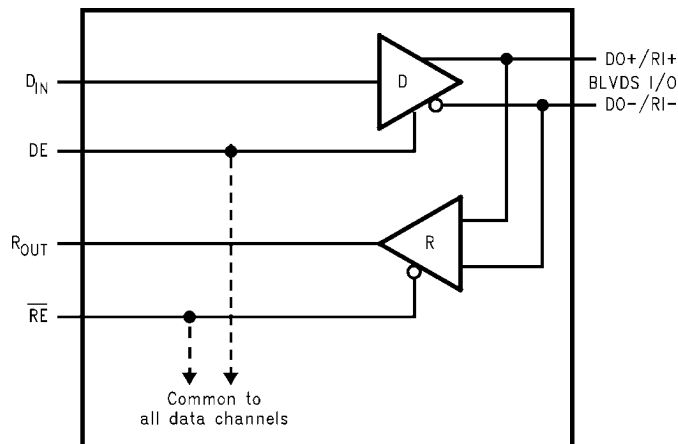

1001101

Connection Diagram

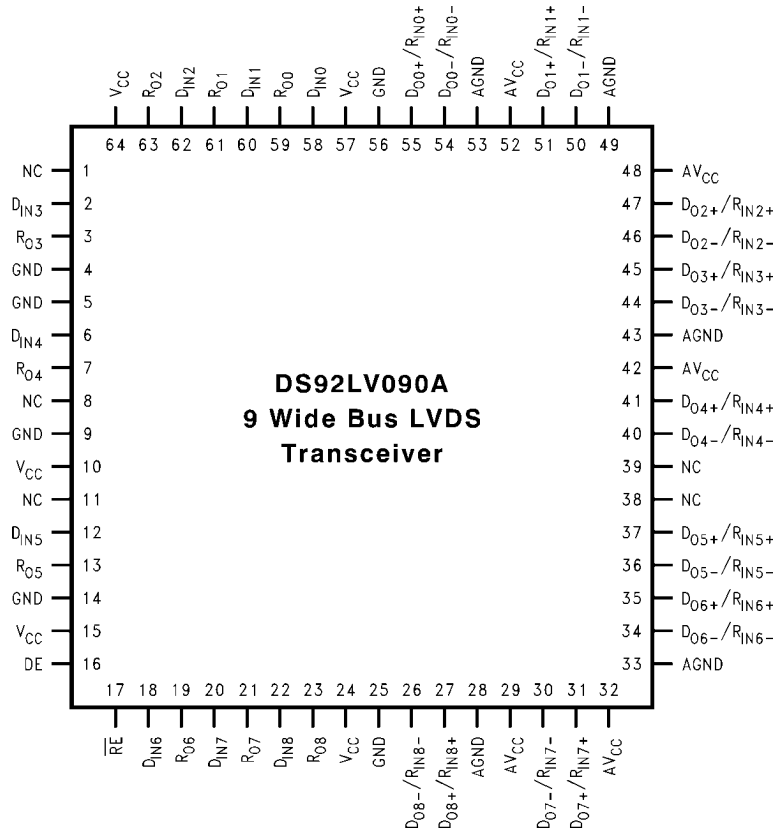

10011102

Top View
Order Number DS92LV090ATVEH
See NS Package Number VEH064DB

Pin Descriptions

Pin Name	Pin #	Input/Output	Descriptions
DO+/RI+	27, 31, 35, 37, 41, 45, 47, 51, 55	I/O	True Bus LVDS Driver Outputs and Receiver Inputs.
DO-/RI-	26, 30, 34, 36, 40, 44, 46, 50, 54	I/O	Complimentary Bus LVDS Driver Outputs and Receiver Inputs.
D _{IN}	2, 6, 12, 18, 20, 22, 58, 60, 62	I	TTL Driver Input.
RO	3, 7, 13, 19, 21, 23, 59, 61, 63	O	TTL Receiver Output.
RE	17	I	Receiver Enable TTL Input (Active Low).
DE	16	I	Driver Enable TTL Input (Active High).
GND	4, 5, 9, 14, 25, 56	Power	Ground for digital circuitry (must connect to GND on PC board). These pins connected internally.
V _{CC}	10, 15, 24, 57, 64	Power	V _{CC} for digital circuitry (must connect to V _{CC} on PC board). These pins connected internally.
AGND	28, 33, 43, 49, 53	Power	Ground for analog circuitry (must connect to GND on PC board). These pins connected internally.
AV _{CC}	29, 32, 42, 48, 52	Power	Analog V _{CC} (must connect to V _{CC} on PC board). These pins connected internally.
NC	1, 8, 11, 38, 39	N/A	Leave open circuit, do not connect.

Absolute Maximum Ratings (Notes 1, 2)

If Military/Aerospace specified devices are required, please contact the National Semiconductor Sales Office/Distributors for availability and specifications.

Supply Voltage (V_{CC})	4.0V
Enable Input Voltage (DE, \overline{RE})	-0.3V to ($V_{CC} + 0.3V$)
Driver Input Voltage (D_{IN})	-0.3V to ($V_{CC} + 0.3V$)
Receiver Output Voltage (R_{OUT})	-0.3V to ($V_{CC} + 0.3V$)
Bus Pin Voltage (DO/RI \pm)	-0.3V to +3.9V
ESD (HBM 1.5 k Ω , 100 pF)	>4.5 kV
Driver Short Circuit Duration	momentary
Receiver Short Circuit Duration	momentary
Maximum Package Power Dissipation at 25°C	
TQFP	1.74 W
Derate TQFP Package	13.9 mW/°C
θ_{ja}	71.7°C/W

θ_{jc}	10.9°C/W
Junction Temperature	+150°C
Storage Temperature Range	-65°C to +150°C
Lead Temperature (Soldering, 4 sec.)	260°C

Recommended Operating Conditions

	Min	Max	Units
Supply Voltage (V_{CC})	3.0	3.6	V
Receiver Input Voltage	0.0	2.4	V
Operating Free Air Temperature	-40	+85	°C
Maximum Input Edge Rate (Note 6)(20% to 80%)			$\Delta t/\Delta V$
Data		1.0	ns/V
Control		3.0	ns/V

DC Electrical Characteristics

Over recommended operating supply voltage and temperature ranges unless otherwise specified (Notes 2, 3)

Symbol	Parameter	Conditions	Pin	Min	Typ	Max	Units
V_{OD}	Output Differential Voltage	$R_L = 27\Omega$, Figure 1	DO+/RI+, DO-/RI-	240	300	460	mV
ΔV_{OD}	V_{OD} Magnitude Change					27	mV
V_{OS}	Offset Voltage			1.1	1.3	1.5	V
ΔV_{OS}	Offset Magnitude Change				5	10	mV
V_{OH}	Driver Output High Voltage	$R_L = 27\Omega$			1.4	1.65	V
V_{OL}	Driver Output Low Voltage	$R_L = 27\Omega$		0.95	1.1		V
I_{OSD}	Output Short Circuit Current (Note 10)	$V_{OD} = 0V$, DE = V_{CC} , Driver outputs shorted together			36	65	mA
V_{OH}	Voltage Output High (Note 11)	$V_{ID} = +300$ mV	R_{OUT}	$V_{CC} - 0.2$			V
		Inputs Open		$V_{CC} - 0.2$			V
		Inputs Terminated, $R_L = 27\Omega$		$V_{CC} - 0.2$			V
V_{OL}	Voltage Output Low	$I_{OL} = 2.0$ mA, $V_{ID} = -300$ mV			0.05	0.075	V
I_{OD}	Receiver Output Dynamic Current (Note 10)	$V_{ID} = 300$ mV, $V_{OUT} = V_{CC} - 1.0V$		-110	75		mA
		$V_{ID} = -300$ mV, $V_{OUT} = 1.0V$			75	110	mA
V_{TH}	Input Threshold High	DE = 0V, $V_{CM} = 1.5V$	DO+/RI+, DO-/RI-			+100	mV
V_{TL}	Input Threshold Low			-100			mV
V_{CMR}	Receiver Common Mode Range			$ V_{ID} /2$		2.4 - $V_{ID} /2$	V
I_{IN}	Input Current	DE = 0V, $\overline{RE} = 2.4V$, $V_{IN} = +2.4V$ or 0V		-20	± 1	+20	μA
		$V_{CC} = 0V$, $V_{IN} = +2.4V$ or 0V		-20	± 1	+20	μA
V_{IH}	Minimum Input High Voltage		D_{IN} , DE, \overline{RE}	2.0		V_{CC}	V
V_{IL}	Maximum Input Low Voltage			GND		0.8	V
I_{IH}	Input High Current	$V_{IN} = V_{CC}$ or 2.4V		-20	± 10	+20	μA
I_{IL}	Input Low Current	$V_{IN} = GND$ or 0.4V		-20	± 10	+20	μA
V_{CL}	Input Diode Clamp Voltage	$I_{CLAMP} = -18$ mA		-1.5	-0.8		V

Symbol	Parameter	Conditions	Pin	Min	Typ	Max	Units
I_{CCD}	Power Supply Current Drivers Enabled, Receivers Disabled	No Load, $DE = \overline{RE} = V_{CC}$, $DIN = V_{CC}$ or GND	V_{CC}		55	80	mA
I_{CCR}	Power Supply Current Drivers Disabled, Receivers Enabled	$DE = \overline{RE} = 0V$, $V_{ID} = \pm 300mV$			73	80	mA
I_{CCZ}	Power Supply Current, Drivers and Receivers TRI- STATE®	$DE = 0V$; $\overline{RE} = V_{CC}$, $DIN = V_{CC}$ or GND			35	80	mA
I_{CC}	Power Supply Current, Drivers and Receivers Enabled	$DE = V_{CC}$; $\overline{RE} = 0V$, $DIN = V_{CC}$ or GND, $R_L = 27\Omega$			170	210	mA
I_{OFF}	Power Off Leakage Current	$V_{CC} = 0V$ or OPEN, D_{IN} , DE , $\overline{RE} = 0V$ or OPEN, $V_{APPLIED} = 3.6V$ (Port Pins)	DO+/RI+, DO-/RI-	-20		+20	μA
C_{OUTPUT}	Capacitance @ Bus Pins		DO+/RI+, DO-/RI-		5		pF
C_{OUTPUT}	Capacitance @ R_{OUT}		R_{OUT}		7		pF

AC Electrical Characteristics

Over recommended operating supply voltage and temperature ranges unless otherwise specified (Note 6)

Symbol	Parameter	Conditions	Min	Typ	Max	Units	
DIFFERENTIAL DRIVER TIMING REQUIREMENTS							
t_{PHLD}	Differential Prop. Delay High to Low (Note 8)	$R_L = 27\Omega$, Figures 2, 3, $C_L = 10\text{ pF}$	0.6	1.4	2.2	ns	
t_{PLHD}	Differential Prop. Delay Low to High (Note 8)		0.6	1.4	2.2	ns	
t_{SKD1}	Differential Skew $ t_{PHLD} - t_{PLHD} $ (Note 9)			80		ps	
t_{SKD2}	Chip to Chip Skew (Note 12)				1.6	ns	
t_{SKD3}	Channel to Channel Skew (Note 13)			0.25	0.45	ns	
t_{TLH}	Transition Time Low to High				0.6	1.2	ns
t_{THL}	Transition Time High to Low				0.5	1.2	ns
t_{PHZ}	Disable Time High to Z		$R_L = 27\Omega$, Figures 4, 5, $C_L = 10\text{ pF}$		3	8	ns
t_{PLZ}	Disable Time Low to Z			3	8	ns	
t_{PZH}	Enable Time Z to High			3	8	ns	
t_{PZL}	Enable Time Z to Low			3	8	ns	
DIFFERENTIAL RECEIVER TIMING REQUIREMENTS							
t_{PHLD}	Differential Prop. Delay High to Low (Note 8)	$R_L = 50\Omega$, Figures 6, 7, $C_L = 35\text{ pF}$	1.6	2.4	3.2	ns	
t_{PLHD}	Differential Prop Delay Low to High (Note 8)		1.6	2.4	3.2	ns	
t_{SDK1}	Differential Skew $ t_{PHLD} - t_{PLHD} $ (Note 9)			80		ps	
t_{SDK2}	Chip to Chip Skew (Note 12)				1.6	ns	
t_{SDK3}	Channel to Channel Skew (Note 13)			0.35	0.60	ns	
t_{TLH}	Transition Time Low to High				1.5	2.5	ns
t_{THL}	Transition Time High to Low			1.5	2.5	ns	
t_{PHZ}	Disable Time High to Z	$R_L = 500\Omega$, Figures 8, 9, $C_L = 35\text{ pF}$		4.5	10	ns	
t_{PLZ}	Disable Time Low to Z			3.5	8	ns	
t_{PZH}	Enable Time Z to High			3.5	8	ns	
t_{PZL}	Enable Time Z to Low			3.5	8	ns	

Note 1: "Absolute Maximum Ratings" are those values beyond which the safety of the device cannot be guaranteed. They are not meant to imply that the devices should be operated at these limits. The table of "Electrical Characteristics" provides conditions for actual device operation.

Note 2: All currents into device pins are positive; all currents out of device pins are negative. All voltages are referenced to ground unless otherwise specified except V_{OD} , ΔV_{OD} and V_{ID} .

Note 3: All typicals are given for $V_{CC} = +3.3V$ and $T_A = +25^\circ C$, unless otherwise stated.

Note 4: ESD Rating: HBM (1.5 k Ω , 100 pF) > 4.5 kV EIAJ (0 Ω , 200 pF) > 300V.

Note 5: C_L includes probe and fixture capacitance.

Note 6: Generator waveforms for all tests unless otherwise specified: $f = 25\text{ MHz}$, $Z_O = 50\Omega$, $t_r, t_f = <1.0\text{ ns}$ (0%–100%). To ensure fastest propagation delay and minimum skew, data input edge rates should be equal to or faster than 1ns/V; control signals equal to or faster than 3ns/V. In general, the faster the input edge rate, the better the AC performance.

Note 7: The DS92LV090A functions within datasheet specification when a resistive load is applied to the driver outputs.

Note 8: Propagation delays are guaranteed by design and characterization.

Note 9: $t_{SKD1} |t_{PHLD} - t_{PLHD}|$ is the worse case skew between any channel and any device over recommended operation conditions.

Note 10: Only one output at a time should be shorted, do not exceed maximum package power dissipation capacity.

Note 11: V_{OH} failsafe terminated test performed with 27 Ω connected between RI+ and RI- inputs. No external voltage is applied.

Note 12: Chip to Chip skew is the difference in differential propagation delay between any channels of any devices, either edge.

Note 13: Channel to Channel skew is the difference in driver output or receiver output propagation delay between any channels within a device, either edge.

Applications Information

General application guidelines and hints may be found in the following application notes: AN-808, AN-903, AN-971, AN-977, and AN-1108.

There are a few common practices which should be implied when designing PCB for Bus LVDS signaling. Recommended practices are:

- Use at least 4 PCB board layer (Bus LVDS signals, ground, power and TTL signals).
 - Keep drivers and receivers as close to the (Bus LVDS port side) connector as possible.
 - Bypass each Bus LVDS device and also use distributed bulk capacitance between power planes. Surface mount capacitors placed close to power and ground pins work best. Two or three high frequency, multi-layer ceramic (MLC) surface mount (0.1 μ F, 0.01 μ F, 0.001 μ F) in parallel should be used between each V_{CC} and ground. The capacitors should be as close as possible to the V_{CC} pin. Multiple vias should be used to connect V_{CC} and Ground planes to the pads of the by-pass capacitors. In addition, randomly distributed by-pass capacitors should be used.
 - Use the termination resistor which best matches the differential impedance of your transmission line.
 - Leave unused Bus LVDS receiver inputs open (floating). Limit traces on unused inputs to <0.5 inches.
 - Isolate TTL signals from Bus LVDS signals
- MEDIA (CONNECTOR or BACKPLANE) SELECTION:**
- Use controlled impedance media. The backplane and connectors should have a matched differential impedance.

Test Circuits and Timing Waveforms

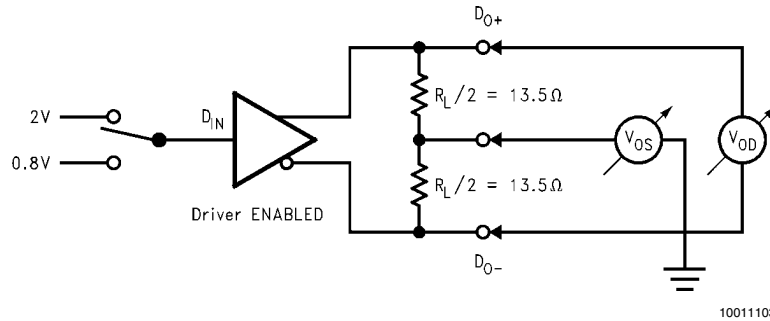

FIGURE 1. Differential Driver DC Test Circuit

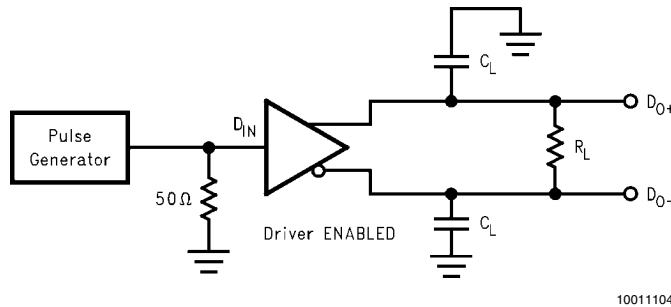

FIGURE 2. Differential Driver Propagation Delay and Transition Time Test Circuit

TABLE 1. Functional Table

MODE SELECTED	DE	\overline{RE}
DRIVER MODE	H	H
RECEIVER MODE	L	L
TRI-STATE MODE	L	H
LOOP BACK MODE	H	L

TABLE 2. Transmitter Mode

INPUTS		OUTPUTS	
DE	D_{IN}	$DO+$	$DO-$
H	L	L	H
H	H	H	L
H	$0.8V < D_{IN} < 2.0V$	X	X
L	X	Z	Z

TABLE 3. Receiver Mode

INPUTS		OUTPUT
\overline{RE}	$(RI+) - (RI-)$	
L	$L (< -100 \text{ mV})$	L
L	$H (> +100 \text{ mV})$	H
L	$-100 \text{ mV} < V_{ID} < +100 \text{ mV}$	X
H	X	Z

X = High or Low logic state
 L = Low state
 Z = High impedance state
 H = High state

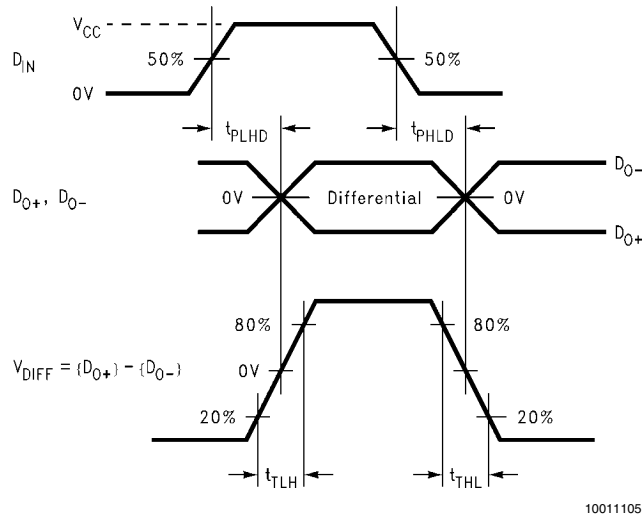

10011105

FIGURE 3. Differential Driver Propagation Delay and Transition Time Waveforms

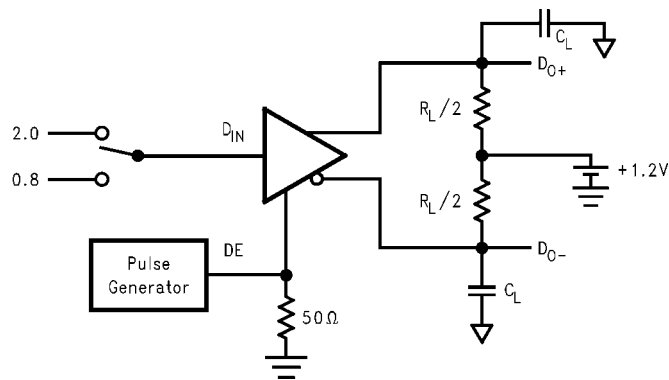

10011106

FIGURE 4. Driver TRI-STATE Delay Test Circuit

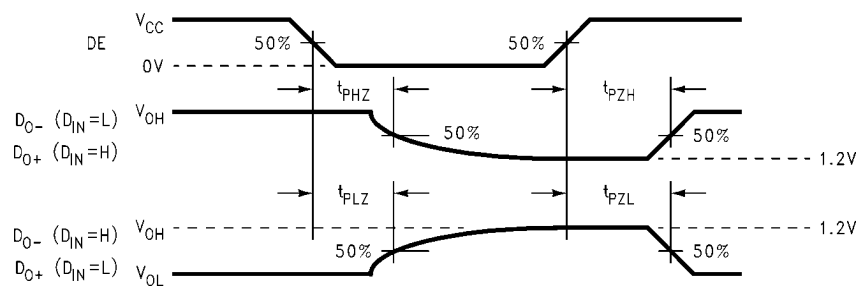

10011107

FIGURE 5. Driver TRI-STATE Delay Waveforms

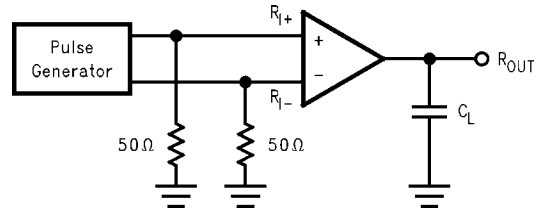

10011108

FIGURE 6. Receiver Propagation Delay and Transition Time Test Circuit

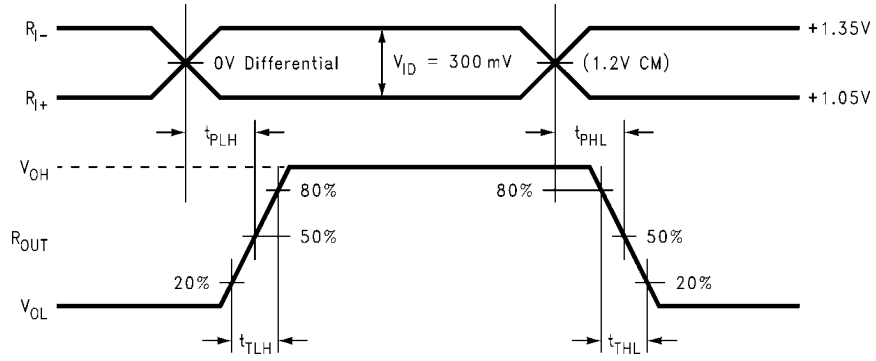

10011109

FIGURE 7. Receiver Propagation Delay and Transition Time Waveforms

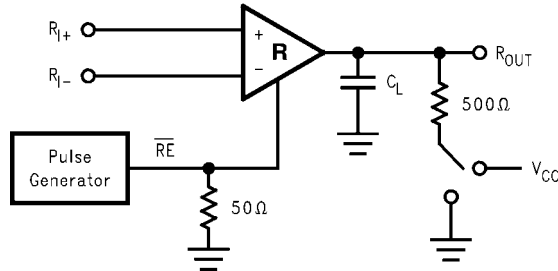

10011110

FIGURE 8. Receiver TRI-STATE Delay Test Circuit

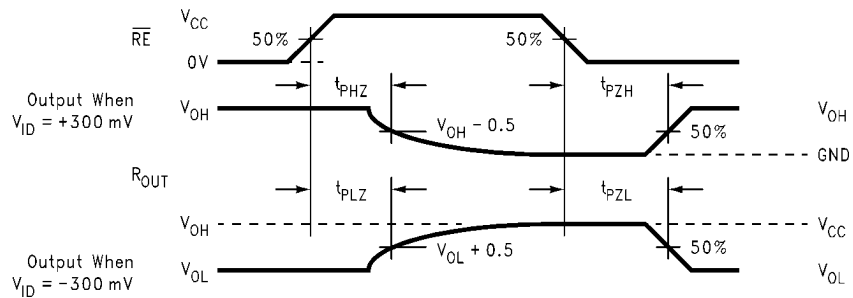

10011111

FIGURE 9. Receiver TRI-STATE Delay Waveforms

Typical Bus Application Configurations

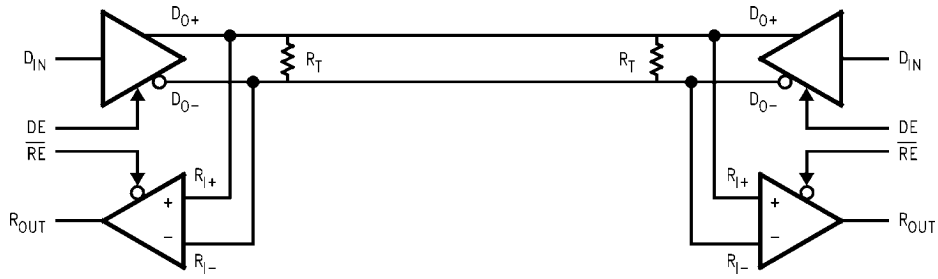

Bi-Directional Half-Duplex Point-to-Point Applications

10011112

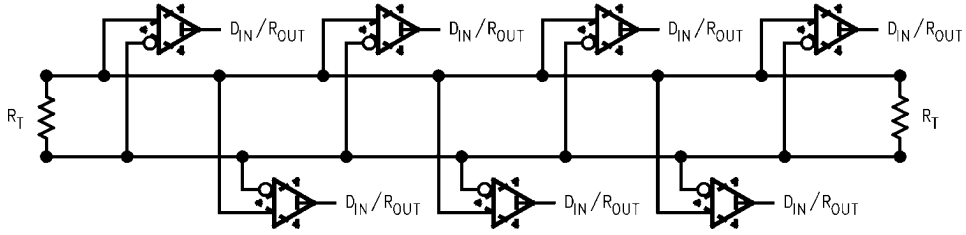

Multi-Point Bus Applications

10011113

Physical Dimensions inches (millimeters) unless otherwise noted

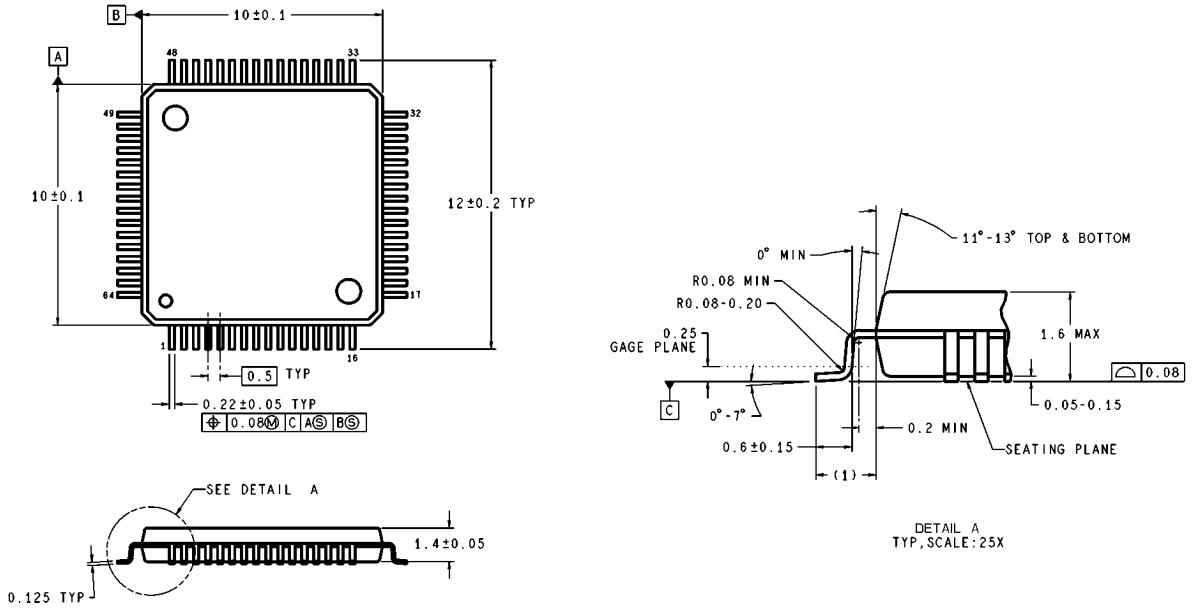

DIMENSIONS ARE IN MILLIMETERS

VEH64A (Rev C)

64-Lead Molded TQFP Package
Order Number DS92LV090ATVEH
NS Package Number VEH064DB

Notes

Notes

For more National Semiconductor product information and proven design tools, visit the following Web sites at:

Products		Design Support	
Amplifiers	www.national.com/amplifiers	WEBENCH	www.national.com/webench
Audio	www.national.com/audio	Analog University	www.national.com/AU
Clock Conditioners	www.national.com/timing	App Notes	www.national.com/appnotes
Data Converters	www.national.com/adc	Distributors	www.national.com/contacts
Displays	www.national.com/displays	Green Compliance	www.national.com/quality/green
Ethernet	www.national.com/ethernet	Packaging	www.national.com/packaging
Interface	www.national.com/interface	Quality and Reliability	www.national.com/quality
LVDS	www.national.com/lvds	Reference Designs	www.national.com/refdesigns
Power Management	www.national.com/power	Feedback	www.national.com/feedback
Switching Regulators	www.national.com/switchers		
LDOs	www.national.com/ldo		
LED Lighting	www.national.com/led		
PowerWise	www.national.com/powerwise		
Serial Digital Interface (SDI)	www.national.com/sdi		
Temperature Sensors	www.national.com/tempsensors		
Wireless (PLL/VCO)	www.national.com/wireless		

THE CONTENTS OF THIS DOCUMENT ARE PROVIDED IN CONNECTION WITH NATIONAL SEMICONDUCTOR CORPORATION ("NATIONAL") PRODUCTS. NATIONAL MAKES NO REPRESENTATIONS OR WARRANTIES WITH RESPECT TO THE ACCURACY OR COMPLETENESS OF THE CONTENTS OF THIS PUBLICATION AND RESERVES THE RIGHT TO MAKE CHANGES TO SPECIFICATIONS AND PRODUCT DESCRIPTIONS AT ANY TIME WITHOUT NOTICE. NO LICENSE, WHETHER EXPRESS, IMPLIED, ARISING BY ESTOPPEL OR OTHERWISE, TO ANY INTELLECTUAL PROPERTY RIGHTS IS GRANTED BY THIS DOCUMENT.

TESTING AND OTHER QUALITY CONTROLS ARE USED TO THE EXTENT NATIONAL DEEMS NECESSARY TO SUPPORT NATIONAL'S PRODUCT WARRANTY. EXCEPT WHERE MANDATED BY GOVERNMENT REQUIREMENTS, TESTING OF ALL PARAMETERS OF EACH PRODUCT IS NOT NECESSARILY PERFORMED. NATIONAL ASSUMES NO LIABILITY FOR APPLICATIONS ASSISTANCE OR BUYER PRODUCT DESIGN. BUYERS ARE RESPONSIBLE FOR THEIR PRODUCTS AND APPLICATIONS USING NATIONAL COMPONENTS. PRIOR TO USING OR DISTRIBUTING ANY PRODUCTS THAT INCLUDE NATIONAL COMPONENTS, BUYERS SHOULD PROVIDE ADEQUATE DESIGN, TESTING AND OPERATING SAFEGUARDS.

EXCEPT AS PROVIDED IN NATIONAL'S TERMS AND CONDITIONS OF SALE FOR SUCH PRODUCTS, NATIONAL ASSUMES NO LIABILITY WHATSOEVER, AND NATIONAL DISCLAIMS ANY EXPRESS OR IMPLIED WARRANTY RELATING TO THE SALE AND/OR USE OF NATIONAL PRODUCTS INCLUDING LIABILITY OR WARRANTIES RELATING TO FITNESS FOR A PARTICULAR PURPOSE, MERCHANTABILITY, OR INFRINGEMENT OF ANY PATENT, COPYRIGHT OR OTHER INTELLECTUAL PROPERTY RIGHT.

LIFE SUPPORT POLICY

NATIONAL'S PRODUCTS ARE NOT AUTHORIZED FOR USE AS CRITICAL COMPONENTS IN LIFE SUPPORT DEVICES OR SYSTEMS WITHOUT THE EXPRESS PRIOR WRITTEN APPROVAL OF THE CHIEF EXECUTIVE OFFICER AND GENERAL COUNSEL OF NATIONAL SEMICONDUCTOR CORPORATION. As used herein:

Life support devices or systems are devices which (a) are intended for surgical implant into the body, or (b) support or sustain life and whose failure to perform when properly used in accordance with instructions for use provided in the labeling can be reasonably expected to result in a significant injury to the user. A critical component is any component in a life support device or system whose failure to perform can be reasonably expected to cause the failure of the life support device or system or to affect its safety or effectiveness.

National Semiconductor and the National Semiconductor logo are registered trademarks of National Semiconductor Corporation. All other brand or product names may be trademarks or registered trademarks of their respective holders.

Copyright© 2007 National Semiconductor Corporation

For the most current product information visit us at www.national.com



**National Semiconductor
Americas Customer
Support Center**
Email:
new.feedback@nsc.com
Tel: 1-800-272-9959

**National Semiconductor Europe
Customer Support Center**
Fax: +49 (0) 180-530-85-86
Email: europe.support@nsc.com
Deutsch Tel: +49 (0) 69 9508 6208
English Tel: +49 (0) 870 24 0 2171
Français Tel: +33 (0) 1 41 91 8790

**National Semiconductor Asia
Pacific Customer Support Center**
Email: ap.support@nsc.com

**National Semiconductor Japan
Customer Support Center**
Fax: 81-3-5639-7507
Email: jpn.feedback@nsc.com
Tel: 81-3-5639-7560

IMPORTANT NOTICE

Texas Instruments Incorporated and its subsidiaries (TI) reserve the right to make corrections, modifications, enhancements, improvements, and other changes to its products and services at any time and to discontinue any product or service without notice. Customers should obtain the latest relevant information before placing orders and should verify that such information is current and complete. All products are sold subject to TI's terms and conditions of sale supplied at the time of order acknowledgment.

TI warrants performance of its hardware products to the specifications applicable at the time of sale in accordance with TI's standard warranty. Testing and other quality control techniques are used to the extent TI deems necessary to support this warranty. Except where mandated by government requirements, testing of all parameters of each product is not necessarily performed.

TI assumes no liability for applications assistance or customer product design. Customers are responsible for their products and applications using TI components. To minimize the risks associated with customer products and applications, customers should provide adequate design and operating safeguards.

TI does not warrant or represent that any license, either express or implied, is granted under any TI patent right, copyright, mask work right, or other TI intellectual property right relating to any combination, machine, or process in which TI products or services are used. Information published by TI regarding third-party products or services does not constitute a license from TI to use such products or services or a warranty or endorsement thereof. Use of such information may require a license from a third party under the patents or other intellectual property of the third party, or a license from TI under the patents or other intellectual property of TI.

Reproduction of TI information in TI data books or data sheets is permissible only if reproduction is without alteration and is accompanied by all associated warranties, conditions, limitations, and notices. Reproduction of this information with alteration is an unfair and deceptive business practice. TI is not responsible or liable for such altered documentation. Information of third parties may be subject to additional restrictions.

Resale of TI products or services with statements different from or beyond the parameters stated by TI for that product or service voids all express and any implied warranties for the associated TI product or service and is an unfair and deceptive business practice. TI is not responsible or liable for any such statements.

TI products are not authorized for use in safety-critical applications (such as life support) where a failure of the TI product would reasonably be expected to cause severe personal injury or death, unless officers of the parties have executed an agreement specifically governing such use. Buyers represent that they have all necessary expertise in the safety and regulatory ramifications of their applications, and acknowledge and agree that they are solely responsible for all legal, regulatory and safety-related requirements concerning their products and any use of TI products in such safety-critical applications, notwithstanding any applications-related information or support that may be provided by TI. Further, Buyers must fully indemnify TI and its representatives against any damages arising out of the use of TI products in such safety-critical applications.

TI products are neither designed nor intended for use in military/aerospace applications or environments unless the TI products are specifically designated by TI as military-grade or "enhanced plastic." Only products designated by TI as military-grade meet military specifications. Buyers acknowledge and agree that any such use of TI products which TI has not designated as military-grade is solely at the Buyer's risk, and that they are solely responsible for compliance with all legal and regulatory requirements in connection with such use.

TI products are neither designed nor intended for use in automotive applications or environments unless the specific TI products are designated by TI as compliant with ISO/TS 16949 requirements. Buyers acknowledge and agree that, if they use any non-designated products in automotive applications, TI will not be responsible for any failure to meet such requirements.

Following are URLs where you can obtain information on other Texas Instruments products and application solutions:

Products

Audio	www.ti.com/audio
Amplifiers	amplifier.ti.com
Data Converters	dataconverter.ti.com
DLP® Products	www.dlp.com
DSP	dsp.ti.com
Clocks and Timers	www.ti.com/clocks
Interface	interface.ti.com
Logic	logic.ti.com
Power Mgmt	power.ti.com
Microcontrollers	microcontroller.ti.com
RFID	www.ti-rfid.com
OMAP Mobile Processors	www.ti.com/omap
Wireless Connectivity	www.ti.com/wirelessconnectivity

Applications

Communications and Telecom	www.ti.com/communications
Computers and Peripherals	www.ti.com/computers
Consumer Electronics	www.ti.com/consumer-apps
Energy and Lighting	www.ti.com/energy
Industrial	www.ti.com/industrial
Medical	www.ti.com/medical
Security	www.ti.com/security
Space, Avionics and Defense	www.ti.com/space-avionics-defense
Transportation and Automotive	www.ti.com/automotive
Video and Imaging	www.ti.com/video

TI E2E Community Home Page

e2e.ti.com

Mailing Address: Texas Instruments, Post Office Box 655303, Dallas, Texas 75265
Copyright © 2011, Texas Instruments Incorporated