

Dielectric Filters (GIGAFIL[®])



muRata *Innovator
in Electronics*

Murata
Manufacturing Co., Ltd.

CONTENTS

GIGAFIL® in this catalog is the trademark of Murata Manufacturing Co., Ltd.

Part Numbering	2
1 Band Pass Filters	3
DFCB Series 800/900MHz	3
DFCB Series 1.5-5GHz	5
DFCH Series 800/900MHz	8
DFCH Series 1.5-2.5GHz	10
2 Duplexers	12
CDMA800: DFYK Series	12
AMPS/CDMA800: DFYG Series	13
GSM: DFYG Series	15
KPCS: DFYK Series	16
CDMA1.9: DFYK Series	17
W-DCMA: DFYK Series	18
CDMA800: DFYH Series	19
AMPS/CDMA800: DFYH Series	20
EGSM: DFYH Series	21
GSM: DFYHA Series	22
DCS1800: DFYH(A) Series	23
PCS1.9: DFYH Series	24
W-DCMA: DFYHA Series	25
LMR: DFYH Series	26
MSAT: DFYF Series	27
Notice/Packaging/Soldering and Mounting	28

● Part Numbering

Antenna/Duplexer Dielectric Filters (GIGAFIL®)
for RF/Local Dielectric Band Pass Filters (GIGAFIL®)

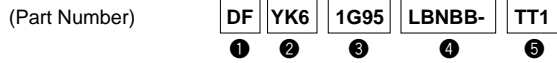

① Product ID

Product ID	
DF	Microwave Filters (GIGAFIL®)

② Series

Two capital letters and a number express the series name.

③ Nominal Center Frequency

Expressed by four-digit alphanumerics. If the unit is "MHz", it is expressed by three figures plus "M". If the unit is "GHz", a decimal point is expressed by capital letter "G".

④ Individual Specification Code

Expressed by five letters plus a hyphen.

⑤ Packaging

Code	Packaging
T**	Tray
R**	Reel

Packaging varies on each product type. Please contact us for details.

Dielectric Filters (GIGAFIL®)



Band Pass Filters

DFCB Series 800/900MHz

■ Features

1. Low insertion loss for using high Q-value dielectric resonators
2. Small and light for using high dielectric constant ceramics
3. Excellent temperature stability for temperature compensated dielectric constant (0+-5 ppm/degree C max.)
4. Excellent mechanical stability without vibratile structure
5. SMD and reflow soldering available
6. Mountable by automatic placement machine

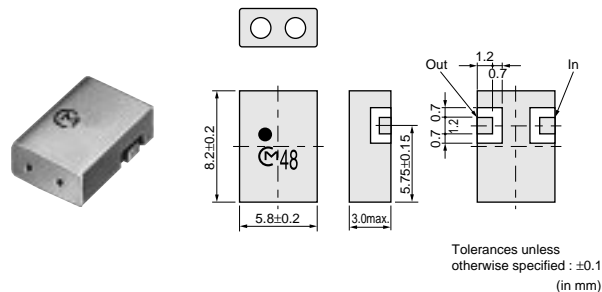

■ Characteristics

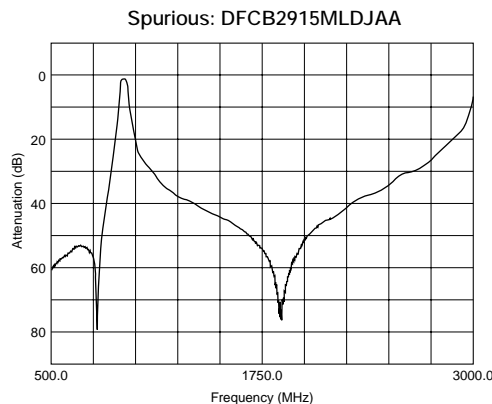
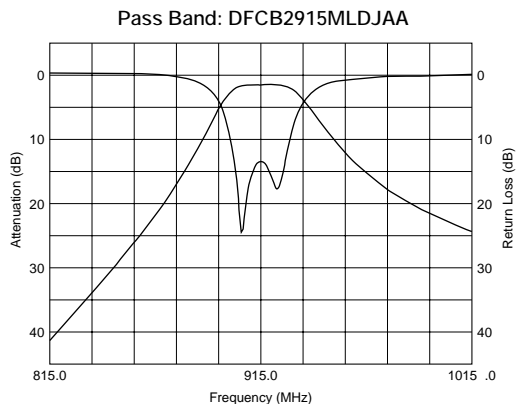

Application	Part Number	fo (MHz)	Bandwidth (MHz)	IL at BW (dB max.)	Attenuation (dB min.)	Operation Temp. (°C)
AMPS	DFCB2836MLDJAA	836.5	25	2.6	6.5 (869 to 894MHz)	-30 to +85
CT2	DFCB2841MLEJAA	841	4	3.0	38 (Fo-150MHz)	-30 to +85
CT2	DFCB2866MLEJAA	866	4	3.0	38 (Fo-150MHz)	-30 to +85
AMPS	DFCB2881MLDJAA	881.5	25	2.6	9 (824 to 849MHz)	-30 to +85
CT1+	DFCB2886MLEJAA	886	2	3.0	24 (Fo-44MHz)	-30 to +85
GSM	DFCB2902MLDJAA	902.5	25	2.6	27 (Fo-77.5MHz)	-30 to +85
WLAN915	DFCB2903MLEJAA	903	2	3.0	20 (Fo+22MHz)	-30 to +85
CT2	DFCB2912MLDJAA	912	4	2.0	50 (Fo-150MHz)	-30 to +85
CT2	DFCB2912MLEJAA	912	4	3.0	38 (Fo-150MHz)	-30 to +85
CT1	DFCB2914MLEJAA	914.5	1	3.0	24 (Fo-44MHz)	-30 to +85
WLAN915	DFCB2915MLDJAA	915	26	2.5	27 (837.5MHz)	-35 to +85
WLAN915	DFCB2926MLEJAA	926.25	2.7	2.8	21 (902.4 to 905.1MHz)	-30 to +85
WLAN915	DFCB2927MLEJAA	927	2	3.0	15 (Fo-22MHz)	-30 to +85
CT1+	DFCB2931MLEJAA	931	2	3.0	24 (Fo-44MHz)	-30 to +85
GSM	DFCB2947MLDJAA	947.5	25	2.6	27 (Fo-77.5MHz)	-30 to +85
CT1	DFCB2959MLEJAA	959.5	1	3.0	30 (Fo+44MHz)	-30 to +85
LMR	DFCB3815MLDJAA	815.5	19	2.5	12 (Fo±35.5MHz)	-30 to +85
AMPS	DFCB3836MLDJAA	836.5	25	3.0	12 (869 to 894MHz)	-30 to +85
CT2	DFCB3841MLEJAA	841	4	5.3	60 (Fo-150MHz)	-30 to +85
LMR	DFCB3860MLDJAA	860.5	19	2.5	13 (Fo-35.5MHz)	-30 to +85

Continued on the following page.

Continued from the preceding page.

Application	Part Number	fo (MHz)	Bandwidth (MHz)	IL at BW (dB max.)	Attenuation (dB min.)	Operation Temp. (°C)
CT2	DFCB3866MLEJAA	866	4	5.3	60 (Fo-150MHz)	-30 to +85
AMPS	DFCB3881MLDJAA	881.5	25	3.0	15 (824 to 849MHz)	-30 to +85
CT1+	DFCB3886MLEJAA	886	2	5.3	45 (Fo-44MHz)	-30 to +85
GSM	DFCB3902MLDJAA	902.5	25	3.0	45 (Fo-77.5MHz)	-30 to +85
WLAN915	DFCB3903MLEJAA	903	2	5.3	29 (Fo-22MHz)	-30 to +85
CT2	DFCB3912MLEJAA	912	4	5.3	60 (Fo-150MHz)	-30 to +85
CT1	DFCB3914MLEJAA	914.5	1	5.3	45 (Fo-44MHz)	-30 to +85
WLAN915	DFCB3915MLDJAA	915	26	3.0	15 (Fo-32.5MHz)	-30 to +85
WLAN915	DFCB3927MLEJAA	927	2	5.3	29 (Fo-22MHz)	-30 to +85
CT1+	DFCB3931MLEJAA	931	2	5.3	45 (Fo-44MHz)	-30 to +85
GSM	DFCB3947MLDJAA	947.5	25	3.0	45 (Fo-77.5MHz)	-30 to +85
CT1	DFCB3959MLEJAA	959.5	1	5.3	45 (Fo-44MHz)	-30 to +85

DFCB Series 1.5-5GHz

■ Features

1. Low insertion loss for using high Q-value dielectric resonators
2. Small and light for using high dielectric constant ceramics
3. Excellent temperature stability for temperature compensated dielectric constant (0+5 ppm/degree C max.)
4. Excellent mechanical stability without vibratile structure
5. SMD and reflow soldering available
6. Mountable by automatic placement machine



DFCB22G33LBJAA

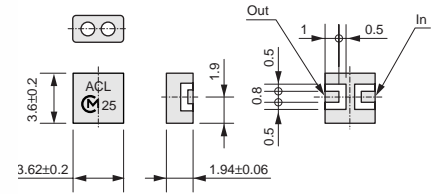

Tolerances unless otherwise specified : ±0.1 (in mm)



DFCB32G33LBJAA

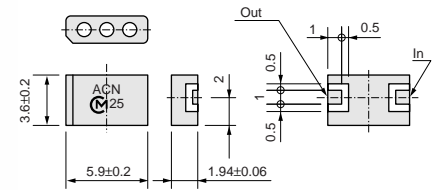

Tolerances unless otherwise specified : ±0.1 (in mm)



DFCB25G25LAHAA

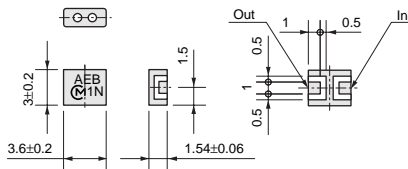

Tolerances unless otherwise specified : ±0.1 (in mm)



DFCB35G25LAHAA

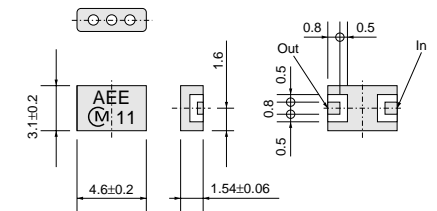

Tolerances unless otherwise specified : ±0.1 (in mm)

■ Characteristics

Pass Band: DFCB22G33LBJAA

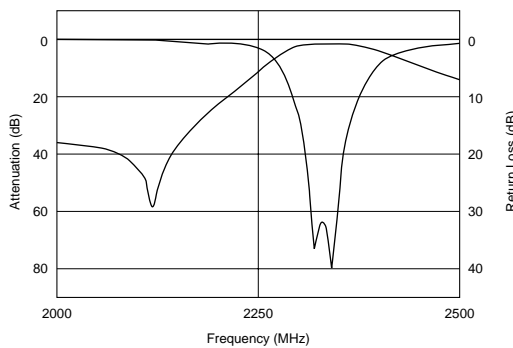

Spurious: DFCB22G33LBJAA

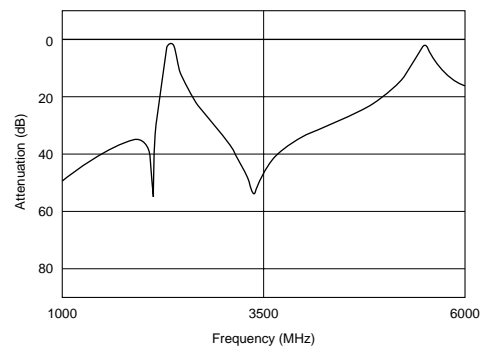

Continued on the following page. ↗

Continued from the preceding page.

Characteristics

Pass Band: DFCB32G33LBJAA

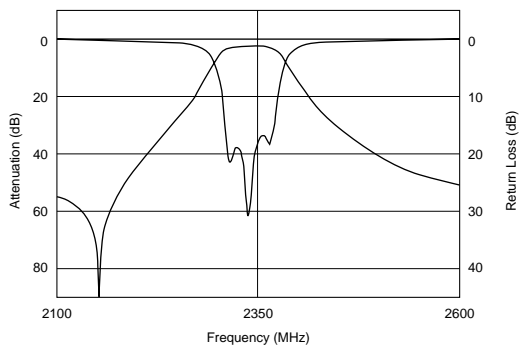

Spurious: DFCB32G33LBJAA

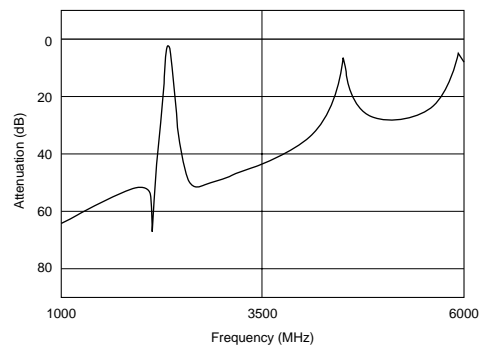

Pass Band: DFCB25G25LAHAA

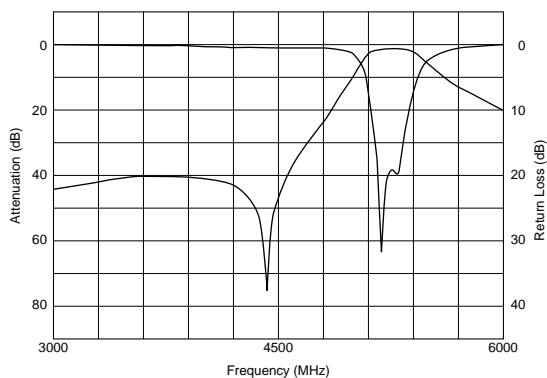

Spurious: DFCB25G25LAHAA

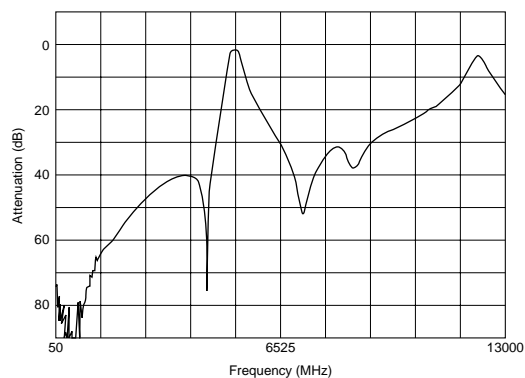

Pass Band: DFCB35G25LAHAA

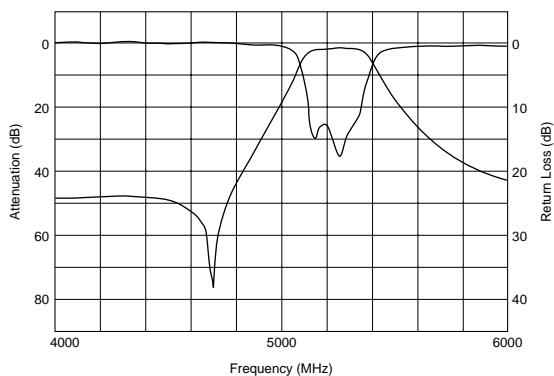

Spurious: DFCB35G25LAHAA

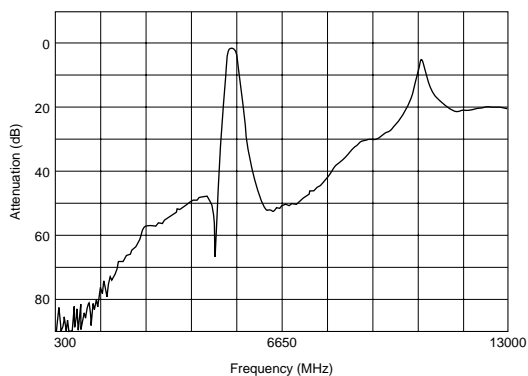

Application	Part Number	fo (MHz)	Bandwidth (MHz)	IL at BW (dB max.)	Attenuation (dB min.)	Operation Temp. (°C)
DAB	DFCB21G47LBJAA	1472	40	2.0	38 (1122MHz)	-30 to +85
PDC1.5	DFCB21G48LBJAA	1489	24	1.4	10 (1607 to 1631MHz)	-30 to +85
GPS	DFCB21G57LBJAB	1575.42	3	1.3	37 (1850 to 1910MHz)	-35 to +85
GPS	DFCB21G57LCJAA	1575.42	2	3.5	15 (Fo±50MHz)	-30 to +85
GPS	DFCB21G57LDJAB	1575.42	2	3.15	18 (Fo±50MHz)	-30 to +85
DCS1800	DFCB21G84LDJAA	1842.5	75	2.0	20 (Fo-160MHz)	-35 to +85
PCS1.9	DFCB21G88LDJAA	1880	60	1.5	17 (2280MHz)	-30 to +85
DECT	DFCB21G89LBJAA	1890	20	2.0	40 (1660 to 1680MHz)	-30 to +85
DECT	DFCB21G89LBJAB	1890	20	1.7	35 (1660 to 1680MHz)	-30 to +85
DECT	DFCB21G89LDHAA	1890	20	0.9	27 (1655 to 1679MHz)	-10 to +55
DECT	DFCB21G89LDJAA	1890	20	2.0	45 (1660 to 1680MHz)	-30 to +85
PHS	DFCB21G90LBJAA	1907.5	25	1.0	20 (1655 to 1680MHz)	-15 to +55

Continued on the following page. ↗

Continued from the preceding page.

Application	Part Number	fo (MHz)	Bandwidth (MHz)	IL at BW (dB max.)	Attenuation (dB min.)	Operation Temp. (°C)
PHS	DFCB21G90LBJAB	1907.5	25	1.6	35 (1655 to 1680MHz)	-15 to +55
PHS	DFCB21G90LBJAC	1907.5	25	1.9	45 (1655 to 1680MHz)	-15 to +55
DECT (CHINA)	DFCB21G91LBJAA	1910	20	1.7	34 (1675 to 1700MHz)	-30 to +85
DECT (CHINA)	DFCB21G91LDJAA	1910	20	1.8	40 (1675 to 1700MHz)	-30 to +85
CDMA1.9	DFCB21G92LBJAA	1920	20	1.2	20 (1655 to 1694MHz)	-30 to +85
CDMA1.9	DFCB21G92LDJAA	1920	20	1.9	16 (1800 to 1820MHz)	-30 to +85
PCS1.9	DFCB21G96LDJAA	1960	60	1.5	17 (2360MHz)	-30 to +85
TD-SCDMA	DFCB22G01LBJAA	2017.5	15	1.5	35 (1270MHz)	-35 to +85
W-CDMA	DFCB22G14LBJAA	2140	60	2.7	26 (1920 to 1980MHz)	-30 to +85
Sirius Radio	DFCB22G32LBJAA	2326	14	1.8	8.5 (2227MHz)	-35 to +85
XM Satellite	DFCB22G33LBJAA	2339	14	1.8	8.5 (2240MHz)	-35 to +85
WLAN2.4	DFCB22G44LANAA	2441.5	83	1.5	35 (2000MHz)	-35 to +85
WLAN2.4	DFCB22G44LBJAA	2442	84	2.0	16 (Fo-250MHz)	-30 to +85
WLAN2.4	DFCB22G45LBJAA	2450	100	2.0	15 (Fo-250MHz)	-30 to +85
WLAN2.4	DFCB22G48LBJAA	2484	26	2.0	27.5 (Fo-204MHz)	-30 to +85
VICS	DFCB22G50LBJAA	2500	4	4.5	20 (2440MHz)	-30 to +85
WLAN5G	DFCB25G25LAHAA	5250	200	1.5	38 (4370 to 4510MHz)	-35 to +85
WLAN5G	DFCB25G59LAHAA	5597.5	255	1.5	11 (Fo-375MHz)	-35 to +85
WLAN5G	DFCB25G77LAHAA	5775	100	1.5	12 (Fo-375MHz)	-35 to +85
ETC	DFCB25G80LBHAA	5800	100	2.0	25 (Fo-375MHz)	-30 to +85
DAB	DFCB31G47LBJAA	1472	40	3.0	45 (1100MHz)	-35 to +85
DCS1800	DFCB31G74LBJAA	1747.5	75	3.5	45 (1464 to 1539MHz)	-30 to +85
DCS1800	DFCB31G84LBJAA	1842.5	75	3.5	45 (1559 to 1634MHz)	-30 to +85
DCS1800	DFCB31G84LBJAB	1842.5	75	2.75	45 (0.3 to 1388MHz)	-30 to +85
PCS1.9	DFCB31G88LBJAA	1880	60	3.7	5 (1930MHz)	-30 to +85
PCS1.9	DFCB31G88LBJAB	1880	60	4.0	41 (2043 to 2103MHz)	-30 to +85
W-CDMA	DFCB31G95LBJAA	1950	60	3.5	35 (2110 to 2170MHz)	-30 to +85
PCS1.9	DFCB31G96LBJAA	1960	60	3.7	5 (1910MHz)	-30 to +85
PCS1.9	DFCB31G96LBJAB	1960	60	3.0	10 (1498 to 1860MHz)	-30 to +85
PCS1.9	DFCB31G96LBJAC	1960	60	2.8	10 (1860MHz)	-30 to +85
PCS1.9	DFCB31G96LBJAE	1960	60	3.7	20 (2065 to 2125MHz)	-35 to +85
W-CDMA	DFCB32G14LBJAA	2140	60	3.7	30 (1920 to 1980MHz)	-30 to +85
Sirius Radio	DFCB32G32LBJAA	2326	14	3.0	24 (2227MHz)	-35 to +85
XM Satellite	DFCB32G33LBJAA	2339	14	3.0	24 (2240MHz)	-35 to +85
WLAN2.4	DFCB32G44LBJAA	2442	84	3.2	30 (Fo-250MHz)	-30 to +85
WLAN2.4	DFCB32G45LBJAA	2450	100	3.2	30 (Fo-250MHz)	-30 to +85
WLAN5G	DFCB35G25LAHAA	5250	200	3.3	45 (4450 to 4650MHz)	-35 to +85
WLAN5G	DFCB35G59LAHAA	5597.5	255	3.6	45 (4750 to 5000MHz)	-35 to +85
WLAN5G	DFCB35G77LAHAA	5775	100	3.0	30 (Fo-375MHz)	-35 to +85
WLAN5G	DFCB35G80LBHAA	5800	150	3.4	10 (Fo-175MHz)	-35 to +85

DFCH Series 800/900MHz

■ Features

1. Low insertion loss for using high Q-value dielectric resonators
2. Small and light for using high dielectric constant ceramics
3. Excellent temperature stability for temperature compensated dielectric constant (0+5 ppm/degree C max.)
4. Excellent mechanical stability without vibratile structure
5. SMD and reflow soldering available
6. Mountable by automatic placement machine

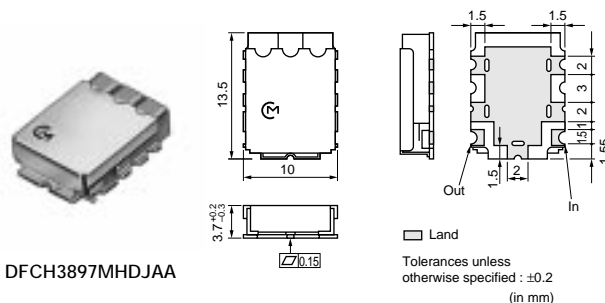

DFCH3897MHDJAA

Land
Tolerances unless otherwise specified : ±0.2 (in mm)

■ Characteristics

Pass Band: DFCH3897MHDJAA

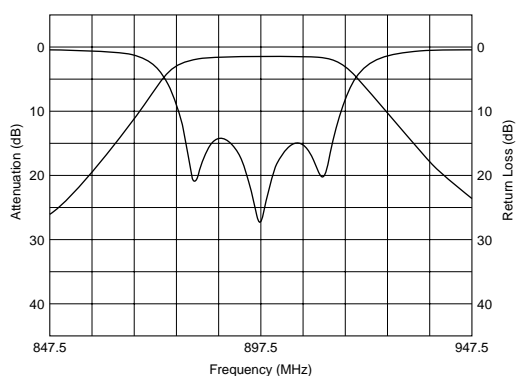

Spurious: DFCH3897MHDJAA

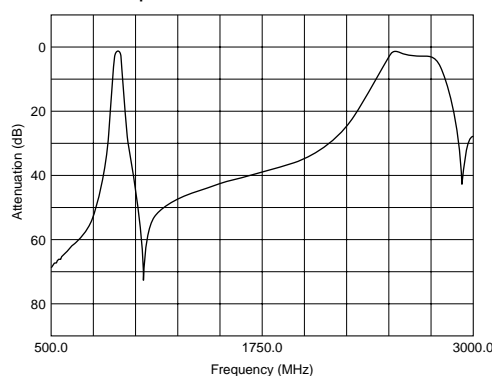

Pass Band: DFCH3942MHDJAA

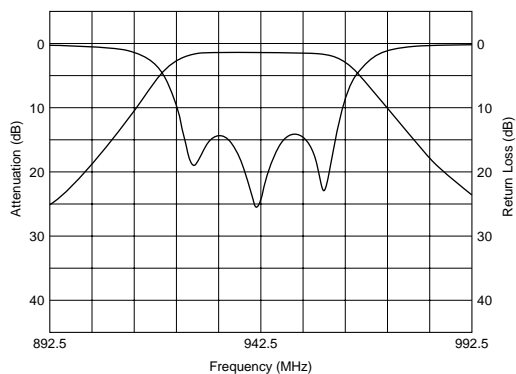

Spurious: DFCH3942MHDJAA

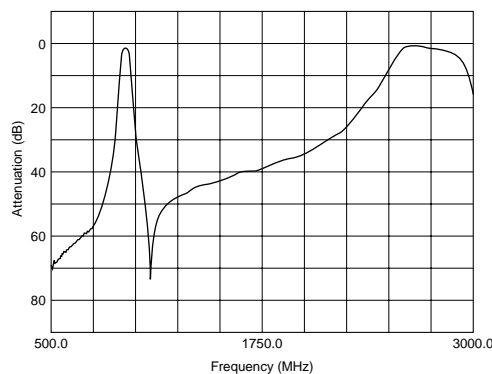

Application	Part Number	fo (MHz)	Bandwidth (MHz)	IL at BW (dB max.)	Attenuation (dB min.)	Operation Temp. (°C)
LMR	DFCH3815MHDJAA	815	20	2.8	36 (Fo±80MHz)	-30 to +85
AMPS	DFCH3836MHDJAA	836.5	25	2.6	12 (Fo±32.5MHz)	-30 to +85
LMR	DFCH3860MHDJAA	860	20	2.8	36 (Fo±80MHz)	-30 to +85
AMPS	DFCH3881MHDJAA	881.5	25	2.6	12 (Fo±32.5MHz)	-30 to +85
ETACS	DFCH3888MHDJAA	888.5	33	3.0	7 (Fo±28.5MHz)	-30 to +85
EGSM	DFCH3897MHDJAA	897.5	35	3.0	6 (Fo±27.5MHz)	-30 to +85
GSM	DFCH3902MHDJAA	902.5	25	2.6	12 (Fo±32.5MHz)	-30 to +85
ETACS	DFCH3933MHDJAA	933.5	33	3.0	7 (Fo±28.5MHz)	-30 to +85
EGSM	DFCH3942MHDJAA	942.5	35	3.0	6 (Fo±27.5MHz)	-30 to +85
GSM	DFCH3947MHDJAA	947.5	25	2.6	12 (Fo±32.5MHz)	-30 to +85
ETACS	DFCH4888MHDJAA	888.5	33	4.6	15 (Fo±28.5MHz)	-30 to +85

Continued on the following page. ↗

Continued from the preceding page.

Application	Part Number	fo (MHz)	Bandwidth (MHz)	IL at BW (dB max.)	Attenuation (dB min.)	Operation Temp. (°C)
EGSM	DFCH4897MHDJAA	897.5	35	4.6	13 (Fo±27.5MHz)	-30 to +85
ETACS	DFCH4933MHDJAA	933.5	33	4.6	15 (Fo±28.5MHz)	-30 to +85
EGSM	DFCH4942MHDJAA	942.5	35	4.6	13 (Fo±27.5MHz)	-30 to +85

DFCH Series 1.5-2.5GHz

■ Features

1. Low insertion loss for using high Q-value dielectric resonators
2. Small and light for using high dielectric constant ceramics
3. Excellent temperature stability for temperature compensated dielectric constant (0+5 ppm/degree C max.)
4. Excellent mechanical stability without vibratile structure
5. SMD and reflow soldering available
6. Mountable by automatic placement machine

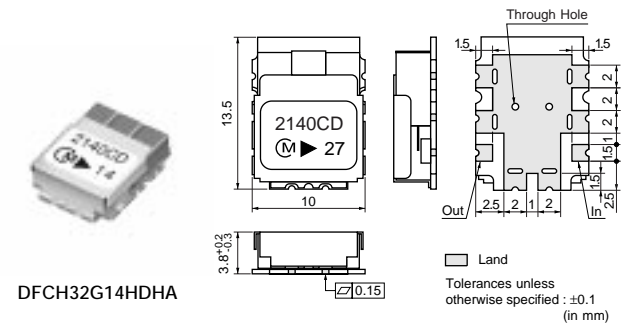
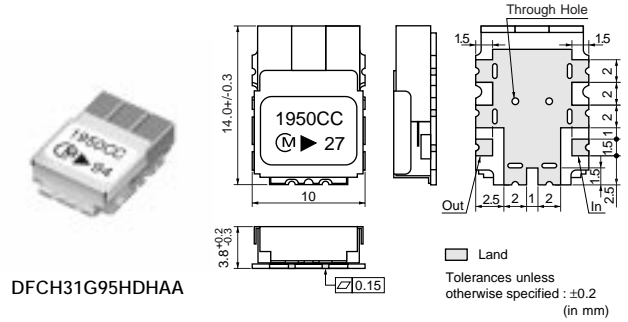

■ Characteristics

Pass Band: DFCH31G95HDHAA

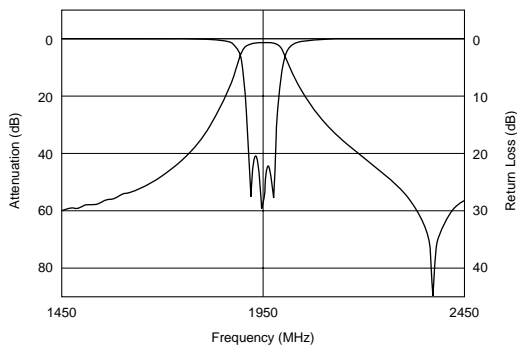

Spurious: DFCH31G95HDHAA

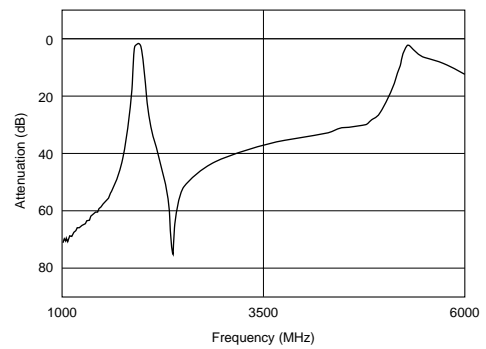

Pass Band: DFCH32G14HDHA

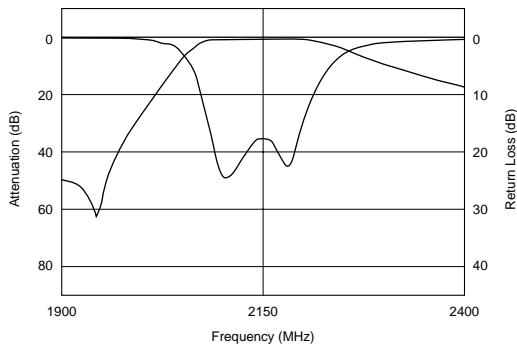

Spurious: DFCH32G14HDHA

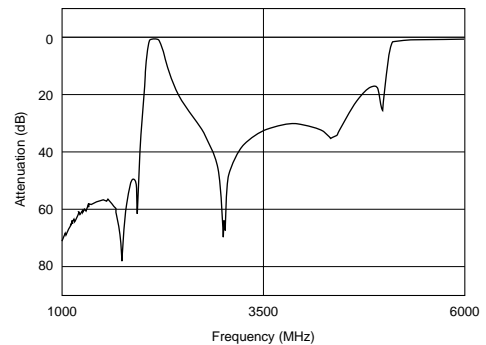

Application	Part Number	fo (MHz)	Bandwidth (MHz)	IL at BW (dB max.)	Attenuation (dB min.)	Operation Temp. (°C)
GPS	DFCH21G57HDHAA	1575.5	2	0.9	16 (Fo-140MHz)	-30 to +85
PHS	DFCH21G90HDJAA	1907.5	25	0.7	35 (Fo-227.5MHz)	-30 to +85
WLAN2.4	DFCH22G44HDHAA	2442	84	1.2	15 (Fo±250MHz)	-30 to +85
WLAN2.4	DFCH22G45HDHAA	2450	100	1.0	16 (Fo-250MHz)	-30 to +85
WLAN2.4	DFCH22G48HDHAA	2484	26	2.5	47 (Fo-270MHz)	-30 to +85
VICS	DFCH22G50HDHAA	2500	4	2.4	10 (Fo±60MHz)	-30 to +85
MSAT	DFCH31G54HDJAA	1542	34	3.0	30 (1626.5 to 1660.5MHz)	-30 to +85
MSAT	DFCH31G64HDJAA	1643.5	34	3.0	30 (1525 to 1559MHz)	-30 to +85
DCS1800	DFCH31G74HDJAA	1747.5	75	2.0	8 (Fo±80MHz)	-30 to +85
DCS1800	DFCH31G84HDJAA	1842.5	75	2.0	8 (Fo±80MHz)	-30 to +85
PCS1.9	DFCH31G88HDJAA	1880	60	2.2	15 (Fo±100MHz)	-30 to +85
W-CDMA	DFCH31G95HDHAA	1950	60	1.8	45 (1550MHz)	-30 to +85
PCS1.9	DFCH31G96HDJAA	1960	60	2.2	15 (Fo±100MHz)	-30 to +85
W-CDMA	DFCH32G14HDHAA	2140	60	1.3	52 (1325 to 1385MHz)	-30 to +85
MMDS	DFCH32G15HDHAB	2156	20	3.0	36 (2050MHz)	-35 to +85
WLAN2.4	DFCH32G44HDHAA	2442	84	2.4	36 (Fo-250MHz)	-30 to +85
WLAN2.4	DFCH32G45HDHAA	2450	100	2.3	36 (Fo-250MHz)	-30 to +85
WLAN2.4	DFCH32G48HDHAA	2484	26	3.0	45 (Fo-270MHz)	-30 to +85
DCS1800	DFCH41G74HDJAA	1747.5	75	3.6	10 (Fo±57.5MHz)	-30 to +85
DCS1800	DFCH41G84HDJAA	1842.5	75	3.6	10 (Fo±57.5MHz)	-30 to +85
PCS1.9	DFCH41G88HDJAA	1880	60	4.5	12 (Fo±50MHz)	-30 to +85
PCS1.9	DFCH41G96HDJAA	1960	60	4.5	12 (Fo±50MHz)	-30 to +85
MMDS	DFCH42G59HDHAB	2593	186	1.8	50 (Fo-400MHz)	-35 to +85

Dielectric Filters (GIGAFIL®)



Duplexers

2

CDMA800: DFYK Series

■ Features

1. Low insertion loss for using high Q-value dielectric resonators
2. Small and light for using high dielectric constant ceramics
3. Excellent temperature stability for temperature compensated dielectric constant (0+-5 ppm/degree C max.)
4. Excellent mechanical stability without vibratile structure
5. SMD and reflow soldering available
6. Mountable by automatic placement machine

■ Characteristics

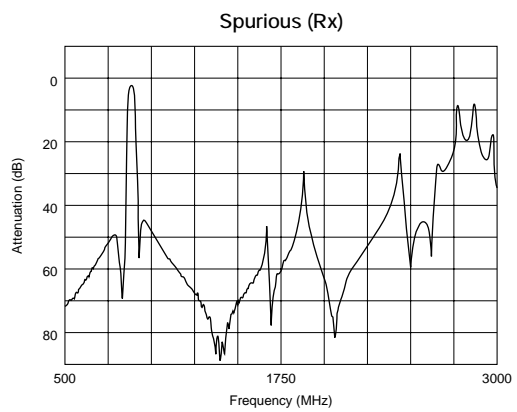
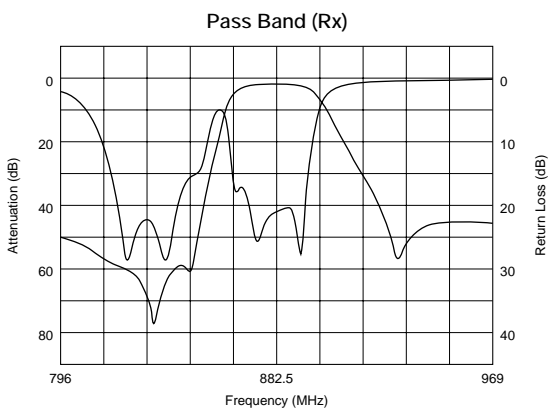
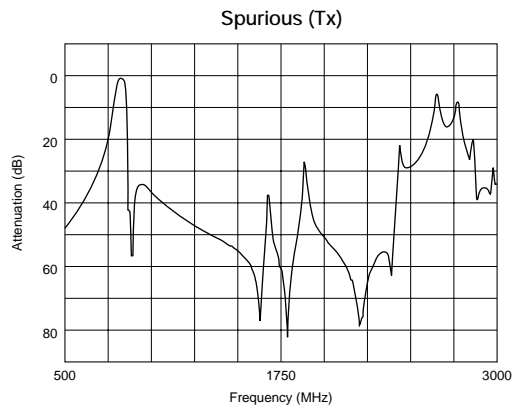
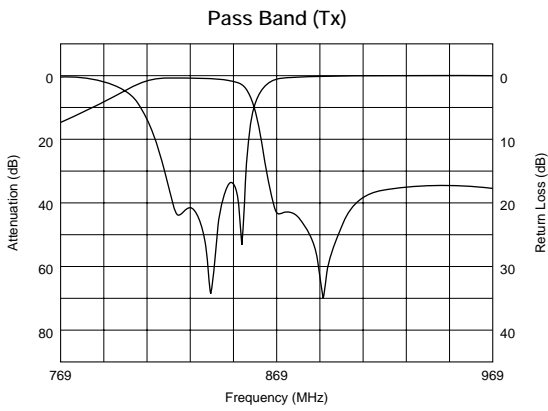
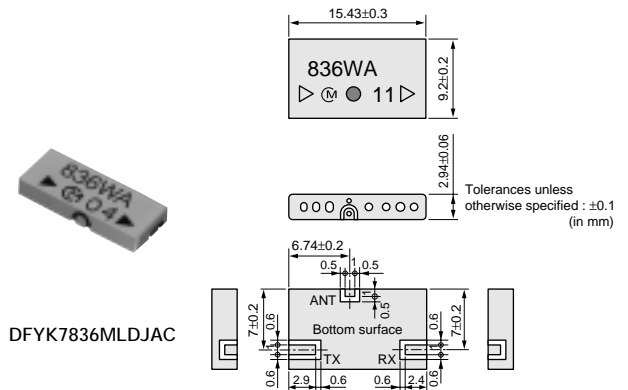

Part Number	fo (Tx) (MHz)	Bandwidth (Tx) (MHz)	IL at BW (dB max.)	Attenuation (dB min.)	fo (Rx) (MHz)	Bandwidth (Rx) (MHz)	IL at BW (dB max.)	Attenuation (dB min.)	Operation Temperature Range (°C)
DFYK7836MLDJAC	836.5	25.0	2.9	38 (869 to 894MHz)	881.5	25.0	4.0	56 (824 to 849MHz)	-35 to +85
DFYK7836MLEJAA	836.5	25.0	2.6	42 (869 to 894MHz) +10 to +35 degree C	881.5	25.0	3.3	56 (824 to 849MHz) +10 to 35 degree C	-35 to +85

AMPS/CDMA800: DFYG Series

■ Features

1. Low insertion loss for using high Q-value dielectric resonators
2. Small and light for using high dielectric constant ceramics
3. Excellent temperature stability for temperature compensated dielectric constant (0+5 ppm/degree C max.)
4. Excellent mechanical stability without vibratile structure
5. SMD and reflow soldering available
6. Mountable by automatic placement machine

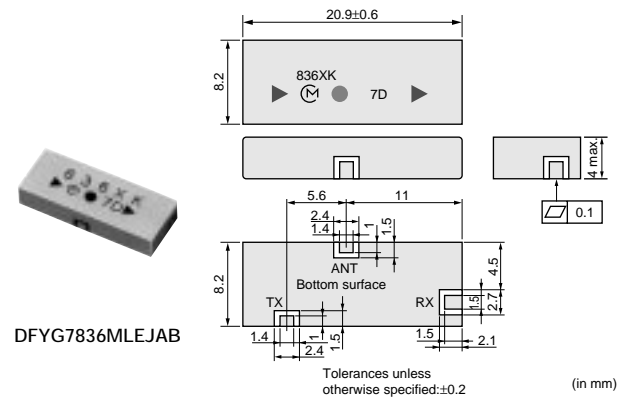
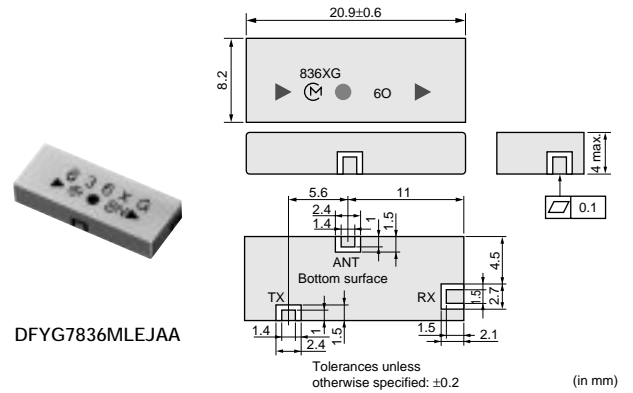

■ Characteristics

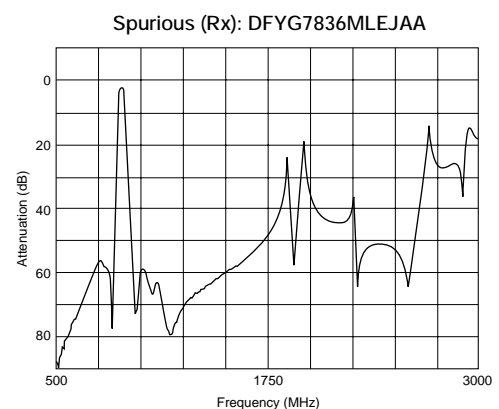
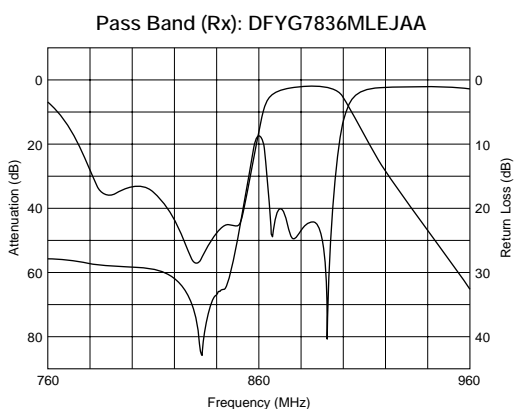
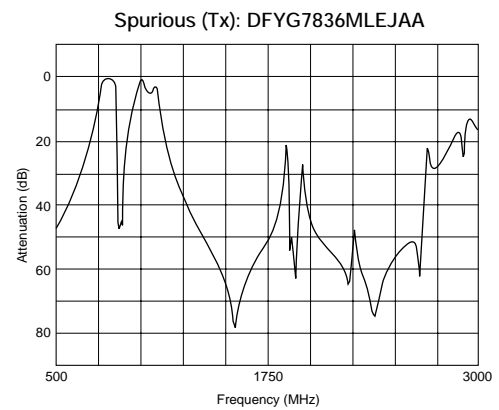
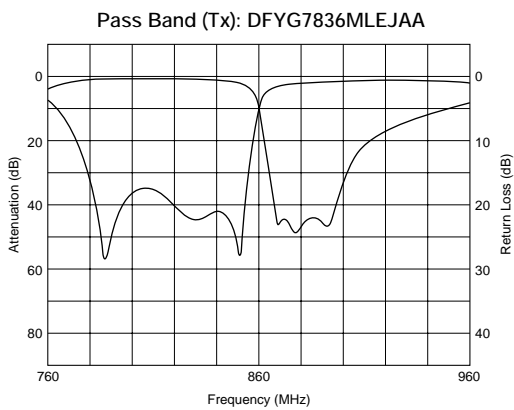

Continued on the following page. ↗

Continued from the preceding page.

Characteristics

Pass Band (Tx) :DFYG7836MLEJAB

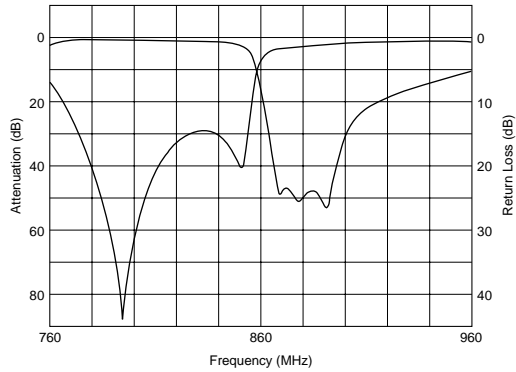

Spurious (Tx) :DFYG7836MLEJAB

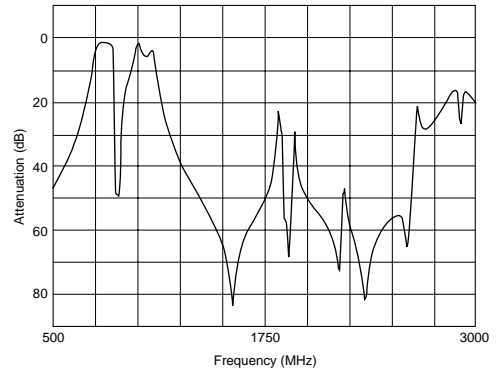

Pass Band (Rx) :DFYG7836MLEJAB

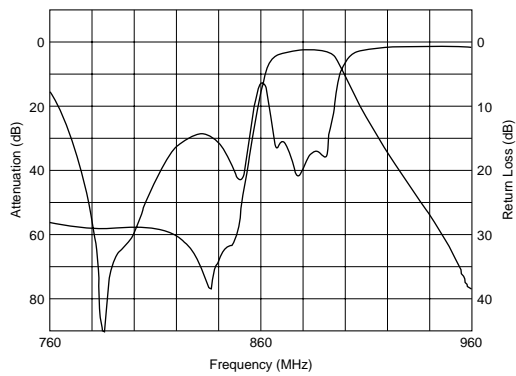

Spurious (Rx) :DFYG7836MLEJAB

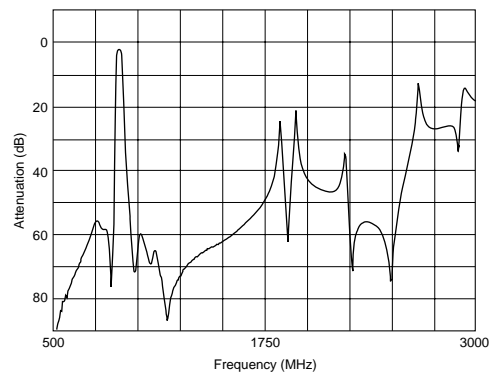

Part Number	fo (Tx) (MHz)	Bandwidth (Tx) (MHz)	IL at BW (dB max.)	Attenuation (dB min.)	fo (Rx) (MHz)	Bandwidth (Rx) (MHz)	IL at BW (dB max.)	Attenuation (dB min.)	Operation Temperature Range (°C)
DFYG7836MLEJAA	836.5	25	2.6	42 (869 to 894MHz)	881.5	25	4.1	50 (824 to 849MHz)	-30 to +85
DFYG7836MLEJAB	836.5	25	2.6	42 (869 to 894MHz)	881.5	25	4.5	56 (824 to 849MHz)	-30 to +85

GSM: DFYG Series

■ Features

1. Low insertion loss for using high Q-value dielectric resonators
2. Small and light for using high dielectric constant ceramics
3. Excellent temperature stability for temperature compensated dielectric constant (0+5 ppm/degree C max.)
4. Excellent mechanical stability without vibratile structure
5. SMD and reflow soldering available
6. Mountable by automatic placement machine

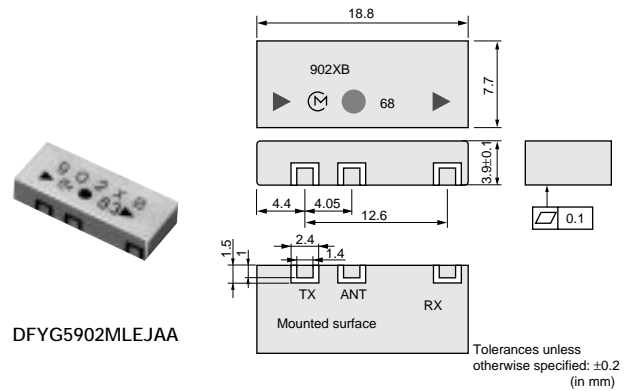

■ Characteristics

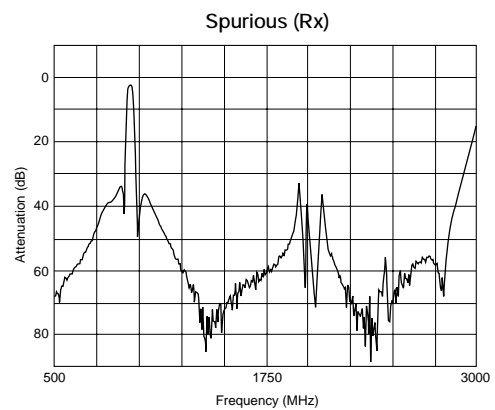
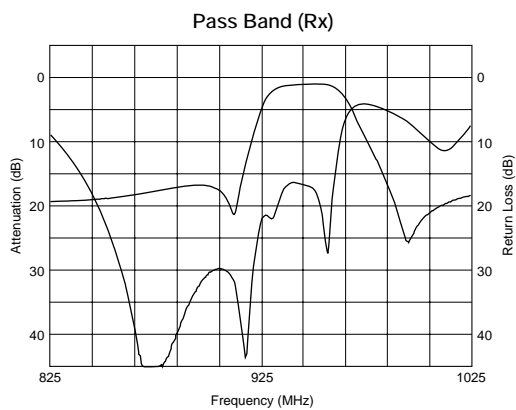
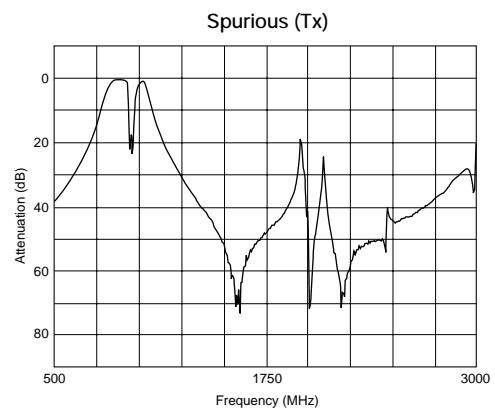
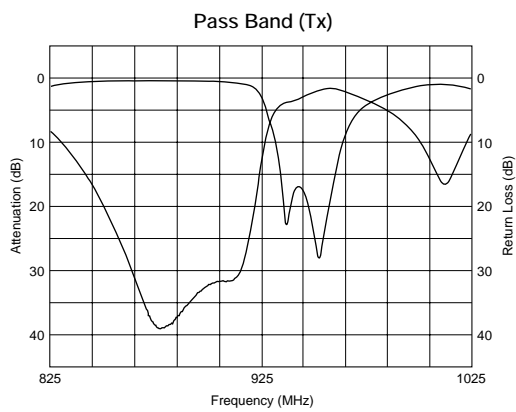

Part Number	fo (Tx) (MHz)	Bandwidth (Tx) (MHz)	IL at BW (dB max.)	Attenuation (dB min.)	fo (Rx) (MHz)	Bandwidth (Rx) (MHz)	IL at BW (dB max.)	Attenuation (dB min.)	Operation Temperature Range (°C)
DFYG5902MLEJAA	902.5	25	1.3	14 (935 to 960MHz)	947.5	25	3.5	29 (890 to 915MHz)	-30 to +85
DFYG5902MLEJAB	902.5	25	1.8	14.5 (935 to 960MHz) -20 to +75 degree C	947.5	25	3.2	30 (890 to 915MHz)	-20 to +75
DFYG6902MLEJAA	902.5	25	2.2	20 (935 to 960MHz)	947.5	25	3.2	30 (890 to 915MHz)	-20 to +75

KPCS: DFYK Series

■ Features

1. Low insertion loss for using high Q-value dielectric resonators
2. Small and light for using high dielectric constant ceramics
3. Excellent temperature stability for temperature compensated dielectric constant (0+5 ppm/degree C max.)
4. Excellent mechanical stability without vibratile structure
5. SMD and reflow soldering available
6. Mountable by automatic placement machine

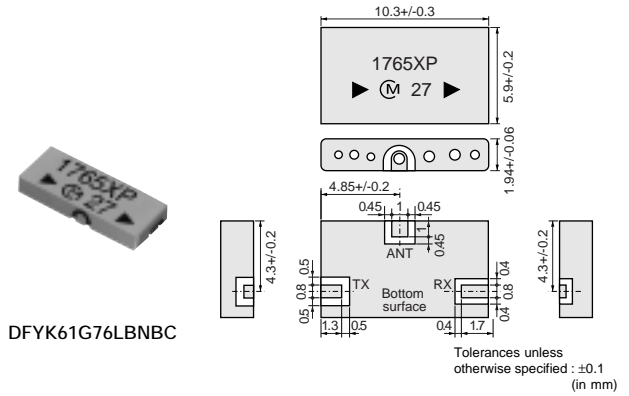

■ Characteristics

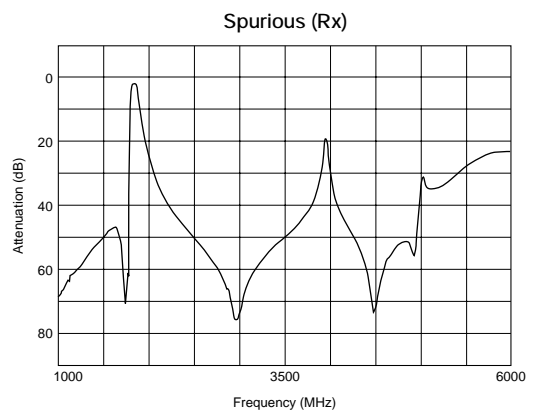
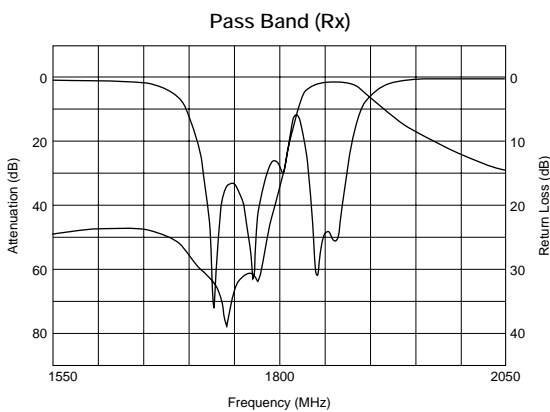
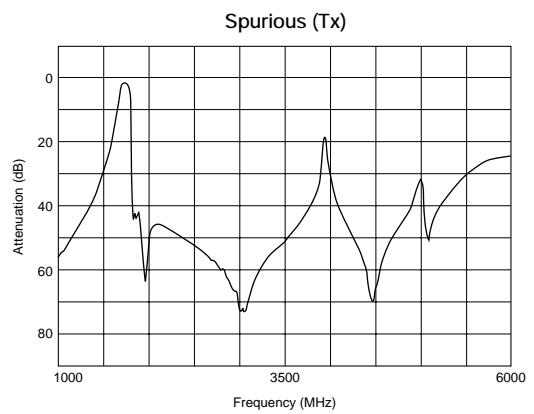
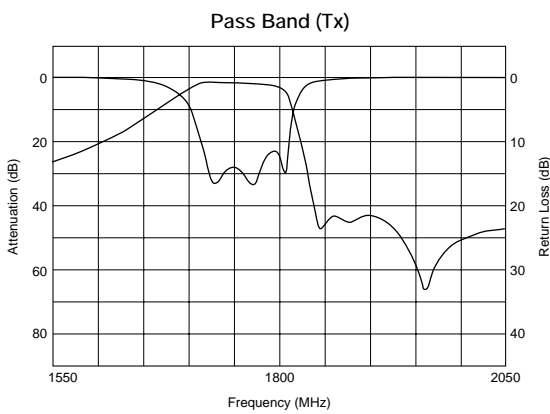

Part Number	fo (Tx) (MHz)	Bandwidth (Tx) (MHz)	IL at BW (dB max.)	Attenuation (dB min.)	fo (Rx) (MHz)	Bandwidth (Rx) (MHz)	IL at BW (dB max.)	Attenuation (dB min.)	Operation Temperature Range (°C)
DFYK61G76LBNBC	1765	30	2.3	38 (1840 to 1870MHz)	1855	30	3.3	57 (1750 to 1780MHz)	-35 to +85

CDMA1.9: DFYK Series

■ Features

1. Low insertion loss for using high Q-value dielectric resonators
2. Small and light for using high dielectric constant ceramics
3. Excellent temperature stability for temperature compensated dielectric constant (0+5 ppm/degree C max.)
4. Excellent mechanical stability without vibratile structure
5. SMD and reflow soldering available
6. Mountable by automatic placement machine

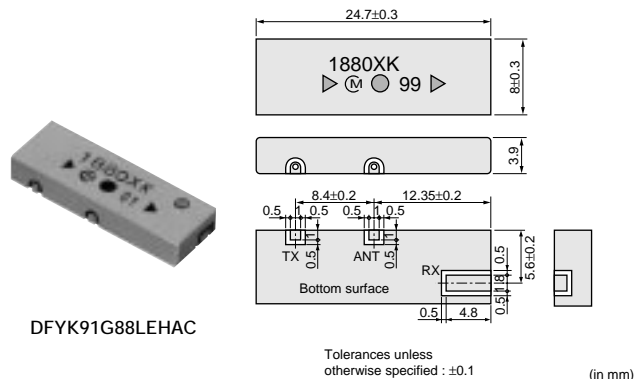

DFYK91G88LEHAC

■ Characteristics

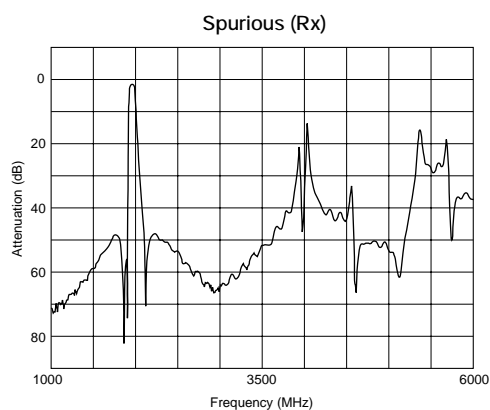
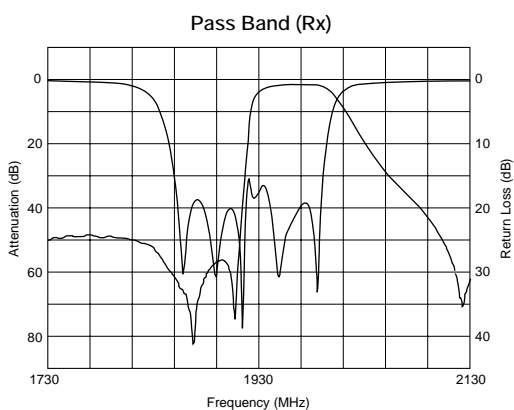
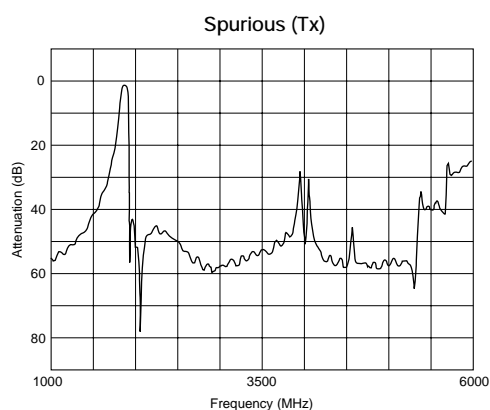
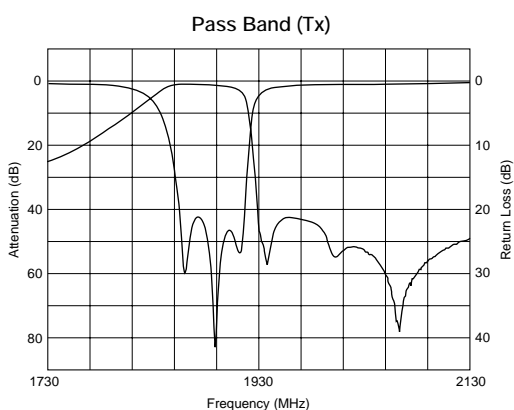

Part Number	fo (Tx) (MHz)	Bandwidth (Tx) (MHz)	IL at BW (dB max.)	Attenuation (dB min.)	fo (Rx) (MHz)	Bandwidth (Rx) (MHz)	IL at BW (dB max.)	Attenuation (dB min.)	Operation Temperature Range (°C)
DFYK91G88LEHAB	1880	60	3.4	40 (1930 to 1990MHz)	1960	60	4.1	50 (1850 to 1910MHz) 0 to +35 degree C	-35 to +85
DFYK91G88LEHAC	1880	60	3.4	40 (1930 to 1990MHz)	1960	60	4.6	53 (1850 to 1910MHz) -35 to +85 degree C	-35 to +85

W-DCMA: DFYK Series

■ Features

1. Low insertion loss for using high Q-value dielectric resonators
2. Small and light for using high dielectric constant ceramics
3. Excellent temperature stability for temperature compensated dielectric constant (0+5 ppm/degree C max.)
4. Excellent mechanical stability without vibratile structure
5. SMD and reflow soldering available
6. Mountable by automatic placement machine



DFYK61G95LBJCA

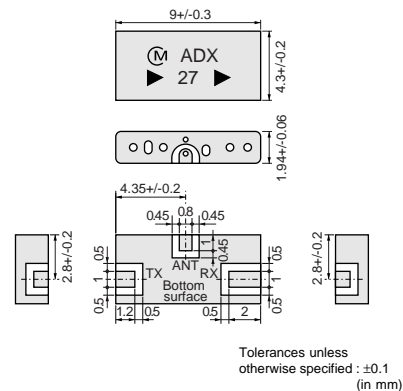

■ Characteristics

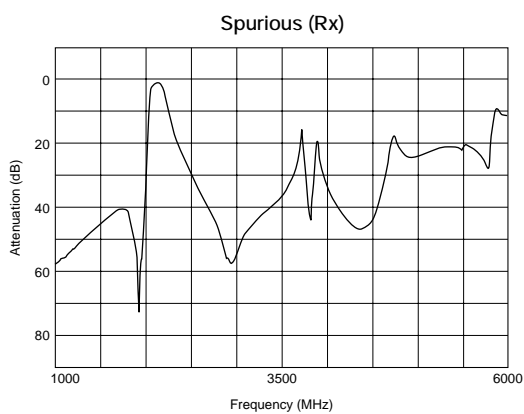
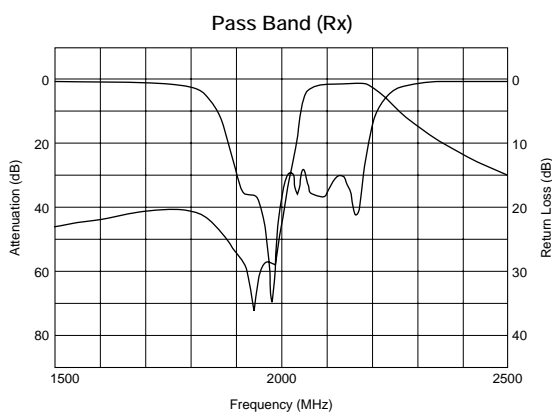
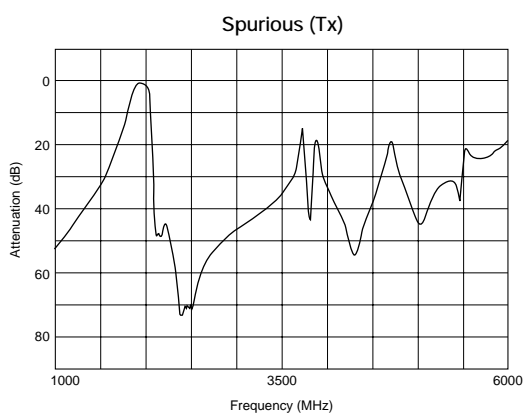
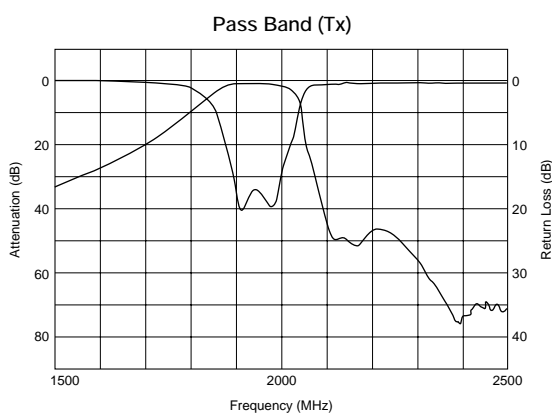

Part Number	fo (Tx) (MHz)	Bandwidth (Tx) (MHz)	IL at BW (dB max.)	Attenuation (dB min.)	fo (Rx) (MHz)	Bandwidth (Rx) (MHz)	IL at BW (dB max.)	Attenuation (dB min.)	Operation Temperature Range (°C)
DFYK61G95LBJCA	1950	60	1.5	44 (2110 to 2170MHz)	2140	60	1.8	54 (1920 to 1980MHz)	-35 to +85
DFYK61G95LBNCB	1950	60	1.4	43 (2110 to 2170MHz)	2140	60	2.2	48 (1920 to 1980MHz)	-35 to +85

CDMA800: DFYH Series

■ Features

1. Low insertion loss for using high Q-value dielectric resonators
2. Small and light for using high dielectric constant ceramics
3. Excellent temperature stability for temperature compensated dielectric constant (0+5 ppm/degree C max.)
4. Excellent mechanical stability without vibratile structure
5. SMD and reflow soldering available
6. Mountable by automatic placement machine

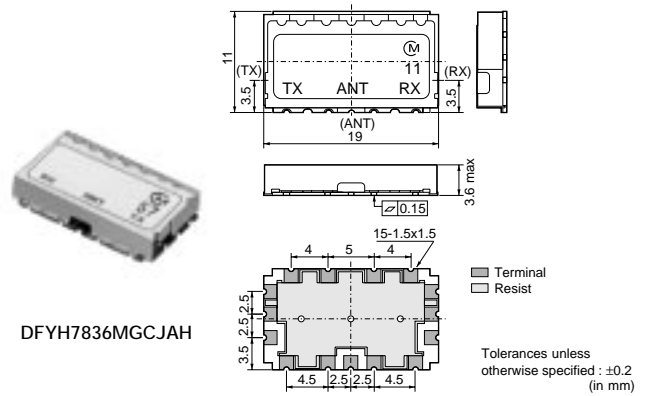

DFYH7836MGCJAH

■ Characteristics

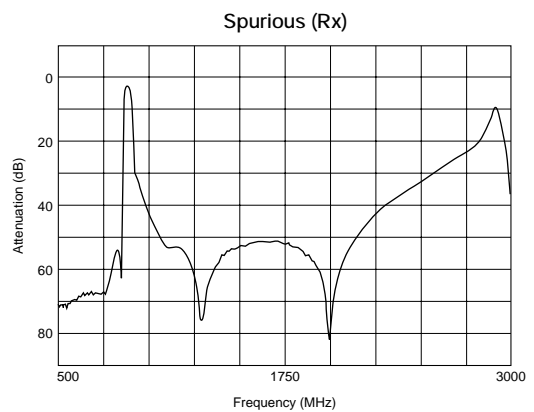
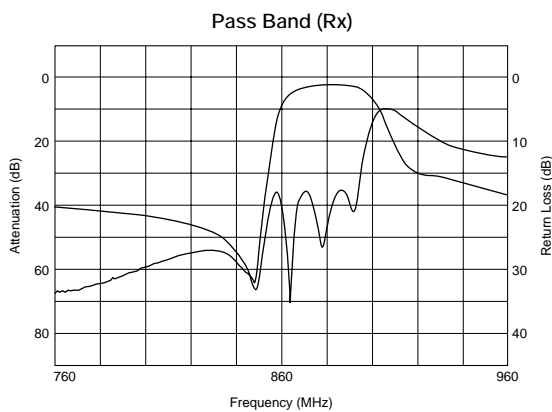
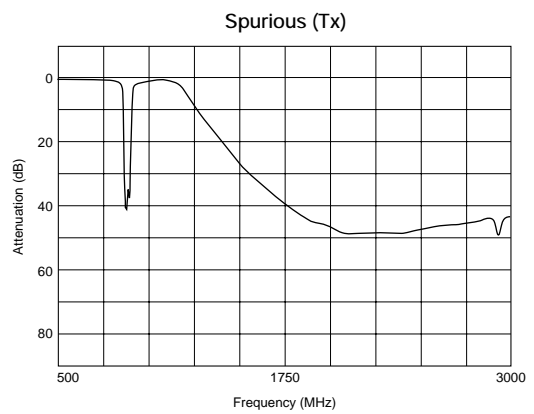
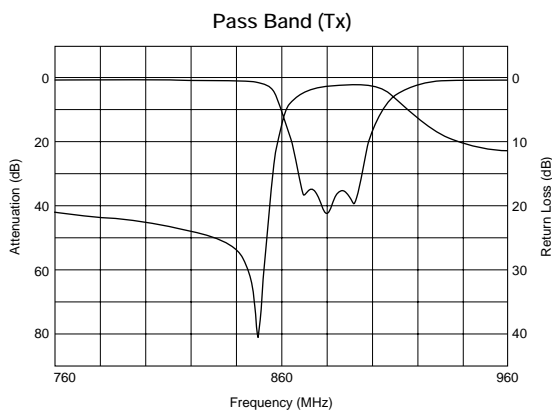

Part Number	fo (Tx) (MHz)	Bandwidth (Tx) (MHz)	IL at BW (dB max.)	Attenuation (dB min.)	fo (Rx) (MHz)	Bandwidth (Rx) (MHz)	IL at BW (dB max.)	Attenuation (dB min.)	Operation Temperature Range (°C)
DFYH7836MGCJAH	836.5	25	2.0	32 (869 to 894MHz)	881.5	25	4.3	50 (824 to 849MHz)	-30 to +85

AMPS/CDMA800: DFYH Series

■ Features

1. Low insertion loss for using high Q-value dielectric resonators
2. Small and light for using high dielectric constant ceramics
3. Excellent temperature stability for temperature compensated dielectric constant (0+5 ppm/degree C max.)
4. Excellent mechanical stability without vibratile structure
5. SMD and reflow soldering available
6. Mountable by automatic placement machine

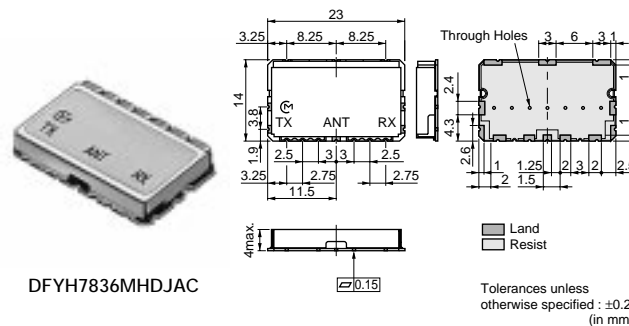

DFYH7836MHDJAC

■ Characteristics

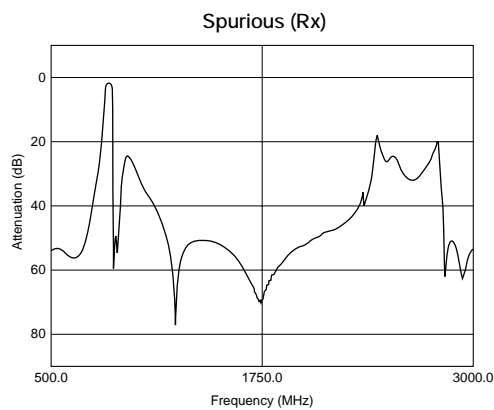
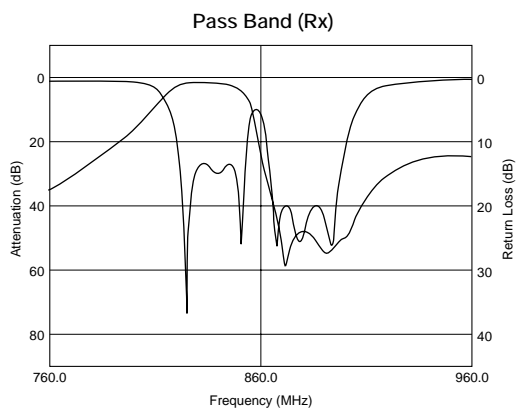
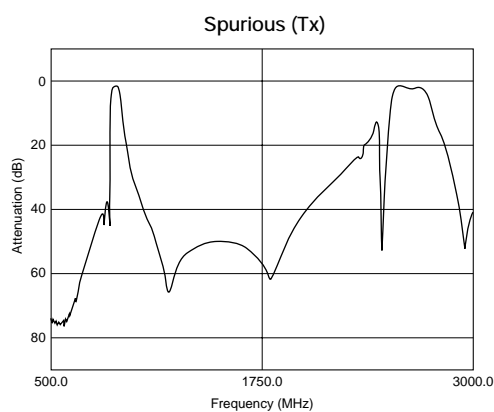
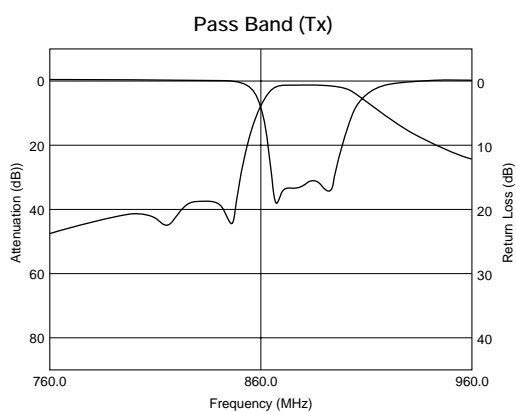

Part Number	fo (Tx) (MHz)	Bandwidth (Tx) (MHz)	IL at BW (dB max.)	Attenuation (dB min.)	fo (Rx) (MHz)	Bandwidth (Rx) (MHz)	IL at BW (dB max.)	Attenuation (dB min.)	Operation Temperature Range (°C)
DFYH7836MHDJAC	881.5	25	3.0	35 (824 to 849MHz)	836.5	25	4.0	45 (869 to 894MHz)	-30 to +85

EGSM: DFYH Series

■ Features

1. Low insertion loss for using high Q-value dielectric resonators
2. Small and light for using high dielectric constant ceramics
3. Excellent temperature stability for temperature compensated dielectric constant (0+5 ppm/degree C max.)
4. Excellent mechanical stability without vibratile structure
5. SMD and reflow soldering available
6. Mountable by automatic placement machine

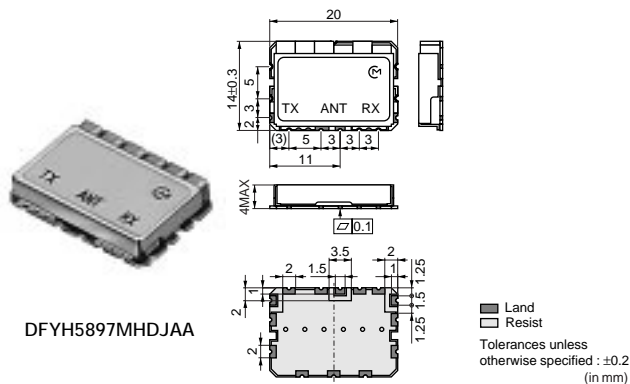

■ Characteristics

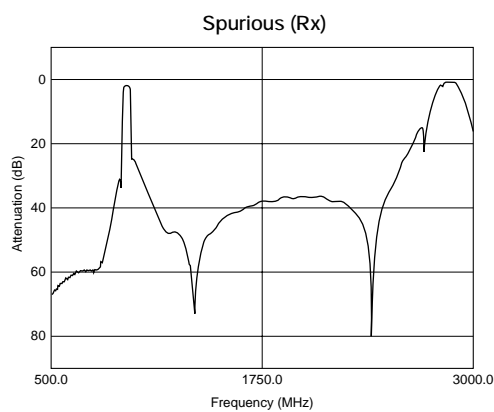
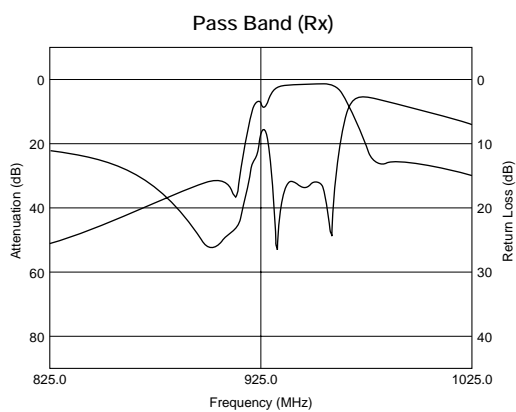
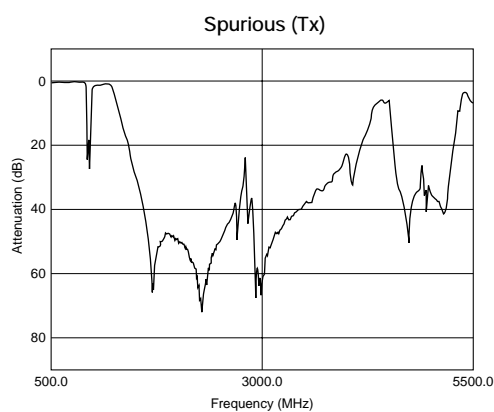
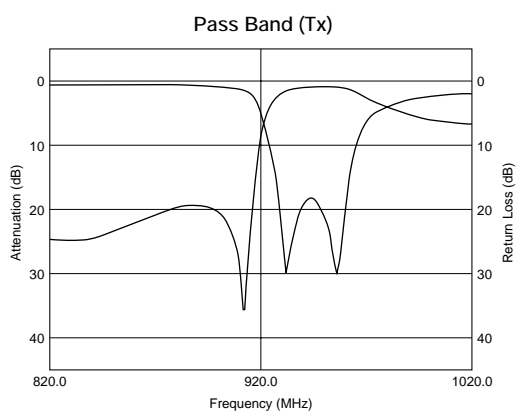

Part Number	fo (Tx) (MHz)	Bandwidth (Tx) (MHz)	IL at BW (dB max.)	Attenuation (dB min.)	fo (Rx) (MHz)	Bandwidth (Rx) (MHz)	IL at BW (dB max.)	Attenuation (dB min.)	Operation Temperature Range (°C)
DFYH5897MHDJAA	897.5	35	2.0	15 (935 to 960MHz)	942.5	35	4.3	20 (905 to 915MHz)	-30 to +85

GSM: DFYHA Series

■ Features

1. Low insertion loss for using high Q-value dielectric resonators
2. Small and light for using high dielectric constant ceramics
3. Excellent temperature stability for temperature compensated dielectric constant (0+5 ppm/degree C max.)
4. Excellent mechanical stability without vibratile structure
5. SMD and reflow soldering available
6. Mountable by automatic placement machine

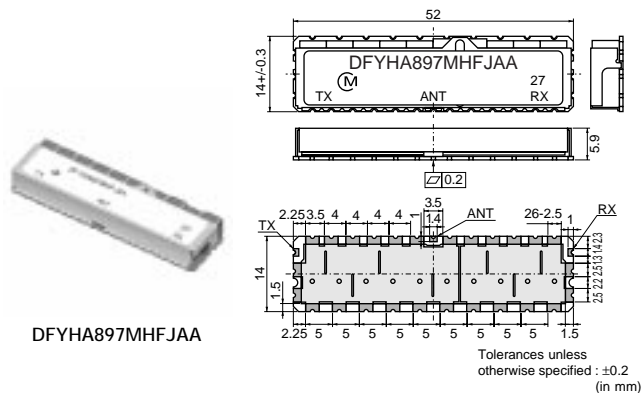

■ Characteristics

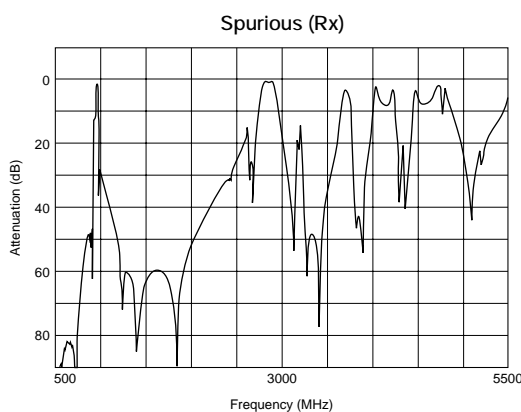
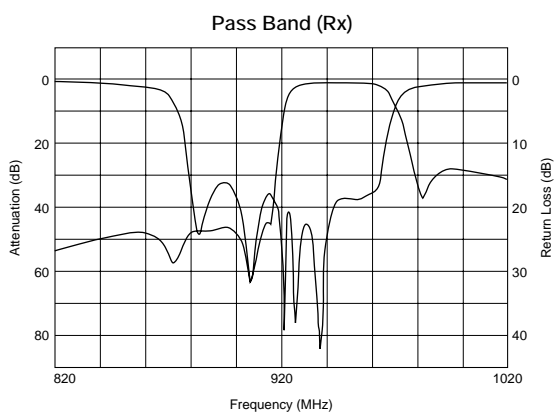
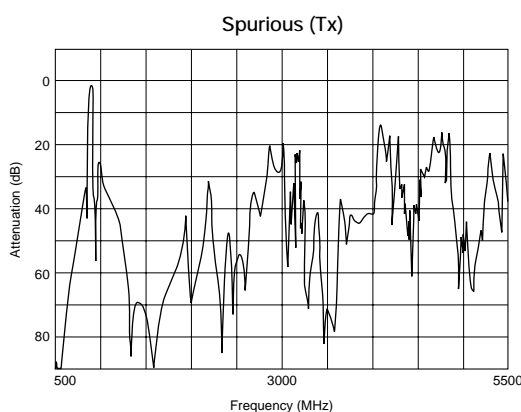
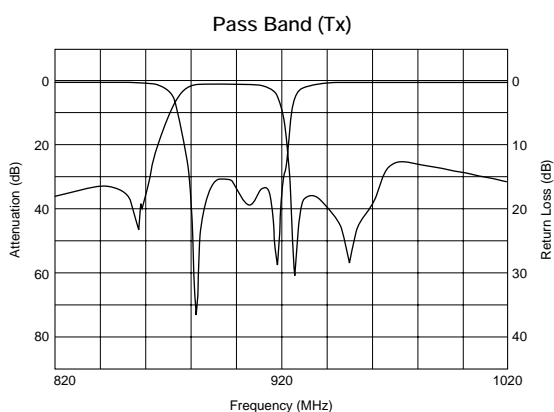

Part Number	fo (Tx) (MHz)	Bandwidth (Tx) (MHz)	IL at BW (dB max.)	Attenuation (dB min.)	fo (Rx) (MHz)	Bandwidth (Rx) (MHz)	IL at BW (dB max.)	Attenuation (dB min.)	Operation Temperature Range (°C)
DFYHA897MHFJAA	897.5	35	3.7	30 (925 to 960MHz)	942.5	35	4.4	40 (880 to 915MHz)	-35 to +85

DCS1800: DFYH(A) Series

■ Features

1. Low insertion loss for using high Q-value dielectric resonators
2. Small and light for using high dielectric constant ceramics
3. Excellent temperature stability for temperature compensated dielectric constant (0+5 ppm/degree C max.)
4. Excellent mechanical stability without vibratile structure
5. SMD and reflow soldering available
6. Mountable by automatic placement machine

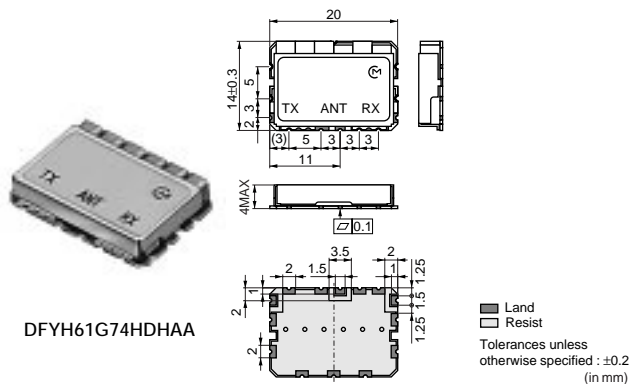

■ Characteristics

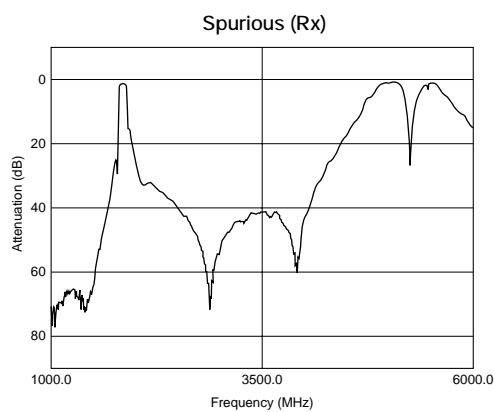
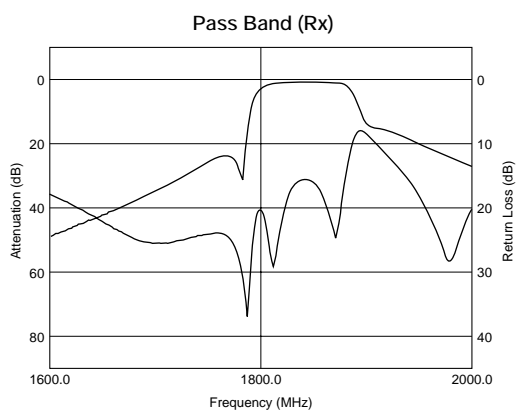
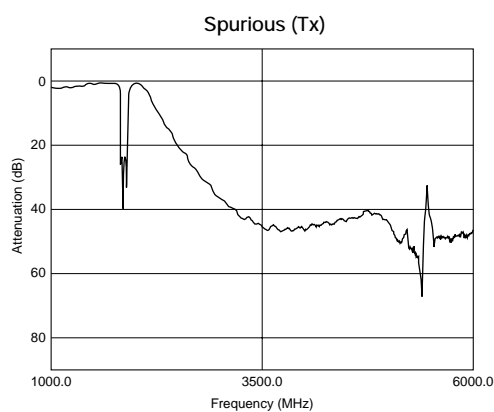
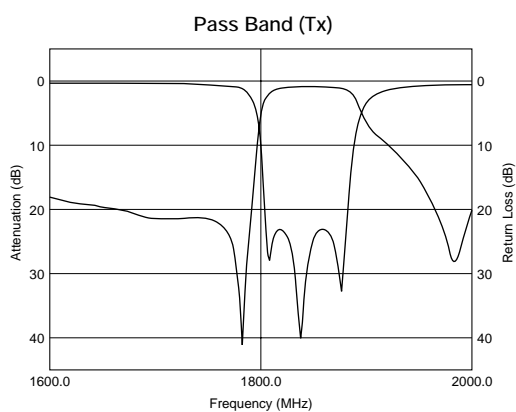

Part Number	fo (Tx) (MHz)	Bandwidth (Tx) (MHz)	IL at BW (dB max.)	Attenuation (dB min.)	fo (Rx) (MHz)	Bandwidth (Rx) (MHz)	IL at BW (dB max.)	Attenuation (dB min.)	Operation Temperature Range (°C)
DFYH61G74HDHAA	1747.5	75	2.3	20 (1805 to 1880MHz)	1842.5	75	2.7	20 (1710 to 1785MHz)	-30 to +85
DFYH61G74HDHAB	1747.5	75	2.0	15 (1805 to 1880MHz)	1842.5	75	3.0	20 (1710 to 1785MHz)	-30 to +85
DFYHA1G74HFHAB	1747.5	75	3.8	42 (1805 to 1880MHz)	1842.5	75	4.3	42 (1710 to 1785MHz)	-35 to +85

W-DCMA: DFYHA Series

■ Features

1. Low insertion loss for using high Q-value dielectric resonators
2. Small and light for using high dielectric constant ceramics
3. Excellent temperature stability for temperature compensated dielectric constant (0+5 ppm/degree C max.)
4. Excellent mechanical stability without vibratile structure
5. SMD and reflow soldering available
6. Mountable by automatic placement machine

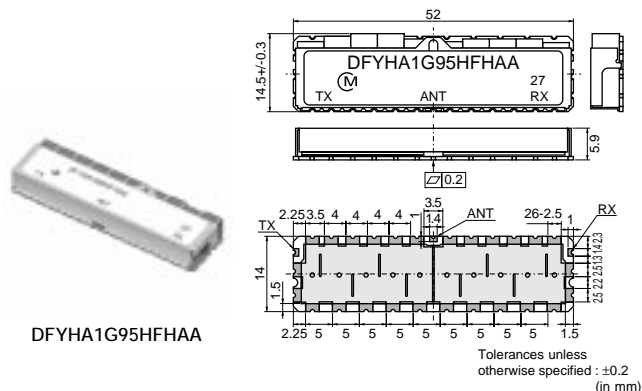

DFYHA1G95HFHAA

■ Characteristics

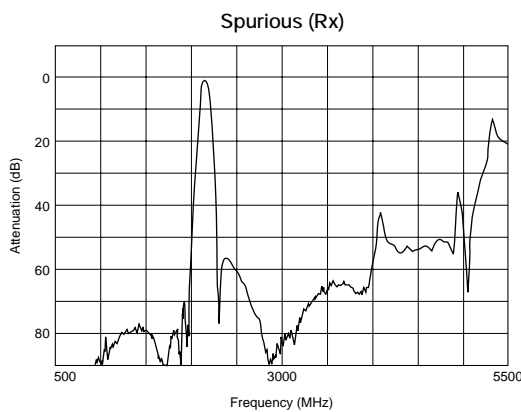
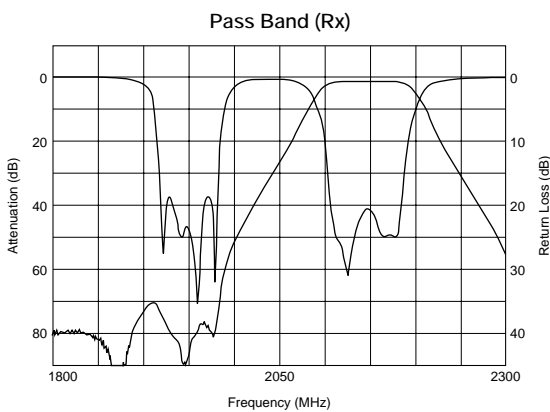
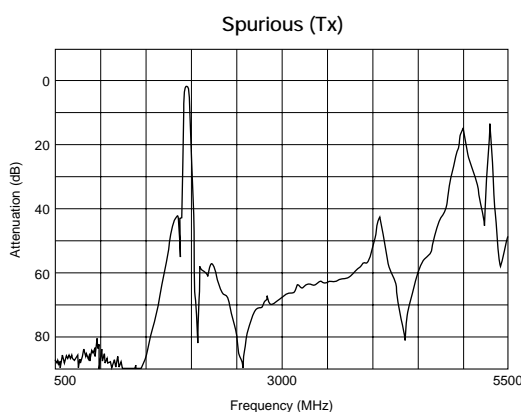
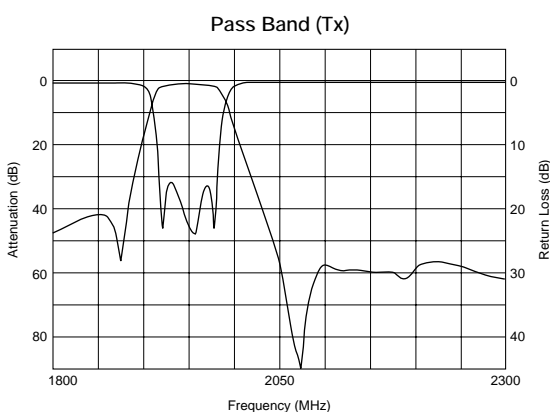

Part Number	fo (Tx) (MHz)	Bandwidth (Tx) (MHz)	IL at BW (dB max.)	Attenuation (dB min.)	fo (Rx) (MHz)	Bandwidth (Rx) (MHz)	IL at BW (dB max.)	Attenuation (dB min.)	Operation Temperature Range (°C)
DFYHA1G95HFHAA	1950	60	2.5	55 (2110 to 2170MHz)	2140	60	2.0	70 (1920 to 1980MHz)	-35 to +85

LMR: DFYH Series

■ Features

1. Low insertion loss for using high Q-value dielectric resonators
2. Small and light for using high dielectric constant ceramics
3. Excellent temperature stability for temperature compensated dielectric constant (0+5 ppm/degree C max.)
4. Excellent mechanical stability without vibratile structure
5. SMD and reflow soldering available
6. Mountable by automatic placement machine

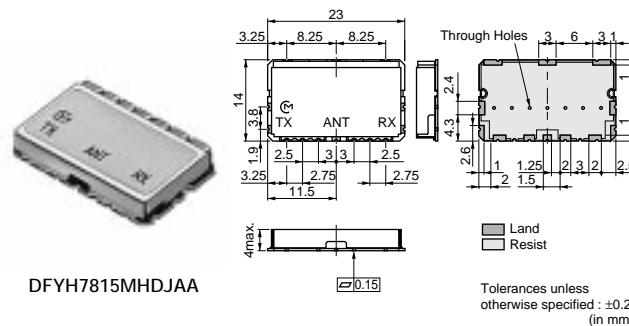

■ Characteristics

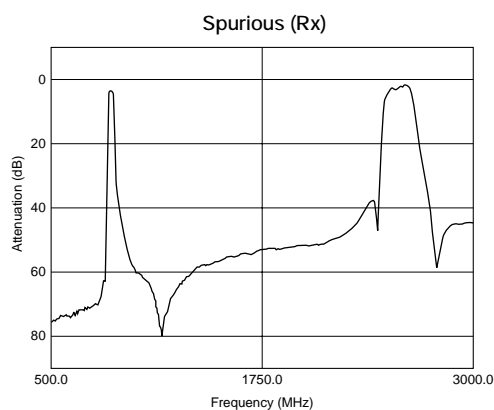
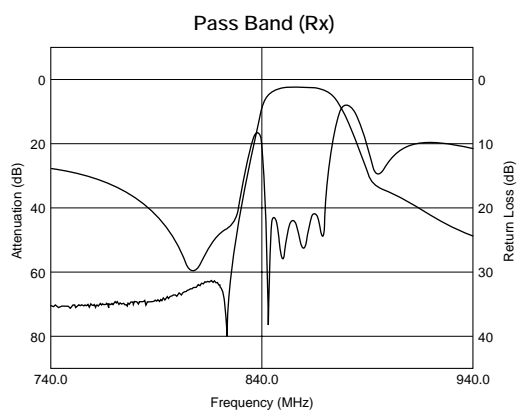
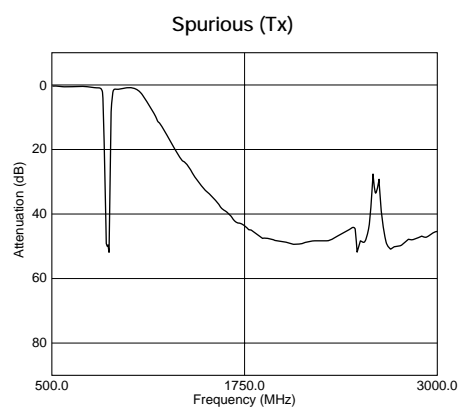
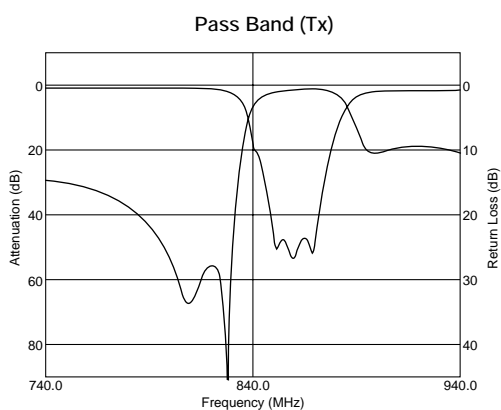

Part Number	fo (Tx) (MHz)	Bandwidth (Tx) (MHz)	IL at BW (dB max.)	Attenuation (dB min.)	fo (Rx) (MHz)	Bandwidth (Rx) (MHz)	IL at BW (dB max.)	Attenuation (dB min.)	Operation Temperature Range (°C)
DFYH7815MHDJAA	815	20	2.0	40 (850 to 870MHz)	860	20	4.0	57 (805 to 825MHz)	-30 to +85

MSAT: DFYF Series

■ Features

1. Low insertion loss for using high Q-value dielectric resonators
2. Small and light for using high dielectric constant ceramics
3. Excellent temperature stability for temperature compensated dielectric constant (0+5 ppm/degree C max.)
4. Excellent mechanical stability without vibratile structure

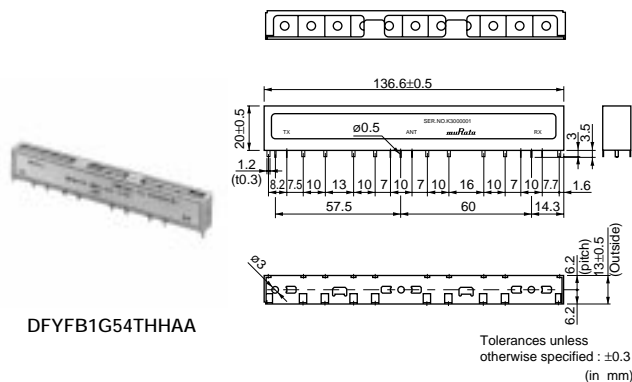

DFYFB1G54THHAA

■ Characteristics

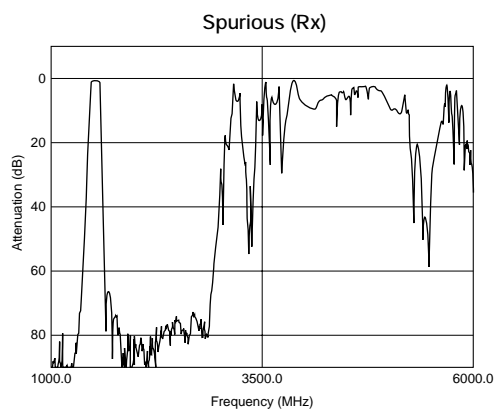
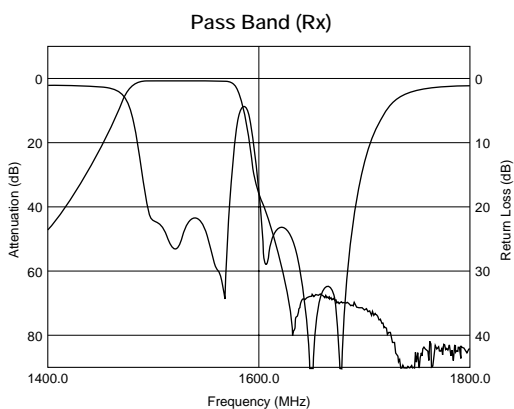
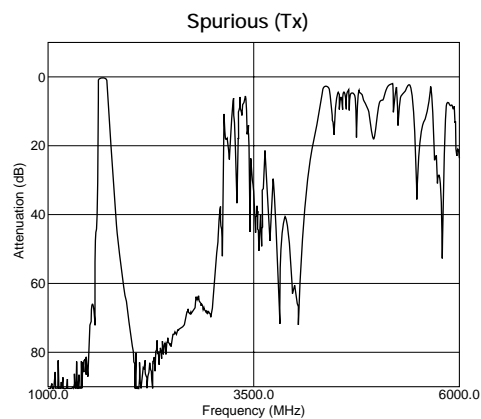
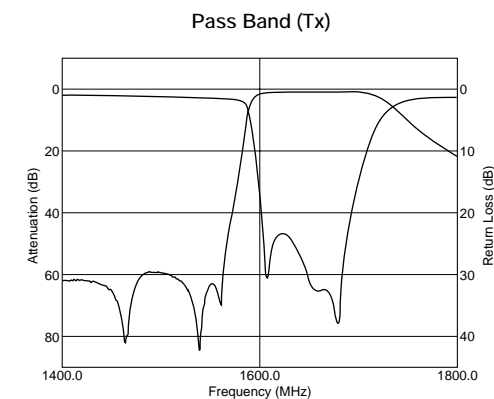

Part Number	fo (Tx) (MHz)	Bandwidth (Tx) (MHz)	IL at BW (dB max.)	Attenuation (dB min.)	fo (Rx) (MHz)	Bandwidth (Rx) (MHz)	IL at BW (dB max.)	Attenuation (dB min.)	Operation Temperature Range (°C)
DFYFB1G54THHAA	1643.5	34	1.0	60 (1525 to 1559MHz)	1542	34	1.2	65 (1626.5 to 1660.5MHz)	-30 to +85

Notice/Packaging/Soldering and Mounting

■ Notice

1. When handling products, be careful not to damage outer electrode. If you damage outer electrode, the device may not meet specifications.
2. When handling products, be careful not to touch outer electrode with bare hand. If you touch outer electrode with bare hand, the soldering performance of the device is reduced.
3. Do not apply excessive pressure or shock to product in handling or transportation because the ceramic material which is used inside might be damaged.

■ Reel

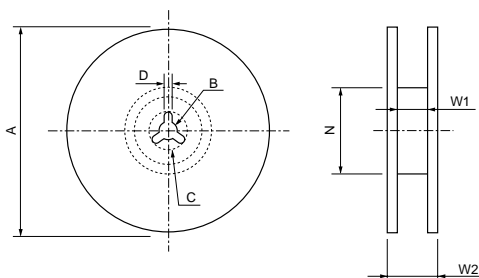

Wide	A±2.0	B±0.5	C±0.8	D±0.5	N min.	W1±1.5	W2 max.
12	ø178	ø13	ø21	2	ø50	13.5	18.5
	ø330	ø13	ø21	2	ø50	13.5	18.5
16	ø178	ø13	ø21	2	ø50	17.5	23
	ø330	ø13	ø21	2	ø50	17.5	23
24	ø330	ø13	ø21	2	ø50	25.5	31
32	ø330	ø13	ø21	2	ø50	33.5	39
44	ø330	ø13	ø21	2	ø50	45.5	51

(in mm)

■ Reflow Soldering Conditions

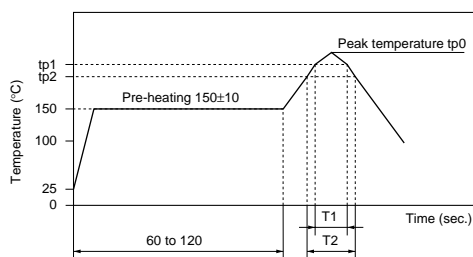

Measuring point of temperature : IN-OUT Terminals of The Device
Reflow Soldering : Both Convection and Infrared Rays, Hot Air and Hot Plate

	tp0 (°C)	tp1 (°C)	T1 (sec.)	tp2 (°C)	T2 (sec.)
Reflow standard condition	225±5	220	10 max.	200	20 to 40
Test condition of reflow heat resistance	260 max.	250	10 to 20	200	60 to 100

■ Allowable Reflow Soldering Temperature and Time

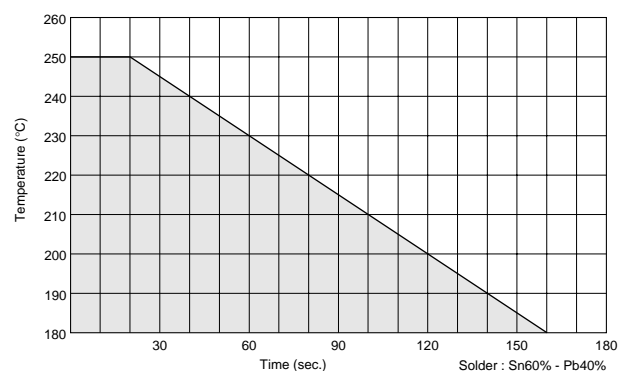

⚠Note:

1. Export Control

⟨For customers outside Japan⟩

Murata products should not be used or sold for use in the development, production, stockpiling or utilization of any conventional weapons or mass-destructive weapons (nuclear weapons, chemical or biological weapons, or missiles), or any other weapons.

⟨For customers in Japan⟩

For products which are controlled items subject to the "Foreign Exchange and Foreign Trade Law" of Japan, the export license specified by the law is required for export.

2. Please contact our sales representatives or product engineers before using the products in this catalog for the applications listed below, which require especially high reliability for the prevention of defects which might directly damage to a third party's life, body or property, or when one of our products is intended for use in applications other than those specified in this catalog.

- | | |
|-----------------------------|---|
| ① Aircraft equipment | ② Aerospace equipment |
| ③ Undersea equipment | ④ Power plant equipment |
| ⑤ Medical equipment | ⑥ Transportation equipment (vehicles, trains, ships, etc.) |
| ⑦ Traffic signal equipment | ⑧ Disaster prevention / crime prevention equipment |
| ⑨ Data-processing equipment | ⑩ Application of similar complexity and/or reliability requirements to the applications listed in the above |

3. Product specifications in this catalog are as of October 2003. They are subject to change or our products in it may be discontinued without advance notice. Please check with our sales representatives or product engineers before ordering. If there are any questions, please contact our sales representatives or product engineers.

4. Please read rating and ⚠CAUTION (for storage, operating, rating, soldering, mounting and handling) in this catalog to prevent smoking and/or burning, etc.

5. This catalog has only typical specifications because there is no space for detailed specifications. Therefore, please approve our product specifications or transact the approval sheet for product specifications before ordering.

6. Please note that unless otherwise specified, we shall assume no responsibility whatsoever for any conflict or dispute that may occur in connection with the effect of our and/or a third party's intellectual property rights and other related rights in consideration of your use of our products and/or information described or contained in our catalogs. In this connection, no representation shall be made to the effect that any third parties are authorized to use the rights mentioned above under licenses without our consent.

7. No ozone depleting substances (ODS) under the Montreal Protocol are used in our manufacturing process.