

- NOTES:**
- FOR MATERIAL SPECIFICATION SEE NOTE 1. ON SHEET 2.
  - FOR RECOMMENDED P.C.B. HOLE PATTERN, PART No's AND UNSTATED DIMENSIONS SEE SHEET 2.
  - PRODUCT SPEC.No.: PS-99020-0015.
  - THIS RIB IS NOT PRESENT ON 10 & 14 CKT PARTS.

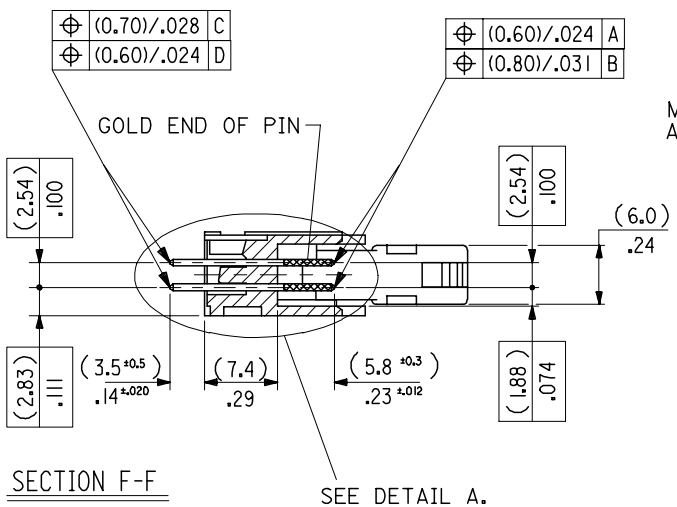

DIMENSIONS FOR SELECTIVE PLATING'S, SCALE 4:1

ADDED SHT 9 EC NO: E2007-0243 DRWN: DNASZKI, EMI CZ 2007/01/10 CHKD: J. DENNEHY 2007/01/22 APPR: DENNEHY 2007/01/23	QUALITY SYMBOLS ▽=0 ▽=0	GENERAL TOLERANCES (UNLESS SPECIFIED)		DIMENSION STYLE MM/IN		SCALE 2:1	DESIGN UNITS METRIC	THIRD ANGLE PROJECTION	
		mm	INCH	DRAWN BY POB	DATE 1990/08/03				TITLE QF50 SRD HDR VT W/ELV
G REV	DESCRIPTION	4 PLACES	± ---	± ---	DRAWN BY JDENNEHY	DATE 2004/11/24	MOLEX INCORPORATED DOCUMENT NO. SDA-90663E SHEET NO. 1 OF 9		
		3 PLACES	± ---	± .008	CHECKED BY JDENNEHY	DATE 2004/11/24			
		2 PLACES	± 0.20	± .008	APPROVED BY JDENNEHY	DATE 2004/11/24			
		1 PLACE	± 0.20	± ---	MATERIAL NO. SEE SHEET 2 DOCUMENT NO. SDA-90663E				
		ANGULAR ± 2 °		DRAFT WHERE APPLICABLE MUST REMAIN WITHIN DIMENSIONS					

(78.74)/3.100	(86.34)/3.400	(90.52)/3.564	(96.62)/3.804	(100.74)/3.966	90663-1641	90663-1642	90663-1643		64
(73.66)/2.900	(81.26)/3.200	(85.44)/3.364	(91.54)/3.604	(95.66)/3.766	↑ -1601	↑ -1602	↑ -1603		60
(60.96)/2.400	(68.56)/2.700	(72.74)/2.864	(78.84)/3.104	(82.96)/3.266	↑ -1501	↑ -1502	↑ -1503	90663-1509	50
(48.26)/1.900	(55.86)/2.200	(60.04)/2.364	(66.14)/2.604	(70.26)/2.766	↑ -1401	↑ -1402	↑ -1403	↑ -1409	40
(40.64)/1.600	(48.24)/1.900	(52.42)/2.064	(58.52)/2.304	(62.64)/2.466	↑ -1341	↑ -1342	↑ -1343	↑ -1349	34
(35.56)/1.400	(43.16)/1.700	(47.34)/1.864	(53.44)/2.104	(57.56)/2.266	↑ -1301	↑ -1302	↑ -1303	↑ -1309	30
(30.48)/1.200	(38.08)/1.500	(42.26)/1.664	(48.36)/1.904	(52.48)/2.066	↑ -1261	↑ -1262	↑ -1263	↑ -1269	26
(22.86)/.900	(30.46)/1.200	(34.64)/1.364	(40.74)/1.604	(44.86)/1.766	↑ -1201	↑ -1202	↑ -1203	↑ -1209	20
(17.78)/.700	(25.38)/1.000	(29.56)/1.164	(35.66)/1.404	(39.78)/1.566	↑ -1161	↑ -1162	↑ -1163	↑ -1169	16
(15.24)/.600	(22.84)/.900	(27.02)/1.064	(33.12)/1.304	(37.24)/1.466	↑ -1141	↑ -1142	↑ -1143	↑ -1149	14
(10.16)/.400	(17.76)/.700	(21.94)/.864	(28.04)/1.104	(32.16)/1.266	↓ 90663-1101	↓ 90663-1102	↓ 90663-1103	↓ 90663-1109	10
A	B	C	D	E	ENG. NO. GS1 PLATING	ENG. NO. GS2 PLATING	ENG. NO. GS3 PLATING	ENG. NO. PRE TIN	NO. OF CKTS.

**NOTES**

**1.MATERIAL**

HEADER : GLASS FILLED POLYESTER (UL 94V0), COLOUR - BLACK.  
 PINS : BRASS SIZE □ (0.635)/.025 .  
 LEVER : GLASS FILLED POLYESTER (UL 94V0), COLOUR - BLACK.

**2.COLOUR IDENTIFICATION MARK FOR PLATING OPTIONS.**

90663-1\*\*1, (1um)/.039uin MIN. NICKEL UNDERPLATE. CONTACT AREA  
 GS1 PLATING (0.1um)/.004uin MIN. GOLD. SOLDER AREA (3um)/.118uin MIN.  
 TIN. COLOUR MARK: YELLOW.  
 90663-1\*\*2, (1um)/.039uin MIN. NICKEL UNDERPLATE. CONTACT AREA  
 GS2 PLATING (0.76um)/.030uin MIN. GOLD. SOLDER AREA (3um)/.118uin MIN.  
 TIN. COLOUR MARK: BROWN.  
 90663-1\*\*3, (1um)/.039uin MIN. NICKEL UNDERPLATE. CONTACT AREA  
 GS3 PLATING (0.25um)/.010uin MIN. GOLD. SOLDER AREA (3um)/.118uin MIN.  
 TIN. COLOUR MARK: BLUE.  
 90663-1\*\*9, (0.5-1um)/.020-.040uin NICKEL UNDER (1.0-3.0um)/.039-.118uin TIN.  
 COLOUR MARK: BLACK, (NO MARK).

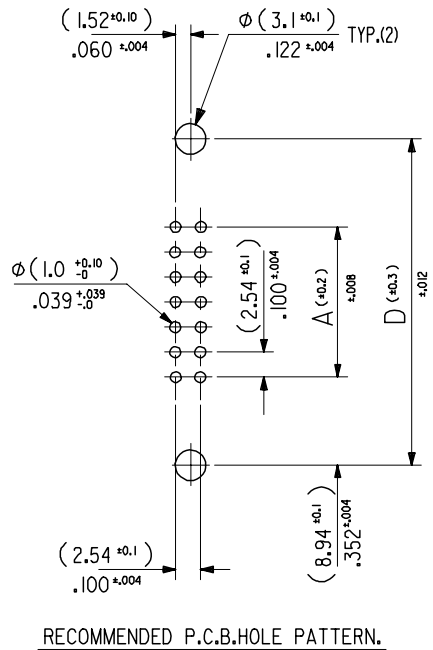

ADDED SHT 9 EC NO: E2007-0243 DRWN: MWASZKI EMI CZ 2007/01/10 CHKD: J. DENNEHY 2007/01/22 APPR: DENNEHY 2007/01/23	QUALITY SYMBOLS ▽=0 ▽=0	GENERAL TOLERANCES (UNLESS SPECIFIED)	DIMENSION STYLE MM/IN	SCALE 2:1	DESIGN UNITS METRIC	THIRD ANGLE PROJECTION
		4 PLACES ± --- ± --- 3 PLACES ± --- ± .008 2 PLACES ± 0.20 ± .008 1 PLACE ± 0.20 ± --- ANGULAR ± 2 °	DRAWN BY POB DATE 1990/08/03	TITLE QF50 SRD HDR VT W/ELV		
		DRAFT WHERE APPLICABLE MUST REMAIN WITHIN DIMENSIONS	APPROVED BY JDENNEHY DATE 2004/11/24	MOLEX INCORPORATED		SHEET NO. 2 OF 9
			MATERIAL NO. SEE CHART	DOCUMENT NO. SDA-90663E	THIS DRAWING CONTAINS INFORMATION THAT IS PROPRIETARY TO MOLEX INCORPORATED AND SHOULD NOT BE USED WITHOUT WRITTEN PERMISSION	