

10 9 8 7 6 5 4 3 2 1

F

E

D

C

B

A

F

E

D

C

B

A

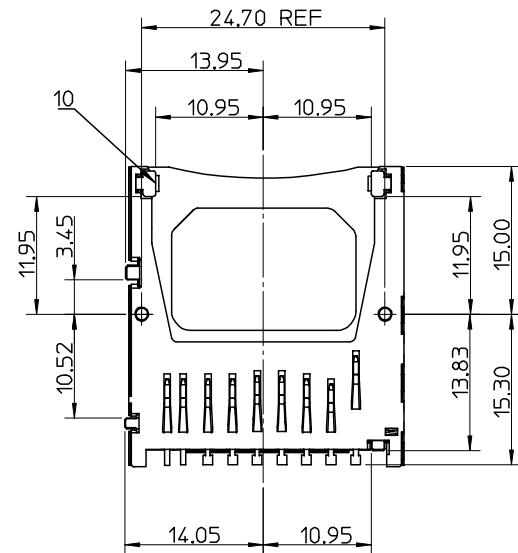
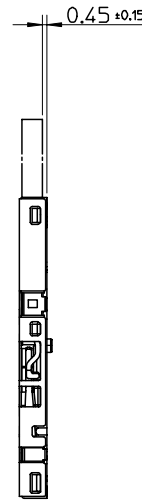
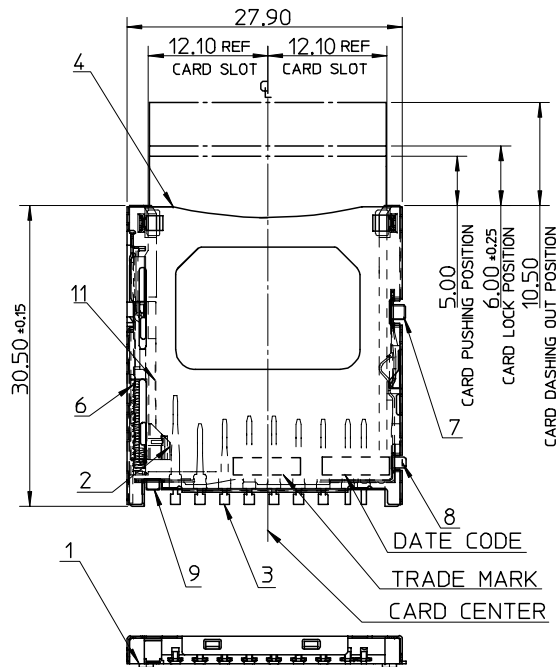
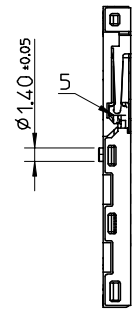
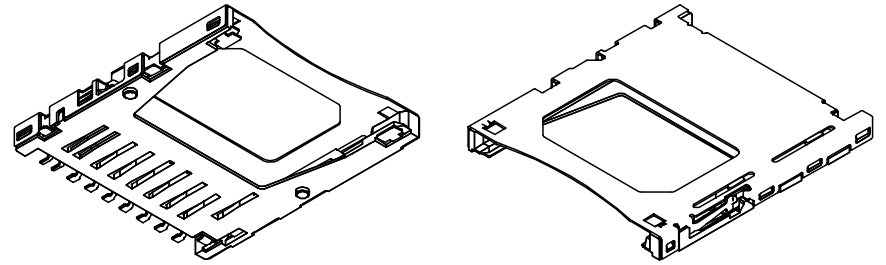
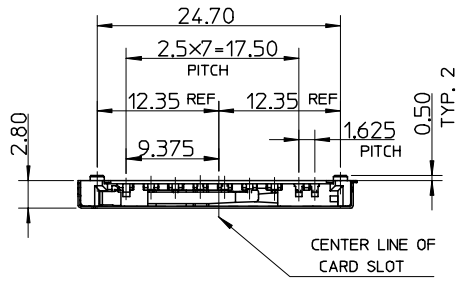

RELEASE TO TOOLING
 EC NO:
 DRAWN: MCHANG 2003/04/30
 CHKD: WILSON
 APPR:

REV	DESCRIPTION
A	

QUALITY SYMBOLS	
	+ 0
	C - 0
	S - 0

GENERAL TOLERANCES (UNLESS SPECIFIED)	
4 PLACES	± ---
3 PLACES	± ---
2 PLACES	± 0.25
1 PLACE	± 0.25
ANGULAR ± 3 °	
DRAFT WHERE APPLICABLE	
MUST REMAIN WITHIN DIMENSIONS	

SCALE	DESIGN UNITS	THIRD ANGLE PROJECTION		REVISE ON CAD ONLY	
3:1	METRIC				
DIMENSION STYLE		TITLE			
MM ONLY		SD MEMORY CARD CONN. FOR LEAD FREE			
DRAWN BY DATE		MATERIAL NO. DOCUMENT NO. SHEET NO.			
MAX 2003/01/30		67600-0004		SD-67600-004 1 OF 2	
CHECKED BY DATE		MOLEX INCORPORATED			
WILSON 2003/01/30					
APPROVED BY DATE		THIS DRAWING CONTAINS INFORMATION THAT IS PROPRIETARY TO MOLEX INCORPORATED AND SHOULD NOT BE USED WITHOUT WRITTEN PERMISSION			
ERICK 2003/01/30		A3			

9 8 7 6 5 4 3 2 1

