

SPECIFICATION FOR APPROVAL

REF : 20100129-I

PAGE: 1/6

PROD. NAME	WOUND CHIP INDUCTOR	CUSTOMER :	
		CUST P/N NO.:	

I . CONFIGURATION & DIMENSIONS :

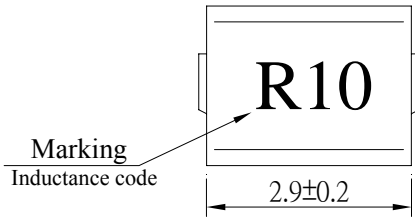

- A : 3.2 ± 0.4 m/m
- B : 2.5 ± 0.2 m/m
- C : 2.2 ± 0.2 m/m
- E : 1.0 ± 0.2 m/m
- F : $0.6^{+0.3}_{-0}$ m/m
- ※ $\Delta K = |K1 - K2| = 0.25^{+0}$ m/m

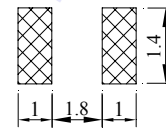
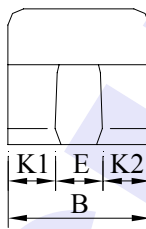
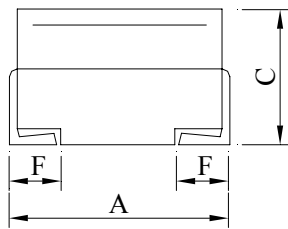

(PCB Pattern)

II . SCHEMATIC DIAGRAM :

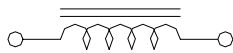

III . MATERIALS :

- a . Core : Ferrite DR core
- b . Wire : Enamelled copper wire (class H)
- c . Terminal : Cu/Sn
- d . Encapsulate : Epoxy novolac molding compound
- e . Remark : Products comply with RoHS' requirements

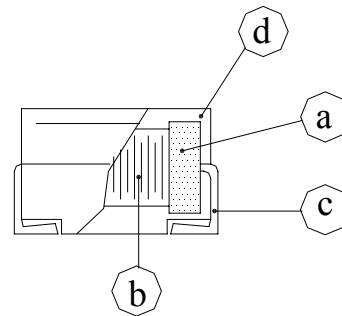

IV . GENERAL SPECIFICATION :

- a . Temp. rise : 20°C max.
- b . Ambient temp. : 100°C max.
- c . Storage temp. : -40°C ---- $+125^{\circ}\text{C}$
- d . Operating temp. : -40°C ---- $+125^{\circ}\text{C}$
- e . Terminal pull strength : 1.5 kg min.
- f . Rated current : Current cause
inductance drop within 10%
- g . Resistance to solder heat : 260°C .10 secs.
- h . Resistance to solvent : Per MIL-STD-202F

Reflow profile
 Peak Temp : 250°C max.
 Max time above 245°C : 20~40sec max.
 Max time above 217°C : 60~150sec max.
 200°C ~ 250°C Average Ramp-up Rate : $3^{\circ}\text{C}/\text{second}$ max.

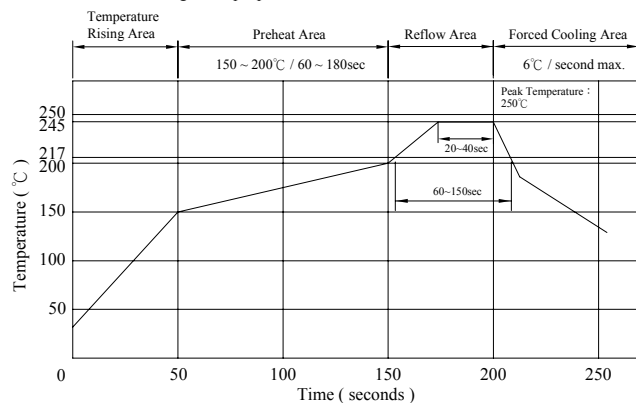

SPECIFICATION FOR APPROVAL

PROD. NAME	WOUND CHIP INDUCTOR	CUSTOMER.	
		CUST P/N NO.:	

V . ELECTRICAL CHARACTERISTICS :

DWG No.	Inductance (μ H)	Q min.	Test Freq (MHz)	SRF (MHz) min.	RDC (Ω) max.	IDC (mA) max
WL322522-R10M	0.120 \pm 20%	28	100.0	700	0.44	450

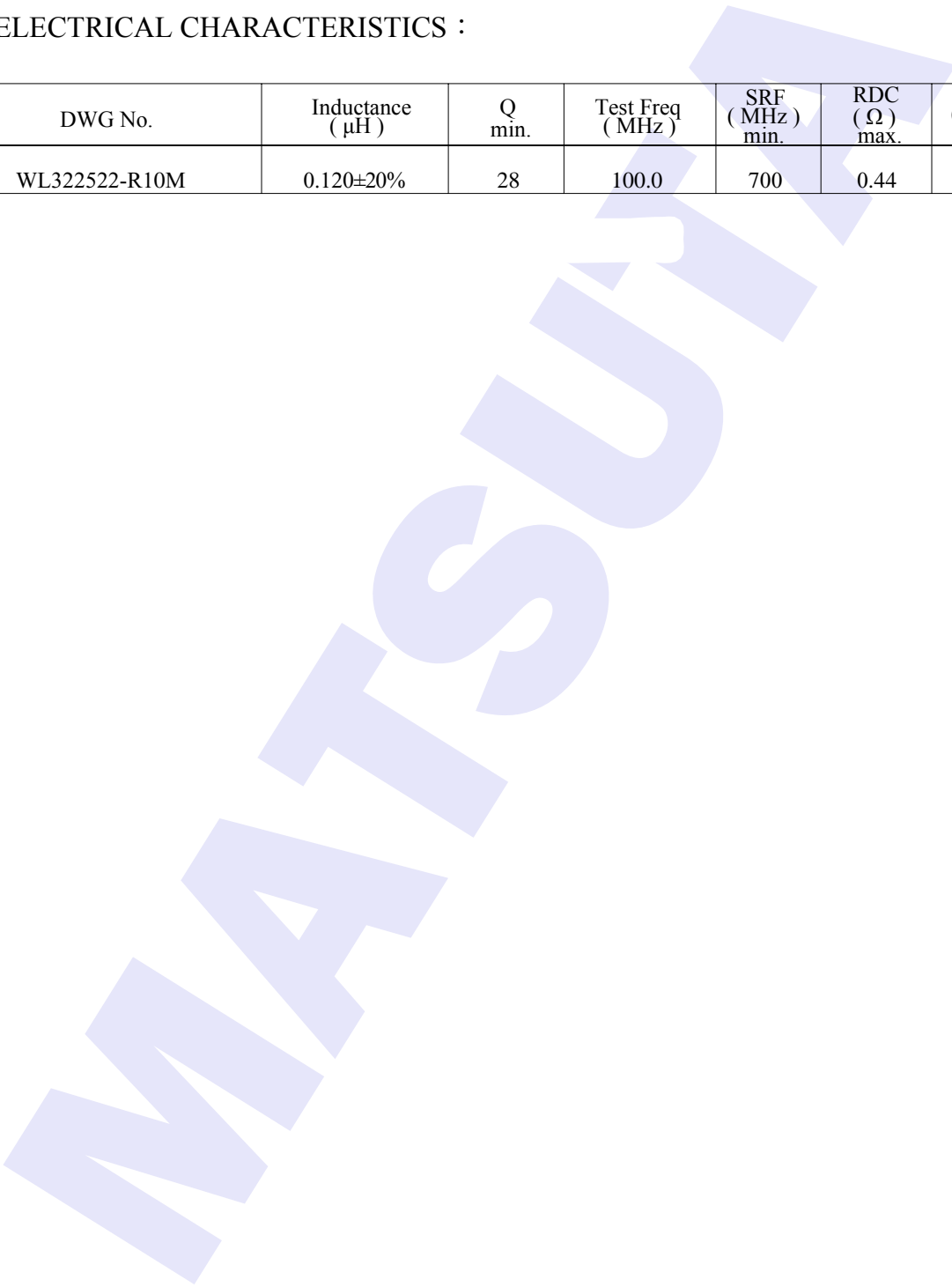

SPECIFICATION FOR APPROVAL

REF : 20100129-I

PAGE: 3/6

PROD. NAME	WOUND CHIP INDUCTOR	CUSTOMER :	
		CUST P/N NO.:	

VII . PACKAGING INFORMATION :

(1) Configuration

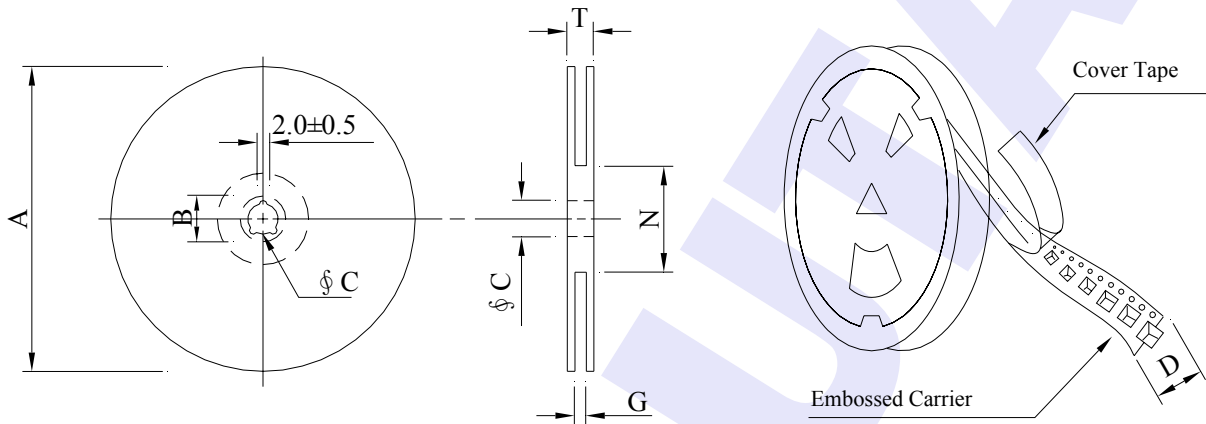

※Carrier Tape Width : D

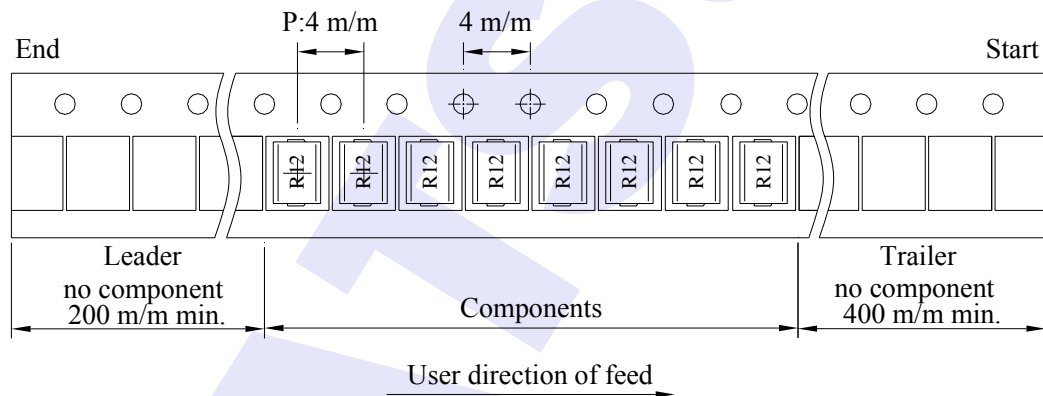

※ There is no differentiation or directions of polarity (marking) in the packaging method.

(2) Dimensions

Unit:m/m

Style	A	B	C	D	G	N	T
07 - 08	178	21±0.8	13	8	10 ⁺⁰	50 ⁻⁰	12.5
07(S) - 08	183	21±0.8	13	8	10 ⁺⁰	50 ⁻⁰	12.5
13 - 08	330	21±0.8	13±0.5	8	10 ⁺⁰	50 ⁻⁰	12.5

(3) Q'TY & G.W. Per package

Series	Inner : Reel			Outer : Carton		
	Q'TY (pcs)	G.W. (gw)	Style	Q'TY (pcs)	G.W. (Kg)	Size (cm)
WL3225	1,000	110	07 - 08	50,000	7.50	41 x 39 x 22
WL3225	2,000	220	07(S) - 08	100,000	15.00	41 x 39 x 22
WL3225	7,000	770	13 - 08	84,000	9.80	41 x 39 x 22

SPECIFICATION FOR APPROVAL

REF : 20100129-I

PAGE: 4/6

PROD. NAME	WOUND CHIP INDUCTOR	CUSTOMER :	
		CUST P/N NO.:	
IX . RELIABILITY TEST :			
Test item	Specification	Test condition / Test method	
● Electrical performance test			
Inductance L	Refer to standard electrical characteristic list	□HP4194A with HP-16034E test fixture	
Q			
Self resonance frequency SRF		□HP4291A with HP-16093A test fixture	
DC Resistance RDC		CH-502AC	
Rated current IDC		Applied the current to coils , The Inductance change shall be less than 10% to initial value & temperature rise shall not be more than 20°C	
Temperature rise test	20°C max.	1 . Applied the allowed DC current for 10 minutes 2 . Temperature measure by digital surface thermometer	
Over load test	After test , Inductors shall be no evidence of electrical and mechanical damage	Applied 2 times of rated allowed DC current to inductor for a period of 5 minutes	
Withstanding voltage test	After tset , Inductors shall be no evidence of electrical and mechanical damage	AC voltage of 1000VAC applied between inductors terminal and coating for 5 seconds	
Insulation resistance test	1000 MΩ min .	100 VDC applied between inductor terminal and coating	
● Mechanical performance test			
Vibration test (Low frequency)	1 . Inductors shall be no evidence of electrical and mechanical damage	1 . Amplitude : 1.5 m/m 2 . Frequency : 10 -- 55 -- 10 Hz / 1min. 3 . Direction : X , Y , Z 4 . Duration : 2 hrs / X , Y , Z	
Shock test	2 . Inductance shall not change more than±5%	Inductors shall be dropped 10 times from a height of 1m onto 3cm wooden board	
Resistance to soldering heat	3 . Q Shall not change more than ±20%	Temp : 260±5°C Time : 10±1.0 sec.	

SPECIFICATION FOR APPROVAL

REF : 20100129-I

PAGE: 5/6

PROD. NAME	WOUND CHIP INDUCTOR	CUSTOMER :													
		CUST P/N NO.:													
Terminal strength-pull test	Terminal shall not be loosened or ruptured	A 0.5kg load shall be applied to both Terminals in the axis direction for 1 minute .													
Solderability test	The terminal shall be at least 90% covered with solder	After fluxing , Inductor shall be dipped in a melted solder bath at 240±5°C for 5 seconds .													
Resistance to solvent test	There shall be no case deformation change in appearance or obliteration of marking	MIL-STD-202F , Method 215D													
● Climatic test															
Temperature characteristic	1 . Inductors shall be no evidence of electrical and mechanical damage 2 . Inductance shall not change more than ±10% 3 . Q shall not change more than ±20%	-40°C -- +125°C													
Humidity test		1 . Temp : 40±2°C 2 . R.H. : 90 -- 95% 3 . Time : 96±2 hours													
Cold test		1 . Temp : -25±2°C 2 . Time : 96±2 hours													
Thermal shock test		<table style="margin-left: auto; margin-right: auto; border-collapse: collapse;"> <tr> <td style="text-align: center;">→ Room temp</td> <td style="text-align: center;">→ -40±2°C</td> </tr> <tr> <td style="text-align: center;">15 mins</td> <td style="text-align: center;">30 mins</td> </tr> <tr> <td colspan="2" style="text-align: center;">→</td> </tr> <tr> <td style="text-align: center;">→ Room temp</td> <td style="text-align: center;">→ +125±2°C</td> </tr> <tr> <td style="text-align: center;">15 mins</td> <td style="text-align: center;">30 mins</td> </tr> <tr> <td colspan="2" style="text-align: center;">→</td> </tr> </table> Total : 5 cycles		→ Room temp	→ -40±2°C	15 mins	30 mins	→		→ Room temp	→ +125±2°C	15 mins	30 mins	→	
→ Room temp		→ -40±2°C													
15 mins		30 mins													
→															
→ Room temp	→ +125±2°C														
15 mins	30 mins														
→															
Dry heat test	1 . Temp : 85±2°C 2 . Time : 96±2 hours														
High temperature load life test	1 . Temp : 85±2°C 2 . Time : 1000±12 hours 3 . Load : Allowed DC current														
Humidity load life	There shall be no evidence of short or open circuiting	1 . Temp : 40±2°C 2 . R.H. : 90 -- 95% 3 . Time : 1000±12 hours 4 . Load : Allowed DC current													
● Note : Unless otherwise specified , Allow the specimen to stand at room temperature for 1 hour or more but not more than 2 hours , Measure the electrical and mechanical performances															

SPECIFICATION FOR APPROVAL

REF : 20100129-I

PAGE: 6/6

PROD. NAME	WOUND CHIP INDUCTOR	CUSTOMER :	
		CUST P/N NO.:	

X . UL CARD :

OBMW2 August 27, 1999

Magnet Wire-Component

ELEKTRISOLA (MALAYSIA) SDN BHD E143312
IALAN DAMN SATU IANDA BAIK 28750 BENTONG, PAHANG
DARUL MAKMUR MALAYSIA

Mtl Dsg	Mark Dsg	Coating Type		ANSI Typ	Temp Class
		BC	OC		
Estersol 160	E180	Polyesterimide (solderable)	—	MW-77	180
Amldester 200	A200	Polyesterimide	—	MW-74	200
Polysol-N 155	PN155	Polyurethane	Nylon	MW-80, MW-28	155, 100
Polysol 155	P155	Polyurethane	—	MW-79, MW-79	155, 130
Polysol 155g	Pg155	Polyurethane	—	MW-79	130
Polysol 155p	Pp155,Gp155	Polyurethane	—	MW-79	155
Polysol 160	P160	Polyurethane	—	MW-79	155
Polysol 180	P180	Polyurethane	—	MW-79	155
Polysol 170	P170 or G170	Polyurethane	—	MW-79	156
Polysol-N 180	PN180	Polyurethane	Nylon	—	180

Marking : Company name/material designation or marked designation and factory identification on package ok reel

See General Information preceding These Recognitions
 For use only in equipment where the acceptability of the combination is determined by Underwriters Laboratories Inc.

OMFZ2 March 4, 1994

Component-Plastics

CHANG CHUN PLASTICS CO LTD E59481 (S)
(F1-cont. from F card)

BM-21	ALL	0.79	94HB	50	50	50	—	—	—	—
BM-22	ALL	0.79	94HB	50	50	50	—	—	—	—
BM-23	ALL	0.79	94V-0	50	50	50	—	—	—	—
EME-1100	BK	0.84	94V-0	130	130	130	—	—	—	—
	BK	6.4	94V-0	130	130	130	—	—	—	—
EME-1200	BK	0.84	94V-0	130	130	130	—	—	—	—
	BK	6.4	94V-0	130	130	130	—	—	—	—
EME-5961C	BK	0.3	94V-0	130	130	130	—	—	—	—
	BK	3.1	94V-0	130	130	130	—	—	—	—

Reports: January 19, 1988: January 19, 1988: January 19, 1988: June 2, 1988;
 June 2, 1998; June 2, 1988.

Replaces E59481C dated February 7, 1989. (Cont. on C1 card)
 262854001 N7047 Underwriters Laboratories Inc.® D11/0018965