

# TRIAC (ISOLATED TYPE)

# TG70AA40/60

TG70AA40/60 are isolated mould triac suitable for wide range of applications like copier, microwave oven, solid state switch, motor control, light control and heater control.

- $I_{T(AV)}$  70A
- High surge capability 600A
- Isolated Mounting (AC650V)
- Tab Terminals

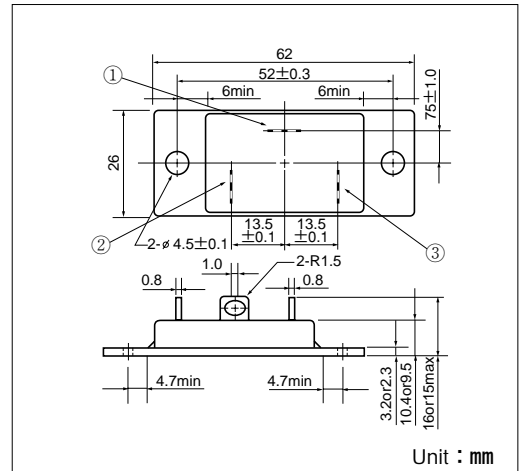
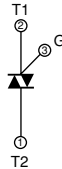

## Maximum Ratings

( $T_j=25^\circ\text{C}$  unless otherwise specified)

Symbol	Item	Ratings		Unit
		TG70AA40	TG70AA60	
$V_{DRM}$	Repetitive Peak Off-State Voltage	400	600	V
$V_{DSM}$	Non-Repetitive Peak Off-State Voltage	450	650	V

Symbol	Item	Conditions	Ratings	Unit
$I_{T(RMS)}$	R.M.S. On-State Current	$T_c=58^\circ\text{C}$	70	A
$I_{TSM}$	Surge On-State Current	One cycle, 50Hz/60Hz, peak, non-repetitive	1080/1200	A
$I^2t$	$I^2t$		6000	$\text{A}^2\text{S}$
$P_{GM}$	Peak Gate Power Dissipation		10	W
$P_{G(AV)}$	Average Gate Power Dissipation		1	W
$I_{GM}$	Peak Gate Current		3	A
$V_{GM}$	Peak Gate Voltage		10	V
$di/dt$	Critical Rate of Rise of On-State Current	$I_G=100\text{mA}$ , $T_j=25^\circ\text{C}$ , $V_D=\frac{1}{2}V_{DRM}$ , $dI_G/dt=1\text{A}/\mu\text{s}$	50	$\text{A}/\mu\text{s}$
$T_j$	Operating Junction Temperature		-40 to +125	$^\circ\text{C}$
$T_{stg}$	Storage Temperature		-40 to +125	$^\circ\text{C}$
$V_{iso}$	Isolation Breakdown Voltage (R.M.S.)	A.C.1 minute	2500	V
	Mounting Torque (Mounting M4)	Recommended Value 1.0-1.4 (10-14)	1.5 (15)	$\text{N}\cdot\text{m}$ ( $\text{kgf}\cdot\text{cm}$ )
	Mass			g

## Electrical Characteristics

Symbol	Item	Conditions	Ratings			Unit
			Min.	Typ.	Max.	
$I_{DRM}$	Repetitive Peak Off-State Current	$V_D=V_{DRM}$ , Single phase, half wave, $T_j=125^\circ\text{C}$			10	mA
$V_{TM}$	Peak On-State Voltage	On-State Current, 100A, $I_T=25\text{A}$ , Inst. measurement			1.35	V
$I_{GT1}^+$	Gate Trigger Current	$T_j=25^\circ\text{C}$ , $I_T=1\text{A}$ , $V_D=6\text{V}$			50	mA
$I_{GT1}^-$		$T_j=25^\circ\text{C}$ , $I_T=1\text{A}$ , $V_D=6\text{V}$			50	
$I_{GT3}^+$						
$I_{GT3}^-$		$T_j=25^\circ\text{C}$ , $I_T=1\text{A}$ , $V_D=6\text{V}$			50	
$V_{GT1}^+$	Gate Trigger Voltage	$T_j=25^\circ\text{C}$ , $I_T=1\text{A}$ , $V_D=6\text{V}$			3	V
$V_{GT1}^-$		$T_j=25^\circ\text{C}$ , $I_T=1\text{A}$ , $V_D=6\text{V}$			3	
$V_{GT3}^+$						
$V_{GT3}^-$		$T_j=25^\circ\text{C}$ , $I_T=1\text{A}$ , $V_D=6\text{V}$			3	
$V_{GD}$	Non-Trigger Gate Voltage	$T_j=125^\circ\text{C}$ , $V_D=\frac{1}{2}V_{DRM}$	0.2			V
$dv/dt$	Critical Rate of Rise on-State Voltage, min.	$T_j=125^\circ\text{C}$ , $V_D=\frac{2}{3}V_{DRM}$ , Exponential wave.	50			$\text{V}/\mu\text{s}$
$(dv/dt)_c$	Critical Rate of Rise off-State Voltage at commutation	$T_j=125^\circ\text{C}$ , $V_D=\frac{2}{3}V_{DRM}$ , $(di/dt)_c=8\text{A}/\text{ms}$	6			$\text{V}/\mu\text{s}$
$I_H$	Holding Current	$T_j=25^\circ\text{C}$		50	100	mA
$R_{th(j-c)}$	Thermal Impedance	Junction to case			0.83	$^\circ\text{C}/\text{W}$

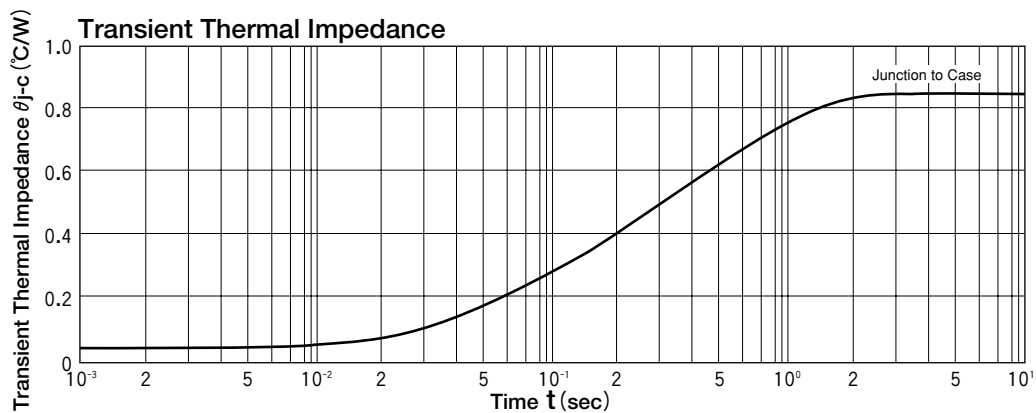
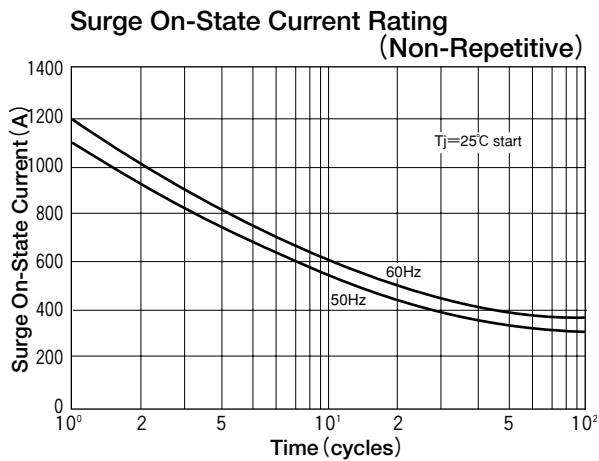
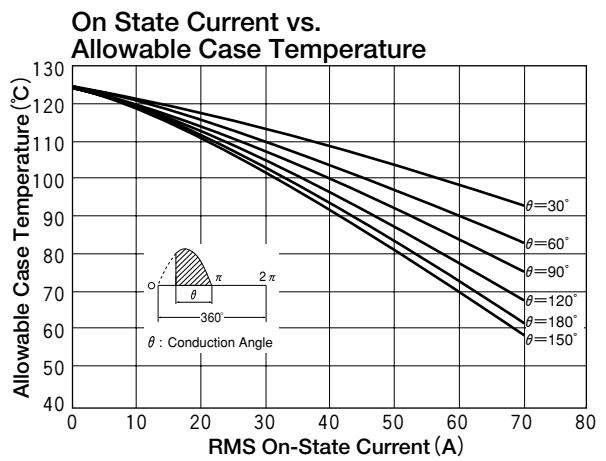
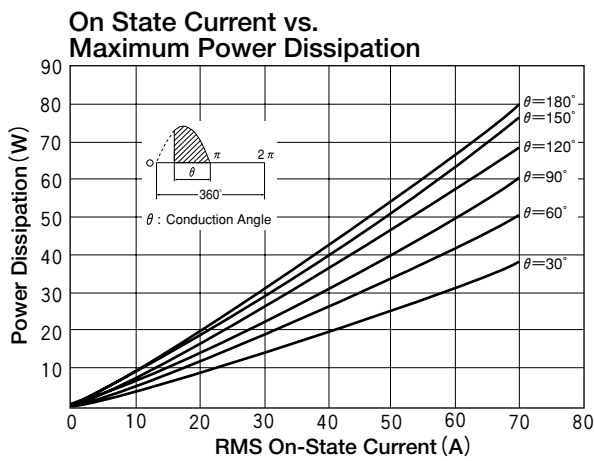
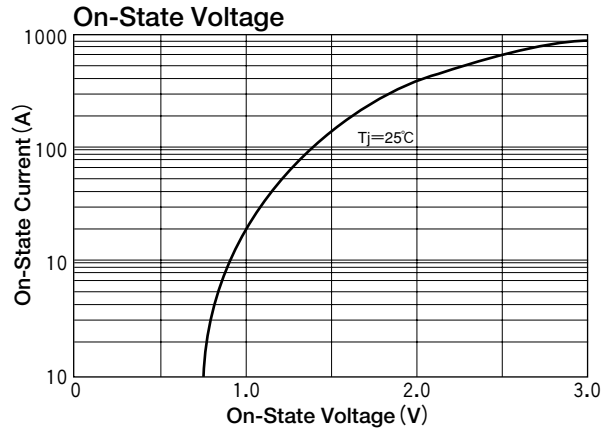
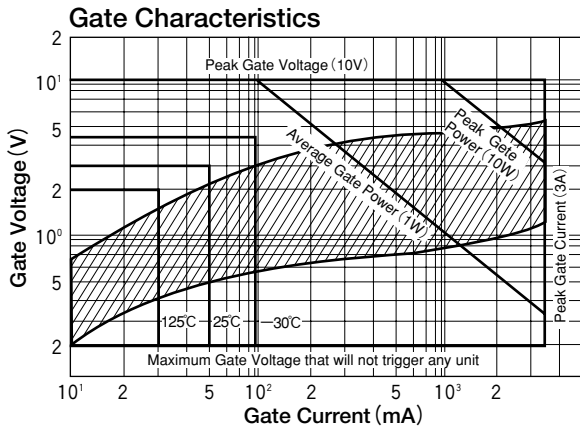

This datasheet has been download from:

[www.datasheetcatalog.com](http://www.datasheetcatalog.com)

Datasheets for electronics components.