



Model Number

ENA36IL-R***-SSI

Features

- Very small housing
- Up to 32 Bit multiturn
- SSI interface
- Free of wear magnetic sampling
- High resolution and accuracy

Description

The ENA36IL series are high precision encoders with internal magnetic sampling.

This multiturn absolute encoder transmits a position value corresponding to the shaft setting via the SSI interface (Synchronous Serial Interface).

The control module sends a start sequence to the absolute encoder to obtain the position data. The rotary encoder then sends the position data synchronous to the cycles of the control module. It is possible to select the counting direction with the function input.

Technical data

General specifications

Detection type	magnetic sampling
Device type	Absolute encoders
Linearity error	$\leq \pm 0.1^\circ$

Electrical specifications

Operating voltage U_B	4.75 ... 30 V DC
No-load supply current I_0	typ. 50 mA
Power consumption P_0	≤ 1.5 W
Output code	Gray code, binary code
Code course (counting direction)	adjustable

Interface

Interface type	SSI
Resolution	
Single turn	up to 16 Bit
Multiturn	up to 16 Bit
Overall resolution	up to 32 Bit
Transfer rate	0.1 ... 2 MBit/s
Cycle time	< 100 μ s
Standard conformity	RS 422

Input 1

Input type	Selection of counting direction (cw/ccw)
Signal voltage	
High	4.75 V ... U_B (cw descending)
Low	0 ... 2 V or unconnected (cw ascending)
Input current	< 6 mA
Switch-on delay	< 250 ms

Input 2

Input type	zero-set (PRESET 1) with falling edge
Signal voltage	
High	4.75 V ... U_B
Low	0 ... 2 V
Input current	< 6 mA
Signal duration	≥ 1.1 s

Connection

Connector	M12 connector, 8-pin
Cable	$\varnothing 6$ mm, 4 x 2 x 0.14 mm ²

Standard conformity

Degree of protection	DIN EN 60529, IP65 or IP54
Climatic testing	DIN EN 60068-2-3, no moisture condensation
Emitted interference	EN 61000-6-4:2007
Noise immunity	EN 61000-6-2:2005
Shock resistance	DIN EN 60068-2-27, 100 g, 6 ms
Vibration resistance	DIN EN 60068-2-6, 10 g, 10 ... 1000 Hz

Ambient conditions

Operating temperature	-40 ... 85 °C (-40 ... 185 °F)
Storage temperature	-40 ... 85 °C (-40 ... 185 °F)
Relative humidity	98 % , no moisture condensation

Mechanical specifications

Material	
Housing	nickel-plated steel
Flange	aluminum
Shaft	Stainless steel
Mass	approx. 150 g
Rotational speed	max. 12000 min ⁻¹
Moment of inertia	30 gcm ²
Starting torque	< 3 Ncm

Dimensions

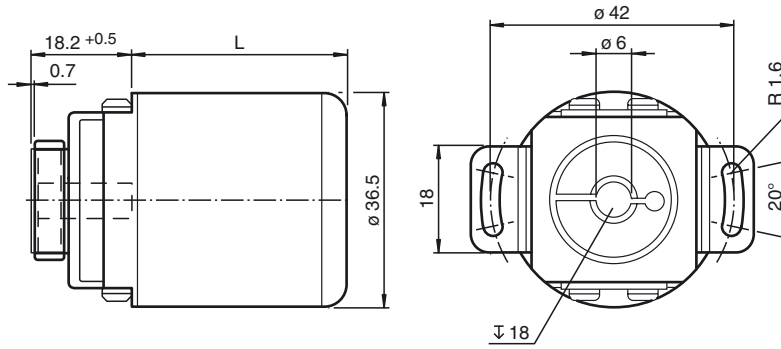

Degree of protection	L [mm]	
	Axial output	Radial output
IP54	36	
IP64/IP65	36	32

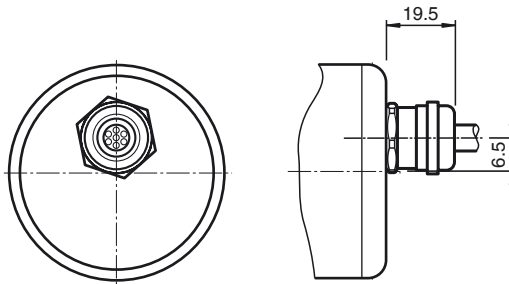

Output, axial, IP64/IP65

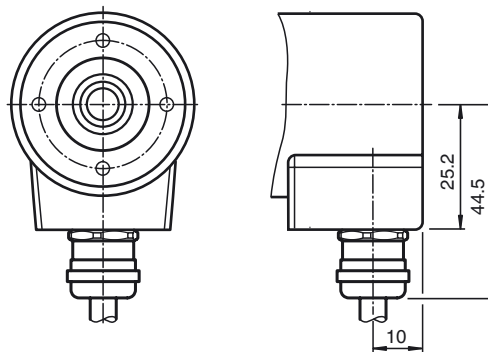

Output, radial, IP64/IP65

Release date: 2015-01-09 15:14 Date of issue: 2016-01-26 t166924_eng.xml

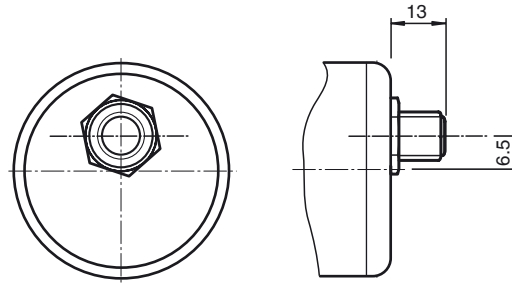

Output, axial, IP64/IP65

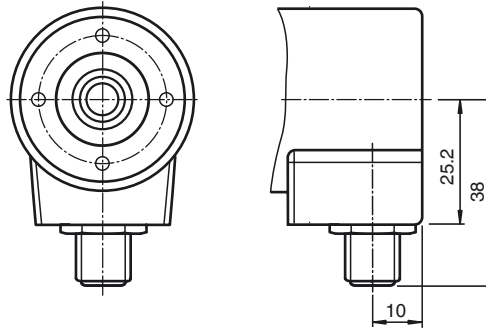

Output, radial, IP64/IP65

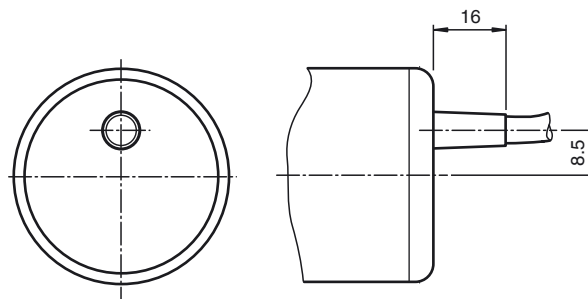

Output, axial, IP54

Release date: 2015-01-09 15:14 Date of issue: 2016-01-26 t166924_eng.xml

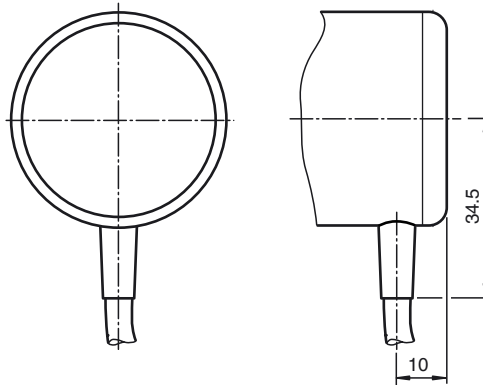

Output, radial, IP54

Electrical connection

Signal	Wire end	Connector
GND (encoder)	White	1
U _b (encoder)	Brown	2
Clock (+)	Green	3
Clock (-)	Yellow	4
Data (+)	Grey	5
Data (-)	Pink	6
Preset	Black or Blue	7
Counting direction	Red	8
Shielding	Shielding	Housing
Pinout	-	

Release date: 2015-01-09 15:14 Date of issue: 2016-01-26 t168924_eng.xml

Description

The Synchronous Serial Interface was specially developed for transferring the output data of an absolute encoder to a control device. The control module sends a clock bundle and the absolute encoder responds with the position value. Thus only 4 lines are required for the clock and data, no matter what the resolution of the rotary encoder is. The RS 422 interface is optically isolated from the power supply.

SSI signal course Standard

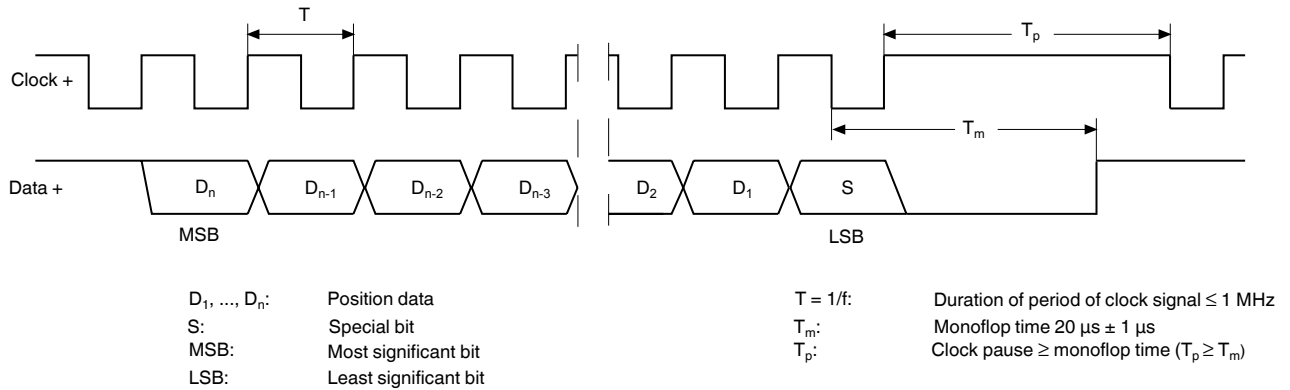

SSI output format Standard

- At idle status signal lines "Data +" and "Clock +" are at high level (5 V).
- The first time the clock signal switches from high to low, the data transfer in which the current information (position data (D_n) and special bit (S)) is stored in the encoder is introduced.
- The highest order bit (MSB) is applied to the serial data output of the encoder with the first rising pulse edge.
- The next successive lower order bit is transferred with each following rising pulse edge.
- After the lowest order bit (LSB) has been transferred the data line switches to low until the monoflop time T_m has expired.
- No subsequent data transfer can be started until the data line switches to high again or the time for the clock pause T_p has expired.
- After the clock sequence is complete, the monoflop time T_m is triggered with the last falling pulse edge.
- The monoflop time T_m determines the lowest transmission frequency.

SSI output format ring slide operation (multiple transmission)

- In ring slide operation, multiple transmission of the same data word over the SSI interface makes it possible to offer the possibility of detecting transmission errors.
- In multiple transmission, n bits are transferred per data word in standard format. The value n equals the total resolution of the encoder. As an example: a multturn encoder with a resolution of 8192 steps/revolution (13 bit) and a max. number of 4096 revolutions (12 bit) has a total resolution of $n = 25$ bit.
- If the clock change is not interrupted after the last falling pulse edge, ring slide operation automatically becomes active. This means that the information that was stored at the time of the first clock change is generated again.
- After the first position transmission, the n+1 pulse controls data repetition. If the n+1 pulse follows after an amount of time greater than the monoflop time T_m , a new current data word will be transmitted with the following pulses.



If the pulse line is exchanged, the data word is generated offset.

Block diagram

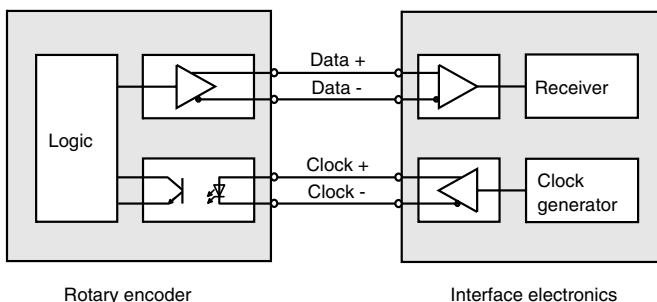

Line length

Line length in m	Baudrate in kHz
< 50	< 400
< 100	< 300
< 200	< 200
< 400	< 100

Release date: 2015-01-09 15:14 Date of issue: 2016-01-26 t166924_eng.xml

