

AVR-USB-STK development board

Users Manual



Pb-free, Green All boards produced by Olimex are ROHS compliant

Rev.A, July 2008

Copyright(c) 2008, OLIMEX Ltd, All rights reserved

INTRODUCTION:

AVR-USB-STK is easy to use development board for the new AT90USB162 microcontroller. With AT90USB162 is very easy to develop USB functionality to your next device, as Atmel provide free open source HID (mouse, keyboard) and CDC (USB-to-RS232) code and on top of this AT90USB162 cost is same as ATmega16, so what you are waiting for? **AVR-USB-STK** board allow all USB features of AT90USB162 to be explored. The board have USB connector, Joystick, RS232, SD-MMC card, Audio output, ICSP connector and extension connector. All AT90USB162 come from Atmel pre-programmed with bootloader which allow code to be programmed inside the chip without any external programmer, just download the FLIP software from Atmel web site and load your HEX code inside AT90USB162. To enter the bootloader mode you should press and hold HWB button, then press and release RST button. If you prefer to use ICSP programmer note that only AVR-DRAGON and AVR-ISP-MK2 is supporting AT90USB162 as these are pretty new devices, probably AVR Dude will add support later, but for the moment you can't use AVR-PG1 or AVR-PG2 for ICSP programming, another bad news is that AT90USB162 supports only debug Wire not JTAG so to debug it you should have the expensive AT-JTAGICE-MK2 or AVR-DRAGON.

BOARD FEATURES:

- AT90USB162 microcontroller with 16KB Flash, 512B RAM, 512B EEPROM
- ICSP 5x2 pin connector for in-circuit programming with AVR-ISP-MK2 (you generally don't need to use ICSP as you can program via USB)
- Debug Wire could be performed by 3 wires connected to ICSP (AT-JTAGICE-MK2 have such lose wire connector which to be used, you need VCC, GND, RST signals only)
- USB 2.0 Full speed connector
- RS232 driver and connector
- SD-MMC card connector
- Audio out 3.5 mm jack connector
- Extension connector with AVR port signals
- Status LED
- Joystick
- User button HWB (can be used to enter bootloader mode after reset)
- Reset button RST
- Takes power from USB no need for external adapter
- External power supply and voltage regulator if USB can't provide enough power
- Quartz crystal oscillator circuit 8Mhz
- Extension pin headers for each uC pin
- Four mounting holes 3.3 mm (0.13")
- Grid 100 mils
- GND bus
- Vcc bus
- FR-4, 1.5 mm (0,062"), green soldermask, white silkscreen component print
- Dimensions 77x72 mm (3x2.8")

ELECTROSTATIC WARNING:

The AVR-USB-STK board is shipped in protective anti-static packaging. The board must not be subject to high electrostatic potentials. General practice for working with static sensitive devices should be applied when working with this board.

BOARD USE REQUIREMENTS:

Cables: 1.8 meter USB A-B cable. RS232 female/male DB9 cable for connecting to PC RS232 port

Hardware: **AVR-DRAGON, AVR-JTAGICEMK2** or compatible tools

Software: AVR Studio + WinAVR free development IDE and C compiler

PROCESSOR FEATURES:

AVR-USB-STK uses Atmel 8-bit AVR CPU **AT90USB162** with these features:

- High Performance, Low Power AVR® 8-Bit Microcontroller
- Advanced RISC Architecture
- 125 Powerful Instructions – Most Single Clock Cycle Execution
- 32 x 8 General Purpose Working Registers
- Fully Static Operation
- Up to 16 MIPS Throughput at 16 MHz
- Non-volatile Program and Data Memories
- 8K / 16K Bytes of In-System Self-Programmable Flash
- Endurance: 10,000 Write/Erase Cycles
- Optional Boot Code Section with Independent Lock Bits
- USB boot-loader programmed by default in the factory
- In-System Programming by on-chip Boot Program hardware-activated after reset
- True Read-While-Write Operation
- 512 Bytes EEPROM
- Endurance: 100,000 Write/Erase Cycles
- 512 Bytes Internal SRAM
- Programming Lock for Software Security
- USB 2.0 Full-speed Device Module with Interrupt on Transfer Completion
- Complies fully with Universal Serial Bus Specification REV 2.0
- 48 MHz PLL for Full-speed Bus Operation : data transfer rates at 12 Mbit/s
- Fully independent 176 bytes USB DPRAM for endpoint memory allocation
- Endpoint 0 for Control Transfers: from 8 up to 64-bytes
- 4 Programmable Endpoints:
- IN or Out Directions
- Bulk, Interrupt and Isochronous Transfers
- Programmable maximum packet size from 8 to 64 bytes
- Programmable single or double buffer
- Suspend/Resume Interrupts
- Microcontroller reset on USB Bus Reset without detach
- USB Bus Disconnection on Microcontroller Request
- USB pad multiplexed with PS/2 peripheral for single cable capability
- PS/2 compliant pad
- One 8-bit Timer/Counters with Separate Prescaler and Compare Mode (two 8-bit PWM channels)

- One 16-bit Timer/Counter with Separate Prescaler, Compare and Capture Mode (three 8-bit PWM channels)
- USART with SPI master only mode and hardware flow control (RTS/CTS)
- Master/Slave SPI Serial Interface
- Programmable Watchdog Timer with Separate On-chip Oscillator
- On-chip Analog Comparator
- Interrupt and Wake-up on Pin Change
- On Chip Debug Interface (debugWIRE)
- Power-On Reset and Programmable Brown-out Detection
- Internal Calibrated Oscillator
- External and Internal Interrupt Sources
- Five Sleep Modes: Idle, Power-save, Power-down, Standby, and Extended Standby
- Operating Voltages – 2.7V – 5.5V
- Operating temperature - Industrial (-40°C to +85°C)

BLOCK DIAGRAM:

AT90USB162 Block Diagram

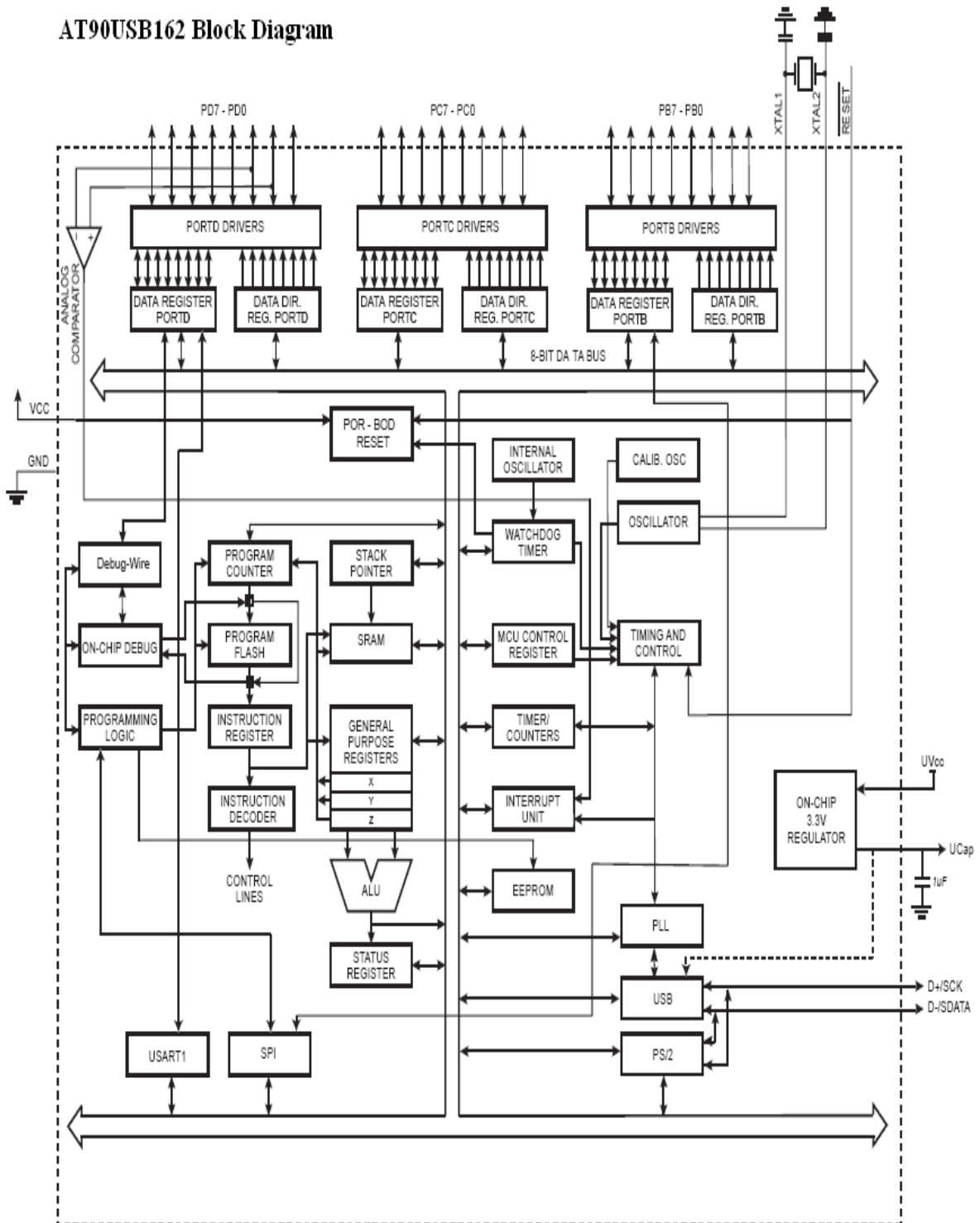

MEMORY MAP:

Figure 5-1. Program Memory Map

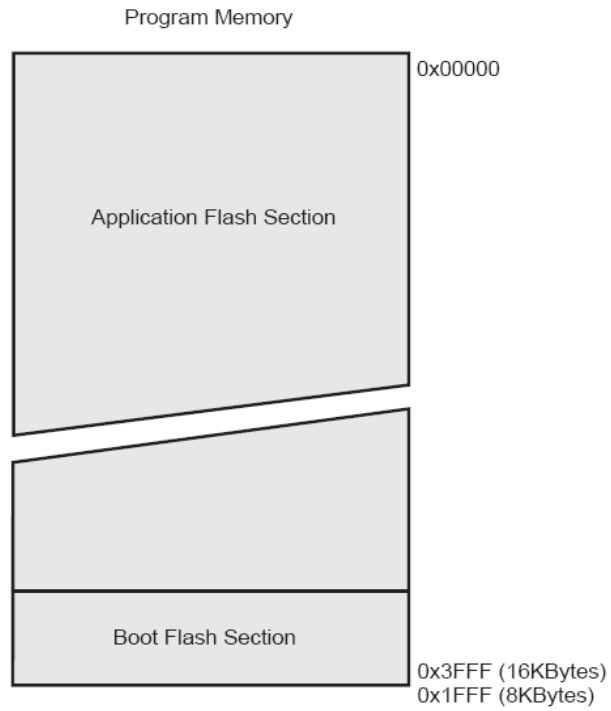

Data Memory Map

Data Memory	
32 Registers	\$0000 - \$001F
64 I/O Registers	\$0020 - \$005F
160 Ext I/O Reg.	\$0060 - \$00FF
	\$0100
Internal S RAM (512 x 8)	
	\$2FF

SCHEMATIC:

BOARD LAYOUT:

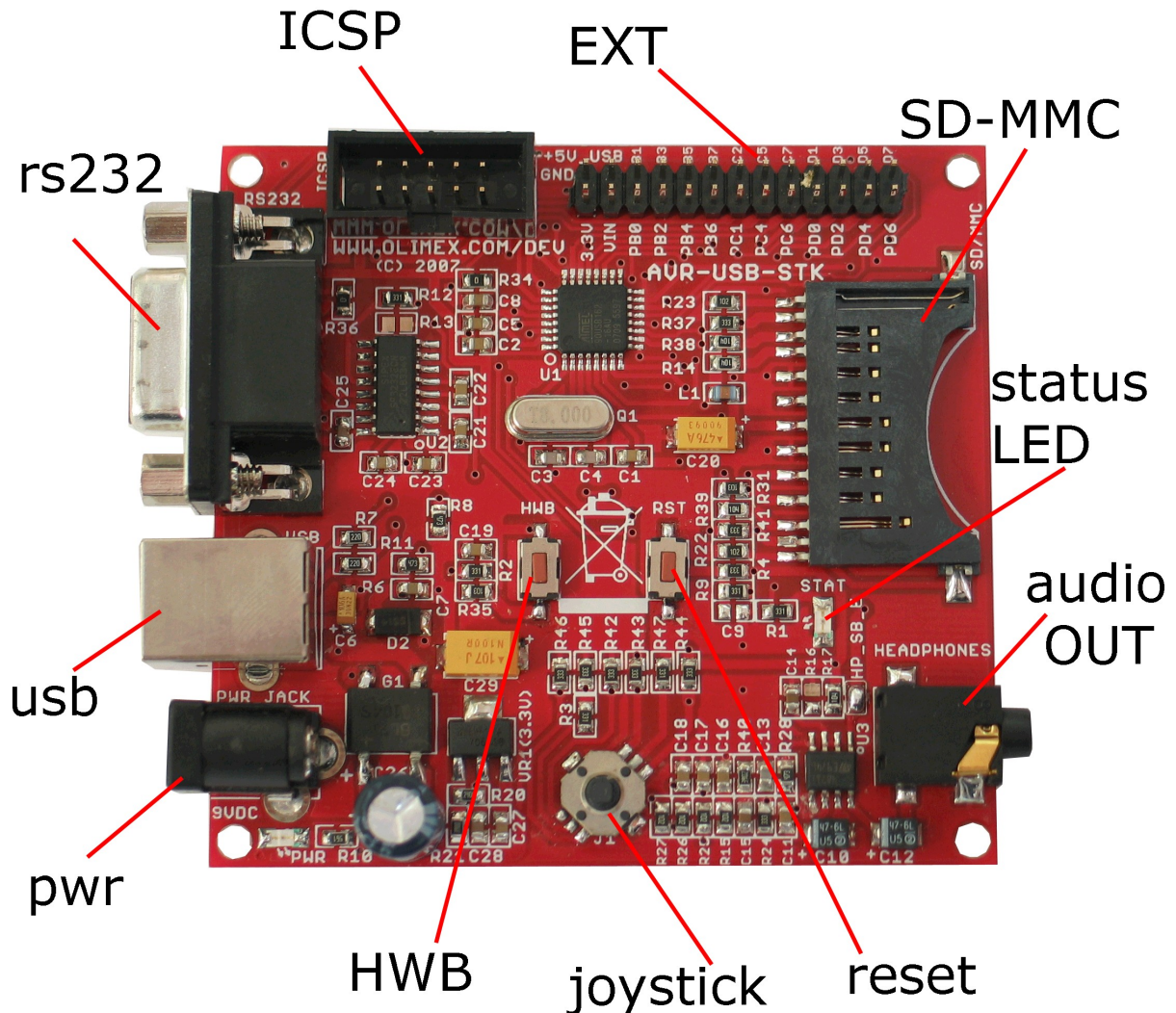

POWER SUPPLY CIRCUIT:

AVR-USB-STK can be powered from the USB port or from external power supply. The polarity of the external power supply doesn't matter as there is diode bridge at the front stage, this making possible AVR-USB-STK to be powered with AC or DC power adapters. The input voltage should be in the range of 7-12VDC or 6-9VAC. The board power consumption is about 15 mA.

RESET CIRCUIT:

AVR-USB-STK reset circuit consist of R4 pullup, RST button and R9 current limiting resistor. When RST button is pressed logical 0 is fed to the AT90USB162 reset input. As the reset port may be configured by the software as GPIO and output the current limiting resistor R9 is connected between the RST button and the microcontroller.

CLOCK CIRCUIT:

8MHz quartz crystal is connected to AT90USB162 pin 1 (XTAL1) and pin 2 ((PC0)/XTAL2). Internal PLL generates the 48Mhz necessary for the USB.

INPUT/OUTPUT:

Reset button with name **RST**.

Button with name **HWB**, connected to AT90USB162 pin 13 ((#CTS/#HWB/TD/INT7)/PD7) which, if pressed, could activate the USB Bootloader after reset or could be used as user button.

Joystick with name **JOYSTICK_MT5_F** with four used positions (up, down, right, left).

Power LED (red) with name **PWR**.

User status LED (red) with name **STAT**.

JUMPER DESCRIPTION:

the  **HP_SB_E**

When the jumper is closed, it enables AT90USB162 to control standby function of the audio amplifier U3 (TS4871). When the jumper is open, U3 enter standby mode.
Default state is closed.

CONNECTOR DESCRIPTIONS:

ICSP:

Pin #	Signal Name	Pin #	Signal Name
1	MOSI	2	VCC (+3.3V)
3	NC	4	GND
5	RST	6	GND
7	SCLK	8	GND
9	MISO	10	GND

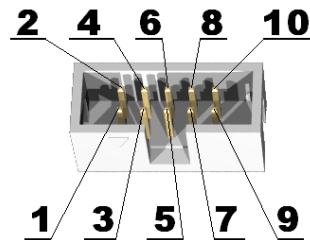

MOSI I/O **Master Out Slave In.** SPI data transfer signal. It is either input or output depending on whether the MCU is master or slave.

SCLK I/O **Serial (Synchronization) Clock.** This is the synchronization signal. It could be either input (MCU – slave) or output (MCU – master).

MISO I/O **Master In Slave Out.** SPI data transfer signal. It is either input or output depending on whether the MCU is master or slave.

EXT:

Pin #	Signal Name	Pin #	Signal Name
3.3V		GND	
VIN	EXT_PWR	+5V_USB	+5V
PB0	B5(SELECT)	PB1	SCLK
PB2	MOSI	PB3	MISO
PB4	B1(LEFT)	PB5	B2(UP)
PB6	B3(RIGHT)	PB7	B4(DOWN)
PC1	RST	PC2	CS_SD/MMC
PC4	USB_P	PC5	PWM_OUT
PC6	STNBY	PC7	INT4/ICP1
PD0	(OC.OB/INT0)	PD1	CP
PD2	RXD1	PD3	TXD1
PD4	(INT5)	PD5	WP
PD6	#RTS	PD7	#CTS/PD7

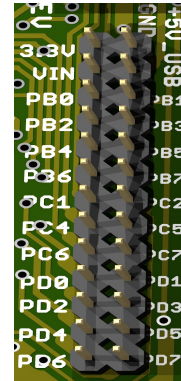

VIN Input **Voltage In.** You could apply external voltage at this pin.

MOSI I/O **Master Out Slave In.** SPI data transfer signal. It is either input or output depending on whether the MCU is master or slave.

MISO I/O **Master In Slave Out.** SPI data transfer signal. It is either input or output depending on whether the MCU is master or slave.

SCLK I/O **Serial (Synchronization) Clock.** This is the synchronization signal. It could be either input (MCU – slave) or output (MCU – master).

USB_P Input **USB Power.** The board could take power supply over the USB.

PWM_OUT Output **PWM Output.** This signal is passed to the headphones amplifier.

STNBY Output **Stand-by.** This signal controls the standby mode of the audio amplifier.

CP Input **Card Present.** This signal is part of the SD/MMC interface.

RXD1 Input **Receive Data.** This is the asynchronous data input for the RS232 interface.

TXD1 Output **Transmit Data.** This is the asynchronous data output for the RS232 interface.

WP Input **Write Protection.** This signal is part of the SD/MMC interface.

#RTS Output **Request To Send.** This signal is part of the RS232 interface.

#CTS Input **Clear To Send.** This signal is part of the RS232 interface.

RS232

Pin #	Signal Name	Pin #	Signal Name
1	NC	6	to pin 4
2	TXDOUT	7	RS-CTS
3	RXDIN	8	RS-RTS
4	to pin 6	9	GND
5	GND		

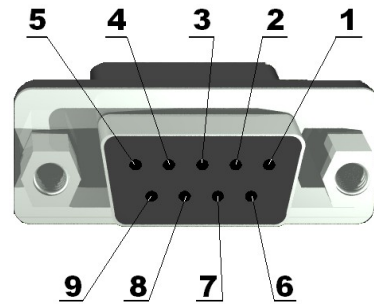

TXDOUT Output **Transmit Data**. This is the asynchronous data output for the RS232 interface.

RXDOUT Input **Receive Data**. This is the asynchronous data input for the RS232 interface.

#RTS Output **Request To Send**. This signal is part of the RS232 interface.

#CTS Input **Clear To Send**. This signal is part of the RS232 interface.

SD-MMC

Pin #	Signal Name	Pin #	Signal Name
1	CS_SD/MMC	9	Pull-up to 3.3V
2	MOSI	10	WP
3	GND	11	Not Connected
4	VDD	12	Not Connected
5	SCLK	13	CP
6	GND	14	Pull-down
7	MISO	15	Pull-down
8	Pull-up to 3.3V		

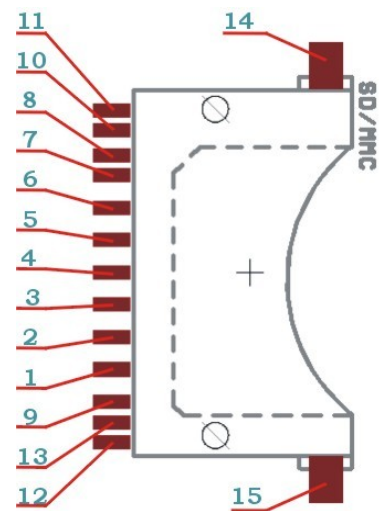

CS_SD/MMC Output **Chip Select SD/MMC**. This signal enables and disables the SD/MMC connector.

MOSI Output **Master Out Slave In**. As the access to the memory is via SPI interface, this is data output from the MCU (which is master) and input for the memory card (which is slave).

WP Input **Write Protection**. This signal is part of the SD/MMC interface.

SCLK Output **Serial (Synchronization) Clock**. This is the synchronization clock for the data transfer.

CP Input **Card Present**. This signal is part of the SD/MMC interface.

MISO Input **Master In Slave Out**. As the access to the memory card is via SPI interface, this is data input for the MCU (which is master) and data output from the memory card (which is slave).

USB

Pin #	Signal Name
1	+5V
2	D-
3	D+
4	GND

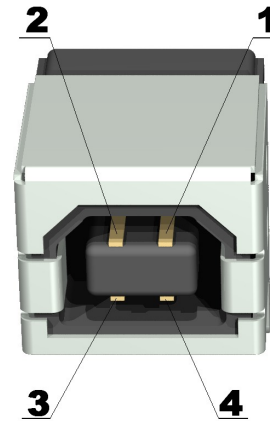

D- and D+ both form differential input or output depending on the direction of the data flow.

PWR JACK

Pin #	Signal Name
1	9VDC/6VAC
2	GND

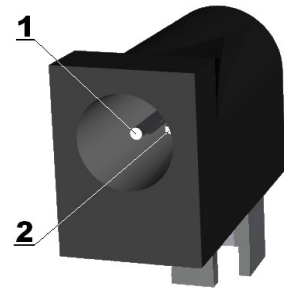

Audio Out:

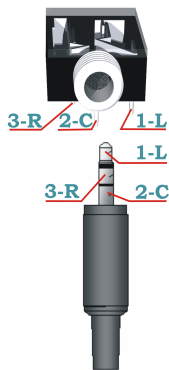

MECHANICAL DIMENSIONS:

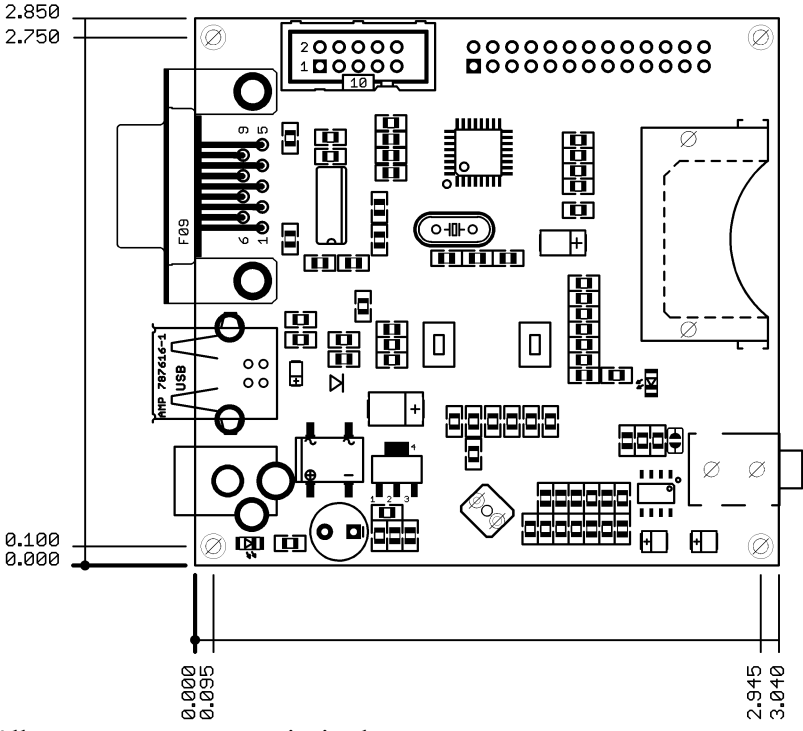

All measurements are in inches.

ORDER CODE:

AVR-USB-STK - assembled and tested (no kit, no soldering required)

How to order?

You can order to us directly or by any of our distributors.

Check our web www.olimex.com/dev for more info.

Revision history:

REV.A - created July 2008

Disclaimer:

© 2008 Olimex Ltd. All rights reserved. Olimex®, logo and combinations thereof, are registered trademarks of Olimex Ltd. Other terms and product names may be trademarks of others.

The information in this document is provided in connection with Olimex products. No license, express or implied or otherwise, to any intellectual property right is granted by this document or in connection with the sale of Olimex products.

Neither the whole nor any part of the information contained in or the product described in this document may be adapted or reproduced in any material form except with the prior written permission of the copyright holder.

The product described in this document is subject to continuous development and improvements. All particulars of the product and its use contained in this document are given by OLIMEX in good faith. However all warranties implied or expressed including but not limited to implied warranties of merchantability or fitness for purpose are excluded. This document is intended only to assist the reader in the use of the product. OLIMEX Ltd. shall not be liable for any loss or damage arising from the use of any information in this document or any error or omission in such information or any incorrect use of the product.